

More About — 150-WATT SINGLE BANDERS

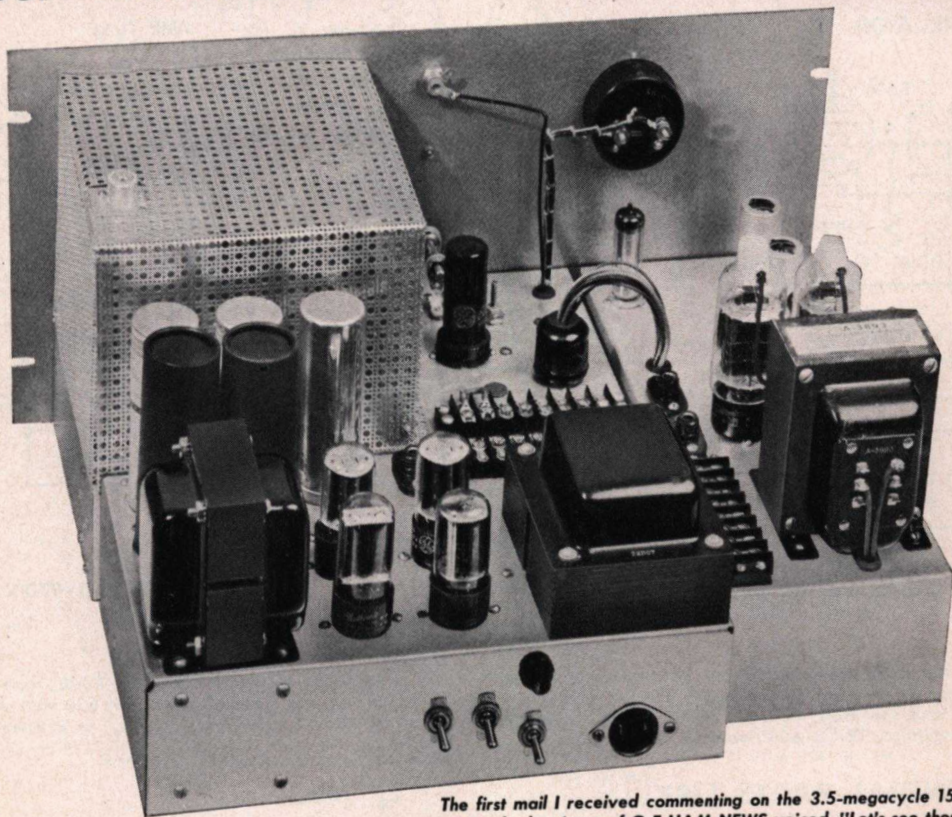

7- AND 14-MEGACYCLE TRANSMITTERS

The first mail I received commenting on the 3.5-megacycle 150-watt transmitter in the last issue of G-E HAM NEWS voiced, "Let's see those rigs for the other bands, Larry." So I'm glad to oblige with circuit and construction details for the 7 and 14-megacycle models, plus suggestions for preventing interference to television reception, in this issue. The modulator-keyer unit shown above is undergoing tests and will be described in a subsequent issue.

—Lighthouse Larry

CONTENTS

MORE ABOUT 150-WATT SINGLE BANDERS.....	page 2
Sweeping the Spectrum.....	page 7
Single Bander Random Ideas.....	page 8

MORE ABOUT 150-WATT SINGLE BANDERS

The main features in the RF chassis of the 3.5-megacycle transmitter model—simple two-stage circuit, extra high-C oscillator and automatic VFO switch—have attracted a great deal of attention. The hundreds of radio amateurs who have personally inspected the transmitter models, and comments received in letters, all seem to agree that this is an ideal transmitter for CW operation on a favorite band.

In addition, many fellows have requested information on, or suggested changes; these fall mainly into the following statements:

1. "What is the easiest way to provide for both VFO and crystal control of the oscillator circuit?"

2. "How should the oscillator be wired for crystal control only for novices?"
3. "Do you have a circuit for a bandswitching model of this transmitter covering 3.5 to 30 megacycles, or at least two or three bands?"
4. "Can you suggest the best way to build a band-switching VFO using the extra high-C circuit?"
5. "What changes are necessary to convert the transmitters to double sideband operation?"

Some of these questions will be answered in the description of the 7 and 14-megacycle transmitters that follows. The remaining suggestions will be commented upon at the conclusion of this article.

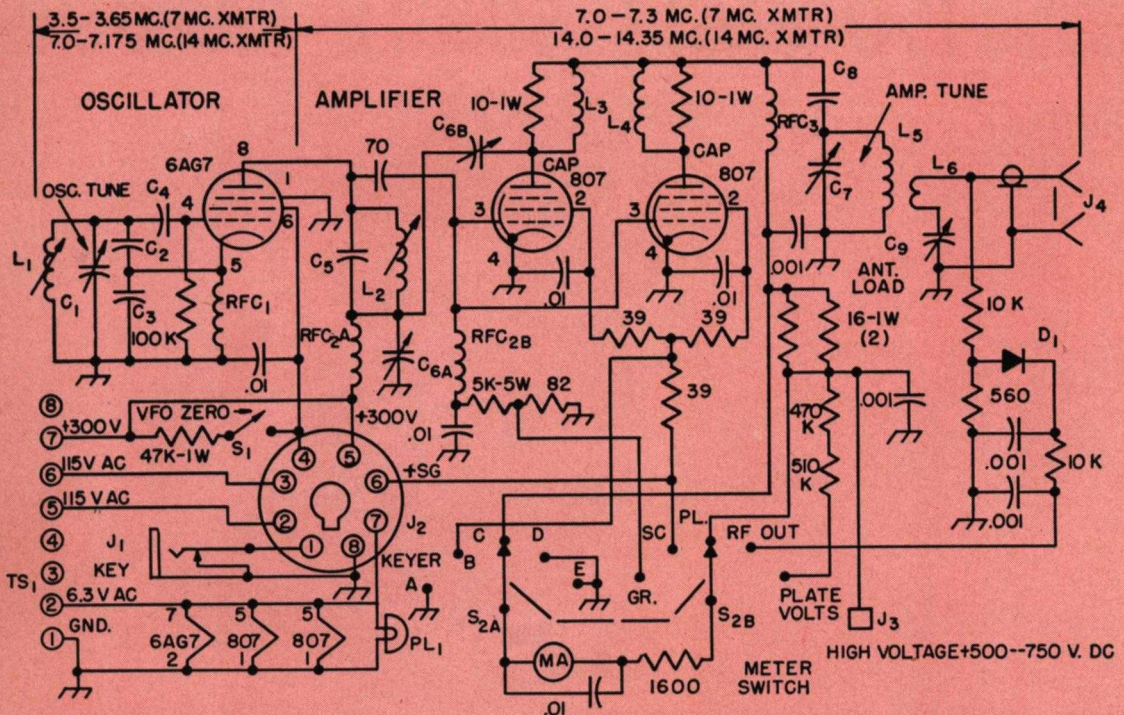

Fig. 1. Schematic diagram of the 7 and 14-megacycle transmitters. All resistor values are in ohms (K=1000), one-half watt unless otherwise specified. Capacitances given in whole numbers are in mmf; those in decimals are in mf; 600 volts working unless otherwise specified. Metering switch (S₂) positions are: "A," 0-25 ma DC; "B," 0-50 ma DC; "C," 0-250 ma DC; "D," RF output voltage; "E," 0-1000 volts DC.

GENERAL PARTS LIST

- C₄—100-mmf silvered mica
- C₈—0.001-mfd, 2500-volt working mica
- D₁—general purpose germanium diode (G-E 1N48)
- J₁—closed circuit phone jack
- J₂—octal tube socket
- J₃—high-voltage connector (Millen 37001)
- J₄—chassis coaxial connector
- L₃, L₄—6 turns, No. 16 enameled wire closewound on a 1/4-inch-diameter, 1-watt resistor
- MA—0-1-milliammeter (G-E DW-71 or equivalent)
- PL₁—panel lamp bracket (Johnson 147-330)
- S₁—single-pole, single-throw, normally open push-button switch (Switchcraft No. 101 or equivalent)
- S₂—2-pole, 5-position, non-shorting ceramic tap switch (Centralab No. 2505)
- TS₁—8-terminal barrier type terminal strip

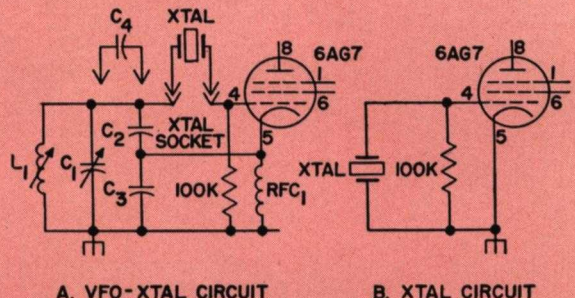

Fig. 2. Schematic diagrams showing: A—method for including a crystal socket in the oscillator grid circuit into which either C₄ or a crystal ground for half the amplifier output frequency may be plugged; and B—schematic diagram for a crystal oscillator, with crystal ground for output frequency.

CIRCUIT DETAILS—7 AND 14-MEGACYCLE TRANSMITTERS

The same tube lineup used in the 3.5-megacycle transmitter, 6AG7 oscillator, and two 807's in the amplifier, was found equally suitable for the 7 and 14-megacycle transmitters. Comparison of the schematic diagram for the latter units, as shown in Fig. 1, with that in the November-December, 1957 issue, will indicate some differences. In all three transmitters, the oscillator grid circuit operates at half the amplifier output frequency.

The frequency determining circuitry is identical to that in the 3.5-megacycle transmitter, but variable capacitors having a smaller capacitance range are used for C₁, the oscillator tuning. Since the 7 and 14-megacycle amateur bands are quite narrow, percentage-wise,

it was possible to employ a single parallel-tuned tank circuit, C₅-L₂, and capacitive interstage coupling between the oscillator plate and amplifier grid circuits. The oscillator plate circuit operates as a frequency doubler, being tuned to the same band as the amplifier plate circuit.

Sufficient regeneration occurred in the 807 amplifier stage to cause oscillation under certain conditions in the 14-megacycle transmitter with no grid driving power, full screen voltage and class A bias applied to the 807's. So, a neutralizing circuit was added to both transmitters with capacitor C_{6B} forming one leg of a bridge neutralizing circuit that balances the combined grid-to-plate capacitance in the 807 tubes. The tube plates compose one plate of this capacitor, the other plate

PARTS LIST—3.5-, 7- AND 14-MEGACYCLE TRANSMITTERS

PART NO.	BAND MC	COMPONENT	VALUE	RATING
C ₁	3.5 7 14	capacitor, air variable	15-325 mmf 10-150 mmf 6-50 mmf	0.024-inch air gap
C ₂ , C ₃	3.5 7 14	capacitor, silvered mica	0.005 mfd 0.004 mfd 0.002 mfd	500 volts working
C ₅ , C ₆	3.5 7 14	capacitor	200 mmf 100 mmf 700 mmf	500 volts working
C _{6A}	7 & 14	capacitor, mica padder variable	100-500 mmf	500 volts working
C _{6B}	7 & 14	capacitor, neutralizing	see "MECHANICAL DETAILS"	
C ₇	3.5 7 14	capacitor, air variable	15-350 mmf 10-150 mmf 8-75 mmf	0.45-0.060-inch air gap
C ₉	3.5 & 7 14	capacitor, 2 gang air variable 1 gang	20-700 mmf 10-350 mmf	0.015-0.020-inch air gap
L ₁	3.5 7 14	inductance, iron slug tuned	2.1 uh, 14 turns, No. 20 wire 11/16 in. long 1.0 uh, 10 turns, No. 18 wire 11/16 in. long 0.5 uh, 7 turns, No. 18 wire 11/16 in. long	wound on National XR-50 coil form
L _{2A} , L _{2B}	3.5	inductance, iron slug tuned	8.5 uh, 28 turns, No. 24 wire 11/16 in. long	wound on National XR-50 coil form
L ₂	7 14	inductance, iron slug tuned	4.2 uh, 20 turns, No. 20 wire 11/16 in. long 2.1 uh, 14 turns, No. 20 wire 11/16 in. long	wound on National XR-50 coil form
L ₅	3.5 7 14	inductance, air-wound, plastic strip insulation	6.8 uh, 20 turns, No. 16 wire 1 1/2 in. dia., 2 1/2 in. long 3.4 uh, 15 turns, No. 16 wire 1 1/2 in. dia., 2 1/2 in. long 1.7 uh, 12 turns, No. 14 wire 1 1/2 in. dia., 3 in. long	(air-dux No. 1208) (air-dux No. 1206) (air-dux No. 1204)
L ₆	3.5 7 14	inductance, wound over grounded end of L ₅	5 turns, HV insulated wire 3 turns, HV insulated wire 3 turns, HV insulated wire	
RFC ₁	3.5 7 & 14	RF choke, small 3 pi	1.0 mh, 75 ma. 0.5 mh, 75 ma.	National R-50
RFC ₂ , RFC _{2A} RFC _{2B}	3.5, 7 & 14	RF choke, small 3 pi	0.5 mh, 75 ma.	National R-50
RFC ₃	3.5 7 14	RF choke, medium 3 pi RF choke, medium 3 pi or scramble wound solenoid type RF choke, single layer solenoid or home-wound RF choke	1.0 mh, 300 ma. 0.5 mh, 300 ma. 200 uh, 500 ma. 30 uh, 500 ma. 28 uh, 110 turns, No. 28 enameled wire, 2 1/2 in. long, turns spaced dia. of wire	National R-300U Raypar RL-112 Raypar RL-111 wound on 1/2 in. dia. plastic rod

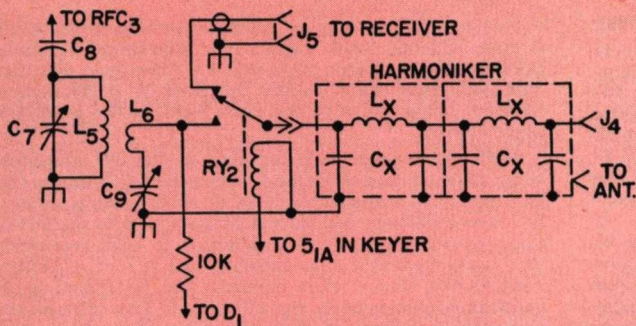

Fig. 3. Schematic diagram showing a built-in antenna switching relay and Harmoniker type TVI filter, both of which can be included on the transmitter chassis.

PARTS LIST—ANTENNA RELAY—HARMONIKER

3.5 MEGACYCLES

L_x —840 mmf, 500-volt mica
 L_s —2.1 uh, 12 turns, No. 18 wire, 1 inch in diameter, 1 1/2 inches long (Miniconductor No. 3014, or air-dux No. 808)

7 MEGACYCLES

C_x —430 mmf, 500-volt mica
 L_x —1.1 uh, 13 turns, No. 18 wire, 5/8 of an inch in diameter, 1 3/8 inches long (Miniductor No. 3006, or air-dux No. 508)

14 MEGACYCLES

C_x —220 mmf, 500-volt mica
 L_x —0.55 uh, 10 turns, No. 18 wire, 1/2 inch in diameter, 1 1/4 inches long (Miniconductor No. 3002, or air-dux No. 408)

J_5 —chassis coaxial cable connector, or female chassis phono jack

RY_2 —single pole (or double pole—see text), double throw midget relay, RF type, 6 or 115-volt AC coil (Potter and Brumfield KT-11A, or Advance AM/2C)

being a small aluminum plate that projects up between the tubes. A 100–500-mmf mica padder variable capacitor at C_{0A} provides a convenient adjustment to achieve complete neutralization.

The simplest method of adapting the oscillator circuit for both VFO and crystal controlled operation is to remove C_4 from the circuit and substitute a crystal instead, as shown in Fig. 2A. In one transmitter, the crystal socket was mounted on the chassis directly behind L_1 . Pins from an octal tube base were then soldered onto the leads on C_4 , so that it could be plugged into the crystal socket whenever VFO operation was desired. The crystals should be ground for half the amplifier output frequency.

The oscillator can be wired for only crystal controlled operation by eliminating C_1 , C_2 , C_3 , C_4 , L_1 , and RFC_1 . The resulting circuit is shown in Fig. 2B. Crystals used with this circuit should be ground for the output frequency. Harmonic type crystal oscillator circuits for the 6AG7 can be found in the "High Frequency Transmitters" chapter of the *Radio Amateur's Handbook*.

The power, metering and RF output coupling circuitry is essentially similar to corresponding circuits in

the 3.5-megacycle transmitter in the November–December, 1957 issue. If desired, an antenna switching relay and half-wave "Harmoniker" type bandpass filter can be incorporated into the transmitter chassis. This was done on the 14-megacycle transmitter model instead of placing these items in an unused corner of the table relay rack cabinet. Although a single-pole, double-throw relay, RY_2 , is shown in the suggested circuit of Fig. 3, a double-pole, double-throw relay can be substituted. The extra set of contacts will come in handy to ground the antenna connection to the receiver when the relay is energized.

MECHANICAL DETAILS

The photo on page 1 of this issue shows how the three portions of the complete transmitter—RF unit, dual-voltage power supply and a combination keyer-modulator unit—will look when they are placed inside a table relay rack cabinet. Unitized construction simplifies the task of making changes or rebuilding any of these units later on.

Both the 7 and 14-megacycle transmitters were constructed on 7 x 12 x 3-inch aluminum chassis (Bud

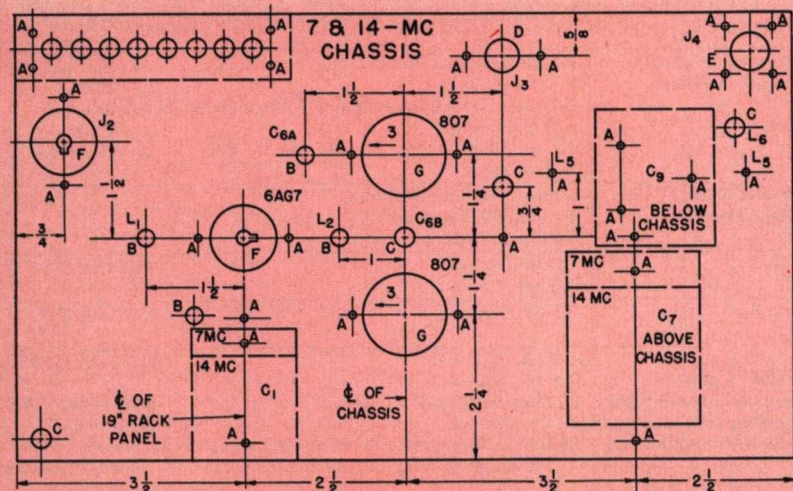

DRILLING LEGEND

- "A" drill—No. 26 for tube socket bolts, etc.
- "B" drill—5/32 of an inch diameter for small coil forms.
- "C" drill—3/8 of an inch in diameter.
- "D" drill—1/2 of an inch in diameter.
- "E" drill—3/8 of an inch in diameter.
- "F" socket punch—1 1/16 inches in diameter for octal tube sockets.
- "G" socket punch—1 1/4 inches in diameter for GL-807 tube sockets.

Fig. 4. Chassis deck drilling diagram for the 7 and 14-megacycle transmitters. Small holes should be located from corresponding holes on the components.

AC-408). The parts layout is quite similar to that used for the 3.5-megacycle transmitter. Changes shown in the drilling diagram, Fig. 4, include moving the oscillator tube closer to the panel and different drilling for the interstage coupling and neutralizing components.

Two locations were tried for the 807 amplifier circuit coil, L_5 , with no apparent difference in performance. In the 7-megacycle transmitter, L_5 was fastened to the chassis deck behind C_7 with 1-inch high ceramic pillar insulators, as shown in the top view, Fig. 5. This location for L_5 was not practical in the 3.5-megacycle transmitter, where C_7 was over an inch longer. Since C_7 in the 14-megacycle transmitter was considerably shorter than L_5 , a 2½-inch long ceramic pillar insulator supported the "hot" end of L_5 directly from the chassis.

The neutralizing capacitor, C_{6B} , was formed by bending a ½-inch wide lip, drilled at the middle, on one end of a ¾ x 3-inch strip of ⅛-inch thick soft aluminum sheet. This strip was then mounted between the 807's on a ⅝-inch-high feedthrough insulator. The small components are mounted under the chassis either on the tube socket lugs or small terminal lug strips, as shown in Fig. 6. The exact placement of these parts is not critical provided that the RF and bypass circuit leads are made as short as possible. Each transmitter in this series was wired somewhat differently in order to check on lead dress.

Additional harmonic suppression features were tried on the 14-megacycle transmitter; these included shielding the 807 amplifier, placing 0.01-mfd bypass capacitors on all terminals running out of the transmitter chassis, and mounting the *Harmoniker* output filter directly on the chassis.

A shield box, 6¾ inches wide, 7 inches deep, and 5 inches high was fashioned from perforated aluminum sheet. This shield is shown in the cover photo. One-half inch wide lips were extended down over the side, rear and chassis deck. The front of the shield was fastened to lips bent onto a second piece of perforated aluminum sheet fastened behind the panel. A metal chassis bottom plate was also added.

The *Harmoniker* was constructed in a 2¼ x 2¼ x 5-inch Minibox (Bud CU-3004) which also supports the amplifier shield. Holes which match the location of J_4 on the chassis diagram were punched in both ends of the Minibox, as shown in the detail view of the 14-megacycle amplifier, Fig. 7 (left). Note that another piece of perforated aluminum sheet serves as a shield between the coils, L_x , in the *Harmoniker*. Capacitors C_x were soldered between the ends of the coils and grounding lugs fastened to the side of the box. The lead running through the shield was insulated with a small plastic sleeve.

The antenna switching relay, RY_2 in Fig. 3, was fastened beneath the chassis next to C_9 . The short lead from the relay arm to the *Harmoniker* may be brought up through the hole in the chassis, as shown, or through a small ceramic feedthrough insulator.

Since a parallel-feed system was used to apply plate voltage to the 807 stage, some care must be exercised in choosing an RF choke for RFC_3 . In the 14-megacycle transmitter, a solenoid type single layer wound RF choke was found to work best. In Fig. 8 (left), a commercially made choke (Raypar RL-112) is shown mounted upon a 500-mmf high-voltage ceramic capacitor from a television receiver.

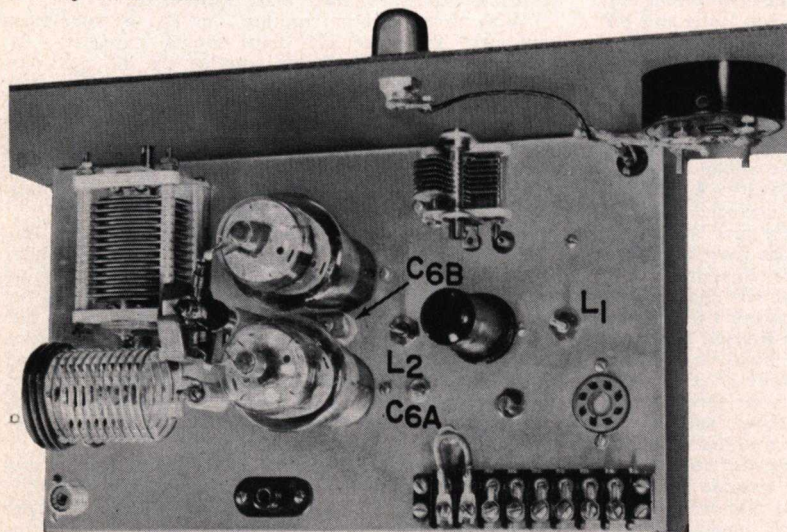

Fig. 5. Top view of the 7-megacycle transmitter chassis. Note the ceramic feedthrough insulator between the 807's on which the neutralizing capacitor plate, C_{6B} , is mounted.

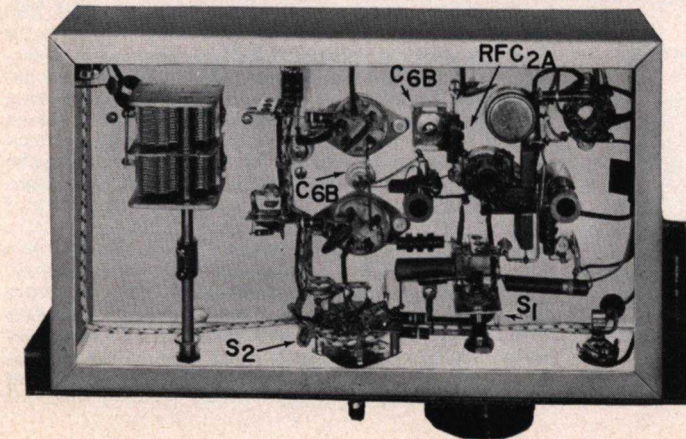

Fig. 6. Bottom view of the 7-megacycle transmitter chassis. All power and metering circuit wiring is placed close to the chassis wherever practical. The potentiometer shown next to the 6AG7 tube socket was used in oscillator screen voltage experiments on this model.

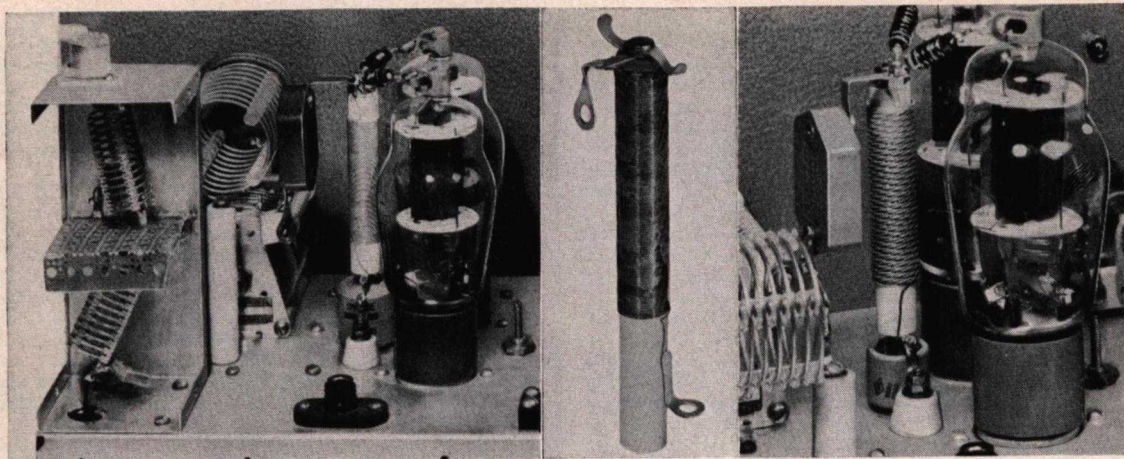

Fig. 7. Detail views of the RF chokes used for RFC₃ in the 7 and 14-megacycle transmitters. (Left) The 14-megacycle 807 amplifier stage with a Raypar RL-112 RF choke mounted atop a 500-mmf television receiver high-voltage ceramic capacitor. In this transmitter, the 807 plate circuit coil, L₅, was mounted on the tuning capacitor, C₇. This change left room on the chassis rear corner for the 14-megacycle unbalanced type *Harmoniker*. (Center) The home wound RF choke which also is suitable for RFC₃ in the 14-megacycle transmitter. (Right) The 7-megacycle amplifier stage showing the Raypar RL-102 RF choke mounted on a Centralab type 858S-1000 0.001-mfd cylindrical type ceramic capacitor.

A suitable home made RF choke for this transmitter may be wound on a 1/2-inch-diameter polystyrene rod, also shown in Fig. 7 (center). Both ends of the rod are threaded for 6-32 machine screws. Three soldering lugs at the upper end hold the 807 plate cap leads and RF choke wire. This wire was secured at the lower end of the winding by threading it through a small hole in the plastic rod.

Cut the polystyrene rod 3 inches long if the home made choke is to be mounted upon a ceramic capacitor, as was done with the Raypar choke. The rod shown was cut 4 1/2 inches long so that the choke could be fastened directly to the chassis. Substitute a 0.001-mfd, 2000-volt disc ceramic capacitor, connected between the high-voltage feedthrough insulator just behind the choke and a soldering lug between the plastic rod and the chassis, for the cylindrical bypass capacitor.

Two types of commercially wound RF chokes were found suitable for RFC₃ in the 7-megacycle transmitter. In the detail view of Fig. 7 (right), a Raypar type RL-102 RF choke was mounted on a small 0.001-mfd, 5000-volt cylindrical ceramic capacitor (Centralab type 858S-1000) having tapped holes for terminals. A conventional 0.5-mh pi-wound RF choke, such as the National R-300U, also permitted normal performance. This type of choke, having a threaded stud on one end, was mounted on a 1/2-inch-diameter ceramic pillar insulator 2 1/2 inches high. A 0.001-mfd disc ceramic bypass capacitor was placed beneath the chassis adjacent to the high-voltage feedthrough insulator.

OPERATION—7 AND 14-MEGACYCLE TRANSMITTERS

The initial tune-up procedure for the 7 and 14-megacycle transmitters follows that described in the last issue for the 3.5-megacycle transmitter. First, the oscillator is checked for proper operation and adjusted for the desired frequency coverage by setting the slug in L₁. For CW operation, adjust L₁ so that the oscillator is a few kilocycles inside the low-frequency ends of the respective bands with C₁ set at maximum capacity. Then, when C₁ is rotated from maximum to minimum capacity, the 7-megacycle transmitter should cover approximately 7.0-7.2 megacycles; the 14-megacycle transmitter should tune 14.0-14.25 megacycles, both with the capacity values listed for C₁ in the PARTS LIST.

The interstage coupling coil, L₂, should be tuned for maximum grid current in meter position "A" with C₁

set in the center of the tuning range. It is best to not apply screen and plate voltage to the 807 amplifier until the above adjustments, and the following neutralizing procedure, have been completed.

With the oscillator running, set C_{6A} at maximum capacity. Tune the 807 plate tuning capacitor, C₇, through its range and note whether the 807 grid current fluctuates. Some variation probably will be noted, indicating that the 807 amplifier is not neutralized. Slowly turn C_{6A} toward minimum capacity while rocking C₇ back and forth through the capacity setting at which the variation in grid current occurred. A setting of C_{6A} should be found at which practically no fluctuation in grid current can be noticed.

Plate and screen voltages (500-750 and 250-300, respectively) can now be applied to the 807 amplifier stage to test the transmitter with a dummy antenna before putting it on the air. A 100-watt lamp connected to J₁ makes a suitable dummy antenna load. With 600 plate volts on the 807's, all transmitters could be loaded up to 250 milliamperes plate current (meter position "C") by adjusting C₉ for maximum RF output voltage, as indicated in meter position "D." Normal screen current (position "B") on the 807 stage will be about 12-15 milliamperes at full plate current.

The link output coupling circuit shown in the main schematic diagram is suitable for loading the transmitter directly into half-wave dipole antennas fed either with 52 or 72-ohm coaxial cable; or with 72-ohm twinlead. "All-band" antennas fed with these cables also should load the transmitter to full output, usually with C₉ set at some point between half and maximum capacity. A suitable antenna coupler should be inserted between the transmitter and antenna feedlines having higher impedances, such as 300-ohm twinlead; or for an end-fed antenna. Most amateur radio and antenna handbooks describe circuits for properly matching the low-impedance transmitter output to these higher impedance antennas.

PARASITICS

There is an error in the schematic diagram for the Clapp circuit on page 6 of the November-December, 1957, issue of G-E HAM NEWS, Fig. 1A. The circuit as shown shorts out the RF choke in the tube cathode-to-ground lead. There should be no connection at the junction of the lead at the lower end of the grid resistor, and the lead running from the cathode to the 0.001-mfd capacitors from grid to ground.

SWEEPING *the* SPECTRUM



Wherever you find persons who have distinguished themselves in community and other public service activities, you are sure to find radio amateurs.

This has been proven time and time again in our annual Edison Radio Amateur Award program; it's equally true of the thirteen full-time electronics technicians who recently were recipients of the first annual All-American Awards for public service, sponsored by General Electric's Receiving Tube Department. All thirteen winners received trophies and checks for \$500, for use in a community activity of their preference, at a ceremony in Washington, D. C., last month.

Five of the thirteen technicians are FCC-licensed radio amateurs. Their names, call letters, and the public services for which they were honored, are as follows:

Frank J. Hatler, W2EUI, Roselle, N. J., cited for long and outstanding organizational efforts in civil defense and emergency communications by amateur radio and several instances of on-the-scene emergency service, including three aircraft crash disasters.

Mortimer Libowitz, K2BDQ, Brooklyn, N. Y., has trained many youngsters in the art and science of radionics, developing some into hams, and others into repairmen; also active in civil defense and Red Cross communications.

Richard G. Wells, Jr., W4NSZ, Pikeville, Ky., furnished free cable connections to a community television system to public schools and hospitals, aided in flood emergency and Civil Defense communications and encouraged youths in electronics.

Scott A. Witcher, Jr., W5YIS, Lampasas, Texas, saved the lives of many trapped persons during disastrous floods in May, then directed emergency communications through his amateur radio station.

Bart Rypstra, W8NWO, Charlotte, Mich., cited for outstanding community service with Boy Scouts, rendering free radio and television servicing for needy people, and assisting in civil defense communications with his amateur station.

Heartiest congratulations to these outstanding radio amateurs!



We've never seen such a reshuffling, rebuilding and rehashing of mobile amateur radio gear as has taken place ever since the automotive stylists systematically eliminated most of the roomy spaces behind and immediately below the dashboard in the newer cars. This is in addition, of course, to all the heater and power supply circuit rewiring brought about by the changeover from 6 to 12-volt automotive electrical systems.

Those smoothly sloping underdashes may cause some new owners to wax eloquently, but they all but frustrate the ham who is attempting to install his mobile receiver and transmitter snugly against the dash and still leave some footroom for the middle front seat passenger. And if the gear is mounted astride the transmission hump, the need for longer than normal arms, plus diverted attention that creates a safety hazard, is the price paid by the mobiler.

We've seen that much-desired "built-in look" in only one installation of mobile gear in a 1957 auto, in a make having a large removable panel in the center of the dash. But even the 1958 model of this vehicle has been altered to effectively render this space unavailable for mobile gear.

What will be the answer to this problem? The user of commercially built equipment may resign himself to installing his mobile station on the transmission hump. The home constructor can still hope for a less conspicuous installation by building his gear in some weird shape which will fit up behind the right corner of the dash, and bring out a remote tuning dial and other essential controls to an accessible location on the dash. Non-smoking mobileers might even consider discarding the dash ash tray, substituting these controls in its place!

Whatever the solution to your particular mobile gear installation problem, it is clear that you will have to call upon ingenuity never before utilized in order to be able to call, "CQ . . . CQ, this is W . . . /mobile . . ."



About a year ago in this column I mentioned that General Electric has produced a series of educational motion picture films on subjects related to electronics. These films all fit standard 16-millimeter sound projectors and run from ten to thirty minutes in length. Some are in black and white; others are in color.

These films are available for loan to amateur radio clubs, school classes, and any other groups, at no charge, from eighteen film libraries which G.E. maintains in large cities in the United States. In case your club secretary, group adviser, or program chairman has not received a copy of the catalog in which all current films are listed, he may do so by sending a postal card to me requesting it.

This catalog also lists the film library address in your area from which the films should be obtained. I'm sure you'll enjoy them as a club program.



We've been seeing—and hearing—more and more about a relative newcomer to the ranks of amateur radio periodicals—one that has been very well received in our western states—entitled *West Coast Ham Ads*.

Now rounding out its fourth year of publication, this forty-page monthly magazine usually contains really informative technical articles, news of West Coast ham activities and club meetings, information on new products and trends in the amateur equipment field, and, of course, a smattering of advertising. If we've whetted your appetite, a postal card to them at 10517 Haverly Street, El Monte, California, will bring further details to your shack.

—Lighthouse Larry

SINGLE BANDER RANDOM IDEAS

Some of the most numerous questions we have received regarding the 150-watt single band transmitters—those pertaining to inclusion of crystal controlled operation, and circuit data for 7 and 14-megacycle transmitters—have been answered elsewhere in this issue. Other questions—circuit data for 1.8 and 21-megacycle transmitters; bandswitching ideas for both the high-C VFO and complete transmitter; circuit changes for double sideband operation; and a mechanical arrangement whereby separate RF units for each band could be plugged into a cabinet containing a common power supply, keyer or modulator and metering circuits—will be commented upon here.

Generally, circuit constants for a 1.8-megacycle transmitter—capacitances and inductances of C_1 , C_2 , C_3 , C_5 , C_6 , C_7 , and C_9 , L_1 , L_{2B} , and L_5 —should be twice the values shown for the 3.5-megacycle transmitter. The value of C_9 and L_5 will depend upon the antenna feedline impedance into which the transmitter works.

Two methods of scaling down the data shown for the 14-megacycle transmitter for a 21-megacycle transmitter are practical. First, the oscillator grid circuit can be left on 7 megacycles, with the plate circuit tripling to 21 megacycles. For this, C_5 , C_7 , L_2 , L_5 and L_6 are reduced to two-thirds of their 14-megacycle counterparts. Or, the oscillator grid circuit can be placed on 10.5 megacycles, doubling in the plate circuit to 21 megacycles. This method requires that C_1 , C_2 , C_3 , and L_1 be scaled down to two-thirds of the 14-megacycle transmitter values.

Devising a ganged bandswitching system for this—or any—transmitter that does not assume the proportions of a mechanical monstrosity is quite a problem. We've tried several ideas, both on paper and on test models, but, as the old saying goes, "The issue is still in doubt." Contacts on the compact, inexpensive ceramic-insulated tap switches are not quite durable

enough for switching the 807 plate circuit unless caution is always exercised when changing bands—i.e., turning off the high voltage first. The heavy duty tap switches will withstand this abuse, but their cost approaches that of a rotary inductor.

Preliminary tests with double sideband circuitry in the 807 stage—incorporating a push-pull grid circuit and bringing out separate screen voltage connections for each 807—indicate that more isolation would be desirable between the oscillator and amplifier stages to eliminate any trace of frequency modulation. This could be achieved by adding a miniature pentode tube as the oscillator and operating the 6AG7 as a frequency doubler to drive the 807's.

Building a transmitter having plug-in RF units introduces some mechanical problems, such as cutting a large hole in the panel through which the RF unit is plugged in; and the necessity of maintaining close tolerances in positioning the power and RF output plugs at the rear of the RF unit. All the RF circuitry should fit into a somewhat smaller chassis—say 5 x 10 x 3 inches—when some of the extras we've included in our RF units are transferred to the fixed portion of the transmitter.

Still another mechanical layout which shows promise is to construct an RF unit containing all components except those which change in value for the different bands. Coils for a specific band could then be placed in a plug-in tuning unit having shields between them. Thus, tuning units could be assembled for only those bands in which the constructor is interested.

Each of the transmitters described elsewhere differed slightly in parts layout, indicating that as long as the usual precautions against stray coupling between stages and making all RF leads as short as possible are followed, a successful transmitter will result. We've simply brought out the foregoing random ideas for those amateurs who desire to build something different and possess a measure of mechanical ingenuity, plus reasonably well-equipped shop facilities.



G-E HAM NEWS

Available **FREE** from

G-E Electronic Tube Distributors

published bi-monthly by
ELECTRONIC COMPONENTS DIVISION

GENERAL  ELECTRIC

Schenectady 5, N. Y.

In Canada
CANADIAN GENERAL ELECTRIC CO., LTD.
189 Dufferin St., Toronto 3, Ontario

E. A. NEAL, W2JZK—EDITOR

JANUARY-FEBRUARY, 1958

Printed in U.S.A.

VOL. 13—NO. 1