

TRI-RANGE VFO



The slogan to remember when building oscillator tank circuits is "Keep 'em cool and solid, OMI!" By placing the tubes outside the box, W2RMM does just that with this versatile VFO which covers three ranges to multiply into all popular amateur bands.

—*Lighthouse Larry*

CONTENTS

Tri-Range VFO.....	page 2
1955 Edison Award Winner, W2JIO.....	page 6
Sweeping the Spectrum.....	page 7
Operation Crystal.....	page 8

TRI-RANGE VFO

DESIGN CONSIDERATIONS

As stated on page 1, vibration and heat are the enemies of many things, including stability of the frequency determining circuits in variable frequency oscillators. Three ways to declare war on these foes include: Solid mechanical construction, use of insulating materials with low thermal expansion rates and removal of all heat-producing components from the area of the tank circuit box. The last step is accomplished by placing the tubes on a separate chassis fastened to the rear of the cabinet housing the VFO, shown in Fig. 1.

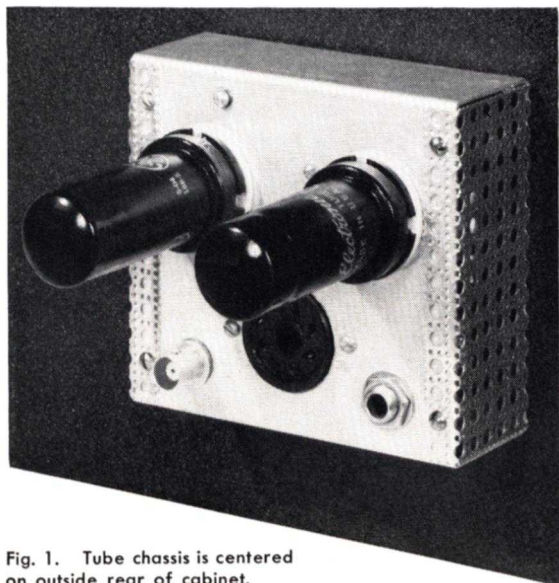

Fig. 1. Tube chassis is centered on outside rear of cabinet.

Solid mechanical construction is a necessity if you dare to move a muscle after setting the VFO on frequency. Let's open the little black box pictured on the cover and illustrate our point. Reasonable mechanical rigidity can be obtained by housing the tank circuits in a 4 x 5 x 6-inch aluminum utility box, when a few extra self-tapping screws are used to hold the two halves of the box together. Adequate rear support is obtained from a simple *tailskid* made from hardwood or insulating board, pictured in Fig. 2. If your taste in mechanical rigidity is more elaborate, a fancy home made box fashioned from sheet aluminum at least $\frac{1}{8}$ -inch thick is indicated.

Obtaining good quality ceramic insulated components is a simple shop-and-swap process. Silvered mica fixed capacitors and a double bearing main tuning capacitor with a wide air gap are essential ingredients. Even though a standard capacitor was used in our model, similar multi-section units are available on the surplus market. The high frequency end of each tuning range will be spread out in this particular circuit if the capacitor has a midline rotor plate shape. Also, a dial with a moveable scale and fixed pointer must be used to place the low frequency end of each range at the left side of the dial. A capacitor with semi-circular plates will have a more linear tuning rate and permits use of a dial with a fixed scale and moveable pointer.

This type dial may be calibrated directly in frequency, but many amateurs distrust this refinement. The reasoning—it's better to check your operating frequency with your receiver and a 100-kilocycle crystal

calibrator than to depend on setting the VFO dial where you believe the correct frequency to be.

Experimental work performed during the development of this VFO indicated that coils wound on ceramic forms caused only a fraction of the frequency drift measured when plastic insulated coils were substituted. Steatite pillar standoff insulators make excellent coil forms when the coil wire is shrunk onto the form. Winding instructions are given under "MECHANICAL DETAILS." Shining a heat lamp or reflector type flood-lamp on the tank circuits for a moment when the oscillator is running will show up any frequency drift in a hurry. Applying heat in this manner is an excellent method of determining the value of temperature compensating capacitors which should be used if the tank circuit box is to be placed where it will be exposed to extreme temperature variations.

CIRCUIT DETAILS

The popular series-tuned Colpitts pentode oscillator circuit, shown in the schematic diagram, Fig. 3, is capable of excellent frequency stability. Three tuning ranges—1.75-2.0, 3.37-3.71 and 4.0-4.5 megacycles—are given full dial coverage by *tailoring* a separate tank circuit for each range. Band selector switch S_1 connects the desired frequency determining components to the grid of the 6AG7 oscillator tube. Stability is improved by keeping this switch out of the critical portion of the frequency determining circuit. Each section of a three-gang variable capacitor, C_1 , paralleled with fixed and variable padding capacitors, series-tunes the oscillator coils.

The plate circuit load for the oscillator is simply a 2.5-millihenry RF choke, capacity coupled to the grid of the 6V6. This tube operates as an amplifier on 1.8—2.0 megacycles and a doubler in the 3.5—4.0, 7.0—7.3 and 8.0—9.0 megacycle ranges. The tuned plate circuit for this stage combines two paralleled capacitors, C_{13} and C_{15} , in series with variable capacitor C_{14} across coil L_4 to cover 3.5—9.0 megacycles. Rotating C_{14} from near maximum to minimum capacity covers this range. A corner of one rotor plate is bent to short-circuit this capacitor at maximum capacity, connecting C_{13} and C_{15} across L_4 to tune the 1.8—2.0-megacycle range. Capacitor C_{13} need be adjusted only once for each 25-kilocycle segment in this band. Output may be taken directly from C_{12} at the plate of the 6V6 through J_3 if the external coaxial cable length is less than 2 feet.

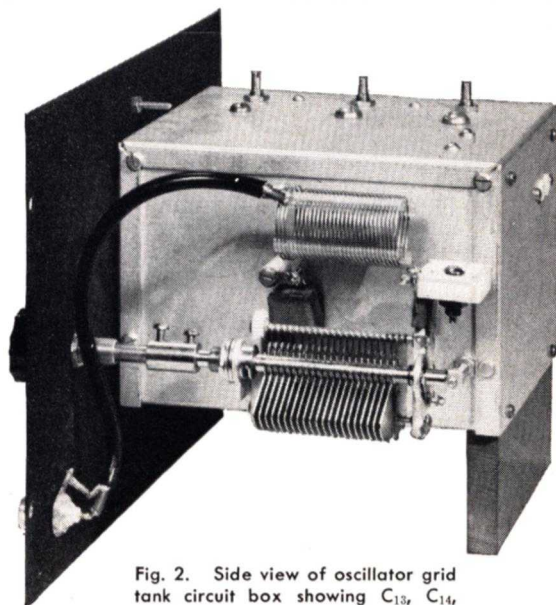

Fig. 2. Side view of oscillator grid tank circuit box showing C_{13} , C_{14} , C_{15} , L_4 attached to removable cover.

A coupling coil, L_5 , feeds the output through J_4 when a longer cable is desired.

Oscillator cathode keying may be used if only a simple RF filter is necessary to eliminate clicks. A lag-type click filter may cause the oscillator to chirp. No chirp should result from a break-in system which keys succeeding stages while the oscillator runs continuously during each transmission. A key or meter jack, J_2 , is included in the cathode circuit of the 6V6.

MECHANICAL DETAILS

Main tuning capacitor C_1 is mounted on the half of the tank circuit box having the 4 x 5-inch ends. A hole for the shaft was drilled in the front of the box $1\frac{1}{4}$ inches from the right side. Each grid coil and its related padding capacitors fasten next to the corresponding section of the tuning capacitor.

The hole for bandswitch S_1 was drilled $1\frac{1}{4}$ inches from the bottom and $\frac{7}{8}$ inches from the left side of the box. Next, the box is positioned 1 inch down from the top and $1\frac{1}{4}$ inches in from the left side of the panel. Matching holes are drilled in the panel for these two controls and the bearing for the vernier drive shaft. Holes for the shaft extension from C_{14} , positioned to provide balance for the bandswitch knob, and coaxial jack cable jack J_4 are also drilled before assembly. All

plate tank circuit components for the 6V6 mount on C_{14} , which fastens to the side of the shield box with 8-32 x 1-inch long machine screws as standoffs. Padder capacitor C_{13} mounts on a small brass angle bracket soldered to a stator lug on C_{14} . A $\frac{3}{4}$ -inch high steatite pillar insulator supports the cold end of L_4 , pictured in the box illustration on page 2. The crystal socket for the 6AG7 grid connections, J_1 , mounts on the rear wall of this box.

The tube sockets and connection jacks are mounted on a $4\frac{1}{8}$ x $3\frac{3}{4}$ x $1\frac{1}{2}$ -inch deep miniature aluminum chassis, drilled according to Fig. 5. This chassis is held in place with machine screws driven through the rear of the cabinet into 6-32 tapped holes in each corner of the bottom lip. Parts with wire leads are fastened to lugs on their related parts, pictured in Fig. 6, and to small insulated terminal posts. A shield made from perforated aluminum sheet which covers the bottom and open sides of the chassis is assembled before the chassis is attached to the cabinet.

A mounting base for each oscillator coil form is fashioned from $\frac{3}{4}$ -inch long sections of plastic rod cut from a Bud No. I-1906 lucite standoff insulator. The threaded hole through the center is re-tapped to match the $\frac{1}{4}$ -20 thread in the ceramic forms. A long soldering lug is placed between the plastic base and ceramic form

PARTS LIST

- $C_{1a, b, c}$ —6-35-mmfd, 3-section variable (Bud MC-887)
- C_2, C_3, C_4 —2.7-19.6-mmfd midget variable (Johnson 20M11 or Hammarlund MAC-20)
- C_5, C_{12} —50-mmfd silvered mica
- C_6 —70-mmfd silvered mica
- C_7 —30-mmfd silvered mica
- C_8 —800-mmfd silvered mica (500- and 300-mmfd in parallel)
- C_9 —1200-mmfd silvered mica (1000- and 200-mmfd in parallel)

- C_{10}, C_{11} —100-mmfd silvered mica
- C_{13} —100-500-mmfd mica padder
- C_{14} —13.5-320-mmfd variable (Hammarlund MC-325-M)
- C_{15} —500-mmfd silvered mica
- J_1 —crystal socket for 0.093-inch diameter pins spaced 0.486 inches.
- J_2 —closed circuit phone jack
- J_3, J_4 —chassis coaxial receptacle
- S_1 —2-pole, 6-position miniature tap switch with stop set for 3 positions (Centralab PA-2019)

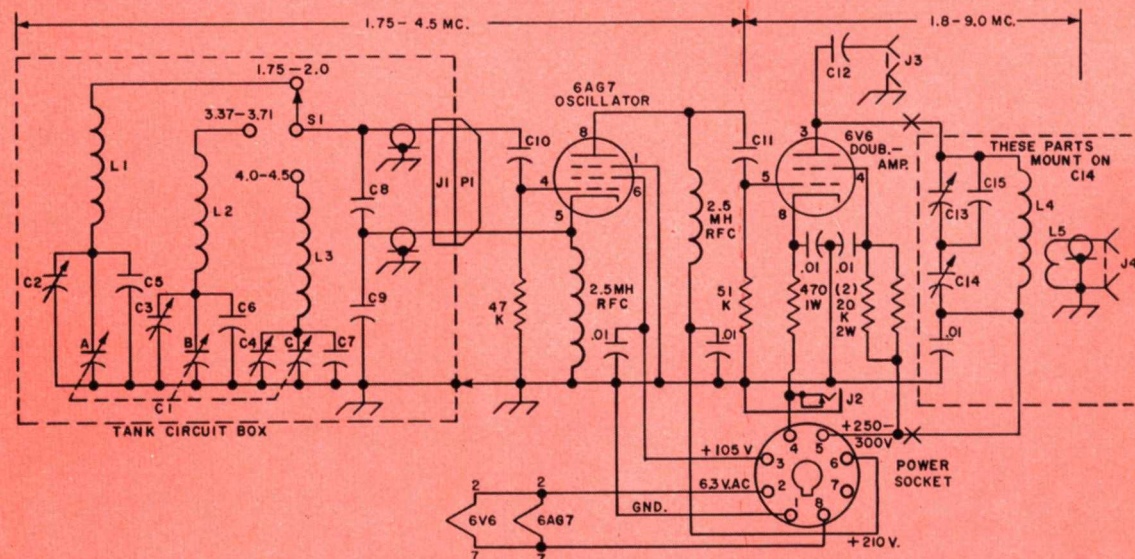

Fig. 3. Complete schematic diagram.

COIL TABLE

(Wind L_1 , L_2 and L_3 according to instructions in "MECHANICAL DETAILS")

- L_1 —100 turns No. 24 Formex enameled wire, closewound on a 1-inch diameter steatite pillar insulator 2 1/2 inches long. (Centralab X-32) (27 feet of wire)

- L_2, L_3 —43 turns, No. 20 Formex enameled wire, closewound on a 1-inch diameter steatite pillar insulator 2 inches long. (Centralab X-31) (12 feet of wire)
- L_4, L_5 —30 turns No. 20 tinned wire, 1-inch diameter, 16 turns per inch. Count 25 1/2 turns, cut wire and unwind 1/4 turn for leads at each end, for L_4 . Use remaining 4 turns for L_5 , also with 1/4-turn leads connecting to coaxial cable. (B & W No. 3015 or air-dux No. 816-T)

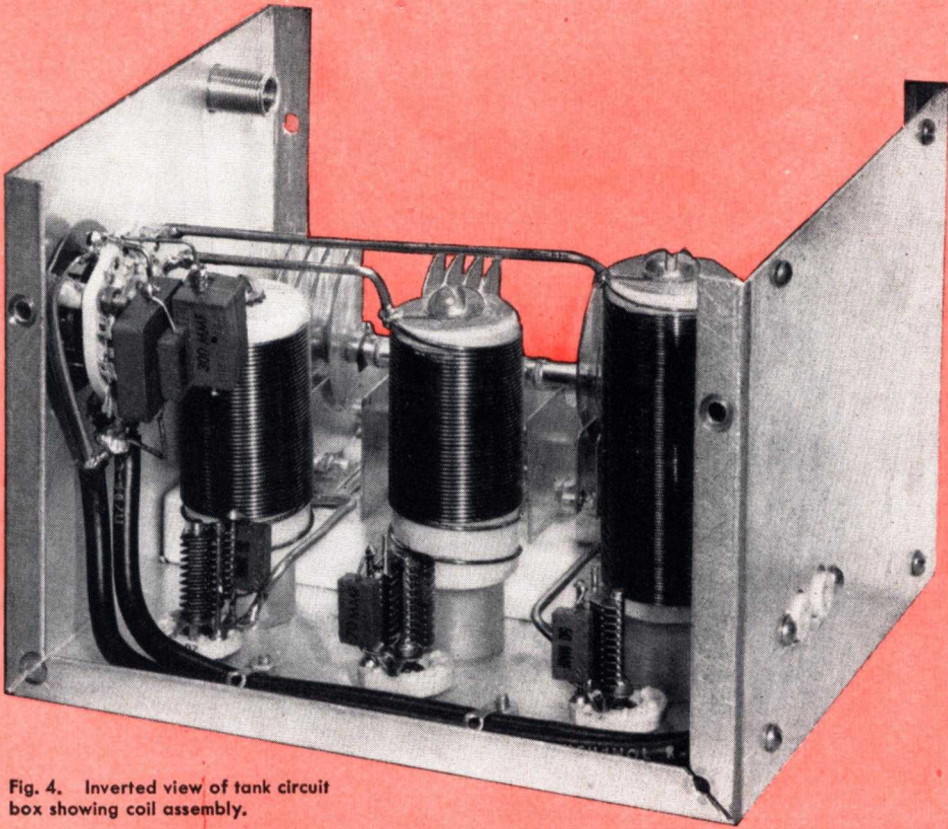

Fig. 4. Inverted view of tank circuit box showing coil assembly.

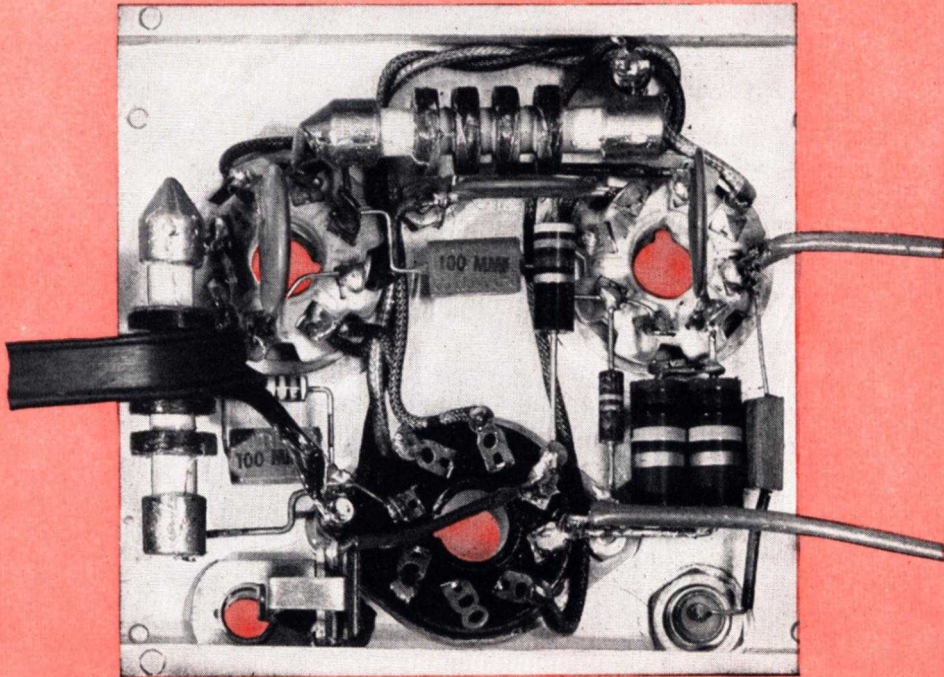

Fig. 6. Bottom view of the tube chassis.

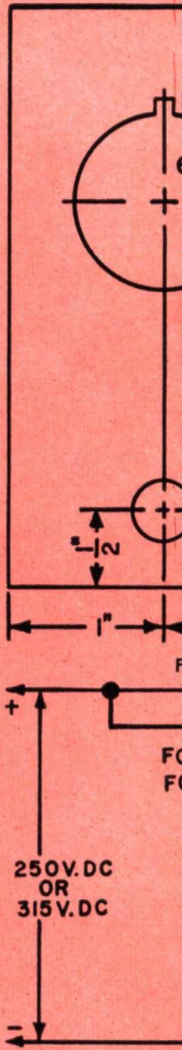

Fig. 7. Su

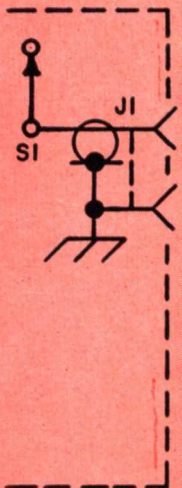

Fig. 8. C

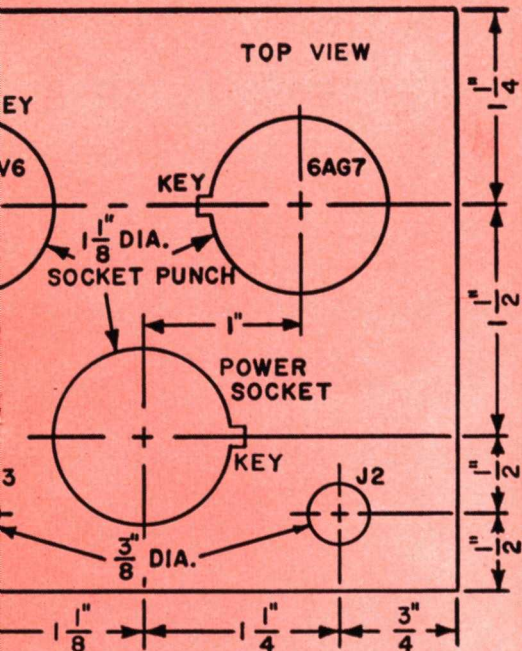
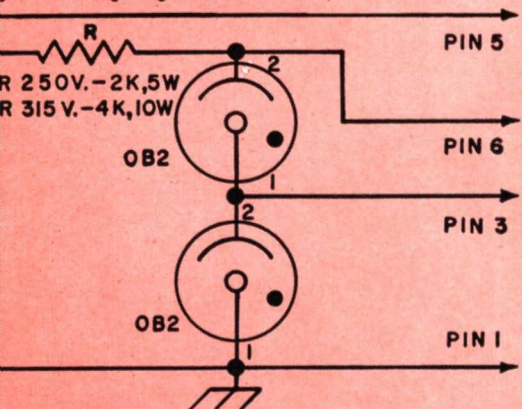
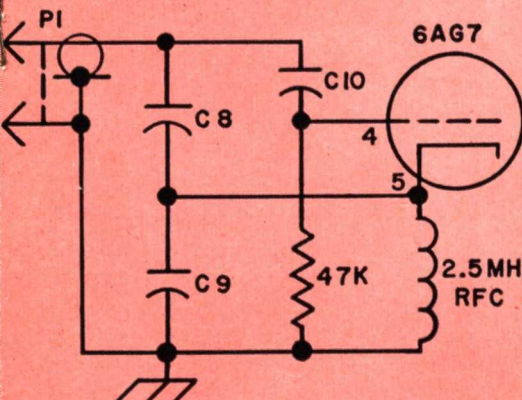

Fig. 5. Drilling diagram for tube chassis.



Suggested voltage regulator tube circuit for the VFO.



Circuit changes for using coaxial connecting cable.

before they are assembled with a short threaded stud. A short machine screw holds a similar lug at the other end of the form. A coating of coil cement covers the unglazed ends of the steatite when these parts are assembled. After winding, the completed assembly is held in the shield box by a short machine screw which must not touch the stud holding the base and form together.

If you have three or more hands, you probably can wind the coils tightly without help. The following two-man method worked fine on the coils shown on page 4. Measure the approximate length of wire needed and clamp one end to a rigid object. Solder the loose end of the wire to the lug at the base of the form. One person then stretches the wire taut with a few husky tugs and prepares to wind the coil. The second person holds a heat lamp or soldering iron close to the wire just ahead of the coil winder. The coil winder should wear gloves to avoid burning his hands in case the wire gets very hot. When the proper number of turns has been counted, the winder keeps the wire taut while the second person removes the enamel from the wire. The bare wire is then wrapped around and soldered to the other lug. As soon as the wire cools, two or three turns at each end are cemented in place, but the entire coil is *not* covered with cement.

WIRING DETAILS

Tinned No. 12 wire is used for all connections in the tank circuit box, except for RG-58/U coaxial cable leads from capacitors C_8 and C_9 to the crystal socket. All power connections on the tube chassis are made with colored hookup wire. A short length of 300-ohm twinlead, soldered to pin 5 on the 6AG7 socket and an insulated terminal to which one end of C_{10} is fastened, plugs into the crystal socket. A matching plug or two pins from an octal tube base are soldered to the other end of the twinlead. Leads made from short lengths of RG-58/U cable with the shielded braid removed connect the 6V6 to its plate tank circuit. These leads and the short twin lead run through rubber grommets in the rear of the cabinet.

OPERATION

A voltage-regulated source for the oscillator screen and plate also will improve the frequency stability of this VFO. A pair of OB2 regulator tubes and a resistor, connected as shown in Fig. 7, may be easily added to most power supplies. After a final wiring check and connecting the power cable, the tubes are inserted and power applied. A well-calibrated receiver and 100-kilocycle frequency standard simplifies adjusting the frequency coverage to suit your particular needs. Trimmer capacitors C_2 , C_3 and C_4 may be adjusted so that the oscillator will not tune outside your favorite amateur band limits. For example, if you operate near 3.5 megacycles, set C_1 at maximum capacity, S_1 on the 1.75-megacycle position and adjust C_2 until the oscillator frequency is slightly above 1.75 megacycles.

If you wish to place the tube chassis several feet from the tank circuit box, two lengths of coaxial cable should be used for connecting these units in place of the short twinlead. A single coaxial cable will suffice if C_8 and C_9 are moved to the tube chassis, shown in Fig. 8. The shunting capacity of the cable must be subtracted from the series value of these capacitors in either case, otherwise the frequency coverage in each tuning range will be altered. For instance, the series capacity of C_8 and C_9 is 480 mmf, determined by the formula: $C_1 = \frac{C_8 \times C_9}{C_8 + C_9}$. Subtracting the 228 mmf capacity of 8 feet of RG-58/U cable, the new value for C_1 is 252 mmf. Cranking the formula in reverse indicates a value of 420 mmf for C_8 and 630 mmf for C_9 . A single *unknown* can be used for C_8 and C_9 because the ratio between these capacitors does not change.

1955 EDISON AWARD



Winner Robert W. Gundersen, W2JIO, "reads" his tube tester (top right) by listening to audio tones generated by his tube checker adapter, one of the more than 30 types of special test equipment he has developed (bottom left) which enable blind persons to earn a living in the expanding electronics field. These devices also use Braille-calibrated dials.

His full schedule of activities includes: Editing and publishing the 15,000-word monthly magazine for other sightless engineers, technicians and amateurs, *The Braille Technical Press*, for which he is shown "proofreading" copy (below) with XYL Lillian—also the non-profit publishing corporation's secretary-treasurer; teaching 3 nights a week at the New York Institute for the Education of Blind; ham radio consultant 3 days weekly at Hudson Radio & Television stores in New York City; manufacturing test gear for blind persons in his "spare" time (bottom right); and working his home station on several bands (middle right).

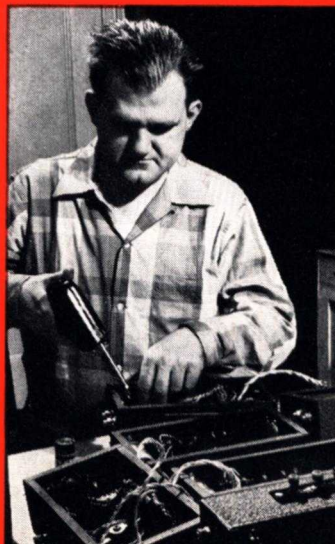
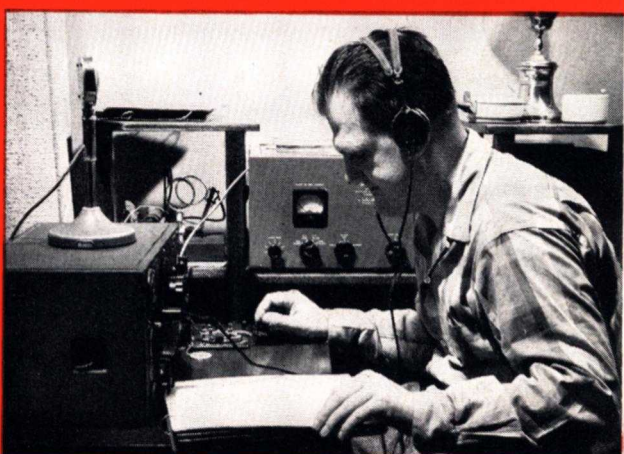
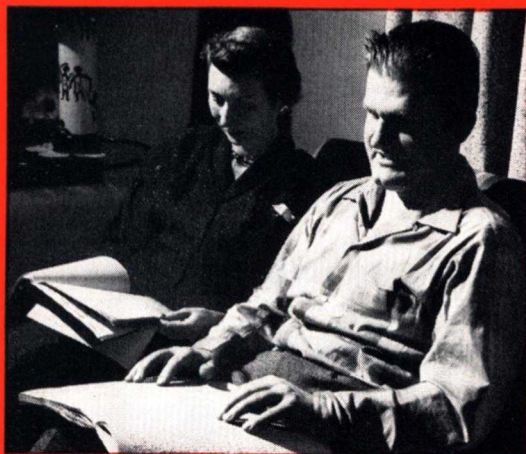
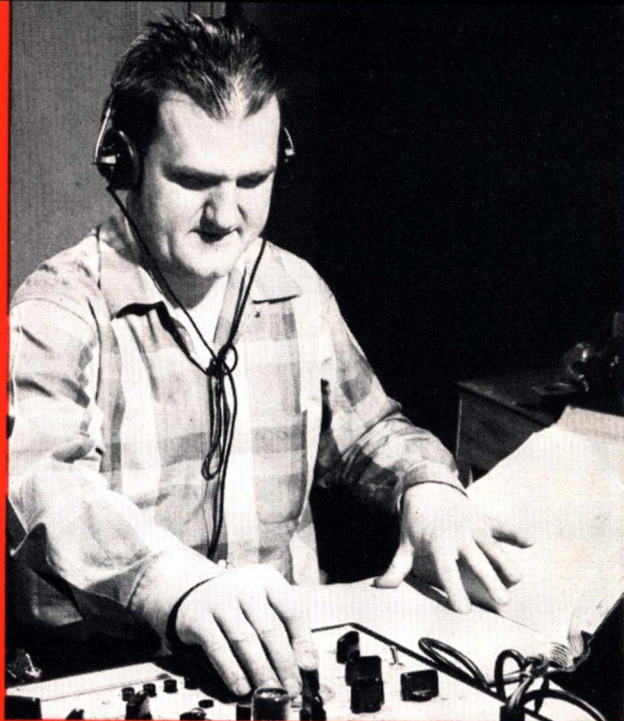

JUDGES

E. ROLAND HARRIMAN
President, The American Red Cross

HERBERT HOOVER, JR., W6ZH/K6EV
The Under Secretary, U. S. Department of State

EDWARD M. WEBSTER
Commissioner, Federal Communications Commission

GOODWIN L. DOSLAND, WØTSN,
President, American Radio Relay League

SWEEPING *the* SPECTRUM



Replying to many recent queries whether our Log Form QSL card offer will continue, I want to make clear the fact that these cards will be available as long as you OMs (and YLs too) keep sending in those dollars for packages of 300 cards. Drop me a postcard for a sample if you haven't seen them, or this column in the Volume 10, Nos. 4 and 5 issues of G-E HAM NEWS.

When you order Log Form QSL cards and also request some back issues of G-E HAM NEWS or technical data on tubes (we have that too!), these items are mailed in separate packages. Why? I send you the back issues from my office and have the QSL cards shipped from our warehouse, which means they may arrive at your QTH several days apart.

* * *

Congratulations to the eight 1955 Edison Radio Amateur Award Special Citation winners who were chosen by the judges after careful deliberation. The following amateurs were cited for their outstanding emergency communications work during the 1955 flood disasters: Paul M. Crown, Jr., W3YAZ; Alfred E. Guardiani, W1TTN; Roland E. Lemire, W1TZO; Murton W. Lyon, W1BGT; Lewis J. Papp, W3MAC; and Stephen P. Temby, K6IRE.

Also named were: Louis Arivello, W ϕ CPI, for his traffic handling work during which he has received 39 consecutive Brass Pounders League certificates; and George F. Beard, K6HCI, who has helped more than 240 novices obtain their licenses, furnishing much of the equipment needed to conduct his classes.

The Edison Award Judges also voted to award disaster citations to the hundreds of radio amateurs who participated in group emergency work and also helped *police* the frequencies being used for this purpose. The text of this citation will be published in national magazines, as records do not exist for awarding these citations on an individual basis.

More nominations were received this year than ever before in the four-year history of the Edison Award. The deadline for receiving nominations was extended from January 2 to January 10, so that Northern California area amateurs could receive recognition for emergency operations during the December floods. Much of the work in this area was continued into 1956, making these amateurs eligible as candidates for the 1956 award nominations.

Nominating letters should include complete details of the public service rendered, plus newspaper clippings or documents giving additional details. Photostats of these items may be submitted. If the originals are sent in, they will be returned upon request. Believe me, *now* is the time to start collecting that nomination material!!

* * *

The recent shift of emphasis in Civil Defense preparations from "digging in" to evacuation alters the

requirements for Radio Amateur Civil Emergency service communications equipment in most areas. Mobile rigs will be necessary to provide adequate communications in place of the fixed stations that many civil defense groups now have installed. If your equipment was originally designed for DC operation from storage batteries, mobile mountings and control circuits may be the only changes needed.

But, whether you have RACES gear or simply a "super home-brew" mobile rig in mind, some good construction ideas can be found by simply studying the novel unitized assembly of the G-E "Progress Line" of two-way mobile radio equipment, which can now be found in many vehicles equipped with that communications medium.

The same idea can be easily carried out in the assembly of equipment for your RACES and other emergency network installations. A simple rack into which your units mount can be adapted from the several types still available as war-surplus, or you can build a rack from angle iron and shock mounts. Standard cable connectors should be substituted for the *mongrels* found on surplus equipment. Another handy item: Add a pair of carrying handles wherever convenient. You may want to haul the gear to some strategic location on foot. Lastly, make provision for connecting the rig to a fixed antenna for improved coverage when the mobile temporarily serves in a fixed location.

* * *

The multitude of opportunities in electronics engineering careers that will be available to young men now completing high school or early college terms was forcibly emphasized the other day when the boss (that's the editor) showed me a prediction recently made by Charles M. Young, Manager of Engineering for the G-E Power Tube Sub-Department here in Schenectady. He stated, "In the next ten years, we will increase our manufactured products to four times their present volume, largely in the area of new products."

A quick check told me that this new product growth highlights the 15—20% expansion per year in engineering personnel and facilities in each of the three sub-departments in the G-E Tube family: Receiving, Power and Cathode Ray. Design projects aimed at the development of new microwave devices, ceramic receiving and color television picture tubes; power systems; plus materials and processes; calls for engineering experience in electrical engineering, physics, ceramics, metallurgy and physical chemistry; as well as the seemingly more related fields of cathodes, vacuum systems and plain, down-to-earth electronic tube engineering.

What I am leading up to, if you have taken a sly peek between the above lines, is that engineering staff openings at the seven G-E Tube Plants are constantly occurring. Persons qualified in the above fields, not now engaged in national defense projects, are invited to inquire about these opportunities. Address your request to me and I will see that it reaches the proper hands.

—Lighthouse Larry



OPERATION CRYSTAL

Availability of a new low-cost transistor, the G-E 2N107, makes practical the publishing of circuits using these units. At the top right, a conventional crystal detector feeds a transistor audio amplifier. Substituting the transistor detector at the lower right, connected at points A to D, will increase the headphone volume several times. Introducing regeneration as shown below by wrapping an 8-turn feedback coil around the fiber sleeve of a vari-loopstick produces a noticeable increase in gain and selectivity. Reverse the connections or add a few more turns to the feedback coil if regeneration is non-existent at first. This detector also can be connected to the amplifier through an audio transformer in place of the headphones.

Thanks to Bob Nelson, W ϕ KLG, Dassel, Minn.; Charles Cutter, Nashua, N. H.; and Larry Dworsky, Bronx, N. Y., for sending in ideas used in these circuits.

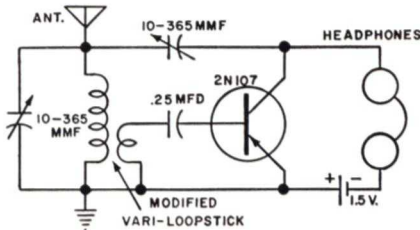
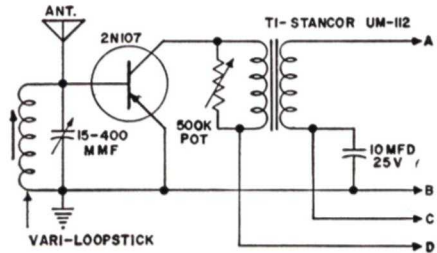
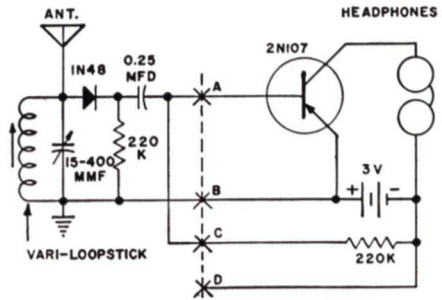

Even though OPERATION CRYSTAL has officially ended, the boss is keeping me on the job to check interesting crystal and transistor circuit ideas, also material submitted for the TRICKS and TOPICS, and QUESTIONS and ANSWERS columns. Certificates for \$10 in G-E Tubes will be awarded for ideas published in G-E HAM NEWS.

—Danny Diode



G-E HAM NEWS

Available FREE from

G-E Electronic Tube Distributors

published bi-monthly by

TUBE DEPARTMENT

GENERAL ELECTRIC

Schenectady 5, N. Y.

In Canada
Canadian General Electric Co., Ltd.
Toronto, Ontario

E. A. NEAL, W2JZK—EDITOR

MARCH—APRIL, 1956

Printed in the U. S. A.

VOL. 11—NO. 2

If You Didn't Get This From My Site,
Then It Was Stolen From...

www.SteamPoweredRadio.Com