



G-E HAM NEWS

Copyright 1955, by General Electric Company
If You Didn't Get This From My Site,
Then It Was Stolen From...
www.SteamPoweredRadio.Com

TUBE DEPARTMENT
GENERAL ELECTRIC
Schenectady 3, N. Y.

JULY-AUGUST, 1955

VOL. 10-NO. 4

A 6-METER SPECTACULAR—Part I “TECHNICIANS’ DELIGHT” TRANSCEIVER

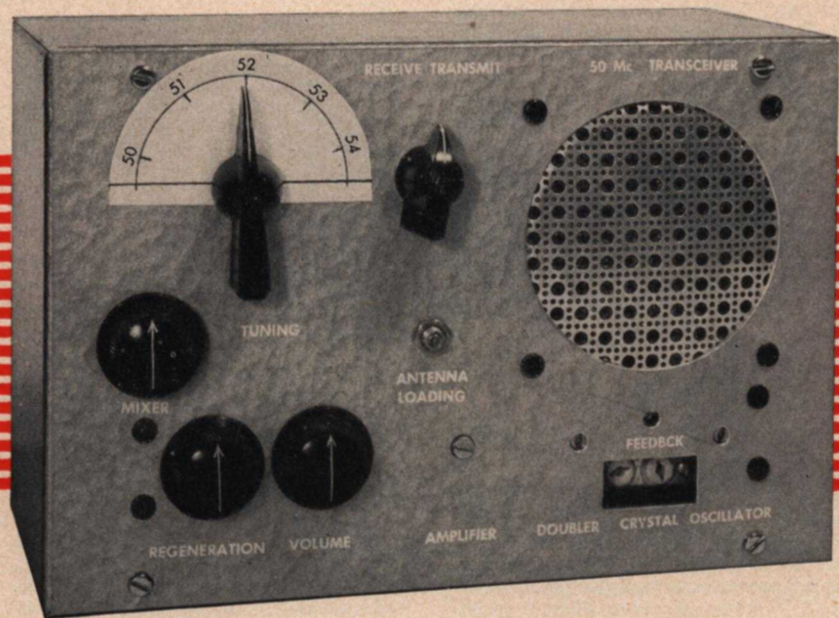

Part I is a complete 6-meter station in one package from the bench of W2GYV that features a simple six-tube circuit, 4.5 MC fixed-frequency superregenerative detector, speaker doubling as a microphone and a novel “pi-network” overtone oscillator circuit. The next issue will feature Part II, the “Simple-sixer Serious Converter”; and the November-December issue will present Part III, the “Bonus 100-watt Transmitter.”

—Lighthouse Larry

CONTENTS

“Operation Crystal”	page 2
Technicians' Delight Transceiver	page 3
Sweeping the Spectrum	page 7
Transceiver Test Meter	page 8

OPERATION CRYSTAL



Have you ever wondered how more than one germanium diode would work in a crystal receiver. Well, I found out when tests were made on these entries I received recently. Fig. 1 is a full-wave detector using a split coil and a 2-section tuning capacitor, which can be any old broadcast type ranging from about 10 to 400 mmf. L_1 is 45 turns of No. 32 insulated wire wound in the middle of a 6-inch long, $1\frac{1}{4}$ -inch diameter form. L_2 and L_3 each have 140 turns wound either side and spaced $\frac{1}{8}$ inch from L_1 . All coils are wound in the same direction. The series antenna capacitors, C_1 , a 15-400-mmf variable, and C_3 , a 500-mmf fixed, help resonate most any antenna and ground system. Les Trude, W2GXV, of Clyde, N. Y., submitted the first of several full-wave circuits received.

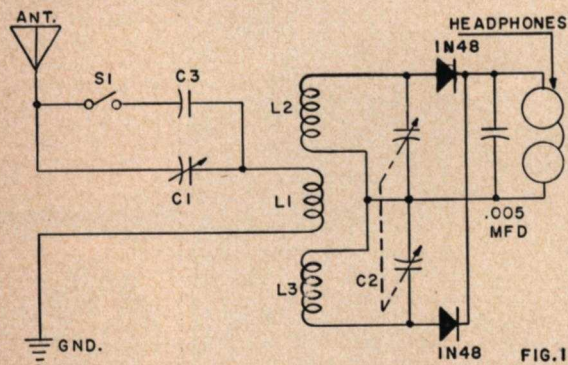

FIG. 1

The circuit shown below makes use of a bridge-type detector circuit which, when tested, showed greater selectivity than a single crystal connected across the same tuned circuit. The audio output voltage was about the same for either detector. The selectivity becomes greater and sensitivity decreases as the spacing between the coils is increased. The two vari-loop sticks may be placed either end to end or parallel with about $\frac{1}{2}$ -inch spacing center to center. J. L. Knaus of Glassport, Pa., submitted this circuit.

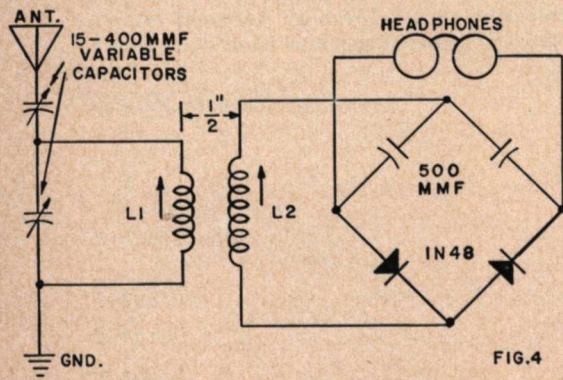

FIG. 4

The simplest two-crystal circuit I have received came from R. J. Baker, W8JIA, North Industry, Ohio. Several of the local hams glanced at the circuit and told me, "Impossible!! There's no ground return path." So, try it yourself. It only takes a couple minutes. If you have more than one local broadcast station, the optional tuned circuit will help separate them. Even in the form shown in the solid lines in Fig. 2, high output was obtained with only a few feet of wire for an antenna.

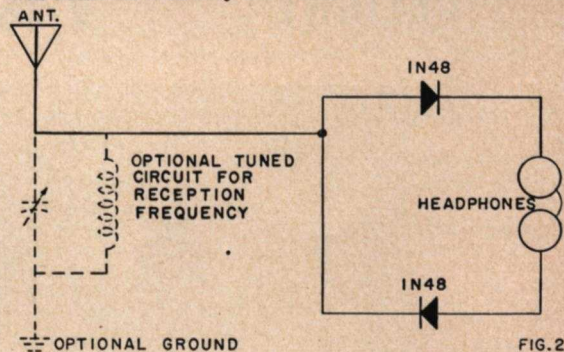

FIG. 2

W8JIA also submitted a design with one crystal and high selectivity, shown in Fig. 3. The coils are wound on a G-E tube carton $1\frac{9}{16}$ -inches square. L_1 is 50 turns of No. 26 wire, L_2 is 25 turns spaced $\frac{1}{8}$ inch from L_1 and L_3 is 60 turns spaced $\frac{1}{8}$ inch from L_2 . All the variable capacitors are separate—and for simplicity the two in the antenna circuit could be the mica-padding type.

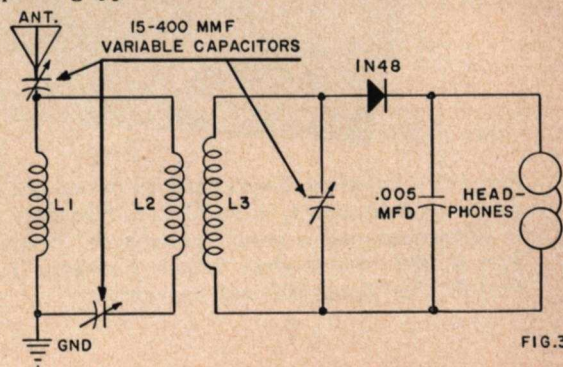

FIG. 3

All ideas submitted before December 1, 1955, will be eligible for publication in the OPERATION CRYSTAL Column. (See G-E HAM NEWS, Volume 10, No. 1.) Do not send in your model! Submitters of the three ideas published in each issue receive certificates for \$10 in G-E Electronic Tubes. Be sure to give complete coil-winding data for home-wound coils. All material submitted must be free from patent restrictions and becomes the property of G-E HAM NEWS.

—Danny Diode

"TECHNICIANS' DELIGHT" TRANSCEIVER

This simple transceiver has many possibilities as a general-purpose 6-meter rig for Technician class amateur radio licensees who want to take advantage of their recently-granted privileges on this band. It should particularly interest those who have no regular station receiver into which a converter may be used.

The original idea was that a few of the local gang wanted to build these units and leave them running all the time for a little private communications network. When the first model was tested, the receiver sensitivity was well above expectations—and the rig seemed to be a *natural* for the above-mentioned purpose.

The reliable working range between two of these units over fairly level terrain using a simple ground-plane antenna at roof-top height seems to be ten to fifteen miles. This set would also be useful for CD communications installations located where only one two-way radio unit is needed. As the power requirements were tailored to fit the popular 300-volt, 100-milliampere vibrator-type plate supply, it will run for many hours on one "filling" of a storage battery. The heater power requirement is only 2.4 amperes at 6.3 volts. Total plate power drain at 300 volts is 50 ma on the "receive" position and 100 ma on the "transmit" position. The high efficiency G-E HAM NEWS Mobile Portable Power Supply described in Volume 8, No. 2, would be ideal for powering this rig from 6 volts.

RECEIVER CIRCUIT

The schematic diagram, Fig. 1, shows that only six tubes are required for this transceiver, with the audio section serving a dual role as plate modulator and receiver audio amplifier. The receiver section uses a 12AT7 mixer-oscillator with the IF output at 4.5 megacycles. The high frequency oscillator tunes on the low side of the 50 to 54 megacycle signal frequency to minimize image difficulties in areas where TV channel 2 is in use. Mixer grid circuit tuning capacitor (C_1) was not ganged to oscillator capacitor (C_2) to eliminate tracking problems. Normally, C_1 will only have to be touched when more than a half megacycle frequency change is made in the oscillator tuning.

A standard 4.5 megacycle television sound discriminator transformer couples into a fixed-frequency superregenerative detector. This circuit will be remembered by many old-timers as being notorious for radiation of "squeals" and a lack of selectivity when operated at a VHF signal frequency. Working it at 4.5 megacycles and isolating this circuit from the antenna overcomes these disadvantages. The desirable properties of good sensitivity, ignition noise rejection and inherent AVC action make possible a good performing but simple receiver circuit.

For the information of "new-timers," this detector is simply an oscillator at 4.5 megacycles in which the values of the grid resistor and capacitor have been increased to the point where a "squegging" action, or second oscillation takes place simultaneously about 20 KC. The grid capacitor accumulates a high negative charge which decreases at a slow rate through the high value grid resistor, varying the oscillator's operating point. In a normal regenerative detector, further amplification ceases when oscillations commence. The superregenerative detector can oscillate at the signal frequency only when this negative grid charge decreases to the point where the grid is no longer biased beyond cutoff. Thus, the regeneration can be greatly increased with a large amount of amplification resulting.

One half of another 12AT7 handles this function, the

second section being used as an audio voltage amplifier. A 6V6 beam-pentode audio output stage provides plenty of drive for the 45-ohm voice coil, 3½-inch PM speaker.

TRANSMITTER CIRCUIT

The transmitter section uses a third 12AT7 as an overtone crystal oscillator and frequency doubler. Novel use of a pi-network tank circuit is made to provide feedback for encouraging third-overtone operation of any crystal ground for fundamental operation between 8334 and 9000 KC.

Variable air capacitor C_3 tunes the network to the 25 megacycle output frequency and mica padder capacitor C_4 allows easy and precise adjustment of the proper amount of feedback necessary for overtone output from highly active or extremely sluggish crystals. Tests indicate that this circuit is much simpler to adjust than more conventional types in which juggling a coil-tap or separate feedback coil is required. Feedback is at a minimum when this padder is at maximum capacity.

The other half of this 12AT7 in a conventional frequency doubler provides about 3 ma grid current for the 5763 Class C power amplifier.

Another pi-network tank circuit is used for the amplifier output, to simplify the problem of providing mechanical means of varying the antenna loading. Parallel feed is used to isolate the plate voltage from the output circuit. While a conventional parallel-tuned tank circuit with a balanced link output might be more desirable for feeding the rig into a 300-ohm twin-lead, the unbalanced output circuit can be fed into a small antenna coupler or line-balancing balun made from coaxial cable. Antenna switching to the receiver input is also handled more easily with the unbalanced circuit.

As a safety measure, enough cathode bias is provided on each transmitter stage to keep the plate dissipation within reason when no crystal is plugged in or the tank circuits are off resonance.

Provision for metering the doubler and amplifier grid currents, the amplifier cathode current and the plate supply voltage is made by placing appropriate resistors in these circuits. Leads from these resistors connect to an octal socket installed in the rear of the chassis. The same test meter used with the G-E HAM NEWS 6-meter C-D transmitter (see page 8, also Volume 7, No. 1 for details) can be plugged into this socket when tuning up the transmitter. Test prods inserted in the appropriate socket holes can also be connected to the 10-volt DC scale on a multimeter.

AUDIO CIRCUITS

Plate and screen modulation of the final amplifier was felt to be more desirable for this type of transmitter, where every watt of output really counts, than the lower efficiency of *clamp-tube* modulation. The 6V6 was chosen as a Class A audio amplifier because it carries ratings up to 315 volts in this application. If the rig is to be run at 250 volts or less, the 6AQ5 miniature-tube version would suffice.

When transmitting, the speaker is switched from the secondary of the output transformer to the cathode of one section of a fourth 12AT7, which runs as grounded-grid voltage amplifier. The output of this stage feeds the voltage amplifier stage used for both receiving and transmitting. The other half of this tube is not used.

The audio output transformer, T_2 , also serves as a center-tapped modulation choke. The 47-ohm resistor switched across the voice-coil winding in the "transmit" position *ties down* the secondary.

If the rig is to be used for occasional mobile operation in either an under-dash or on-the-seat installation, the speaker would be too far away from the operator to be conveniently used as a microphone. So, a closed-circuit type 'phone jack is provided in the cathode of the transmitter voltage amplifier. When a single-button carbon microphone is plugged in, the speaker is dis-

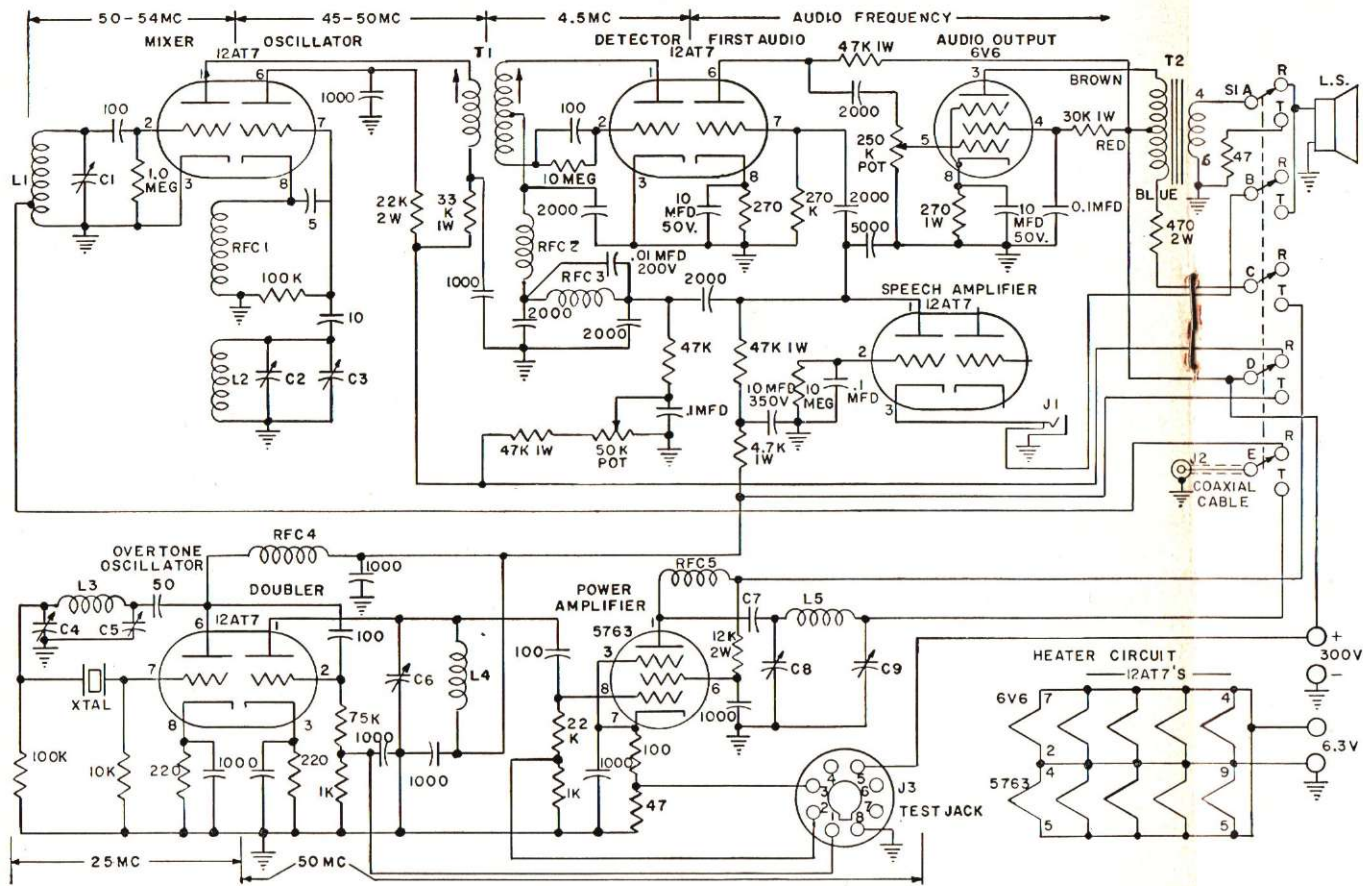

Fig. 1—Circuit diagram.

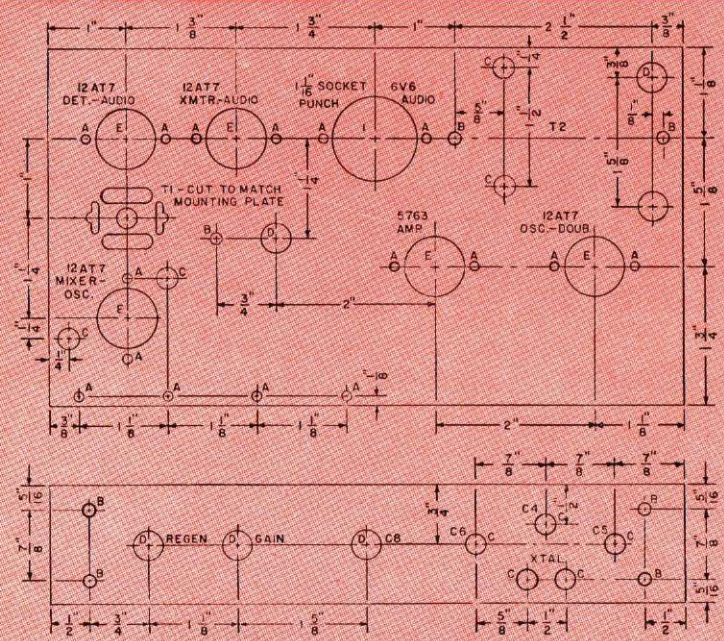

Fig. 2—Chassis drilling diagram.

COIL TABLE

- L₁—8 turns No. 16 enameled wire 1/2-inch inside diameter—5/8-inch long—tapped 1 1/2 turns from ground end.
- L₂—4 turns No. 16 enameled wire 1/2-inch inside diameter—3/8-inch long.
- L₃—15 turns No. 16 enameled wire 5/8-inch inside diameter—1 1/8-inch long.
- L₄, L₅—6 turns No. 16 enameled wire 1/2-inch inside diameter—5/8-inch long, 2-inch leads on L₅.

LEGEND

- "A" drill—No. 32 spaced to fit tube sockets.
- "B" drill—No. 26 as shown.
- "C" drill—1/4-inch diameter.
- "D" drill—3/8-inch diameter.
- "E" socket punch—3/4-inch diameter.

PARTS LIST

- C₁—1.8–8.7 mmf Variable Midget Capacitor (Johnson 9 M II Cat. 160–104).
 - C₂—2.3–14.2 mmf Variable Midget Capacitor (Johnson 15 M II Cat. 160–107).
 - C₃—15–130 mmf Variable Mica Padder Capacitor (El Menco 302-M).
 - C₄, C₉—65–340 mmf Variable Mica Padder Capacitor (El Menco 303-M).
 - C₅, C₆—2.7–19.6 mmf Variable Midget Capacitor (Johnson 20 M II Cat. 160–110).
 - C₇—1000 mmf, 1000-volt working disk ceramic.
 - C₈—3.5–27 mmf Variable Capacitor—0.030-inch air gap (Johnson 25 L 15 Cat. 167–102).
 - J₁—Midget closed-circuit 'phone jack.
 - J₂—Chassis-type coaxial cable jack.
 - J₃—Octal tube socket with ground lugs.
 - LS—3 1/2" PM speaker, 45-ohm voice coil.
 - RFC₁, RFC₅—7 uh RF choke (Ohmite Z-50).
 - RFC₂—1 mh RF choke (Miller No. 952).
 - RFC₃—16 mh RF choke (Meissner 19–1995).
 - RFC₄—1 mh RF choke (National R-100).
 - S₁—6-pole, 2-position steatite miniature Rotary Selector Switch, non-shorting (Centralab PA-2019).
 - T₁—4.5 megacycle TV Replacement Sound Discriminator Transformer (Miller No. 6204).
 - T₂—18-watt universal speaker output transformer (Stancor A-3852).
 - Xtal—Quartz crystal 8334 to 9000 KC with socket to match.
- All capacitors in mmf 600-volt disk ceramic unless otherwise specified. Capacitors marked in mfd are 600-volt paper. Electrolytic capacitors are marked in mfd and voltage rating. All resistors 1/2-watt unless otherwise specified. K=1000, Meg.=megohms.

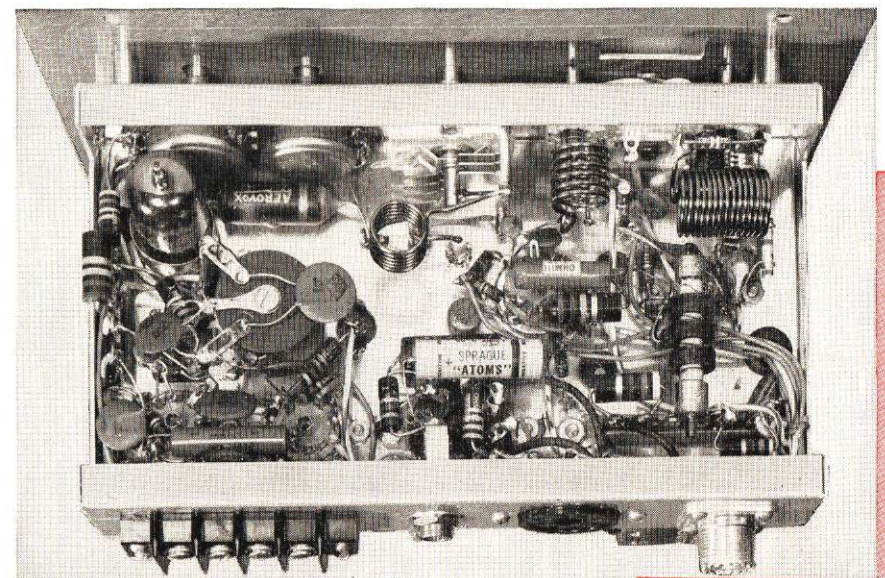

Fig. 3—Bottom view of chassis. RFC₅ is the large disk at the right of the inverted mixer tube.

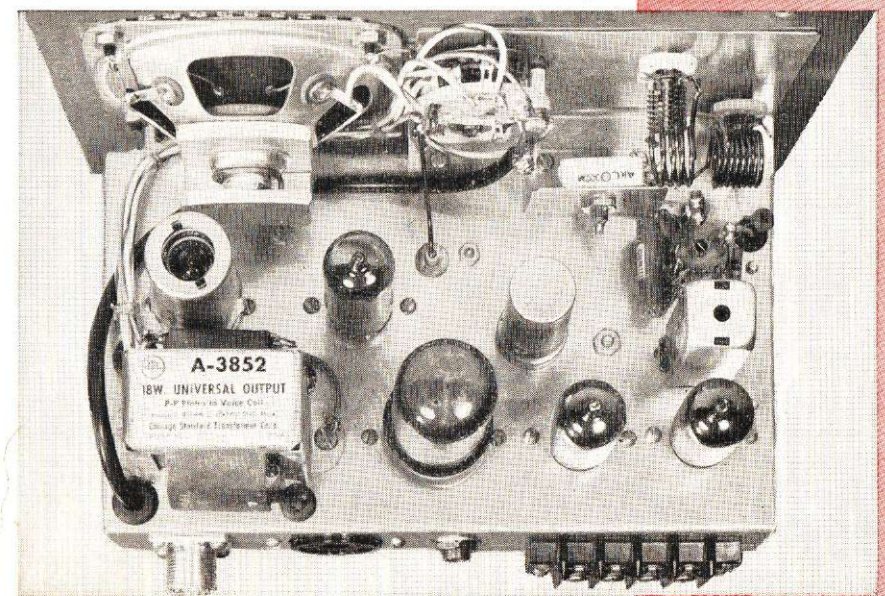

Fig. 4—Top view of chassis. A 6V6-GT audio output tube was used in the test model.

connected from this circuit. The cathode current of this stage then supplies the required microphone current.

S_1 is assigned a great variety of tasks and handles the plate supply switching job easily when ceramic insulation is used. In the "receive" position it connects the antenna to the mixer grid coil, applies plate voltage to the mixer, oscillator and detector. Also, it connects the speaker to the audio amplifier output. In the "transmit" position, it connects the antenna to the final amplifier, applies plate voltage to the oscillator-doubler, applies modulated voltage to the final amplifier plate and screen and connects the speaker as a microphone.

CONSTRUCTION

The entire gear is easily housed in a 6 x 9 x 5-inch utility box. If much portable work is planned with this unit, the aluminum box used in the cover model is preferable to a steel one, weighing about two pounds less. All parts mount on either the removable front panel or a $4\frac{1}{2}$ x 8 x $1\frac{1}{2}$ -inch open-end aluminum chassis, drilled as shown in Fig. 2.

The mounting plate furnished with T_1 is used as a drilling and filing template to cut identical holes in the chassis and is then discarded. The transformer is then fastened directly to the chassis with the furnished spring clip.

The lower panel edge is located $\frac{3}{4}$ inch down from the bottom of the chassis and matching $\frac{1}{4}$ -inch holes are drilled for all parts except the crystal socket. A $\frac{1}{2}$ x $1\frac{1}{4}$ -inch panel cutout allows the crystal to be plugged in. Holes for C_2 and S_1 are located $1\frac{1}{2}$ inches down from the panel top edge, with C_2 $2\frac{1}{4}$ inches from the side. S_1 is centered on the panel and C_3 locates $\frac{3}{4}$ inches directly below it. C_1 is mounted $1\frac{1}{8}$ inches from the panel edge and $1\frac{1}{2}$ inches below C_3 .

A piece of thin sheet aluminum, 4 x 4 inches, bent into an angle bracket and fastened to the front of the chassis, provides a good RF ground path for C_1 , C_2 , C_3 and S_1 . C_3 mounts on another small aluminum angle bracket fastened with the same screws which hold the larger bracket.

A 3-inch diameter hole for the speaker is bored in the panel with a circle cutter centered $2\frac{1}{8}$ inches down and $2\frac{1}{4}$ inches in from the panel edges, and covered with a small square of perforated do-it-yourself aluminum sheet.

All parts can now be fastened to the chassis front edge and the panel mounted after $\frac{3}{8}$ -inch long spacers cut from $\frac{1}{4}$ -inch OD tubing are slipped over the 6-32 x $\frac{3}{4}$ -inch long machine screws. Both potentiometer shafts are trimmed to protrude about $\frac{5}{8}$ of an inch.

Both RFC₂ and RFC₃ fasten on a single 6-32 x $1\frac{1}{2}$ -inch long machine screw as shown in the bottom view, Fig. 3. The mixer-oscillator tube socket is inverted to allow short RF leads pictured in the top view, Fig. 4. The larger capacitors and resistors fasten to a 4- and a 6-terminal tie-point fastened under convenient mounting screws. The power terminal strip, microphone jack, metering socket and antenna connector mount on the rear of the chassis and matching holes are cut in the back cover of the utility box to clear these parts.

Power and audio wiring connections to S_1 are laid and run through two rubber grommets near T_2 and along the edge of the chassis to the switch, to avoid the RF circuits. All coils are air-wound and mount directly on their associated tuning capacitors. One end of L_4 is connected to a tie-point terminal so that the 1000-mmf by-pass capacitor and plate voltage lead can be wired. Short leads connect the antenna transfer switch section to loading capacitor C_9 and the tap on mixer grid coil L_1 . A short length of RG-58/U coaxial cable connects the switch and antenna connector J_2 .

RECEIVER ADJUSTMENT

The heater wiring should be tested before the rest of the wiring is completed so that any alterations can be made more easily. Before plate power is applied, a cali-

brated grid-dip oscillator is very handy for adjusting the tuned circuits to the correct frequency range. With C_2 set at the proper point, C_3 should tune the oscillator between 45 and 50 megacycles with the constants shown. Switch S_1 can now be set in the "receive" position, with the mixer-oscillator tube removed and plate voltage applied to the unit. With the volume control set at the mid-position, the 50,000-ohm potentiometer controlling the superregenerative detector plate voltage should be advanced until a sharp hiss becomes noticeable. If no hiss is present, a grid-dip oscillator or other signal generator should be closely coupled to the detector and tuned from approximately 4 to 5 megacycles to see if a beat-note can be heard when the plate-voltage control is fully advanced. If this is the case, a higher resistance than the 10 megohms specified may be necessary to initiate a superregenerative type oscillation. RFC₃ and its associated by-pass capacitors form a filter that keeps the quench oscillation out of the audio circuits.

If a signal generator is not readily available, two or three feet of wire clipped on pin 6 of the mixer tube socket should provide enough pickup of outside signals in the 4 to 5 megacycle range to check the operation of the detector. The mixer-oscillator tube then can be inserted and the detector set to a clear frequency by tuning the slug on the bottom of the IF transformer. The mixer plate circuit slug on the top of the transformer should then be tuned until the detector goes out of oscillation when the resonant frequency is passed. Raising the detector plate voltage slightly should again cause the detector to oscillate. With the detector grid circuit values specified, oscillation should begin when the plate-voltage control is advanced about halfway. On the test model, a reading of 60 volts was measured at the center tap of the IF transformer secondary.

Dial calibration of the receiver oscillator can best be done with harmonics of a crystal frequency standard or signals of known frequency.

TRANSMITTER ADJUSTMENT

The test meter, shown in Fig. 5, can now be plugged into the metering socket, with the selector switch set on position one. The 12AT7 oscillator-doubler and 5763 amplifier tubes are inserted in their sockets and S_1 turned to the "transmit" position. A fundamental type crystal between 8334 and 9000 KC or a third-overtone crystal between 25 and 27 megacycles is plugged into the crystal socket. Feedback capacitor C_4 is then set about two turns from maximum capacity and oscillator tuning capacitor C_5 rotated until a reading of 2 to 3 grid ma is noted in the 0- to 10-ma range of the test meter. Then the feedback capacitor can be slowly adjusted for increasing capacity until oscillation stops. The final setting should be about one-quarter turn toward minimum capacity from this point. The test meter should now be set on position two, also a 10-ma scale. A sharp increase in amplifier grid current should be noted when doubler tuning capacitor C_6 is next adjusted.

The test meter is now set on position three, which reads the amplifier cathode current. A dummy load made from six 330-ohm, 2-watt composition resistors in parallel is connected to the antenna terminal.

With loading capacitor C_9 set at maximum capacity, C_8 is tuned to resonance. A reading of about 30 ma should be noted on the 100-ma full-scale meter range in position three. Capacitor C_9 should then be slowly decreased in capacity, keeping C_8 tuned for minimum cathode current, until the meter reads about 50 ma. After subtracting screen and grid currents, this indicates a plate input of 12 watts with a 300-volt plate supply. The test model delivered more than 7 watts output to a 52-ohm load when checked in the laboratory.

Two self-tapping screws driven from the back cover to the rear of the chassis when the gear is placed in the box will make the unit rigid.

Transceiver Test Meter

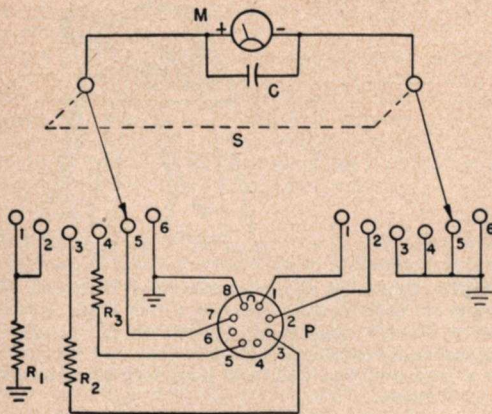

Fig. 5—Circuit diagram of test meter.

CIRCUIT CONSTANTS

C.....	270 mmf mica or high-K ceramic
M.....	0 to 1 ma d-c meter
P.....	Octal plug
R ₁	10,000 ohm, ½ watt (see text)
R ₂	5000 ohm, ½ watt (see text)
R ₃	1 megohm, 1 watt (see text)
S.....	Two-pole, six-position rotary switch

Since the test meter for the 6-meter CD transmitter (see G-E HAM NEWS, Volume 7, No. 1, for details), met the metering requirements for this unit, the circuit, shown in Fig. 5, is being repeated for those who do not have access to this issue. A few of these meters may be available in localities where these CD rigs are in use.

In switch positions 1 and 2, the resistor R₁ causes the meter to act as a 0 to 10 voltmeter; in switch position 3, resistor R₂ makes the meter into a 0 to 5 voltmeter; in switch position 4, resistor R₃ forms a voltmeter with the range 0 to 1000 volts; in switch position 5, the meter is used as a -0 to 1 milliammeter; in position 6 the meter is shorted (the recommended "off" position).

The following tabulation indicates the "current" and voltage which the meter reads when it is switched to the various positions:

Position 1: Full scale equals 10 ma doubler grid current.

Position 2: Full scale equals 10 ma final grid current.

Position 3: Full scale equals 100 ma final cathode current.

Position 4: Full scale equals 1000 volts plate voltage.

Position 5: Relative power output reading (Not used).

Position 6: Off.

For accurate scale readings, the resistors specified should be as accurate as possible. Strictly speaking, however, accuracy is not paramount, inasmuch as the metering system will undoubtedly be used mainly as a tune-up aid.



G-E HAM NEWS

Available FREE from

G-E Electronic Tube Distributors

published bi-monthly by

TUBE DEPARTMENT

GENERAL  ELECTRIC

Schenectady 5, N. Y.

In Canada
Canadian General Electric Co., Ltd.
Toronto, Ontario

E. A. NEAL, W2JZK—EDITOR

Printed in U.S.A.

VOL. 10—NO. 4

JULY—AUGUST, 1955

If You Didn't Get This From My Site,
Then It Was Stolen From...

www.SteamPoweredRadio.Com