



Electronic
TUBE

HAM NEWS



Copyright 1949, By General Electric Company
If You Didn't Get This From My Site,
Then It Was Stolen From...

SEPTEMBER—OCTOBER, 1949

www.SteamPoweredRadio.Com

VOL. 4—NO. 5

RESTRICTED RANGE SPEECH AMPLIFIER

Audio Amplifier Designed Expressly for Speech Work

FEATURES—

- "Speech" range from 500-2500 cycles
- Minimum distortion
- Five miniature tubes—one rectifier
- Power output of 10 watts

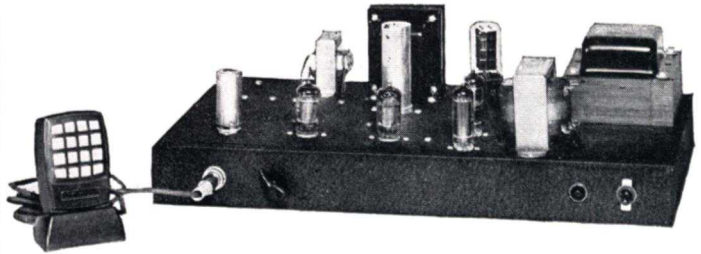

Fig. 1. Front View of the Restricted-range Speech Amplifier

GENERAL CONSIDERATIONS

A speech amplifier for amateur radio service has the job of amplifying the human voice until the complex waveform which forms the human voice has sufficient power to drive the modulator tubes. The amplifier's job, then, is relatively simple. However, the frequency characteristic of the audio amplifier—that is, the amount of amplification which will be obtained at various audio frequencies—determines to a large degree the type of radio-frequency signal which is put on the air.

For example, if you are using a speech amplifier capable of amplifying frequencies beyond ten thousand cycles, and your voice (or extraneous background noise) contains energy at this frequency, then the radio-frequency signal from your transmitter will extend out at least ten thousand cycles—10 kilocycles—on each side of your transmitted radio frequency. Stated another way, your signal has a minimum width of 20 kilocycles. Broad? Quite broad. Even aside from the fact that you have a broad signal, there is little point in transmitting a high fidelity signal. Primarily this is because the average communication receiver does not have an audio system capable of reproducing these high frequencies.

In addition, a highly selective receiver will further restrict the audio frequency characteristic.

If you use another amplifier which has practically no gain at 10,000 cycles, but which drops rapidly in gain past 5000 cycles, then this same voice, using this amplifier, will modulate the radio-frequency carrier so that energy exists out 5 kilocycles each side of the center frequency. This gives a signal with a width of 10 kilocycles. By using this second amplifier, have you lost naturalness, does your voice sound exactly the same to the amateur receiving it over the air as it would if he heard you in person? No. Can you be understood? Yes.

How far can this process be carried? How much can we restrict the bandwidth of the speech amplifier, and still have voice modulation which is adequate for communication purposes? While it is impossible to give an answer to this question which will satisfy everyone, most engineers agree that a bandwidth, for understandable speech, of 500 to 2500 cycles is adequate. This is not as narrow a band as might be imagined. For example, the major radio networks send their programs to their member stations on telephone lines. The best of these lines have a cutoff frequency of approximately 5000 cycles. Certainly

CONTENTS

Restricted Range Speech Amplifier.....	pages 1-4
Tricks and Topics (Cleaning Old Sockets; Refinishing Panels; Joint Unsoldering).....	page 5
Questions and Answers (Suffix "W"; C-R Tube Numbering; Glass Tube Numbers; Battery-Operated Tubes).....	page 6
Sweeping the Spectrum.....	page 7
Technical Data (12AX7).....	page 8

ELECTRICAL CIRCUIT

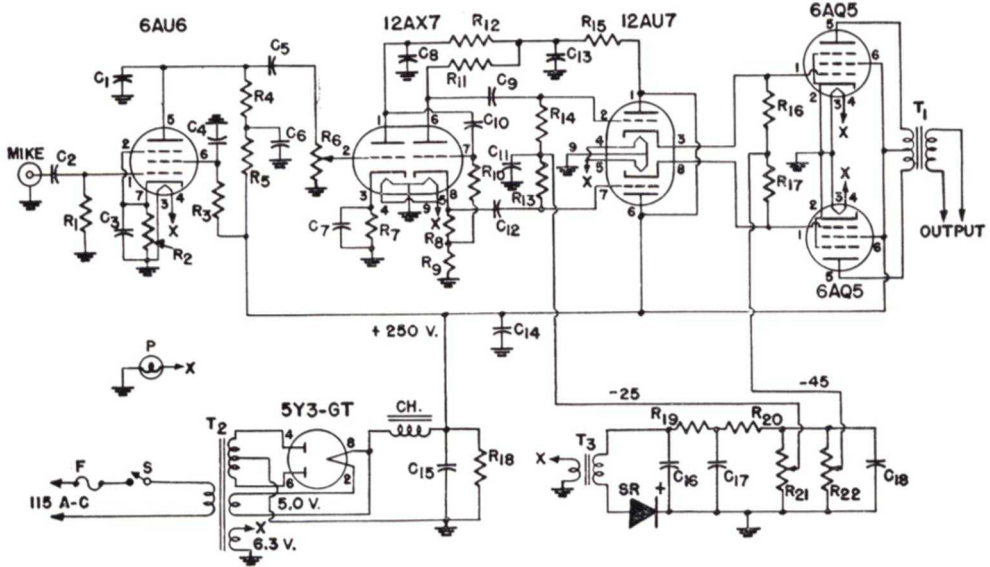

Fig. 2. Circuit Diagram of the Restricted-range Speech Amplifier

CIRCUIT CONSTANTS

C ₁1590 mmf mica (see text)	R ₇3500 ohm, 1 watt
C ₂0.005 mf 600 volt paper	R ₈2500 ohm, 1/2 watt
C ₃ , C ₇50 mf 50 volt electrolytic	R ₉17,500 ohm, 1/2 watt
C ₄ , C ₆ , C ₁₃ , C ₁₄8 mf 450 volt electrolytic	R ₁₀0.1 megohm, 1 watt
C ₅1275 mmf mica (see text)	R ₁₁20,000 ohm, 1 watt
C ₈1380 mmf mica (see text)	R ₁₂0.33 megohm, 1 watt
C ₉ , C ₁₂0.01 mf 600 volt paper	R ₁₃ , R ₁₄0.5 megohm, 1/2 watt
C ₁₀580 mmf mica (see text)	R ₁₅6600 ohm, 6 watt (three 20,000 ohm, 2 watt resistors in parallel)
C ₁₁0.1 mf 600 volt paper	R ₁₆ , R ₁₇6000 ohm, 1 watt
C ₁₅40 mf 450 volt electrolytic	R ₁₈50,000 ohm, 10 watt
C ₁₆ , C ₁₇ , C ₁₈40 mf 150 volt electrolytic	R ₁₉ , R ₂₀1000 ohm, 2 watt
CH.....8 henry smoothing choke, 150 mils	R ₂₁ , R ₂₂10,000 ohm, 10 watt semi-adjustable
F.....2 ampere fuse	S.....SPST toggle switch
P.....6.3 volt pilot light	SR.....Selenium rectifier (G-E 6RS5GH2)
R ₁1 megohm, 1/2 watt	T ₁Output transformer (see text)
R ₂5500 ohm, 1 watt	T ₂Power transformer, 350-350 at 150 mils, 6.3 volts at 4 amperes, 5.0 volts at 3 amperes
R ₃0.47 megohm, 1 watt	T ₃Filament transformer, 6.3 volts at 1 ampere
R ₄47,000 ohm, 1/2 watt	
R ₅10,000 ohm, 1 watt	
R ₆0.25 megohm potentiometer	

we do not think of network broadcasts as having "poor quality," and yet 5000 cycles (approximately) is the highest audio tone which will be heard when listening to network programs.

The primary advantage in using a speech amplifier which has a restricted high-frequency response is that the radio-frequency signal resulting will occupy less space in the spectrum. Recent FCC amateur proposals which refer to the bandwidth of radio-frequency signals (on which no action has been taken at the time of this writing) can be complied with most easily by sufficient reduction in the response of the speech amplifier at the higher audio frequencies. This is because the radio-frequency bandwidth of a properly operated transmitter is dependent only upon the range of the audio frequencies used to modulate the transmitter. This assumes that the transmitter is free of parasites, is operating on only one frequency, and the modulation applied is within the modulation

capability of the modulated stage, to cite a few of the effects which may give a broad signal, even though the modulating frequencies are within the proper range.

(However, in the case of NBFM, the use of a restricted-range speech amplifier will not assure that the radio-frequency signal does not occupy too much space. If the frequency swing caused by the modulation is excessive then the radio-frequency signal will be unnecessarily broad.)

Thus far we have discussed primarily the higher-frequency audio tones. However, it is also desirable to eliminate, or attenuate, the low frequency audio response of the speech amplifier. Elimination of all response below, say, 500 cycles, would have no effect on the width of our radio-frequency signal, but it would give us the effect of a stronger signal. It is difficult to put an actual number on the gain which could be achieved, but with relatively simple attenua-

tion means used in the speech amplifier a gain of 5 to 6 decibels would be possible. This is the sort of gain which can be expected from a good two-element parasitically excited beam, or by increasing your power by a factor of four.

The energy output of the male voice is concentrated at the lower frequency end of the audio frequency spectrum. Unfortunately these low frequency components of the male voice contribute little to the intelligence in speech. However, being of high amplitude, a great deal of modulator power and modulation capability is required to transmit them. Obviously we can increase the effective transmitted power by reducing the number of low frequency components in the system. Paradoxically a system with restricted high-frequency response, such as discussed previously, sounds more natural if the low frequency components are attenuated in a balanced manner.

There are many ways to accomplish the desired attenuation of the lower and higher frequency portions of the audio-frequency spectrum. All of these methods use an audio network, either simple or complex, which will attenuate certain frequencies either more or less than other frequencies. The amount of attenuation achieved will depend upon the type of network used.

Referring again to the April 27 FCC proposals no statement has been made public, at the time of this writing, as to the amount of attenuation that the FCC feel is adequate. The attenuation achieved in the amplifier about to be described is shown in Fig. 3. This attenuation averages 12 db per octave. Stated another way, the power is down by a factor of sixteen for each octave considered. For example, the power output of the speech amplifier at 10,000 cycles is one-sixteenth of the power output at 5000 cycles.

Referring again to Fig. 3, the calculated operating range of the speech amplifier is from 500 to 2500 cycles. Note that the curve is not flat over this portion, but that the 500 and 2500 cycle points are approximately 6 db down from the midpoint frequency, which is approximately 1000 cycles. For the first octave below 500 cycles and the first octave above 2500 cycles, the attenuation has not yet reached a slope of 12 db per octave. However, for further octave jumps the attenuation will be quite close to 12 db per octave, so that the 125 and 10,000 cycle points will be down by 26 db and the 62 and 20,000 cycle points down by 38 db.

Note this 62 cycle point. The attenuation at this point is theoretically 38 db or, as actually measured in the speech amplifier, 35 db. This means that the power output at 62 cycles will be only one four-thousandth of the power output at 1000 cycles. This

means that normal precautions regarding sixty cycle hum need not be taken. As a result, the filament wires in this speech amplifier were neither paired and twisted nor carefully handled. One side of each filament connection was grounded and the other lead run as a single wire. While this may not seem startling, those of you who have had trouble with hum in high-gain amplifiers will appreciate this statement.

The design procedure used in this speech amplifier is identical to that discussed in the "Technical Tidbits" section of the July-August, 1949 G-E Ham News. Readers are referred to this article for the background work on the present design. Suffice it to say that C_5 and C_{10} (see Fig. 2) have the job of attenuating the low frequency end of the audio spectrum, and C_1 and C_8 handle the attenuation of the higher audio frequencies. In other words, the entire job is handled by the proper choice of four condensers, two of which would normally be employed in the amplifier even if a restricted bandwidth were not desired.

ELECTRICAL DETAILS

Referring to the circuit diagram, Fig. 2, the tube functions are as follows. The 6AU6 serves as a pentode voltage amplifier, giving a mid-band gain of well over 100. The first section of the high- μ double-triode 12AX7 serves as the second voltage amplifier, and gives a gain of approximately 50. The second section of the same tube acts as a phase inverter. The 12AU7 tube is a push-pull cathode follower which acts as a low-impedance driving source for the push-pull 6AQ5 output tubes. It is absolutely essential that distortion be held to as low a value as possible if full advantage is made of the restricted bandwidth of this speech amplifier. This is because distortion will cause the radio-frequency signal to become broad, and this is one of the effects that we wished to overcome by restricting the audio bandwidth.

One of the major causes of distortion in the audio systems of amateur transmitters is the use of driver stages with too high an internal impedance to properly drive class AB₁ or Class B stages. Distortion results, in this case, because of poor regulation in the driving voltage when the driver is called upon to supply the grid current drawn during voltage peaks. The 12AU7 cathode follower tube acts as a *low-impedance* driver. This permits more power output from the 6AQ5 tubes with less distortion than would be possible if the 6AQ5 tubes were driven directly from the phase inverter.

Essentially the 6AQ5 tubes are operated as class AB₁ amplifiers. Normally this means that no precautions need be taken with the driver stage to ensure minimum distortion provided that the grids are

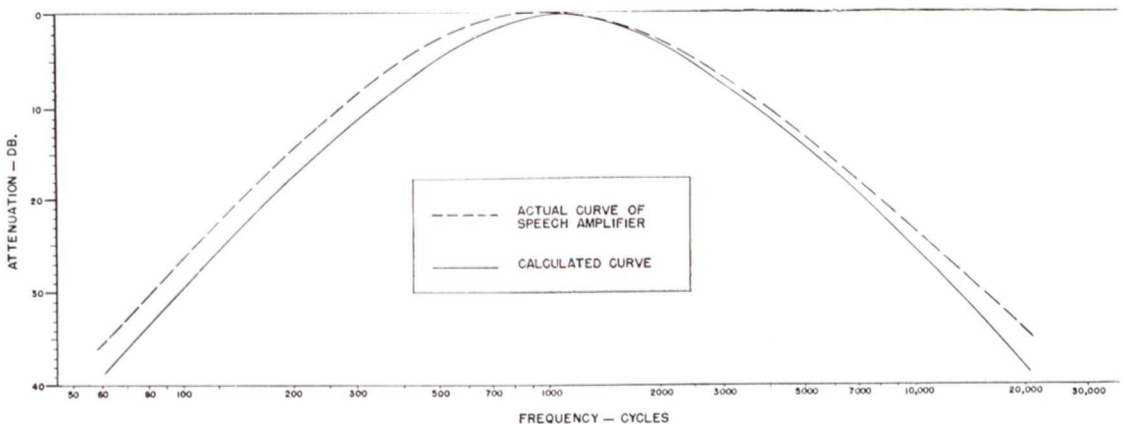

Fig. 3. Theoretical and Actual Frequency Response Curve for the Restricted-range Speech Amplifier

never driven positive. This condition is difficult to achieve unless the average level is kept quite low. By using a driver which presents a low source impedance, which the 12AU7 accomplishes, the average level may be pushed up quite high and the 6AQ5 tubes driven all the way up to the grid bias point. Even if an occasional voice peak causes this voltage point to be exceeded, no distortion will occur due to "folding-up" of the driver stage. The net result is high output, minimum distortion, and a "narrow" radio-frequency signal.

Condensers C_1 , C_5 , C_8 and C_{10} (the frequency controlling condensers) are listed in "Circuit Constants" with values which are not stock values. The values shown are those which calculation indicate to be correct. Try to obtain condensers moderately close to these values. It is not wise to trust the values marked on condensers, and it is recommended that a capacitance bridge be borrowed to check through your stock of mica condensers. It may be easier to parallel condensers in order to get the proper value. For example, C_1 could easily be made up with a 1000 mmf and a 600 mmf condenser in parallel.

One further point might be made, with reference again to the circuit diagram. Fixed bias is supplied to two stages, the 12AU7 stage and the 6AQ5 stage. The bias supply is unusual in one respect. Cathode current for the 12AU7 stage must flow through R_{22} . The total current for both 12AU7 sections is approximately 10 mls. In other words, this bias supply must be capable of supplying a voltage and a current, instead of just a voltage as in the usual case. If the circuit diagram is followed no difficulty will be encountered. However, if you attempt to use another source of bias, make certain that it can supply the required current.

MECHANICAL DETAILS

The amplifier was constructed on a 17 by 10 by 2 inch chassis. However, inasmuch as practically any layout scheme will work, the prospective builder can

use any convenient size chassis and change the layout to suit. The entire speech amplifier and power supply could fit easily in a chassis of half the size of the one just mentioned.

The placement of parts can best be seen in Fig. 1. The tubes are, from left to right, 6AU6, 12AX7, 12AU7, 6AQ5's, and the 5Y3-GT rectifier tube in the rear. Note that the 6AU6 uses a shield. On the rear of the chassis, at the left, is the bias transformer, T_3 , with the choke and C_{15} to the right. The power transformer occupies the rear corner and the output transformer is directly ahead of it.

Only two controls are employed—the on-off switch and the gain control. The microphone input jack and the pilot light are mounted on the front of the chassis, and the fuse on the rear of the chassis.

The underchassis view of the amplifier, Fig. 4, indicates the placement of the remainder of the components. No shielded wire was used, mainly because all leads to the first two stages were short. If the layout is altered from that indicated, it might be advisable to shield any long leads in the first two or three stages.

OPERATING ADJUSTMENTS

Once the amplifier has been completed, and it has been established that voltage can be applied without anything smoking, the 12AU7 bias voltage and cathode-return voltage should be adjusted. R_{21} should be adjusted so that the bias, as read from the arm of R_{21} to ground, is 25 volts. Adjust R_{22} until the voltage from the arm of R_{22} to ground is 45 volts. Next check the bias on the 6AQ5 tubes by reading the voltage from pin 1 of either tube to ground. This voltage should be 15 volts. If this is not true, change the tap on R_{21} slightly until the 6AQ5 bias (pin 1 to ground) reads 15 volts. The 45 volt cathode-return voltage should remain unchanged during this adjustment. It will not be necessary to have any input signal to the speech amplifier during the foregoing tests.

The last check to be made, assuming that the am-

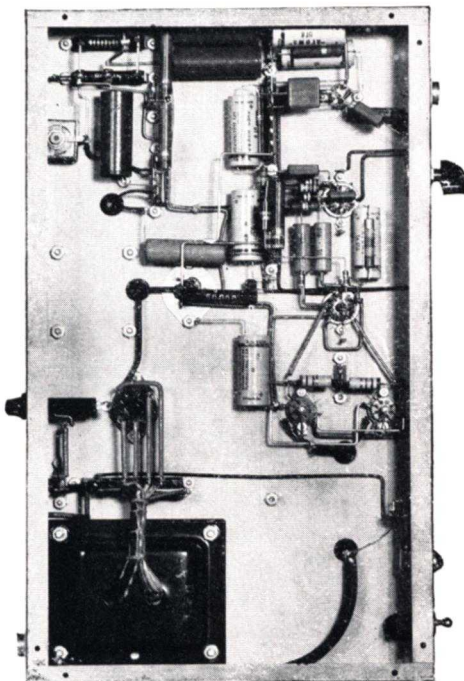

Fig. 4. Under-chassis View of the Restricted-range Speech Amplifier

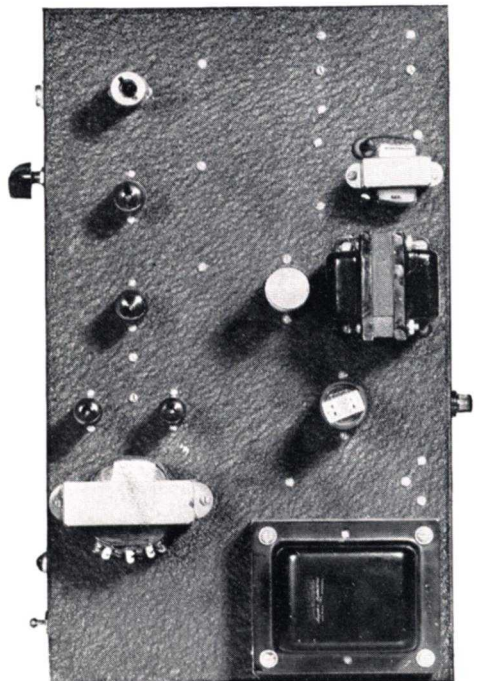

Fig. 5. Top View of the Restricted-range Speech Amplifier

plifier has been correctly wired and is operable, is to match the 6AQ5 tubes to their load. The amount of power that these tubes can deliver will depend to a great degree upon the output transformer. The selection of an output transformer will be governed primarily by the proposed application. It is recommended, however, that a transformer with a number of various impedances be used, so that minor changes in matching may be made.

It is further recommended that a transformer be purchased which has a generous power rating. For example, a 10 watt transformer will serve, but a 20 watt output transformer will permit more output to be achieved without distortion. The amplifier pictured uses a 10 watt output transformer. The highest output power which could be achieved without discernible distortion on an oscilloscope was 7.2 watts (measured output from the transformer). A second amplifier with an 18 watt output transformer permitted an output, under the same conditions, of 11.2 watts. In both cases the transformer was matched to the

output load impedance, which took the form of a resistor.

Therefore, procure a transformer which is capable of matching from an approximate impedance of 10,000 ohms (the plate-to-plate effective load resistance of the 6AQ5 tubes) to whatever class B grids you wish to drive. Or, you may wish to match 10,000 ohms to a 500 ohm line. In the latter case another transformer is required to match from the 500 ohm line to the modulator grids. If this system is used, approximately twice as much power is lost between the driver plates and the modulator grids as compared to the case where only one transformer is used. You may expect to get losses up to 3 db in each transformer. Three db is two-to-one in power.

Once the transformer is procured and the amplifier tested while driving the required load, it may be advisable to make small changes in the impedance ratio between driver and modulator to ensure that you have an impedance match which will give maximum power transfer with minimum distortion.

TRICKS AND TOPICS

How did you solve that last problem that almost had you stumped? Be it about tubes, antennas, circuits, etc., Lighthouse Larry would like to tell the rest of the hams about it. Send it in! For each "trick" published you win \$10 worth of G-E Electronic Tubes. No entries returned. Mark your letter "Entry for Tricks and Topics" and send to Lighthouse Larry, Tube Division, Bldg. 269, General Electric Company, Schenectady, New York, or in Canada, to Canadian General Electric Company, Ltd., Toronto, Ontario.

CLEANING OLD SOCKETS

The experimenter who is perpetually using the same old ceramic tube sockets over and over again finds that eventually the sockets become dirty with surplus rosin and dirt. These sockets may be cleaned to look like new in the following manner.

Procure a small bottle—a pint jar is about the right size—and fill half of it with sand or fine gravel. Put in the socket and fill the remainder of the jar with paint remover. (Alcohol, turpentine or acetone are equally good—Ed's note.) Shake the jar vigorously for a minute or so. When the socket is removed it will be perfectly clean. Be careful that you do not try to clean sockets that are made of a material which is soluble in the solution you use.—KL7HI.

REFINISHING PANELS

Rack and panel transmitters are good looking when new, but the black or gray crackle finish eventually gets dull and shabby in appearance. It is generally difficult to completely repaint a panel and still maintain the crackle appearance, unless a professional does the job.

However, here is an easy way to repaint panels. The crackle finish will still be present when the job is complete.

First dust the panel thoroughly with a lintless cloth. Next, apply a coat of black (or gray) enamel

with a brush. Use good quality enamel. Apply only a thick enough coat to ensure that the panel is covered. Brush off any excess paint.

Let the enamel dry for 10 minutes, then make a wad of cloth and wipe over the panel in long sweeps. Turn the cloth wad to a clean portion before each stroke, so that you continue to remove the enamel. After all excess enamel has been removed, procure a clean cloth and rub the panel in short circular strokes, applying only light pressures. This gives the panel its finish. (A sponge will not work well.) Finally, let the panel dry in a dust-free room.—W1GVY

(Ed's note—This same idea can also be carried out by those with spray guns. Spray the panel with a very thin coat of flat black (or gray) paint and let dry. Do not rub. The result will be a completely refinished crackle panel.)

JOINT UNSOLDERING

Often it is necessary to unsolder a well-made joint and remove parts without damaging them. If the joint has been made using the sound practice of getting a good mechanical connection before applying the solder, the removal of a part is difficult. A good clean job can be made of this removal by using a well-tinned, hot soldering iron which is held on the joint in such a way that the force of gravity will cause the molten solder to run off the joint onto the tinned surface of the iron where it can be wiped off with a rag. In this way, most of the solder can be removed from the joint. It is then possible to grab the end of the wire with long-nose pliers and carefully unwind it from the terminal with an action similar to that used in opening a sardine can. The end is then straightened, and it can be slipped out of the hole in the terminal when heated once more with the iron. In this way, the lead length on the used part is preserved. The terminal is also left clean, ready for the new part, free of the danger of shorts due to surplus solder.—W1RQC

QUESTIONS AND ANSWERS



Do you have any questions about tubes or tube circuits that are of general interest? For each question published you will receive \$10 worth of G-E Electronic tubes. Mark your letter "Entry for Questions and Answers" and send to Lighthouse Larry, Tube Division, Bldg. 269, General Electric Company, Schenectady, New York, or in Canada to Canadian General Electric Company, Ltd., Toronto, Ontario.

SUFFIX "W"

Question: I noticed in a recent receiving tube list that several tubes had the letter "W" added at the end of their regular number (6SN7W for example) and that the price of these tubes was greater than the regular tube price. What is the difference between the tubes? Are they useful for amateur service?—D. Ringle.

Answer: The regular and the "W" type tubes are identical electrically but the latter are much more rugged mechanically. These tubes must pass very severe mechanical tests as specified in the JAN specifications—for example, shock tests and vibration fatigue tests. The suffix W is used with only a few tube types.

The amateurs could certainly use these ruggedized tubes, but the question is whether it would be worthwhile to spend the extra money. If the tubes were used in an application where shock and vibration were important, such as a mobile installation, then their use could certainly be considered.—Lighthouse Larry.

C-R TUBE NUMBERING

Question: I understand that the type designations for cathode ray tubes have a special meaning concerning the characteristics of the tube. How should these designations be interpreted?—Walter H. Bryan.

Answer: There is a definite system which is followed when giving numbers to cathode ray tubes, although the number itself may not give the user too much information. For example, consider the number 12KP4. The number 12 refers to the nominal size of the face of the tube, in inches. The letter K indicates the sequence in which the tube was registered with RMA, and in this case shows that the 12KP4 was the eleventh twelve-inch tube registered.

The letter K also indicates that the 12KP4 is a design different from that of the 12JP4, for example, or from that of any other twelve-inch tube. However, there is no relation between the K in the 12KP4 number and a K that may appear in some other number.

The final letter-number group, P4 in this case, indicates the type of screen characteristic. Actually it means the fourth phosphor registered. All cathode ray tube numbers with the same phosphor number will have the same type of screen, both in color and persistence.—Lighthouse Larry.

GLASS TUBE NUMBERS

Question: What is the difference between G, GT and GT/G tubes having the same number? Are these tubes interchangeable?—H. Farber.

Answer: The suffix G used after a tube number indicates that it is a glass tube. For example, the 6K7-G is the glass version of the 6K7 metal tube. Tubes with the G suffix have large glass bulbs. In the case of the 6K7-G, the tube is $4\frac{1}{2}$ inches high and $1\frac{5}{16}$ inches in diameter.

The 6K7-GT is also a glass tube using a smaller glass bulb. This particular tube is $3\frac{5}{16}$ inches high and $1\frac{5}{16}$ inches in diameter. The 6K7-GT/G is a tube which is identical to the 6K7-GT. The extra G has been added to the tube type number to indicate that the tube is interchangeable with the 6K7-G. Other than a difference in marking, they are the same tube.

The 6K7-G and the 6K7-GT, while different in size, are interchangeable. They are slightly different electrically. For example, the interelectrode capacitances are not exactly the same. However, they both carry the same ratings insofar as operating conditions are concerned.

The remarks made above concerning the interchangeability of the 6K7-G, the 6K7-GT and the 6K7-GT/G also hold for any other tube types with the same suffixes.—Lighthouse Larry.

BATTERY-OPERATED TUBES

Question: Why are battery-operated tubes more microphonic than other types? What is the best cure for this?—R. Britton.

Answer: Battery-type tubes have a low-voltage, low-power filament. This means that the filament wire itself is very small. For this reason the filament is much more liable to move, when the tube is subjected to shock, than the heavier filament and cathode structures found in the higher-voltage tubes.

Inasmuch as this microphonism is inherent in the battery-type tubes, the only cure is to make sure that the tube is not subjected to shocks of any sort.—Lighthouse Larry.



Sweeping the Spectrum



The questionnaires sent out with the May-June, 1949 *Ham News* have elicited a very nice response, due to your generosity in sparing the time to fill them out so completely. It will take some time before the results can be thoroughly tabulated, but you may expect to see the results in this column at some time in the future. If you have not yet sent in your questionnaire, there is still time. Shoot it along.

❖ ❖ ❖

Speaking of questionnaires, many of you who sent them in added requests for back copies of the *Ham News*, or asked questions of one sort or another. Due to the automatic manner in which these questionnaires are being handled, it would not be feasible to sort through a few thousand of them to locate those few which contained extra requests. Ergo, if you were one of those who did ask a question or make a request directly on the questionnaire, let me have it again.

❖ ❖ ❖

Are the pieces of equipment described in the *Ham News* just pretty show pieces, or do they actually work? This question came from an amateur recently. It also came as quite a shock to me. I still haven't learned what prompted his question. Perhaps he had built one of the *Ham News* units and had bad luck with it. Or, and I prefer this answer, he hadn't built any of the *Ham News* units, so that he was in no position to judge their merit.

Rather than leave you in suspense, here is the low-down. After the design has been decided upon, the unit is constructed in the laboratory. It is then subjected to a series of tests to determine if it will operate properly. If something is lacking in the performance of the unit it is redesigned and rebuilt. Many units have been built which will never be described in *Ham News* because 1) they were too critical of adjustment, or 2) required special hand-

made parts which the average amateur could not make, or 3) they just would not work.

If there is any doubt that an amateur might find it difficult to construct a certain unit, then two of these are constructed. The second unit may have its components arranged in a different manner, so that the wiring will not be identical to that in the first unit. If both units perform in the same way, then the chances are that the circuit and mechanical construction is sound, and that most amateurs will find no difficulty in constructing a similar unit.

Therefore, when you see some piece of equipment described in the *Ham News*, you are sure that it has been built carefully, thoroughly tested and debugged, and if it is a transmitting unit, given complete on-the-air tests.

Of course, none of the above holds for "Tricks and Topics." These submitted ideas are published if they seem to be clever and new, but no attempt is made to thoroughly check each one.

❖ ❖ ❖

There is an old saying "there is nothing new under the sun." I had to prove it the hard way. When writing the "Sweeping the Spectrum" column for the March-April, 1949 *Ham News* I came to the last couple of inches in the column and decided I'd use the space to tell you about a little trick I'm fond of. You recall—the nuts and washers on an icepick stunt. You should have seen the letters that came back at me on that one. Most of them just plainly stated that they had been using that idea for years.

However, W8HAR stated that he was glad to see that "great minds run in the same channel." Thanks for the kind words, Bernie. Of course, even Bernie had an idea to go me one better. So, expect to see (in a future "Tricks and Topics") a number of ideas on how to get a nut on a screw which is in one of those "hard-to-get-at" places. And don't expect to get too many more of my ideas. I surrender, fellows!

— *Lighthouse Larry*

TECHNICAL INFORMATION

12AX7

GENERAL DESCRIPTION

Principal Application: The 12AX7 is a nine-pin miniature tube consisting of two triode sections each having an amplification factor of 100 and an individual cathode connection. A center-tapped 12.6-volt 150-milliamper heater is provided, which may be con-

nected for either series or parallel operation. This tube may be used in resistance-coupled audio-frequency amplifiers, phase inverters, multivibrators and numerous industrial-control circuits.

Cathodes	Coated Unipotential
	Series Parallel
Heater Voltage (A-C or D-C)	12.6 6.3 Volts
Heater Current	0.15 0.3 Ampere
Envelope	T-6½ Glass
Base:	E9-1 Small Glass-Button 9-Pin

Mounting Position	Any
Direct Interelectrode Capacitances #	
	Section No. 1 Section No. 2
Grid to Plate	1.7 1.7 μμf
Input	1.6 1.6 μμf
Output	0.46 0.34 μμf

Without external shield.

MAXIMUM RATINGS

	Design Center	Absolute	
Plate Voltage	300	330	Volts
Plate Dissipation (Each Section)	1.0	1.1	Watts
Grid Voltage			
Negative Bias Value	50	55	Volts
Positive Bias Value	0	0	Volts
Peak Heater-Cathode Voltage	180	198	Volts

CHARACTERISTICS AND TYPICAL OPERATION

CLASS A₁ AMPLIFIER (Each Triode Section)

Plate Voltage	100	250	Volts
Grid Voltage	-1	-2	Volts
Amplification Factor	100	100	
Plate Resistance	80000	62500	Ohms
Transconductance	1250	1600	Micromhos
Plate Current	0.5	1.2	Milliamperes

PHYSICAL DIMENSIONS

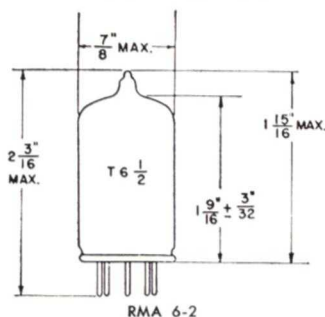

TERMINAL CONNECTIONS

- Pin 1—Plate (Section Number 2)
- Pin 2—Grid (Section Number 2)
- Pin 3—Cathode (Section Number 2)
- Pin 4—Heater
- Pin 5—Heater
- Pin 6—Plate (Section Number 1)
- Pin 7—Grid (Section Number 1)
- Pin 8—Cathode (Section Number 1)
- Pin 9—Heater Center-Tap

BASING DIAGRAM

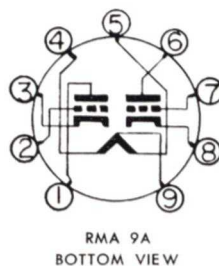

If You Didn't Get This From My Site,
Then It Was Stolen From...

www.SteamPoweredRadio.Com

ELECTRONICS DEPARTMENT

GENERAL ELECTRIC

SCHENECTADY, N. Y.

(In Canada, Canadian General Electric Company, Ltd., Toronto, Ont.)

Printed in U.S.A.