

**TECHNICAL MANUAL**  
**MW-5B**  
**AM BROADCAST TRANSMITTER**  
**888-2109-014**

994 8622 001

**HARRIS**



T.M. No. 888-2109-014  
© Copyright Harris Corporation  
1985  
All rights reserved

Printed : January 23, 1985

## **Returns And Exchanges**

Damaged or undamaged equipment should not be returned unless written approval and a Return Authorization is received from HARRIS CORPORATION, Broadcast Systems Division. Special shipping instructions and coding will be provided to assure proper handling. Complete details regarding circumstances and reasons for return are to be included in the request for return. Custom equipment or special order equipment is not returnable. In those instances where return or exchange of equipment is at the request of the customer, or convenience of the customer, a restocking fee will be charged. All returns will be sent freight prepaid and properly insured by the customer. When communicating with HARRIS CORPORATION, Broadcast Systems Division, specify the HARRIS Order Number or Invoice Number.

## **Unpacking**

Carefully unpack the equipment and preform a visual inspection to determine that no apparent damage was incurred during shipment. Retain the shipping materials until it has been determined that all received equipment is not damaged. Locate and retain all PACKING CHECK LISTs. Use the PACKING CHECK LIST to help locate and identify any components or assemblies which are removed for shipping and must be reinstalled. Also remove any shipping supports, straps, and packing materials prior to initial turn on.

## **Technical Assistance**

HARRIS Technical and Troubleshooting assistance is available from HARRIS Field Service during normal business hours (8:00 AM - 5:00 PM Central Time). Emergency service is available 24 hours a day. Telephone 217/222-8200 to contact the Field Service Department or address correspondence to Field Service Department, HARRIS CORPORATION, Broadcast Systems Division, P.O. Box 4290, Quincy, Illinois 62305-4290, USA. The HARRIS factory may also be contacted through a FAX facility (217/221-7096).

## **Replaceable Parts Service**

Replacement parts are available 24 hours a day, seven days a week from the HARRIS Service Parts Department. Telephone 217/222-8200 to contact the service parts department or address correspondence to Service Parts Department, HARRIS CORPORATION, Broadcast Systems Division, P.O. Box 4290, Quincy, Illinois 62305-4290, USA. The HARRIS factory may also be contacted through a FAX facility (217/221-7096).

### **NOTE**

The # symbol used in the parts list means used with (e.g. #C001 = used with C001).

## Guide to Using Harris Parts List Information

The Harris Replaceable Parts List Index portrays a tree structure with the major items being leftmost in the index. The example below shows the Transmitter as the highest item in the tree structure. If you were to look at the bill of materials table for the Transmitter you would find the Control Cabinet, the PA Cabinet, and the Output Cabinet. In the Replaceable Parts List Index the Control Cabinet, PA Cabinet, and Output Cabinet show up one indentation level below the Transmitter and implies that they are used in the Transmitter. The Controller Board is indented one level below the Control Cabinet so it will show up in the bill of material for the Control Cabinet. The tree structure of this same index is shown to the right of the table and shows indentation level versus tree structure level.

Example of Replaceable Parts List Index and equivalent tree structure:

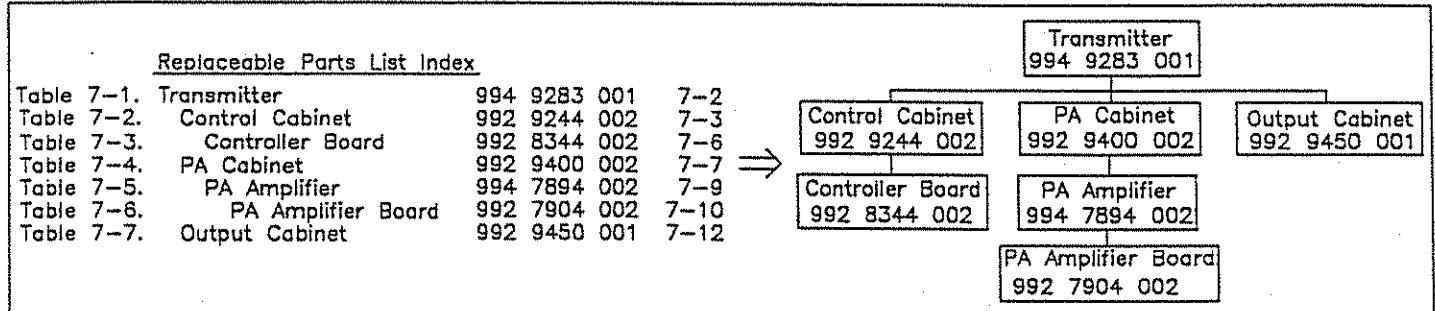

The part number of the item is shown to the right of the description as is the page in the manual where the bill for that part number starts.

Inside the actual tables, four main headings are used:

**Table #-#. ITEM NAME - HARRIS PART NUMBER** - this line gives the information that corresponds to the Replaceable Parts List Index entry;

**HARRIS P/N** column gives the ten digit Harris part number (usually in ascending order);

**DESCRIPTION** column gives a 25 character or less description of the part number;

**REF. SYMBOLS/EXPLANATIONS** column 1) gives the reference designators for the item (i.e., C001, R102, etc.) that corresponds to the number found in the schematics (C001 in a bill of material is equivalent to C1 on the schematic) or 2) gives added information or further explanation (i.e., "Used for 208V operation only," or "Used for HT 10LS only," etc.).

Inside the individual tables some standard conventions are used:

A # symbol in front of a component such as #C001 under the REF. SYMBOLS/EXPLANATIONS column means that this item is used on or with C001 and is not the actual part number for C001.

In the ten digit part numbers, if the last three numbers are 000, the item is a part that Harris has purchased and has not manufactured or modified. If the last three numbers are other than 000, the item is either manufactured by Harris or is purchased from a vendor and modified for use in the Harris product.

The first three digits of the ten digit part number tell which family the part number belongs to - for example, all electrolytic (can) capacitors will be in the same family (524 xxxx 000). If an electrolytic (can) capacitor is found to have a 9xx xxxx xxx part number (a number outside of the normal family of numbers), it has probably been modified in some manner at the Harris factory and will therefore show up farther down into the individual parts list (because each table is normally sorted in ascending order). Most Harris made or modified assemblies will have 9xx xxxx xxx numbers associated with them.

The term "SEE HIGHER LEVEL BILL" in the description column implies that the reference designated part number will show up in a bill that is higher in the tree structure. This is often the case for components that may be frequency determinant or voltage determinant and are called out in a higher level bill structure that is more customer dependent than the bill at a lower level.



Broodcast Systems Division  
P.O. Box 4290, QUINCY, IL 62305

# PARTS ORDER FORM

HARRIS PHONE: 217-222-8200  
HARRIS FAX: 217-221-7096

## BILLING INFORMATION

CUSTOMER NAME: \_\_\_\_\_  
 ADDRESS: \_\_\_\_\_  
 \_\_\_\_\_  
 \_\_\_\_\_  
 \_\_\_\_\_

## SHIPPING INFORMATION

SHIP TO: \_\_\_\_\_  
 (if different from billing information)  
 ADDRESS: \_\_\_\_\_  
 \_\_\_\_\_  
 \_\_\_\_\_

TELEPHONE NUMBER: \_\_\_\_\_  
 FAX NUMBER: \_\_\_\_\_

SHIPPING METHOD PREFERRED: \_\_\_\_\_

**GUIDE FOR ORDERING PARTS**

Please use the following parts order form, filling in as much information as possible. The complete information will allow double checking the part number for correctness or locating a substitute if the part is not available.  
 The equipment name, part number, and serial number will be found on the metal ID plate on the back of the unit. The serial number MUST be included for any parts ordered under warranty.  
 Describe the part using the description in the parts list if possible. Include the schematic information, schematic number, or number of next higher assembly. The next higher assembly is usually a 992-xxx-00x type.

FREQUENCY (if required): \_\_\_\_\_  
 EQUIPMENT NAME: \_\_\_\_\_  
 EQUIPMENT PART NUMBER: \_\_\_\_\_  
 EQUIPMENT SERIAL NUMBER: \_\_\_\_\_

ITEM #	QTY ORD	HARRIS PART NUMBER	DESCRIPTION OF PART (PART'S NAME, DESCRIPTION, SPECIFICATION FROM PARTS LIST IF AVAILABLE)	SCHEMATIC REFERENCE REFERENCE NAME (e.g. C001, R100, etc)	ITEM USED ON (NEXT HIGHER ASSEMBLY IF KNOWN) (e.g. C001 used on 992 8025 001, SCHEMATIC 839 8099 991)	COMMENTS



MANUAL REVISION HISTORY  
MW-5B AM BROADCAST TRANSMITTER  
888-2109-xxx

<u>REV. #</u>	<u>DATE</u>	<u>ECN</u>	<u>PAGES AFFECTED</u>
011	06-06-84	29067	Replaced the following pages: Title Page 1-6, 5-13, 5-15, 5-16, 5-28, 5-29, 5-30, 5-31, 5-32 Added the following page: Manual Revision History page
012	07-31-84	29106	Replaced the following pages: Title Page, Manual Revision History Page, 7-32
013	10-18-84	29122	Replaced the following pages: Title Page, Manual Revision History Page 7-10, 8-11/8-12
014	01-23-85	27944	Replaced the following pages: Title Page, Manual Revision History Page, 7-29

888-2109-014

WARNING

THE CURRENTS AND VOLTAGES IN THIS EQUIPMENT ARE DANGEROUS.  
PERSONNEL MUST AT ALL TIMES OBSERVE SAFETY REGULATIONS.

This manual is intended as a general guide for trained and qualified personnel who are aware of the dangers inherent in handling potentially hazardous electrical/electronic circuits. It is not intended to contain a complete statement of all safety precautions which should be observed by personnel in using this or other electronic equipment.

The installation, operation, maintenance and service of this equipment involves risks both to personnel and equipment, and must be performed only by qualified personnel exercising due care. HARRIS CORPORATION shall not be responsible for injury or damage resulting from improper procedures or from the use of improperly trained or inexperienced personnel performing such tasks.

During installation and operation of this equipment, local building codes and fire protection standards must be observed. The following National Fire Protection Association (NFPA) standards are recommended as references:

- Automatic Fire Detectors, No. 72E
- Installation, Maintenance, and Use of Portable Fire Extinguishers, No. 10
- Halogenated Fire Extinguishing Agent Systems, No. 12A

WARNING

ALWAYS DISCONNECT POWER BEFORE OPENING COVERS, DOORS, ENCLOSURES, GATES, PANELS OR SHIELDS. ALWAYS USE GROUNDING STICKS AND SHORT OUT HIGH VOLTAGE POINTS BEFORE SERVICING. NEVER MAKE INTERNAL ADJUSTMENTS, PERFORM MAINTENANCE OR SERVICE WHEN ALONE OR WHEN FATIGUED.

Do not remove, short-circuit or tamper with interlock switches on access covers, doors, enclosures, gates, panels or shields. Keep away from live circuits, know your equipment and don't take chances.

WARNING

IN CASE OF EMERGENCY ENSURE THAT POWER HAS BEEN DISCONNECTED.

WARNING

IF OIL FILLED OR ELECTROLYTIC CAPACITORS ARE UTILIZED IN YOUR EQUIPMENT, AND IF A LEAK OR BULGE IS APPARENT ON THE CAPACITOR CASE WHEN THE UNIT IS OPENED FOR SERVICE OR MAINTENANCE, ALLOW THE UNIT TO COOL DOWN BEFORE ATTEMPTING TO REMOVE THE DEFECTIVE CAPACITOR. DO NOT ATTEMPT TO SERVICE A DEFECTIVE CAPACITOR WHILE IT IS HOT DUE TO THE POSSIBILITY OF A CASE RUPTURE AND SUBSEQUENT INJURY.

## TREATMENT OF ELECTRICAL SHOCK

1. IF VICTIM IS NOT RESPONSIVE FOLLOW THE A-B-C'S OF BASIC LIFE SUPPORT.

PLACE VICTIM FLAT ON HIS BACK ON A HARD SURFACE

### **(A) AIRWAY**

IF UNCONSCIOUS.  
OPEN AIRWAY

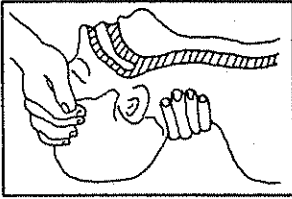

LIFT UP NECK  
PUSH FOREHEAD BACK  
CLEAR OUT MOUTH IF NECESSARY  
OBSERVE FOR BREATHING

CHECK  
CAROTID PULSE

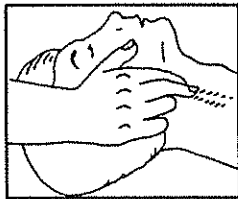

IF PULSE ABSENT,  
BEGIN ARTIFICIAL  
CIRCULATION

### **(B) BREATHING**

IF NOT BREATHING.  
BEGIN ARTIFICIAL BREATHING

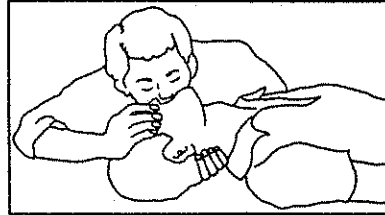

TILT HEAD  
PINCH NOSTRILS  
MAKE AIRTIGHT SEAL  
4 QUICK FULL BREATHS  
REMEMBER MOUTH TO MOUTH  
RESUSCITATION MUST BE  
COMMENCED AS SOON AS POSSIBLE

### **(C) CIRCULATION**

DEPRESS STERNUM 1 1/2 TO 2 INCHES

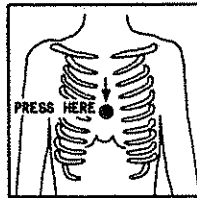

APPROX. RATE  
OF COMPRESSIONS { ONE RESCUER  
--80 PER MINUTE { 15 COMPRESSIONS  
2 QUICK BREATHS

APPROX. RATE  
OF COMPRESSIONS { TWO RESCUERS  
--60 PER MINUTE { 5 COMPRESSIONS  
1 BREATH

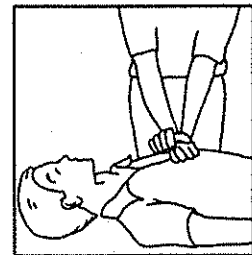

NOTE: DO NOT INTERRUPT RHYTHM OF COMPRESSIONS  
WHEN SECOND PERSON IS GIVING BREATH

CALL FOR MEDICAL ASSISTANCE AS SOON AS POSSIBLE.

2. IF VICTIM IS RESPONSIVE.

- A. KEEP THEM WARM
- B. KEEP THEM AS QUIET AS POSSIBLE
- C. LOOSEN THEIR CLOTHING
- D. A RECLINING POSITION IS RECOMMENDED

## FIRST-AID

Personnel engaged in the installation, operation, maintenance or servicing of this equipment are urged to become familiar with first-aid theory and practices. The following information is not intended to be complete first-aid procedures, it is brief and is only to be used as a reference. It is the duty of all personnel using the equipment to be prepared to give adequate Emergency First Aid and thereby prevent avoidable loss of life.

### Treatment of Electrical Burns

1. Extensive burned and broken skin
  - a. Cover area with clean sheet or cloth. (Cleanest available cloth article.)
  - b. Do not break blisters, remove tissue, remove adhered particles of clothing, or apply any salve or ointment.
  - c. Treat victim for shock as required.
  - d. Arrange transportation to a hospital as quickly as possible.
  - e. If arms or legs are affected keep them elevated.

#### NOTE

If medical help will not be available within an hour and the victim is conscious and not vomiting, give him a weak solution of salt and soda: 1 level teaspoonful of salt and 1/2 level teaspoonful of baking soda to each quart of water (neither hot or cold). Allow victim to sip slowly about 4 ounces (a half of glass) over a period of 15 minutes. Discontinue fluid if vomiting occurs. (Do not give alcohol.)

2. Less severe burns - (1st & 2nd degree)
  - a. Apply cool (not ice cold) compresses using the cleanest available cloth article.
  - b. Do not break blisters, remove tissue, remove adhered particles of clothing, or apply salve or ointment.
  - c. Apply clean dry dressing if necessary.
  - d. Treat victim for shock as required.
  - e. Arrange transportation to a hospital as quickly as possible.
  - f. If arms or legs are affected keep them elevated.

REFERENCE: ILLINOIS HEART ASSOCIATION

AMERICAN RED CROSS STANDARD FIRST AID AND PERSONAL SAFETY MANUAL  
(SECOND EDITION)

## TABLE OF CONTENTS

<u>Paragraph</u>		<u>Page</u>
SECTION I. GENERAL DESCRIPTION		
1-1.	Introduction .....	1-1
1-3.	Physical Description .....	1-1
1-10.	Functional Description .....	1-3
1-20.	Equipment Characteristics .....	1-7
1-21.	Electrical Characteristics .....	1-7
1-23.	Mechanical/Environmental Characteristics .....	1-7
SECTION II. INSTALLATION		
2-1.	Introduction .....	2-1
2-3.	Incoming Inspection and Unpacking .....	2-1
2-7.	Returns and Exchanges .....	2-1
2-9.	Installation .....	2-2
2-11.	Transmitter Installation .....	2-2
2-14.	Installation of Removed Components .....	2-2
2-17.	Installation of Variable Capacitor 1C14 .....	2-5
2-20.	4CX3000A Modulator Tube Installation .....	2-12
2-21.	3CX2500F3 Power Amplifier Tube Installation .....	2-12
2-22.	External Connections .....	2-12
2-24.	Primary Power .....	2-12
2-26.	RF Output .....	2-14
2-27.	Audio Input (Normally 600-Ohm Balanced) .....	2-14
2-28.	Modulation Monitor .....	2-14
2-29.	Frequency Monitor .....	2-14
2-30.	Transmitter Grounding Stud .....	2-14
2-31.	External Interlock .....	2-18
2-32.	Remote Control Connections .....	2-18
2-33.	Initial Pre Turn On Mechanical Checks .....	2-20
2-35.	Initial Pre Turn On Electrical Checks .....	2-21
2-37.	Primary Power Application .....	2-22
2-39.	Remote Meter Calibration .....	2-31
2-41.	Remote Plate Current Sample Adjustment .....	2-31
2-43.	Remote PA Plate Voltage Meter Sample Calibration .....	2-33
2-45.	Remote $E_p$ - $I_p$ Calibration .....	2-34
SECTION III. OPERATION		
3-1.	Introduction .....	3-1
3-3.	Controls and Indicators .....	3-1
3-5.	Operating Procedure .....	3-1
3-7.	Modulation Enhancer .....	3-24
SECTION IV. PRINCIPLES OF OPERATION		
4-1.	General .....	4-1
4-3.	Overall Functional Description .....	4-1
4-5.	RF Subsystem .....	4-1
4-7.	Audio Subsystem .....	4-1
4-11.	Control Subsystem .....	4-2
4-13.	Personnel and Equipment Protection Subsystem .....	4-2

TABLE OF CONTENTS (Continued)

<u>Paragraph</u>		<u>Page</u>
4-15.	Safety Interlock Circuit .....	4-2
4-17.	DC Overload .....	4-2
4-19.	Dissipation Overload .....	4-4
4-21.	Modulator Screen Overload .....	4-4
4-23.	VSWR Overload Circuit .....	4-4
4-25.	Step Start Overload .....	4-4
4-27.	Overload Counter and Turn Off Circuit .....	4-4
4-29.	Air Interlock Switch .....	4-4
4-31.	HV Transformer Fault .....	4-5
4-33.	Detailed Description of Circuits .....	4-5
4-34.	RF Subsystem .....	4-5
4-35.	Oscillator Module 1A2A1 .....	4-5
4-43.	IPA and RF Drivers, 1A2A3 .....	4-6
4-47.	Power Amplifier Grid Circuit .....	4-7
4-50.	Audio Subsystem .....	4-7
4-51.	Modulation Enhancer .....	4-7
4-54.	PDM and Audio Driver, 1A1 .....	4-8
4-55.	Principles of Pulse Duration Modulation .....	4-8
4-56.	PDM Board, 1A1A1 .....	4-8
4-62.	Audio Driver Board, 1A1A3 .....	4-11
4-65.	Modulator Tube Circuit .....	4-11
4-66.	Modulator Tube .....	4-11
4-67.	75 kHz Filter .....	4-11
4-68.	Damper Diode Assembly .....	4-11
4-69.	Audio Input, Dissipation Overload, and Feedback 1A1A2 .....	4-12
4-71.	Bessel Filter .....	4-12
4-72.	Dissipation Limiter .....	4-12
4-73.	Negative Feedback .....	4-12
4-74.	Variable Feedback .....	4-13
4-75.	Positive Feedback .....	4-13
4-76.	Flag and Overload 1A2A2 .....	4-13
4-77.	Arc Overloads .....	4-13
4-78.	VSWR Overload .....	4-13
4-79.	DC Overload .....	4-14
4-80.	Dissipation Limiter .....	4-14
4-81.	Modulator Screen Overload .....	4-14
4-82.	Overload Counter .....	4-14
4-84.	Remote PA Plate Voltage Metering Amplifier .....	4-15
4-85.	AC Control 1A4 .....	4-15
4-90.	High/Low Power Control .....	4-16
4-91.	Directional Coupler Board 1A8 .....	4-16
4-93.	High-Voltage Transformer Protection .....	4-16

SECTION V. MAINTENANCE

5-1.	Introduction .....	5-1
5-3.	Purpose .....	5-1
5-5.	Station Records .....	5-1

TABLE OF CONTENTS (Continued)

<u>Paragraph</u>		<u>Page</u>
5-7.	Transmitter Logbook .....	5-1
5-9.	Maintenance Logbook .....	5-1
5-11.	Safety Precautions .....	5-2
5-14.	Preventive Maintenance .....	5-2
5-16.	Blower Filter Cleaning .....	5-3
5-18.	Blower Cleaning .....	5-3
5-20.	Maintenance of Components .....	5-3
5-22.	Transistors .....	5-4
5-23.	Capacitors .....	5-4
5-24.	Fixed Resistors .....	5-4
5-25.	Variable Resistors .....	5-5
5-26.	Transformers .....	5-5
5-27.	Fuses .....	5-5
5-28.	Meters .....	5-6
5-29.	Relays .....	5-6
5-30.	Switches .....	5-6
5-31.	Indicators and Indicator Switches .....	5-7
5-32.	Printed-Circuit Boards .....	5-7
5-33.	Corrective Maintenance .....	5-8
5-35.	Alignment and Calibration .....	5-8
5-36.	Transmitter Alignment .....	5-8
5-50.	PA Tune Capacitor 1C14 .....	5-11
5-52.	3rd Harmonic Resonator Tuning .....	5-11
5-54.	Setting Output Network .....	5-11
5-68.	Oscillator, IPA, and RF Driver Alignment .....	5-24
5-70.	Oscillator Alignment .....	5-24
5-71.	IPA Tuning .....	5-27
5-72.	RF Driver Check .....	5-29
5-73.	Carrier Frequency Check .....	5-32
5-75.	Efficiency Tuning .....	5-32
5-77.	Overload Checks and Adjustments .....	5-32
5-85.	Air Pressure Switch Sensitivity .....	5-38
5-87.	Electrical Zero of Plate Voltage Meter .....	5-39
5-89.	Audio Input/PDM Control Feedback Board .....	5-40
5-91.	Audio Board Alignment .....	5-41
5-92.	Audio Board Adjustment .....	5-42
5-93.	Bessel Filter Adjustment .....	5-43
5-94.	Low-Frequency -3 dB Point Adjustment .....	5-43
5-95.	Distortion Minimization .....	5-43
 SECTION VI. TROUBLESHOOTING		
6-1.	General .....	6-1
6-4.	Technical Assistance .....	6-1
6-7.	Transmitter Totally Inoperative .....	6-2
6-8.	Transmitter Filament and Low Volts Fails to Stay On .....	6-2
6-9.	High Voltage On Function Inoperative .....	6-3
6-10.	High Voltage Immediately Shuts Down When Plate ON Pushbutton Switch Depressed .....	6-3

TABLE OF CONTENTS (Continued)

<u>Paragraph</u>		<u>Page</u>
6-11.	No RF Out with Grid Drive, Filaments, and HV Supply Normal .....	6-7
6-12.	Poor or No Modulation Capability .....	6-7
6-13.	Poor Performance .....	6-7
6-14.	Overload Shutdowns .....	6-9
6-15.	Modulation Enhancer Malfunction .....	6-10
6-17.	RF Oscillator Module 1A2A1 Malfunction .....	6-10
6-19.	PDM Module 1A1A1 Malfunction .....	6-10
6-21.	RF Driver 1A2A3 Malfunction .....	6-10
SECTION VII. PARTS LIST		
7-1.	Introduction .....	7-1
7-3.	Replaceable Parts Service .....	7-1
SECTION VIII. DIAGRAMS		
8-1.	Introduction .....	8-1
APPENDIX A. DATA		
A-1.	Introduction .....	A-2



LIST OF TABLES

<u>Table</u>	<u>Page</u>
1-1. Electrical Characteristics .....	1-8
1-2. Mechanical/Environmental Characteristics .....	1-9
3-1. External Meter and Control Panels 1A7 and 1A9, Controls and Indicators .....	3-3
3-2. Meter Panel 1A7 Controls .....	3-6
3-3. Meter Panel 1A9 and Directional Coupler 1A8 Controls .....	3-8
3-4. Carrier Tuning Controls and HV Protection Controls and Indicators .....	3-10
3-5. AC Power Panel 1A4 Controls and Indicators .....	3-12
3-6. Isolated Plate 1A3, Modulation Enhancer 1A1A4, and Fine Power Adjust, Controls and Indicators .....	3-15
3-7. PDM Chassis 1A1 and RF Driver and Overload 1A2, Controls and Indicators .....	3-18
3-8. PDM Chassis 1A1, Controls and Indicators .....	3-20
3-9. RF Driver and Overload 1A2, Controls and Indicators .....	3-23
5-1. PA Tune Capacitor 1C14 Values .....	5-12
6-1. Modulation Enhancer 1A1A4 Troubleshooting .....	6-11
6-2. RF Oscillator Module 1A2A1 Troubleshooting .....	6-12
6-3. PDM Module 1A1A1 Troubleshooting .....	6-15
6-4. RF Driver 1A2A3 Troubleshooting .....	6-16
7-1. Replaceable Parts List Index .....	7-2
7-2. Xmtr MW5B 5kW .....	7-3
7-3. MW5B (Basic) Xmtr .....	7-4
7-4. PDM-Chassis-1A1 .....	7-7
7-5. PDS PC Board .....	7-8
7-6. PC Bd Xfmrless and Input .....	7-9
7-7. Audio Driver .....	7-12
7-8. PC Assy ME1 .....	7-13
7-9. RF and Overload .....	7-14
7-10. Oscillator .....	7-15
7-11. RF Driver, 1A2A3 .....	7-17
7-12. RF Driver Module .....	7-18
7-13. Flag/Overload PC .....	7-19
7-14. PA Grid, Iso Plate .....	7-21
7-15. AC Power Panel, 1A4 .....	7-22
7-16. Relay Overload Board .....	7-23
7-17. Power Supply, 1A5 .....	7-24
7-18. Left Meter Panel 1A7 .....	7-25
7-19. Directional Coupler .....	7-26
7-20. Rt Mrt Panel .....	7-27
7-21. HV Rectifier .....	7-28
7-22. Mod Scr PS/Mod Mon .....	7-29
7-23. Meter Multiplier .....	7-30
7-24. Pwb, HV Protection MW5/10 .....	7-31

## LIST OF ILLUSTRATIONS

<u>Figure</u>	<u>Page</u>
1-1. MW-5B AM BROADCAST TRANSMITTER .....	1-2
1-2. MW-5B AM BROADCAST TRANSMITTER, Front View .....	1-4
1-3. MW-5B AM BROADCAST TRANSMITTER, Rear View .....	1-5
1-4. MW-5B AM BROADCAST TRANSMITTER, Simplified Block Diagram .....	1-6
2-1. Transmitter Outline Drawing .....	2-3
2-2. Transmitter Component Locations (Sheet 1 of 6) .....	2-6
2-2. Transmitter Component Locations (Sheet 2 of 6) .....	2-7
2-2. Transmitter Component Locations (Sheet 3 of 6) .....	2-8
2-2. Transmitter Component Locations (Sheet 4 of 6) .....	2-9
2-2. Transmitter Component Locations (Sheet 5 of 6) .....	2-10
2-2. Transmitter Component Locations (Sheet 6 of 6) .....	2-11
2-3. Transmitter Interconnection Diagram .....	2-13
2-4. HV Transformer Connections, Wiring Diagram (Sheet 1 of 2) .....	2-15
2-4. HV Transformer Connections, Wiring Diagram (Sheet 2 of 2) .....	2-16
2-5. Transmitter Connection Locations .....	2-17
2-6. Blower Belt Tension Adjustment .....	2-20
2-7. Typical Multimeter Indications .....	2-25
2-8. Power Amplifier Waveform .....	2-28
3-1. External Meter and Control Panels 1A7 and 1A9, Controls and Indicators .....	3-2
3-2. Meter Panel 1A7 Controls .....	3-5
3-3. Meter Panel 1A9 and Directional Coupler 1A8 Controls .....	3-7
3-4. Carrier Tuning Controls and HV Protection Controls and Indicators .....	3-9
3-5. AC Power Panel 1A4 Controls and Indicators .....	3-11
3-6. Isolated Plate 1A3, Modulation Enhancer 1A1A4, and Fine Power Adjust Controls and Indicators .....	3-14
3-7. PDM Chassis 1A1 and RF Driver and Overload 1A2 Controls and Indicators .....	3-17
3-8. PDM Chassis 1A1 Controls and Indicators .....	3-19
3-9. RF Driver and Overload 1A2 Controls and Indicators .....	3-21
4-1. MW-5B AM BROADCAST TRANSMITTER Overall Block Diagram .....	4-3
4-2. Pulse Duration Modulator, Simplified Diagram .....	4-8
4-3. PDM Waveforms .....	4-9
5-1. Set-Up for 1L12 Test .....	5-10
5-2. Set-Up for 1L9 Test .....	5-11
5-3. Setting 3rd Harmonic Resonator .....	5-13
5-4. Set Up for Output Network Test .....	5-15
5-5. Phase Shift Test .....	5-16
5-6. Ratio of Load Voltage to Plate Voltage Test .....	5-18
5-7. Rough Tune-Up Test Set-Up .....	5-20
5-8. Adjustment of Grid Efficiency Capacitor 1A3C2 .....	5-25
5-9. Correct Power Amplifier Waveform Requirements .....	5-33

LIST OF ILLUSTRATIONS (Continued)

<u>Figure</u>	<u>PAGE</u>
8-1. RF and Overload Assembly 1A2, Schematic .....	8-3
8-2. MW-5B AM BROADCAST TRANSMITTER, Overall Schematic .....	8-5
8-3. Modulation Enhancer 1A1A4, Schematic .....	8-7
8-4. PDM and Audio Driver 1A1, Schematic (Sheet 1) .....	8-9
8-4. PDM and Audio Driver 1A1, Schematic (Sheet 2) .....	8-11
8-5. MW-5B Transmitter Frequency Determining Components .....	8-13
8-6. MW-5B Transmitter Control Circuits, Schematic .....	8-15
8-7. High Voltage Protection Circuitry .....	8-17
8-8. Wire Running List (Sheet 1 of 9) .....	8-19
8-8. Wire Running List (Sheet 2 of 9) .....	8-21
8-8. Wire Running List (Sheet 3 of 9) .....	8-23
8-8. Wire Running List (Sheet 4 of 9) .....	8-25
8-8. Wire Running List (Sheet 5 of 9) .....	8-27
8-8. Wire Running List (Sheet 6 of 9) .....	8-29
8-8. Wire Running List (Sheet 7 of 9) .....	8-31
8-8. Wire Running List (Sheet 8 of 9) .....	8-33
8-8. Wire Running List (Sheet 9 of 9) .....	8-35
8-9. Wire Running List, PDM and Audio (Sheet 1 of 2) .....	8-37
8-9. Wire Running List, PDM and Audio (Sheet 2 of 2) .....	8-39
8-10. Wire Running List, Oscillator and RF Driver Cable (Sheet 1 of 2) .....	8-41
8-10. Wire Running List, Oscillator and RF Driver Cable (Sheet 2 of 2) .....	8-43
8-11. Wire Running List, Low Voltage and Modulator Bias .....	8-45
8-12. Wire Running List, 1A11 .....	8-47

## SECTION I

### GENERAL DESCRIPTION

#### 1-1. INTRODUCTION

1-2. This Technical Manual contains all information necessary to install, operate, maintain, and service the HARRIS MW-5B AM BROADCAST TRANSMITTER (refer to figure 1-1). The various sections in this Technical Manual provide the following types of information.

- a. SECTION I GENERAL DESCRIPTION, provides a description of the equipment, identifies the major components, lists operating parameters and specifications, and describes other pertinent features of the equipment.
- b. SECTION II INSTALLATION, provides information relative to incoming inspection, power requirements, input/output connections, and component mounting instructions.
- c. SECTION III OPERATION, provides identification and functions of panel or component mounted controls and indicators, along with information necessary to setup and operate the transmitter.
- d. SECTION IV PRINCIPLES OF OPERATION, provides descriptions of functional circuits within the transmitter, beginning with a general overall block diagram discussion and proceeding through detailed printed-circuit board discussion.
- e. SECTION V MAINTENANCE, provides information pertaining to preventive and corrective maintenance, along with applicable performance schedules.
- f. SECTION VI TROUBLESHOOTING, provides fault location guidance and troubleshooting procedures along with instructions for equipment servicing.
- g. SECTION VII PARTS LIST, provides information for ordering replacement electrical components and assemblies together with selected mechanical parts.
- h. SECTION VIII DIAGRAMS, provides block, logic, and schematic diagrams and other drawings necessary for maintaining the transmitter.
- i. SECTION IX APPENDIX, provides manufacturers data.

#### 1-3. PHYSICAL DESCRIPTION

1-4. The HARRIS MW-5B AM BROADCAST TRANSMITTER has no external components and is completely self-contained in one equipment cabinet. Access to all transmitter components, except the transmitter controls and meter panels,

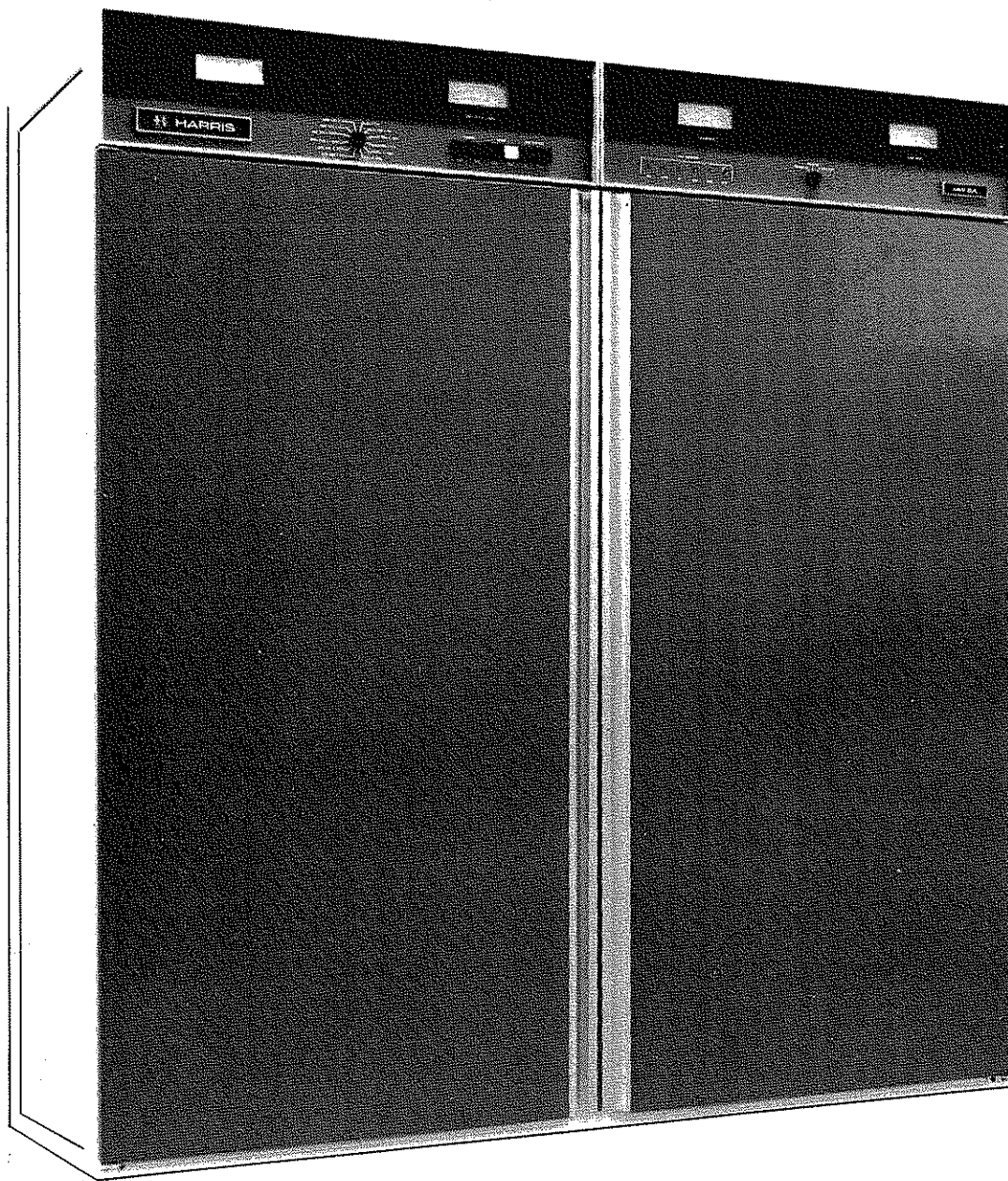

Figure 1-1. MW-5B AM BROADCAST TRANSMITTER

are achieved through the easily removed front and rear cabinet doors (figures 1-2 and 1-3). The swing-up transmitter control and meter panels are located at eye level on the front of the transmitter.

1-5. Opening the front left-hand door exposes the PDM Chassis, RF Driver Chassis, and the remote power control, which are mounted on swing-down panels on the internal control panel. The internal control panel also accommodates the vernier control used to regulate output power.

1-6. Opening the front right-hand door exposes the protective circuit breaker controls, and remote/local control switch. The protective circuit breakers, LOCAL/REMOTE CONTROL, FILAMENT HOURS meter, FILAMENT VOLTAGE adjustment, DC OVERLOAD adjustment, and MOD SCR VOLTAGE HI POWER and LOW POWER adjustments are all located on the lower right-hand panel.

1-7. Fault indicating devices for the Power Amplifier Driver modules are located in the RF Driver enclosure area.

1-8. The High-Voltage Transformer protection panel is located in the upper right-hand corner of the lower left-hand panel. The panel has access holes for test points, GAIN ADJUST potentiometer, and the HIGH VOLTAGE FAULT indicator (LED).

1-9. Filtered cooling air for the transmitter is provided by a blower and filter located at the bottom rear of the equipment cabinet. The air filter may be removed for cleaning during transmitter operation.

#### 1-10. FUNCTIONAL DESCRIPTION

1-11. The basic functional circuits in the HARRIS MW-5B AM BROADCAST TRANSMITTER consists of an Audio Section, RF Section, Control Section, and a Power Supply Section (figure 1-4).

1-12. The Audio Section includes a Modulation Enhancer, Audio Input Circuit (located on the PDM Control and Feedback Board), PDM Board Audio Driver, Modulator Tube, and the 75 kHz Filter. The PDM frequency is nominally 75 kHz, but may actually be several kHz above or below this value.

1-13. The RF Section includes a Crystal Oscillator, Intermediate Power Amplifier Module, four RF Driver Modules, and the PA Tube (3CX2500F3).

1-14. The Control Section includes power, personnel safety, and transmitter control circuits.

1-15. The Power Supply Section consists of a High-Voltage Power Supply, a 60-volt supply, a 120-volt supply, and a 30-volt supply.

1-16. The audio input to the transmitter is applied through the Modulation Enhancer, through a pad and balanced-to-unbalanced transformer, and the audio then pulse-width modulates a 75 kHz signal which is again amplified to drive the grid of the Modulator Tube.

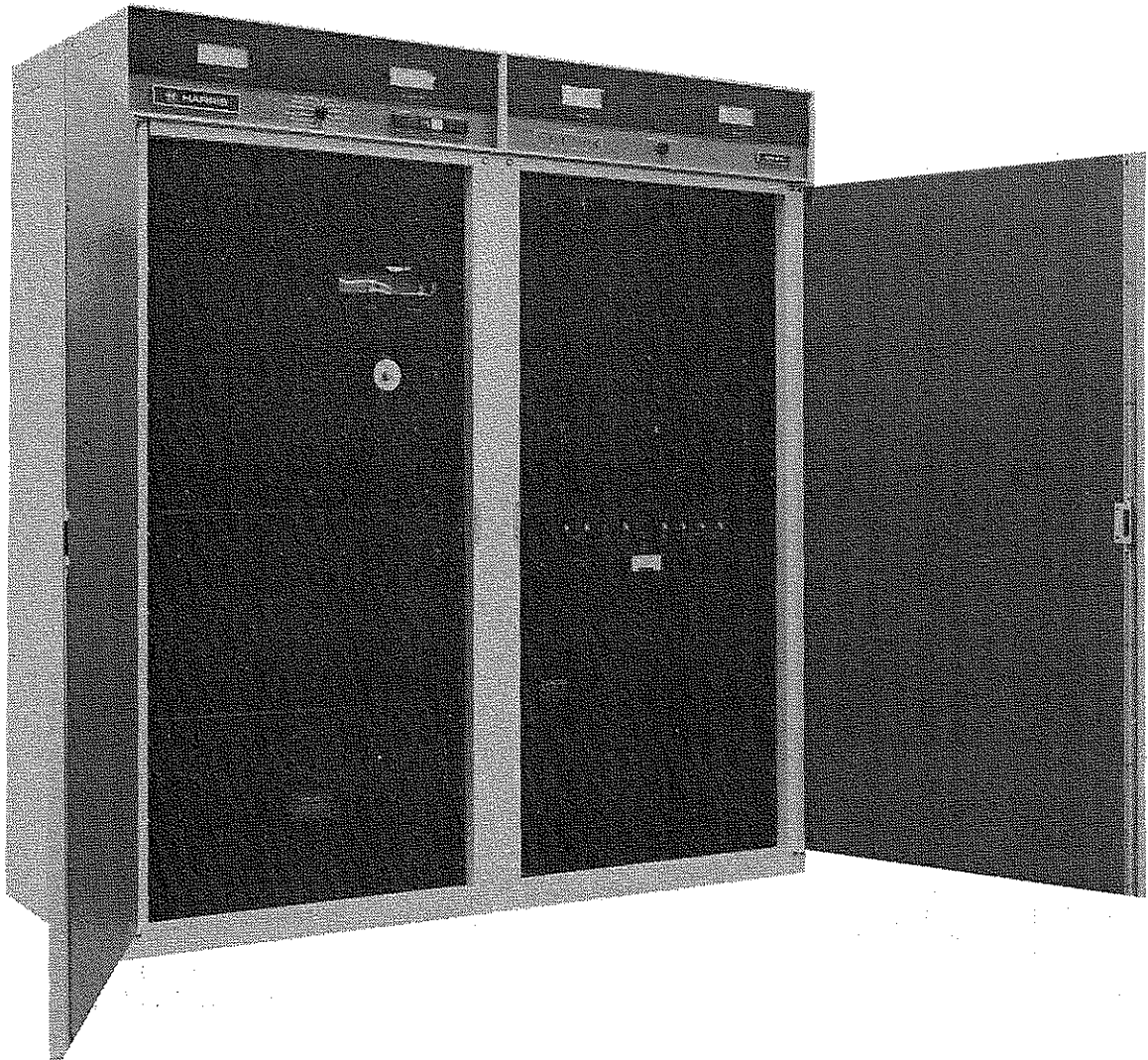

Figure 1-2. MW-5B AM BROADCAST TRANSMITTER, Front View

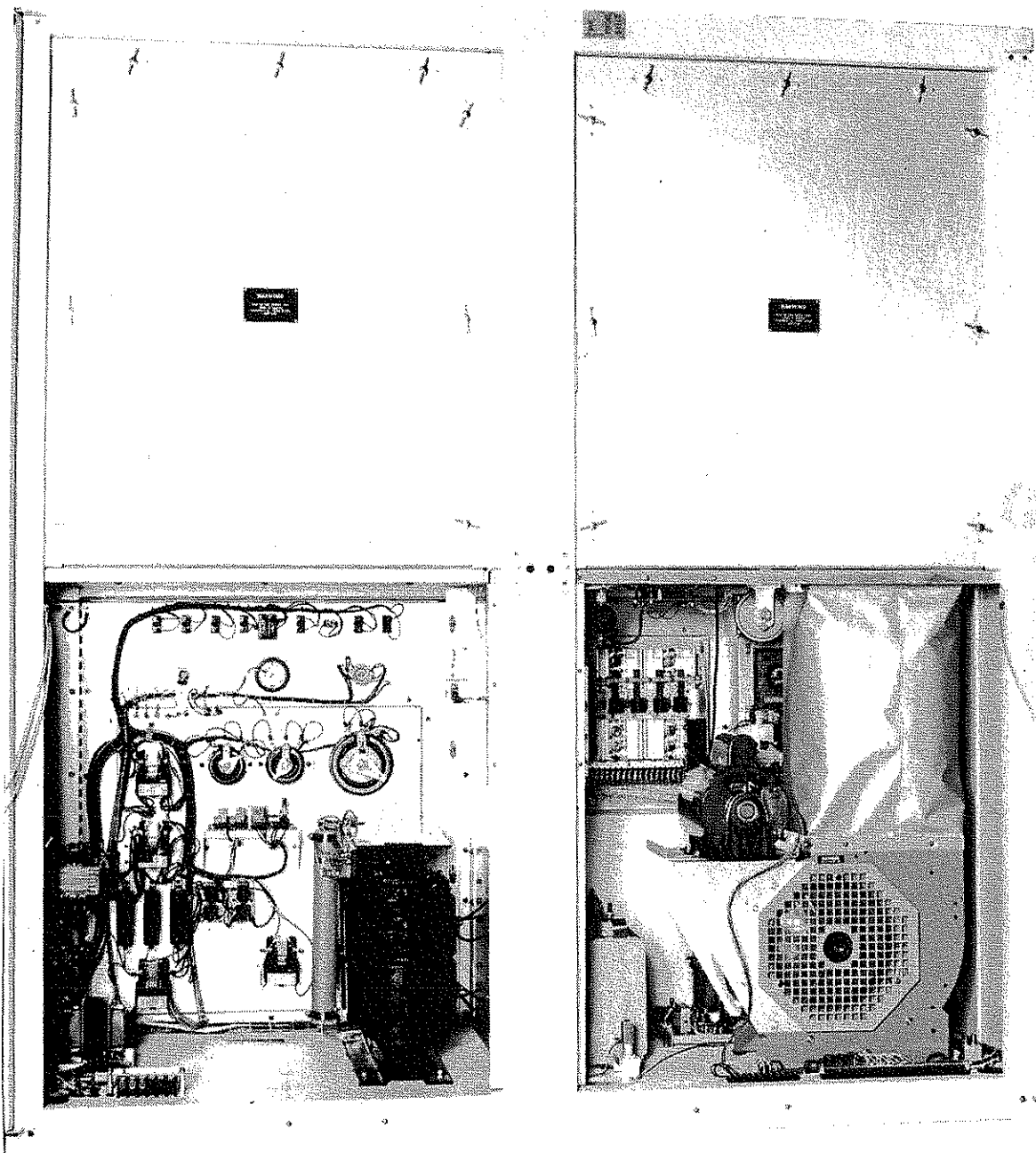

Figure 1-3. MW-5B AM BROADCAST TRANSMITTER, Rear View

888-2109-010

1-5



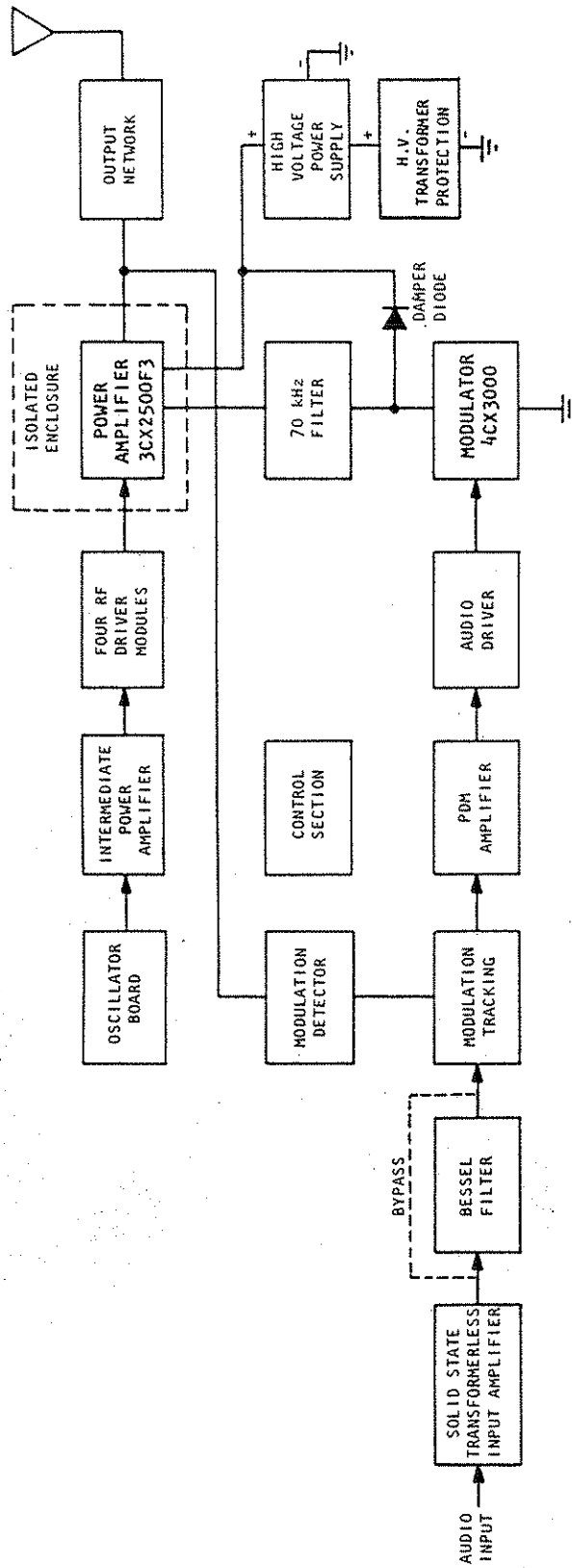

Figure 1-4. MW-5B AM BROADCAST TRANSMITTER Simplified Block Diagram

1-17. The oscillator in the RF Section produces an output which is twice or four times that of the carrier frequency, depending upon which is more stable with respect to temperature. This output is divided by two or four to reach the carrier frequency and amplified to drive the Intermediate Power Amplifier (IPA). The IPA is a class D amplifier which drives the RF Driver Module.

1-18. The four RF Driver Modules are identical with the IPA and are interchangeable with the IPA. The modules function as push-pull, class D amplifiers with outputs that drive the grid of the PA tube. The transmitter Output Network provides 225 degrees of phase-shift between the PA Tube and the load.

1-19. The power supplies in the HARRIS MW-5B AM BROADCAST TRANSMITTER are protected by circuit breakers which can be reset from the AC Power Panel. The high-voltage transformer is also protected against gross phase imbalance by the High-Voltage Protection circuitry. Other overload circuits are provided for transmitter fault protection.

1-20. EQUIPMENT CHARACTERISTICS

1-21. ELECTRICAL CHARACTERISTICS

1-22. Table 1-1 lists the electrical operating characteristics of the MW-5B AM BROADCAST TRANSMITTER.

1-23. MECHANICAL/ENVIRONMENTAL CHARACTERISTICS

1-24. Table 1-2 lists the mechanical and environmental characteristics of the MW-5B AM BROADCAST TRANSMITTER.

NOTE

Specifications subject to change without notice.

Table 1-1. Electrical Characteristics

FUNCTION	CHARACTERISTIC
Power Input	208/230 Vac, 60 Hz closed Delta or 380 Vac, 50 Hz Wye.
Power Consumption	9.4 kVA at 5000 watts carrier and no modulation. 13.0 kVA at 5000 watts carrier and 100% modulation.
Audio Input	10 dBm <u>+2</u> dB, 600/150 ohms balanced.
Audio Frequency Response	<u>+1</u> dB from 20 to 10,000 Hz at 95% modulation.
Audio Frequency Distortion	Less than 2% at 20 to 10,000 Hz, 95% modulation.
Power Output	Rated 5000 watts. Capable 5600 watts. Power reduction to 1000 watts.
Spurious Output	Meets or exceeds FCC and CCIR requirements.
RF Frequency Range	535 kHz to 1605 kHz.
RF Output Impedance	50/300 ohms, as specified.
RF Harmonics	-80 dB. Meets or exceeds FCC or CCIR specifications.
Carrier Shift	Less than 2% at 100% modulation.
Noise (Unweighted)	60 dB or better below 100% modulation at 5000 watts output.
Positive Peak Capability	125% positive peak program modulation capability at 5600 watts.
Power Factor	95%
Tubes	Modulator - 4CX3000A Power Amplifier - 3CX2500F3

Table 1-2. Mechanical/Environmental Characteristics

FUNCTION	CHARACTERISTIC
<p>MECHANICAL</p> <p>Height</p> <p>Width</p> <p>Depth</p> <p>Weight</p> <p>    Unpacked</p> <p>    Domestic Packed</p> <p>    Export Packed</p> <p>Cubic Area</p>	<p>78 inches (198.12 cm)</p> <p>72 inches (182.88 cm)</p> <p>32 inches (81.28 cm)</p> <p>1250 pounds (566.99 kg), approximate</p> <p>1600 pounds (727.75 kg), approximate</p> <p>1850 pounds (839.15 kg), approximate</p> <p>120 cubic feet (3.398 cubic meters), packed</p>
<p>ENVIRONMENTAL</p> <p>Temperature</p> <p>Humidity</p> <p>Altitude</p>	<p>-20° to +50°C (-4° to +122°F)</p> <p>0 to 95%</p> <p>0 to 7500 feet (2286 meters)</p>
<p>AIR VOLUME</p>	<p>1000 CFM</p>
<p>TEMPERATURE RISE (Air)</p>	<p>9°C</p>
<p>DISSIPATION</p>	<p>5.1 KW, 17,496 BTUH</p>
<p>CABINET THERMAL RADIATION</p>	<p>250W (estimated)</p>



## SECTION II

### INSTALLATION

#### 2-1. INTRODUCTION

2-2. This section of the manual details the various procedures used in preparing the HARRIS MW-5B AM BROADCAST TRANSMITTER for operation. The installation procedures are presented in a chronological order to minimize the time between incoming inspection and preoperational checkout. The installation effort is divided into mechanical and electrical procedures so that it is possible to perform simultaneous tasks. Preoperational inspection and checkout procedures are also included to ensure that the transmitter has been properly installed and is ready for operation. Standard safety practices should be employed and strict adherence to the cautionary notes specified in the procedures is stressed.

#### 2-3. INCOMING INSPECTION AND UNPACKING

2-4. The transmitter is normally shipped via private carrier. The cabinet is mounted on a pallet, covered with a protective microfoam material, and encased in a wooden crate. Smaller components and other internal assemblies which may be damaged during transport, are removed from the cabinet, covered with microfoam, and packaged in heavy-duty cardboard cartons. Each item removed from the transmitter cabinet is tagged with a control number corresponding to the Packing Check List which accompanies the shipment.

2-5. Care should be exercised in unloading the container to prevent injury to personnel or damage to the transmitter. Equipment capable of handling a 2000-pound (910 kg) load is to be used. Upon delivery, the shipping containers should be examined for indications of possible mishandling. If damage has occurred, retain shipping containers and immediately notify the carrier and HARRIS CORPORATION, Broadcast Transmission Division. Refer to paragraph 2-7, Returns and Exchanges.

2-6. Proper handtools are to be used in unpacking the shipping containers. The wooden crate is to be disassembled carefully to prevent damage to cabinet walls and finish. The parts inside the cartons are to be unwrapped with care to prevent dropping or having the smaller components discarded with the waste material. The control tags attached to each item are to be checked against the Packing Check List control numbers to verify the completeness of the shipment. Any discrepancy is to be reported immediately to HARRIS CORPORATION, Broadcast Transmission Division.

#### 2-7. RETURNS AND EXCHANGES

2-8. Damaged or undamaged equipment should not be returned until written approval and a Return Authorization is received from HARRIS CORPORATION, Broadcast Transmission Division. Special shipping instructions and coding will be provided to assure proper handling and prompt issuance or credit. Complete details regarding circumstances and reasons for return are to be included in the request for return. Custom equipment or special order

equipment is not returnable. In those instances, where return or exchange of equipment is at the request of the customer, or convenience of the customer, a restocking fee will be charged. All returns will be sent freight prepaid and properly insured by the customer. When communicating with HARRIS CORPORATION, Broadcast Transmission Division, specify the Factory Order Number or Invoice Number.

## 2-9. INSTALLATION

2-10. Installation of the MW-5B Transmitter is accomplished in three steps:

- a. Positioning the transmitter and installing removed components.
- b. Providing external connections.
- c. Performing the preoperational checks.

2-11. To assist in identifying parts and external connections, the following installation procedures include photographs, wiring diagrams, and outline drawings.

## 2-12. TRANSMITTER INSTALLATION

2-13. No special instructions are necessary for installing the transmitter as fastening to the floor is not required. Position the transmitter in the desired location with regard to accessibility of interconnecting wiring and interfacing equipment. Refer to figure 2-1 for dimensions and interface information.

## 2-14. INSTALLATION OF REMOVED COMPONENTS

**WARNING**

DO NOT CONNECT POWER SOURCE TO TRANSMITTER PRIOR TO COMPONENT INSTALLATION.

2-15. All components removed from the transmitter for shipment are tagged to facilitate reinstallation. Components removed for domestic ground transportation are listed below together with references to illustrations that show the components in their installed positions.

- a. Blower 1B1 - figure 2-2 sheet 1.
- b. Motor - figure 2-2 sheet 1.
- c. 4CX3000A tube 1V1 - figure 2-2 sheet 2 and paragraph 2-20.
- d. 3CX2500F3 tube 1V2 - figure 2-2 sheet 3 and paragraph 2-21.

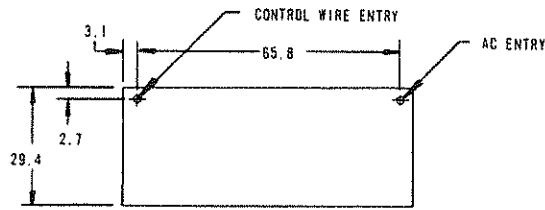
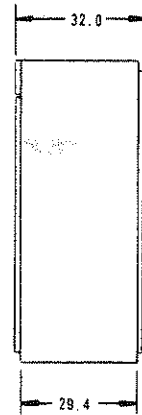
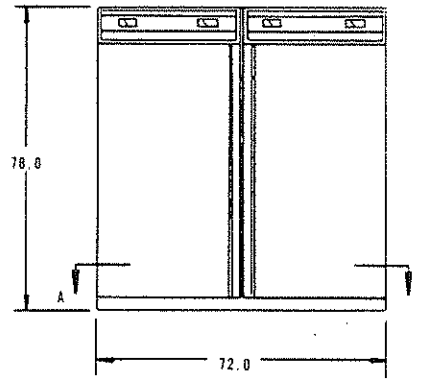
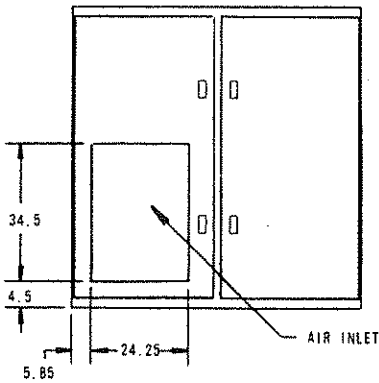
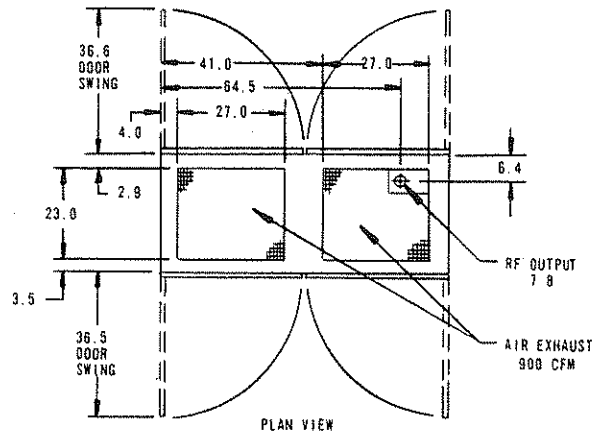

FIGURE 2-1. TRANSMITTER OUTLINE DRAWING  
839 5451 001

888-2109-010  
2-3/2-4

WARNING: Disconnect primary power prior to servicing.





- e. Transformer 1T4 - figure 2-2 sheet 4.
- f. Crystal 1 - figure 2-2 sheet 5.
- g. Crystal 2 - figure 2-2 sheet 5.
- h. Inductor 1L3 - figure 2-2 sheet 2.
- i. Feedthrough - figure 2-2 sheet 6.
- j. V-belt - figure 2-2 sheet 1.

2-16. For overseas air transportation all of the above components are removed plus the components listed below.

- a. Capacitor 1C1 - figure 2-2 sheet 1.
- b. Capacitor 1C3 - figure 2-2 sheet 3.
- c. Capacitor 1C14 - figure 2-2 sheet 6.
- d. Capacitor 1C15 - figure 2-2 sheet 2.
- e. Capacitor 1C18 - figure 2-2 sheet 6.
- f. Inductor 1L8 - figure 2-2 sheet 4.

#### 2-17. INSTALLATION OF VARIABLE CAPACITOR 1C14

2-18. Variable capacitor 1C14 may have been removed for shipment. The following adjustment of the capacitor/counter will be necessary.

- a. Reinstall the capacitor into the bracket and secure the fastener. Tighten the shaft into the counter mechanism leaving the counter shaft retaining screws loose.
- b. Set the counter to zero.
- c. Adjust the knob counterclockwise until the knob just starts to turn freely.
- d. Adjust the knob slowly clockwise until a slight amount of pressure is detected.
- e. Adjust the knob 1/4-turn further clockwise.
- f. With the counter set to zero, tighten the counter shaft retaining screws.
- g. Adjust the knob until the proper settings as called for in the Factory Test Data Sheets are indicated.

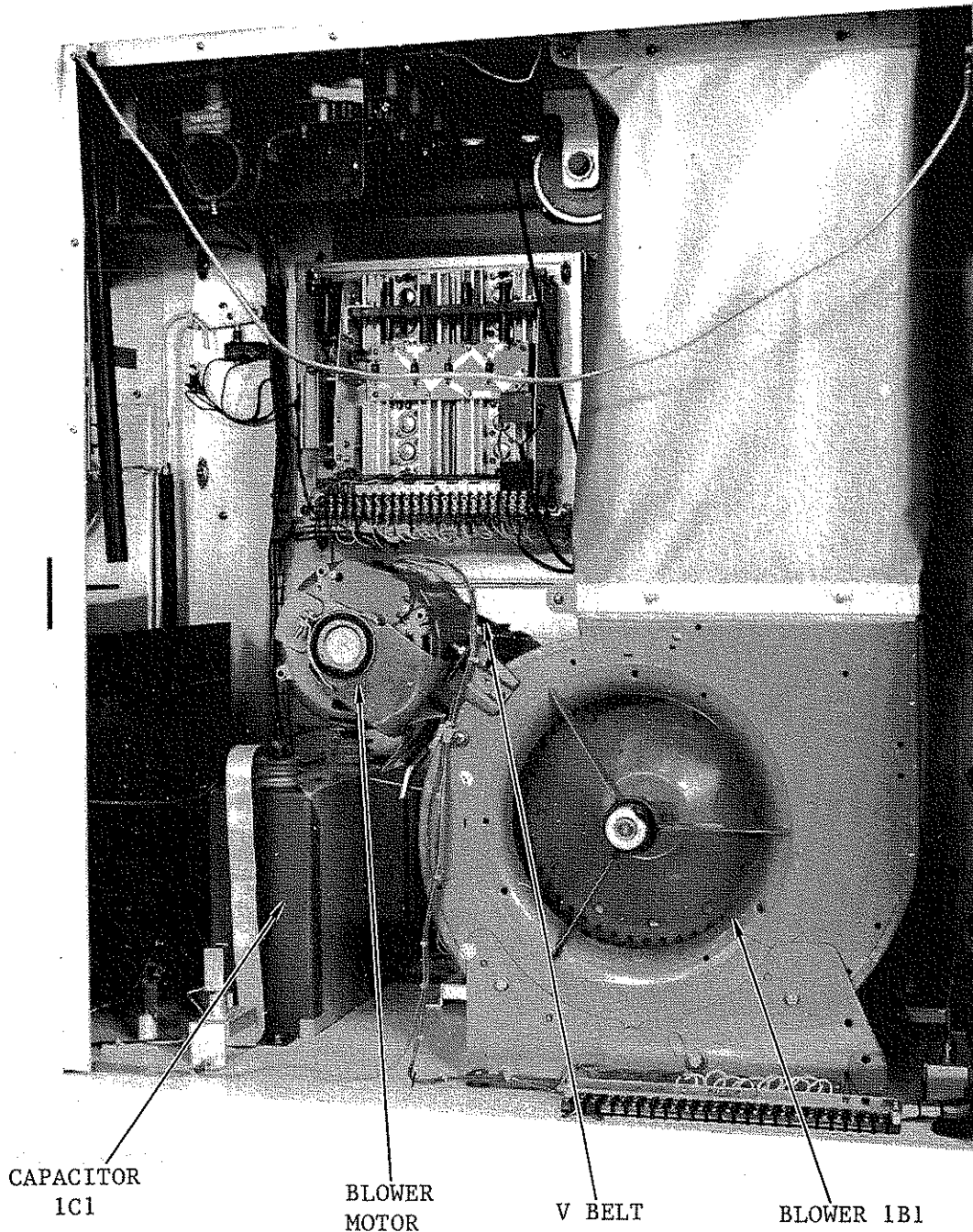

Figure 2-2. Transmitter Component Locations (Sheet 1 of 6)

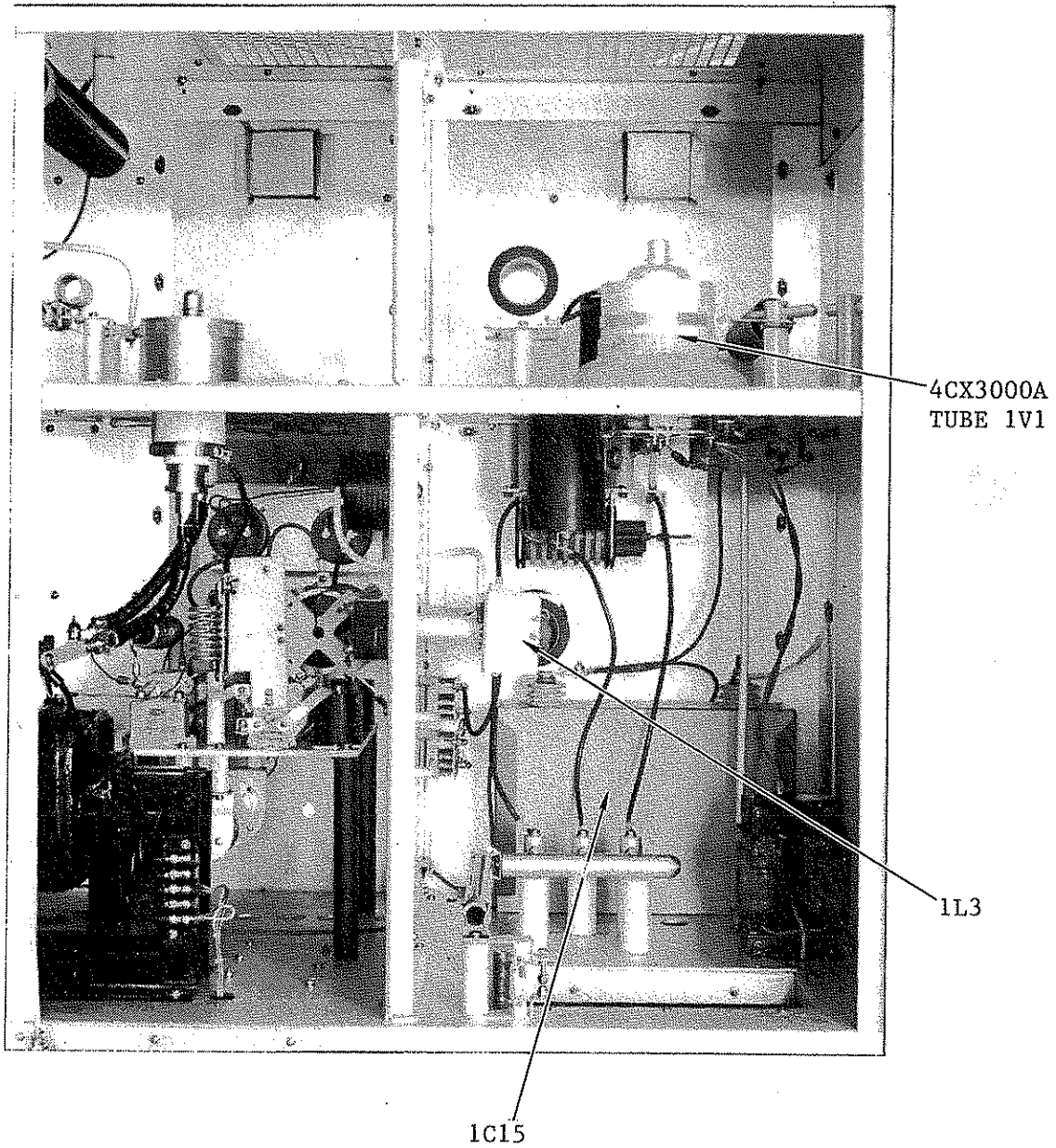
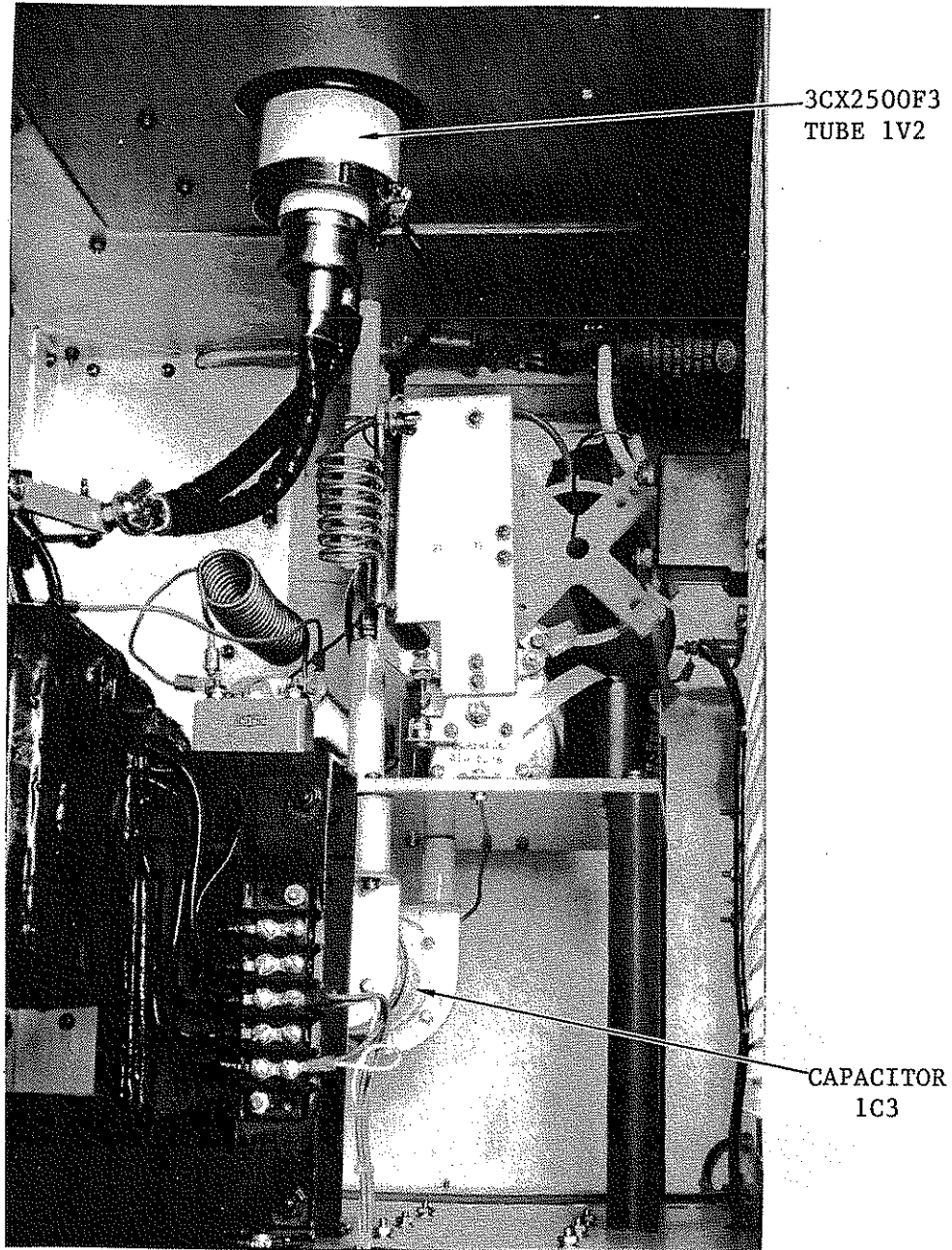

Figure 2-2. Transmitter Component Locations (Sheet 2 of 6)



3CX2500F3  
TUBE 1V2

CAPACITOR  
1C3

Figure 2-2. Transmitter Component Locations (Sheet 3 of 6)

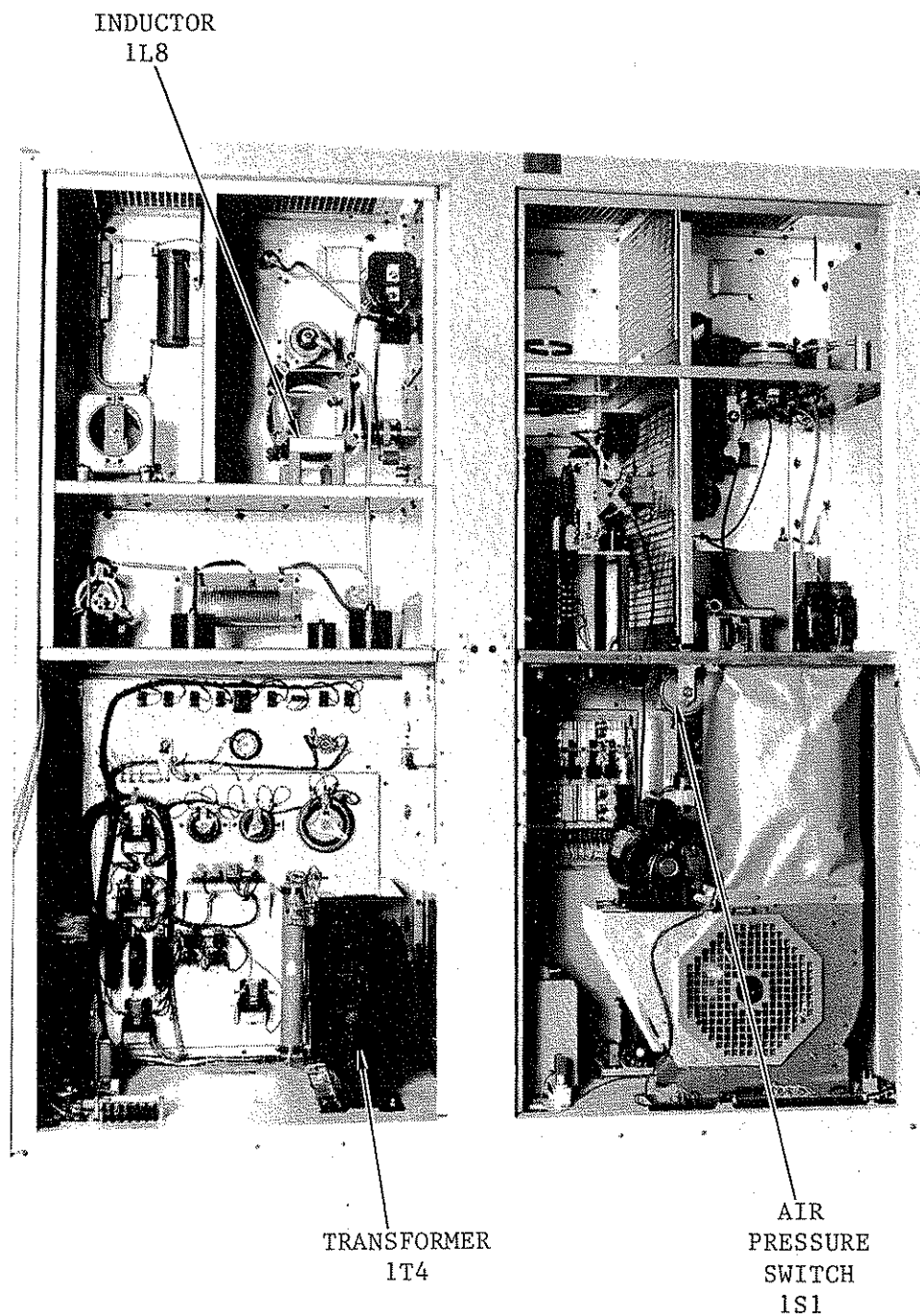

Figure 2-2. Transmitter Component Locations (Sheet 4 of 6)

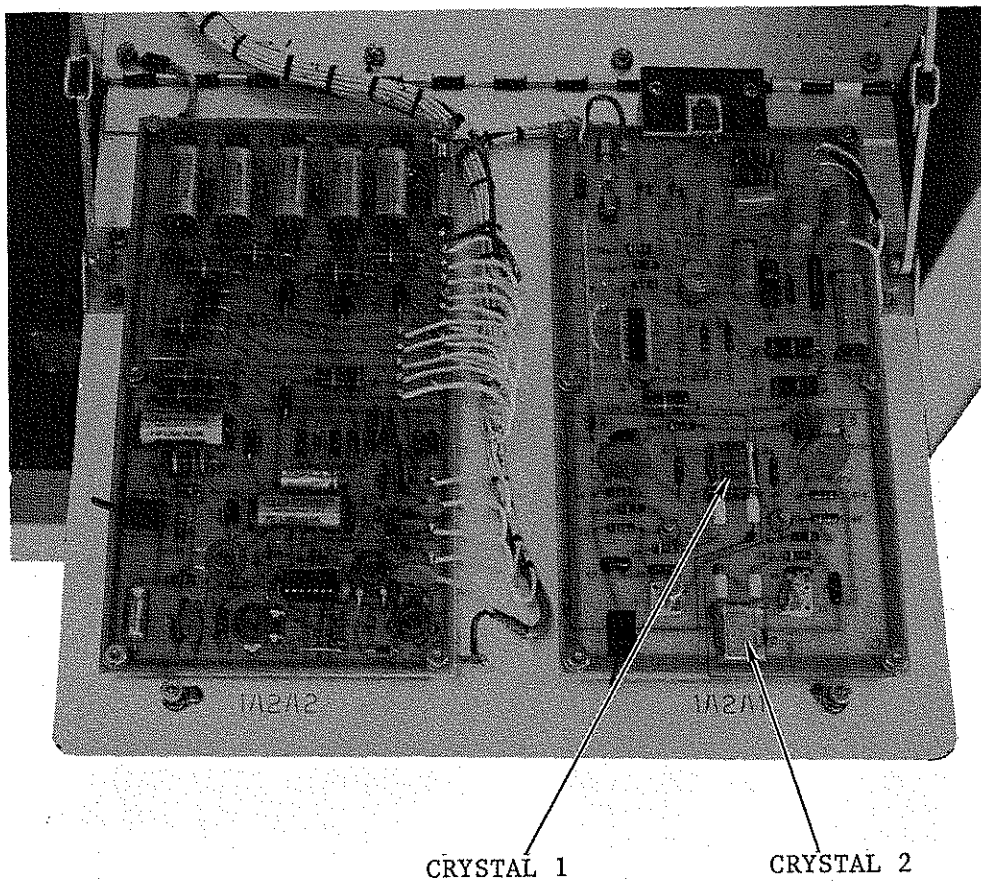

Figure 2-2. Transmitter Component Locations (Sheet 5 of 6)



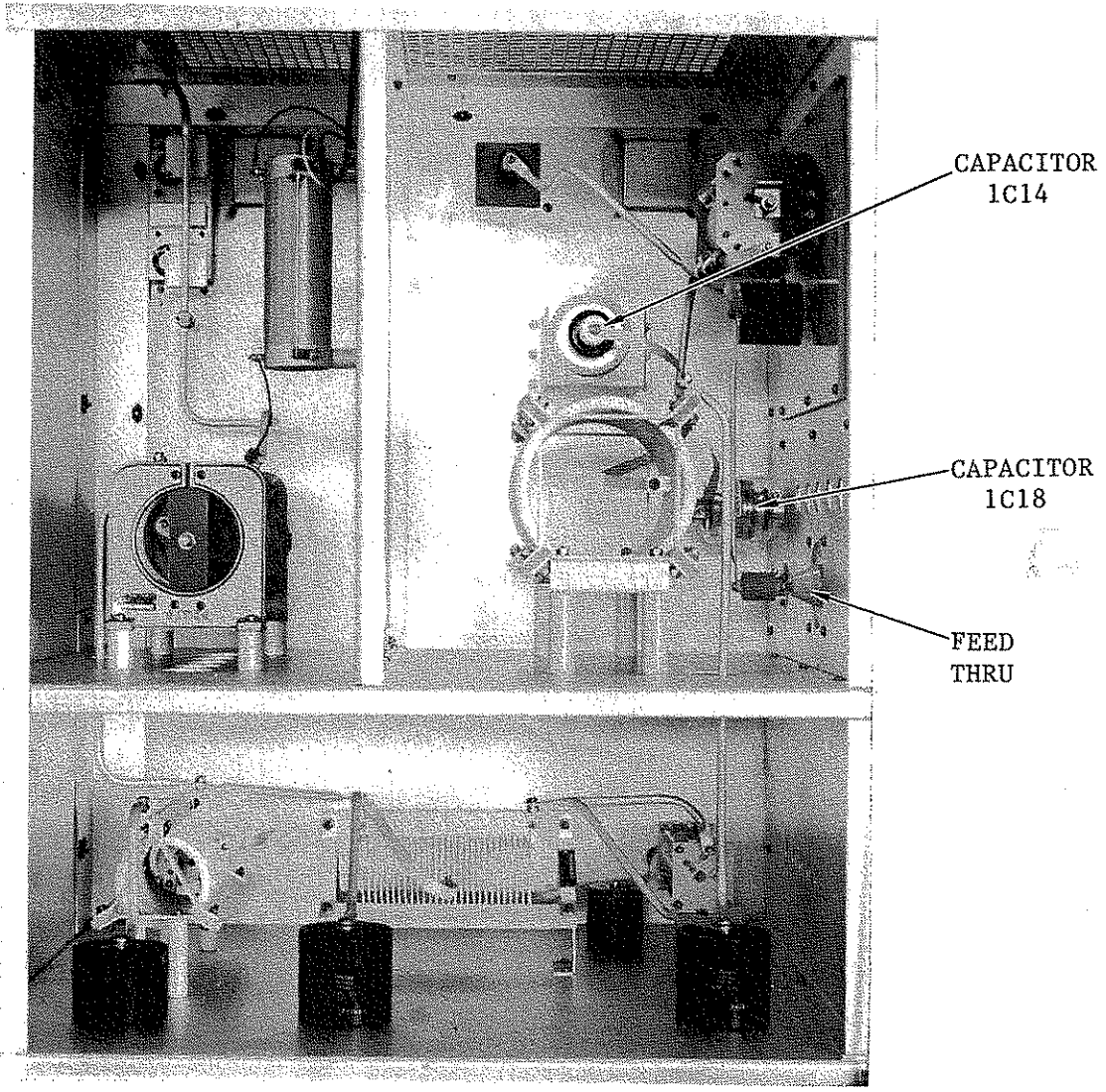

Figure 2-2. Transmitter Component Locations (Sheet 6 of 6)



2-19. A number of components in the transmitter have been taped or tied in position for shipment. Remove all tape, ties, and separators.

2-20. 4CX3000A MODULATOR TUBE INSTALLATION. Carefully lower the modulator tube into its socket and turn the tube clockwise approximately 1/4-turn until it contacts the end stop of the socket. Install the plate ring and tighten.

2-21. 3CX2500F3 POWER AMPLIFIER TUBE INSTALLATION. Lower the tube into its support with the filament and grid leads pointing down. Connect the filament and grid leads as shown in figure 2-2 sheet 3. Make sure the filament lead connections are as clean and tight as possible. Approximately 50 amperes flow through these leads and connections. If the connections are poor, the heat generated at these points will result in possible tube or connector damage.

#### 2-22. EXTERNAL CONNECTIONS

2-23. External connections required or available for this installation are: 1) primary power, 2) rf output, 3) audio input, 4) modulation monitor, 5) frequency monitor, 6) grounding, 7) external interlock, and 8) remote control connections. Refer to figure 2-3 for the external connections wiring diagram.

2-24. PRIMARY POWER. Customer specified 3-phase 208/230 volt, 60 Hz, or 3-phase, 380 volt, 50 Hz, primary power is required. Connections are made to terminals 1, 2, and 3 on terminal board TB1 (figure 2-3) if 208/230-volt, 3-phase primary power is used. If 380-volt, 50 Hz, 3-phase power is used, terminal 4 on terminal board TB1 is the neutral connection. Dependent upon primary power input, connect the high-voltage transformer as shown in figure 2-4.

### CAUTION

THIS EQUIPMENT IS DESIGNED FOR CONNECTION TO A 208/230-VOLT, 60 HZ CLOSED DELTA OR 380-VOLT, 50 HZ WYE POWER SERVICE. THE PRIMARY SERVICE MUST BE PROTECTED BY EITHER A CIRCUIT BREAKER OR FUSES WITH CURRENT RATING BETWEEN 40 AND 60 AMPERES. THE USE OF NUMBER 6 OR HEAVIER PRIMARY WIRE IS REQUIRED.

2-25. The following alterations and connections must be accomplished in order to operate the HARRIS MW-5B AM BROADCAST TRANSMITTER on a 380 Vac 4-wire input. Refer to figure 8-7.

- a. Remove wire 12 from relay K3 contact 5 and connect it to standoff insulator E3.
- b. Remove wire 61 from relay K4 and connect to standoff insulator E3.

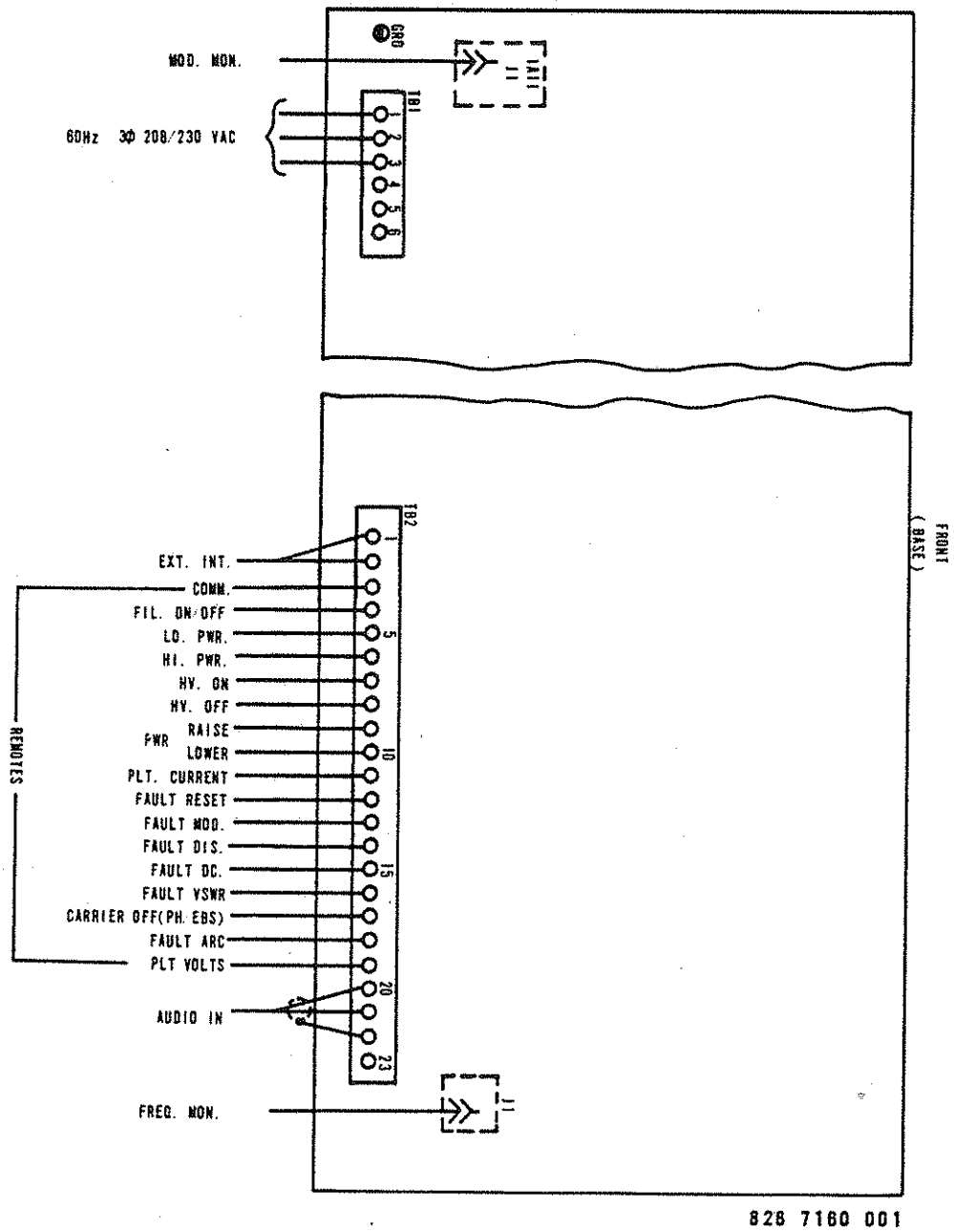

828 7160 001

Figure 2-3. Transmitter Interconnection Diagram

- c. Remove wire 87 from resistor R7 and connect it to standoff insulator E3.
- d. Rewire high-voltage transformer T4 to a Wye primary configuration (refer to figure 2-4 sheet 2).
- e. Add a gray wire, number 10 size, from transformer T4 Wye common, to terminal 4 on terminal board 1TB1.
- f. Stencil 380 Vac on entrance block .

2-26. RF OUTPUT. The rf output terminal is at the top, left rear of the transmitter (figure 2-5). A ground stud is located adjacent to the rf output insulated terminal.

NOTE

The output of the MW-5B AM BROADCAST TRANSMITTER is unbalanced to ground. The rf output impedance matches 50 to 300 ohms, as specified by the customer.

**WARNING**

THE RF OUTPUT TERMINAL OF THE TRANSMITTER, AND ANY OUTPUT WIRING, MUST BE ADEQUATELY SHIELDED FOR PERSONNEL SAFETY.

2-27. AUDIO INPUT (NORMALLY 600-OHM BALANCED). Using a shielded twisted pair, connect the two audio wires to terminals 20 and 21 on terminal board 1TB2 located in the cabinet on the right side (viewed from the rear of transmitter) near blower 1B1 (figure 2-5). Connect the shield (ground) to terminal 22.

2-28. MODULATION MONITOR. A modulated sample voltage at BNC connector J1, on chassis 1A11 (figure 2-5), is provided for Modulation Monitor operation. A BNC plug with RG58 coaxial cable is used to make this connection to the station Modulation Monitor.

2-29. FREQUENCY MONITOR. An unmodulated sample voltage for the station Frequency Monitor is provided at BNC connector J1 near the rear right-hand corner close to blower 1B1 (figure 2-5). A BNC plug with RG58 coaxial cable is used to make this connection to the Frequency Monitor.

2-30. TRANSMITTER GROUNDING STUD. The ground stud is located near the primary ac input terminal board (figure 2-5). A low-impedance ground bus, such as 2-inch copper strap, must connect from this terminal to the main ground system of the station.

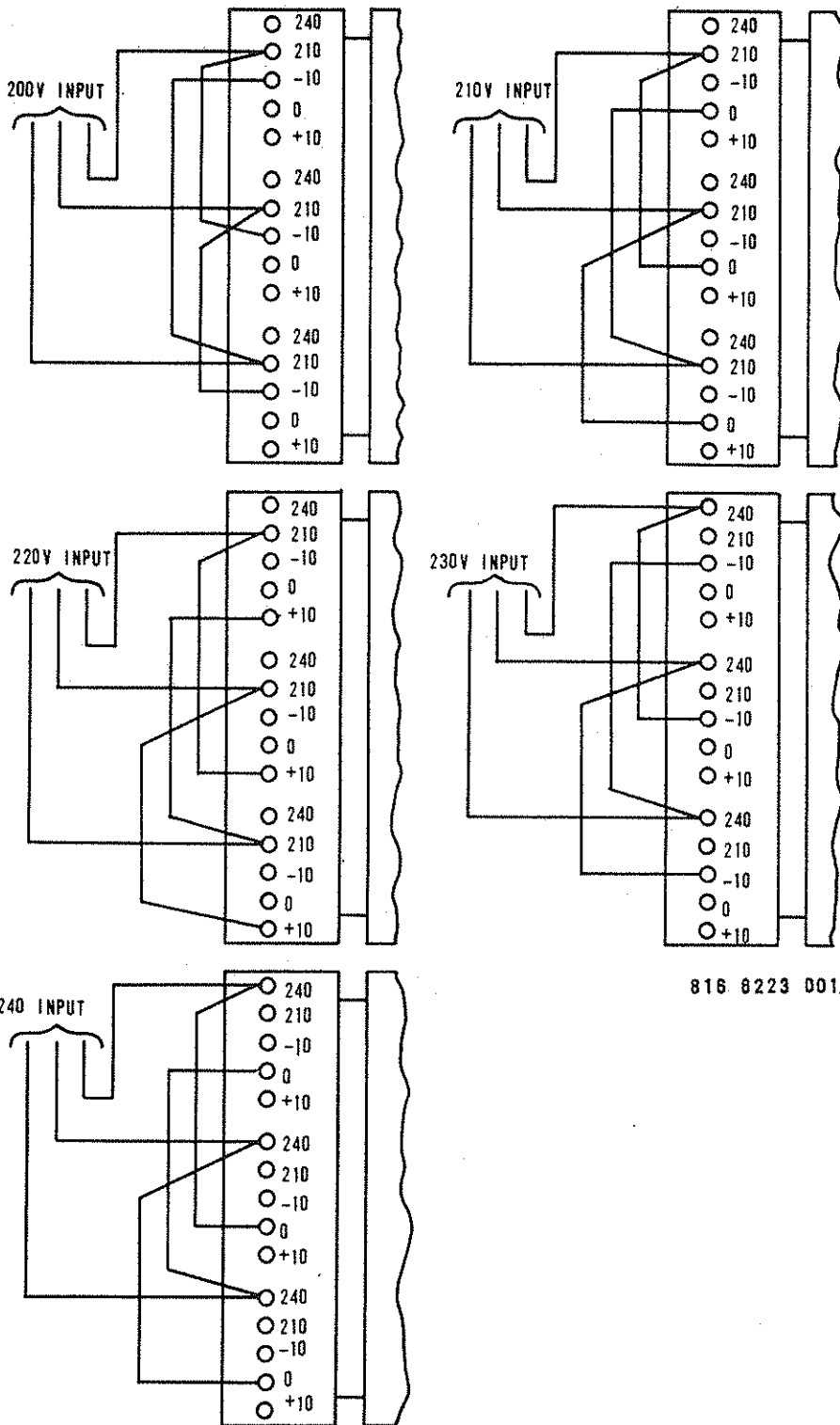

Figure 2-4. HV Transformer Connections, Wiring Diagram (Sheet 1 of 2)

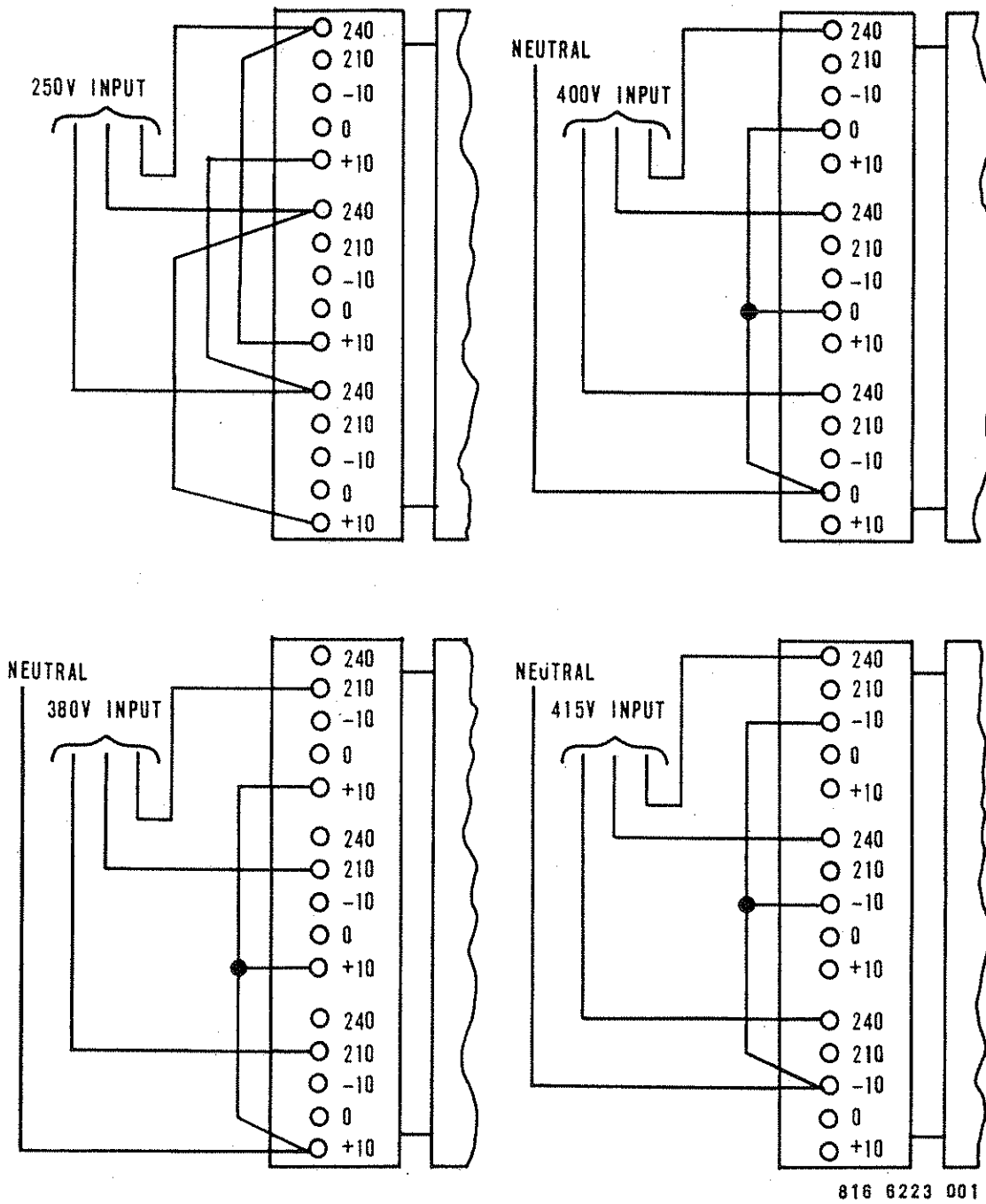
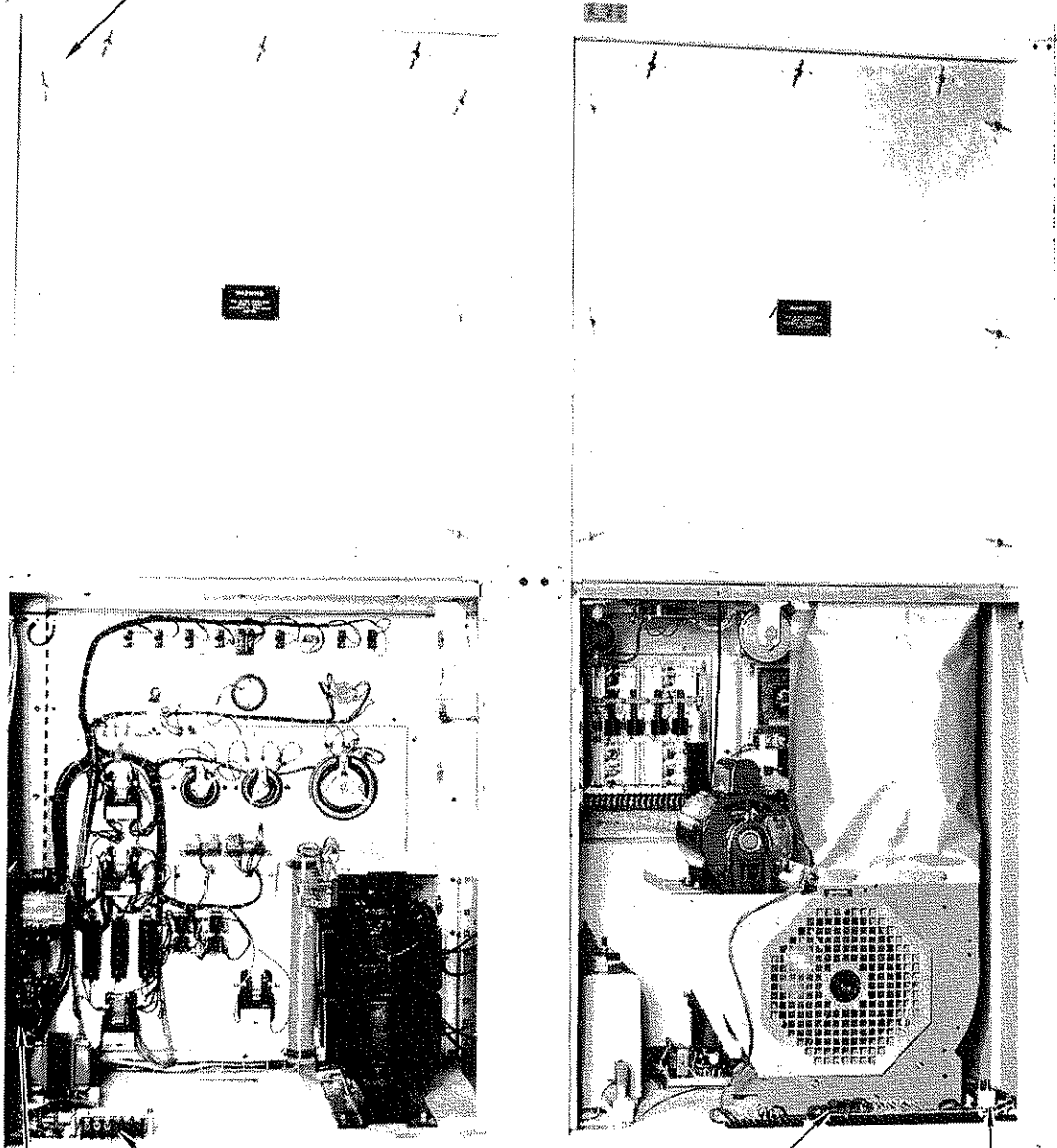

Figure 2-4. HV Transformer Connections, Wiring Diagram (Sheet 2 of 2)

RF OUTPUT  
CONNECTION  
(INSIDE CABINET)



MODULATION  
MONITOR  
CONNECTIONS

PRIMARY  
POWER  
CONNECTIONS

AUDIO INPUT  
AND REMOTE  
CONNECTIONS  
(1TB2)

FREQUENCY  
MONITOR  
CONNECTION

Figure 2-5. Transmitter Connection Locations

NOTE

The transmitter, antenna, and audio processing equipment must have a common ground.

2-31. EXTERNAL INTERLOCK. If external interlocking of the transmitter is required, remove the factory-installed jumper and connect the interlock circuit to terminals 1 and 2 on terminal board 1TB2 (figure 2-5).

NOTE

The transmitter shuts completely down if this interlock circuit is opened. The external interlock must be rated for 115 Vac and 2 amperes.

2-32. REMOTE CONTROL CONNECTIONS. All remote control connections are made to terminal board 1TB2, located on the rear base of the transmitter near blower 1B1 (figure 2-5).

- a. Filament On/Off (115 Vac Switching). A continuous closure is required to hold the filaments on during remote operation to meet the requirement for fail-safe operation when the transmitter is remotely controlled. Contacts must be rated for 115 Vac, 2 amperes. Connection is made to terminals 3 (ground) and 4.
- b. Low-Power Operation. Provision is made for a momentary closure (rated 115 Vac, 2 amperes) to switch the transmitter to low power. Connections are made to terminals 3 (ground) and 5. The carrier is not turned off during this switching operation.
- c. High-Power Operation. Provision is made for a momentary closure (rated 115 Vac, 2 amperes) to switch the transmitter to high power. Connections are made to terminals 3 (ground) and 6. The carrier is not turned off during this switching operation.
- d. High Voltage On. Provision is made for a momentary closure (rated 115 Vac, 2 amperes) to switch the transmitter high voltage on. Connections are made to terminals 3 (ground) and 7.
- e. High Voltage Off. Provision is made for a momentary closure (rated 115 Vac, 2 amperes) to switch the transmitter high voltage off. Connections are made to terminals 3 (ground) and 8.
- f. Raise Transmitter Power. Connections for a closure to raise transmitter power are made to terminals 3 (ground) and 9. The transmitter output power slowly increases during closure. Contacts must be rated at 115 Vac, 2 amperes.

- g. Lower Transmitter Power. Connections for a closure to lower transmitter power are made to terminals 3 (ground) and 10. The transmitter output power slowly decreases during closure. Contacts must be rated at 115 Vac, 2 amperes.
- h. Remote Plate Current Indication. Provision is made for a remote plate current indicator to be connected to terminals 3 (ground) and 11. The load impedance must be at least 10k ohms. An output of at least 1 volt dc is provided. This is a negative voltage sample.
- i. Remote Plate Voltage. Provision is made for remote plate voltage metering to be connected to terminals 3 (ground) and 19. An output of more than 1 volt dc is available. The load impedance must be at least 10k ohms.
- j. Remote Fault Indicators. An output of approximately 1 volt dc (across greater than 10k ohms) appears between terminals 3 (ground) and the associated fault readout as follows:
  - 1. Modulator - Terminal 13.
  - 2. Dissipation - Terminal 14.
  - 3. DC Overload - Terminal 15.
  - 4. VSWR Trip - Terminal 16.
  - 5. Arc - Terminal 18.
- k. Fault Indicator Reset. Provision is made for a momentary closure (rated 30 Vdc, 1 ampere) to reset the fault indicators located on the front panel of the transmitter and also those at the remote readout. Connections are made to terminals 3 (ground) and 12.
- l. Carrier Off (Phasor/Emergency Broadcast Service). Provision is made for a closure (rated 30 Vdc, 1 ampere) between terminals 3 (ground) and 17 to cause the transmitter output power to decrease to zero. The high voltage remains on, but the power amplifier turns off. Opening of this closure allows the power amplifier to turn on.

NOTE

The above function is used during EBS tests and phasor switching. Terminals 3 (ground) and 17 are closed while the phasor is switched. The transmitter may be switched to high or low power at the same time.



2-33. INITIAL PRE TURN ON MECHANICAL CHECKS

2-34. Complete the following mechanical checks:

**WARNING**

VERIFY THE MAIN AC INPUT LINE CURRENT BREAKER IS IN THE OFF POSITION, OR IF FUSES ARE USED, MAKE CERTAIN THE PRIMARY DISCONNECT SWITCH IN THE FUSE BOX IS OPEN. USE THE GROUNDING STICKS AND TOUCH EACH COMPONENT BEFORE TOUCHING THEM.

- a. Check that all connections on terminal boards in the transmitter are tight.
- b. Check the transmitter to ensure that there is no loose hardware in the unit. Check inside inductors for loose metallic hardware.
- c. Rotate blower manually to be sure impeller is free-turning with no obstructions present. Check blower belt tension in accordance with figure 2-6.

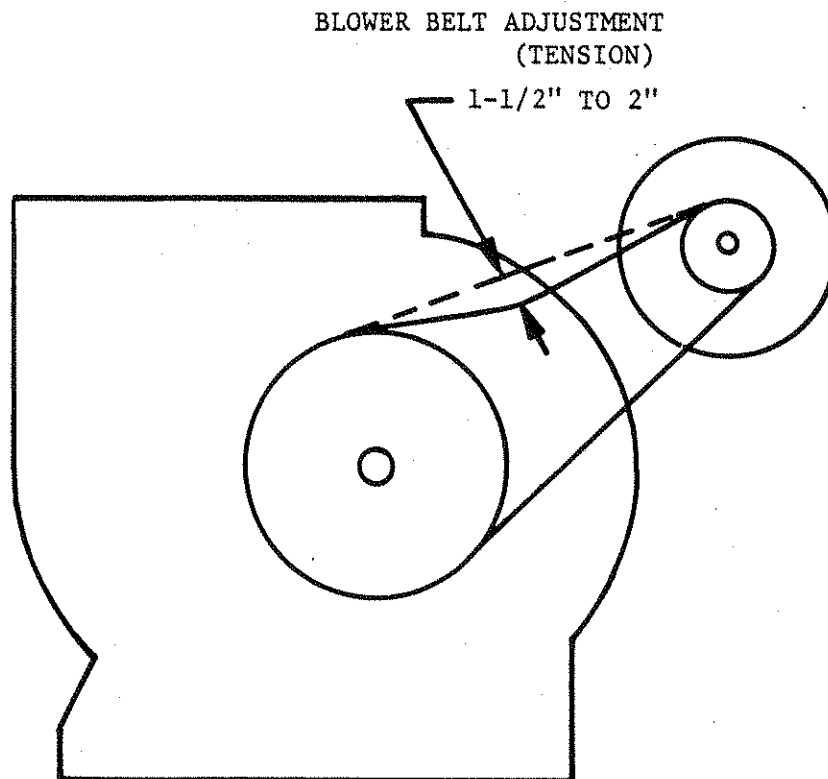

Figure 2-6. Blower Belt Tension Adjustment

- d. Check all relays and contactors for free armature and contact movement. Operate manually to check armature movement.
- e. Check wire and cable routing to preclude possibility of chafing against sharp metal edges.
- f. Verify that all transmitter panel shielding is in place and that all interlocked panels are secured.

2-35. INITIAL PRE TURN ON ELECTRICAL CHECKS

2-36. Complete the following electrical checks:

- a. Check that the primary connections to the high-voltage power transformer are in accordance with figure 2-4.
- b. Check the following transmitter controls for proper settings:
  - 1. Adjust fine POWER ADJUST potentiometer 1A1R2 (figure 3-6) on PDM chassis front panel to center range.
  - 2. Adjust PA TUNE variable capacitor 1C14 and PA LOAD variable inductor 1L12 (figure 3-4) to counter number shown on Factory Test Data Sheet.
  - 3. Adjust FILAMENT VOLTAGE rheostat 1A4R4 (figure 3-5) to midrange.
  - 4. Open PDM chassis front hinged panel (figure 3-8), and adjust the following potentiometers on PDM control printed-circuit board 1A1A2:
    - a) LO PWR potentiometer R53 - maximum counterclockwise.
    - b) HI PWR potentiometer R52 - maximum counterclockwise.
- c. Check that the front panel circuit breakers are set to the ON position.
- d. Check that all grounding sticks are mounted in their interlock holders and are not touching any wires or transformers.
- e. Check that the external interlock connections at terminals 1 and 2 on terminal board 1TB2 (next to blower) are either jumpered or connected to an external closed circuit (transformer cannot be started if these terminals are open).
- f. Operate the MULTIMETER switch to the RF DRIVER CURRENT position.

**WARNING**

EXTREMELY DANGEROUS VOLTAGES ARE GENERATED WITHIN THIS TRANSMITTER. DO NOT MAKE ADJUSTMENTS INSIDE THE TRANSMITTER WITH PRIMARY OR SECONDARY VOLTAGES ON. DEENERGIZE THE TRANSMITTER WHEN MAKING ADJUSTMENTS. DO NOT BYPASS THE INTERLOCKS. AT LEAST TWO PERSONS SHOULD BE PRESENT WHEN WORKING ON THE TRANSMITTER. ALWAYS GROUND CIRCUITS WITH A GROUNDING STICK BEFORE TOUCHING THEM.

- g. Check that ball gaps E1, 3, 4, 5 are set to 0.50 inches, E6 is set to 0.010 inches, E7 is set to 0.250 inches, and that ball gap 1A3E1 is set to 0.040 inches.
- h. Check that the following door interlocks are closed:
  - 1. Left Rear Door.
  - 2. Right Rear Door.
  - 3. AC Control Door.
  - 4. Audio Driver Access Door.
  - 5. RF Driver Access Door.

2-37. PRIMARY POWER APPLICATION

2-38. Complete the following steps for primary power application:

- a. Apply 3-phase primary power to the transmitter.
- b. Set LOCAL/REMOTE switch to LOCAL.

**CAUTION**

PRIOR TO PERFORMING THE FOLLOWING STEP, ENSURE THAT ALL DOORS ARE TIGHTLY CLOSED. IF AIR PRESSURE DOES NOT BUILD UP, THE BLOWER WILL RUN TOO FAST AND OVERHEAT.

- c. Depress FILAMENT ON pushbutton switch. The FILAMENT ON switch illuminates to indicate that all internal and external interlocks and the control circuit breaker are closed. Blower energizes and when blower pressure is built up the isolated meter panel illuminated.

- d. Open the front panel of the RF Oscillator/Driver Chassis and connect a clip lead from terminal 5 of the oscillator printed-circuit board to ground to energize the Oscillator and RF Driver. Adjust the PA GRID TUNE control to peak the PA grid meter on the lighted meter panel. Check that current on the multimeter is between 6 and 9 amperes. Check that the PA grid current is between 240 and 270 milliamperes. If more than 9 amperes of rf driver current or less than 240 mA or PA grid current is indicated, turn transmitter off and make the following adjustments:
1. Depress FILAMENT ON pushbutton switch. Jumper terminal 5 of oscillator printed-circuit board to ground. Peak PA grid current.

**WARNING**

USE THE GROUNDING STICK AND SHORT OUT ALL COMPONENTS BEFORE TOUCHING THEM.

2. Open RF Driver interlocked panel and loosen screws which hold the slug assemblies for inductors L3, L4, L5, and L6. If rf driver current is more than 9 amperes, move each slug into its coil 1/4-inch. If rf driver current is less than 9 amperes, move each slug out of its coil 1/8-inch. Tighten screws and close RF Driver interlocked panel. If RF Driver current is still incorrect, repeat steps 1 and 2.
- e. Open the RF Driver Chassis front panel and adjust IPA OUTPUT ADJUST potentiometer 1A2A3R4 (figure 3-7), on the bottom of the chassis, counterclockwise. Monitor the PA grid current and back the IPA control clockwise until the grid current begins to decrease. Check that rf driver current on the multimeter indicates between 7 and 9 amperes. Tune the PA GRID TUNE control as described in step d. for proper operation.
- f. Remove the clip lead jumper from oscillator printed-circuit board terminal 5 to ground. The PA grid current goes to zero, and the RF OUTPUT lamp on the printed-circuit board extinguishes.

**CAUTION**

FAILURE TO REMOVE THE ABOVE JUMPER CAN CAUSE THE STEP-START OVERLOAD TO TRIP WHEN THE HIGH VOLTAGE IS TURNED ON.

- g. For maximum tube life, the filament voltage should be adjusted for minimum value consistent with proper performance after several days of operation on each new tube. This initial burn-in will season the tube and insure stable operation throughout tube life.

Filament voltage must be gradually increased throughout tube life as performance degradation dictates.

- h. Depress the HIGH VOLTAGE ON pushbutton switch and verify output power, plate current on the lighted meter panel, and plate voltage on the right top meter panel, all should read near zero. If the HV Protection LED is illuminated, an adjustment of the GAIN ADJUST potentiometer on the High-Voltage Protection board will be necessary. Adjust the potentiometer 1 or 2 turns counter-clockwise to prevent a shutdown.
- i. Operate MULTIMETER switch to FILAMENT VOLTS and adjust FILAMENT voltage control (figure 3-5) for 92 percent on the multimeter (full scale corresponds to 120 percent).
- j. Operate the MULTIMETER switch and verify multimeter indications are in accordance with the FIL. ONLY column in figure 2-7.
- k. Depress the HIGH VOLTAGE pushbutton switch and verify output power. Plate current on the lighted meter panel and plate voltage (right top meter panel) read near zero.
- l. Depress the HIGH POWER pushbutton switch on the left meter panel. Check that switch indicator illuminates.
- m. Operate the MULTIMETER switch and verify multimeter indications in accordance with the HV ON, ZERO POWER column in figure 2-7.
- n. Open PDM chassis front panel. Adjust HI PWR potentiometer R52, on PDM control board 1A1A2, slowly clockwise while observing the PA plate current on the isolated meter panel and the PA plate voltage on the right meter panel. Adjust potentiometer R52 clockwise until the PA plate current reaches 0.5 ampere (1/3 scale) or until the PA plate voltage reaches 2300 volts (approximately 1/3 scale).
- o. Dip the PA plate current by adjustment of the PA TUNE control.
- p. After completion of the preceding steps, the power amplifier is initially loaded. Using HI PWR potentiometer R52 on PDM control board 1A1A2, which controls the plate voltage, the PA LOAD control, which adjusts the PA plate current, adjust the PA plate voltage to 2300 volts and the PA plate current to 0.5 ampere. Do not exceed either value.
- q. Verify the following indications:
  1. Supply Current - 0.09 to 0.11 ampere.
  2. Power Output - 1 kW.
  3. PA Grid Current - at least 230 mA.

MULTIMETER	FIL. ONLY	HV ON, ZERO POWER*	HV ON, 5 kW NO MOD.	HV ON, 5 kW 95% MOD.	HV ON, 1 kW NO MOD.	HV ON, 1 kW 95% MOD.
AUD. DVR, I	30-60 mA	210-250 mA	110-125 mA	105-120 mA	125-135 mA	125-135 mA
AUD, DVR, V	0	0	85-105V	90-110V	40-60 mA	40-60 mA
MOD. BIAS, V	210-225V	210-225V	115-125V	110-125V	160-180V	160-180V
AUX. DVR, I	0	0	5-30 mA	20-30 mA	0-5 mA	0-5 mA
MOD. SCR, I	0	0.2-0.3A	0.35-0.45A	0.3-0.5A	0.18-0.25A	0.18-0.25A
MOD. SCR, V	0	350-400V	325-400V	325-400V	250-350V	250-350V
IPA, I	0	0.9-1.1A	0.9-1.1A	0.9-1.1A	0.9-1.1A	0.9-1.1A
RF DVR, I	0	7-9A	7-9A	7-9A	7-9A	7-9A
RF DVR, V	55-60V	45-50V	45-50V	45-50V	45-50V	45-50V
SUPPLY, I	0	0	0.4-0.5A	0.6-0.7A	0.09-0.11A	0.14-0.18A
SUPPLY, V	0	13.5-15 kV	13-14 kV	12.5-13.5 kV	13.5-14.5kV	13.5-14.5kV
FIL. V, %	92%	92%	92%	92%	92%	92%
<u>ISOLATED METER PANEL</u>						
PLATE I	0	0-.05A	1.15A	1.16A	.525-.550A	.525-.550A
GRID I	0	250-280 mA	240-270 mA	240-270 mA	240-270 mA	240-270 mA
<u>RIGHT METER PANEL</u>						
PWR AMP, V	0	200, or less	5300V	5400V	2200-2400V	2200-2400V
PWR (FORWARD)	0	0	5 kW+	5 kW+	1 kW	1 kW

\*HIGH POWER POSITION

Figure 2-7. Typical Multimeter Indications

- r. Because antenna systems differ, VSWR overload may occur. In the event of an overload, open the RF Driver Chassis panel and adjust the following controls on Overload Board 1A2A2:
1. THRESHOLD ADJUST potentiometer R26. Adjust counterclockwise until VSWR fault lamp on the right meter panel illuminates, then clockwise 1/8-turn. Reset the FAULT indicator by depressing the RESET pushbutton switch on the right meter panel.
  2. VSWR SENSITIVITY potentiometer R32. Adjust to maximum sensitivity (fully counterclockwise).
- s. Adjust VSWR overload switching as follows:

NOTE

If the load impedance differs from the factory specification, the power meter must be adjusted.

1. To prevent operation of VSWR overload during the following procedure, adjust THRESHOLD ADJUST potentiometer R26 on Overload Board 1A2A2 fully clockwise (refer to figure 3-9).
2. Adjust the transmitter for a 5 kW unmodulated output as determined by a calorimetric load or other known accurate means. This output should occur when the plate voltage is approximately 5300 volts, plate current is 1.15 amperes, and the supply current is 0.5 amperes.
3. Operate the power meter switch to the REFLECTED position and null the meter using variable capacitor 1A8C3 (refer to figure 3-3). Turn the transmitter off. Remove the retaining screws, invert, and reinstall the Directional Coupler in the transmitter. Return the transmitter to 5 kW output.
4. Operate the power meter switch to the FORWARD position and null the meter using variable capacitor 1A8C9. Operate the power meter switch to the REFLECTED position and calibrate the meter, using REFLECTED CALIBRATION potentiometer 1A8R2, to the calorimetric power (refer to figure 3-3).
5. Reinstall the Directional Coupler to its normal position and operate the power meter switch to the FORWARD position. Calibrate the meter for forward power, using FORWARD CALIBRATION potentiometer 1A8R7, to the calorimetric power (refer to figure 3-3).
6. Repeat steps 3. through 5. to minimize the interaction effects of the FORWARD and REFLECTED CALIBRATION controls.

7. Adjust VSWR overload potentiometer R26 counterclockwise until the VSWR fault indicator illuminates and then clockwise 1/16 of a turn (refer to figure 3-9).
  8. Activate the transmitter for a 300-watt unmodulated output.
  9. Turn off the transmitter and invert the Directional Coupler.
  10. Reactivate the transmitter and adjust VSWR overload potentiometer R32 (refer to figure 3-9) until the VSWR fault lamp illuminates.
  11. Turn off the transmitter and reinstall the Directional Coupler in its normal position. Seal adjustment capacitors C3 and C9, and potentiometers R2 and R7 (refer to figure 3-3).
- t. Adjust HI PWR control potentiometer R52 clockwise to obtain a plate voltage of 5300 volts. Adjust the PA LOAD control to obtain 1.15 amperes of PA plate current as indicated by the PA PLATE CURRENT meter on the lighted meter panel. Check that the PA plate current is still dipped by adjusting PA TUNE variable capacitor 1C14. Verify that power output is over 5000 watts and that supply current is less than 0.50 amperes.
  - u. Operate the power meter switch on the right meter panel to EFFICIENCY position. If power meter does not indicate midscale, open the meter panel and adjust EFFICIENCY METER ADJUST potentiometer 1A9R4 for a 1/2-scale reading (refer to figure 3-3).
  - v. With the power meter switch in the EFFICIENCY position, adjust PA TUNE variable capacitor 1C14 for a maximum reading on the power meter. Adjust PLATE EFFICIENCY RESONATOR variable inductor 1L5, behind the right meter panel, for a maximum reading on the power meter (refer to figure 3-4).
  - w. Adjust PA GRID EFFICIENCY variable capacitor 1A3C2 for a dip in the plate voltage. Repeat steps r. through u. until no change is noted.

**WARNING**

USE EXTREME CAUTION WHEN INSERTING THE PROBE THROUGH THE PA ENCLOSURE SCREEN. DANGEROUS HIGH VOLTAGE IS PRESENT IN THE ENCLOSURE. INSERT THE PROBE ONLY 1 INCH INTO THE ENCLOSURE.

- x. If unable to attain the specified indications in step t. and u. insert an oscilloscope probe through the top screen into the PA



enclosure. POSITION THE PROBE 5 INCHES OR MORE AWAY FROM HIGH-VOLTAGE AREAS. Tune PA PLATE EFFICIENCY RESONATOR variable inductor 1L5 (behind the right meter panel) and PA GRID EFFICIENCY variable capacitor 1A3C1 for the waveform shown in figure 2-8. The cathode 3rd harmonic resonator coil tap position may have to be changed if the factory setting has been moved.

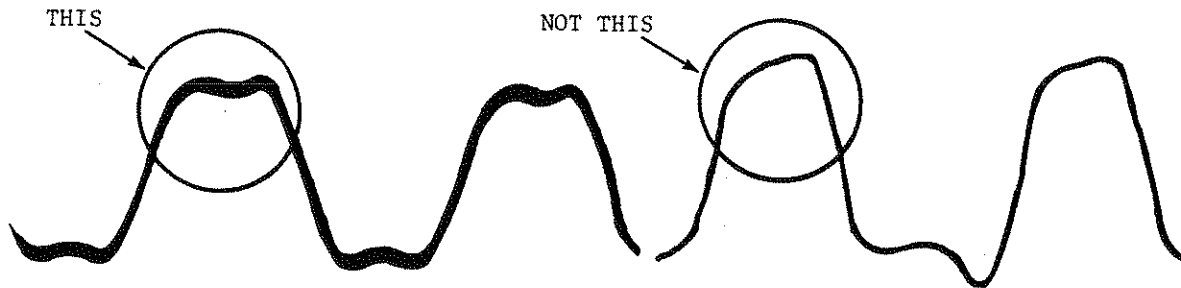

Figure 2-8. Power Amplifier Waveform

- y. Verify that all meter indications are in accordance with columns 5 KW ZERO MODULATION and 5 KW 100% MODULATION in figure 2-7.

NOTE

Refer to the Factory Test Data Sheets for characteristic readings.

- z. Modulate the transmitter 90 percent with a 1000 Hz tone. The distortion should be less than 1.5 percent. The power amplifier GRID RESONATOR may be adjusted slightly to reduce the distortion but must not be adjusted to cause more than a 50-volt increase in the PA plate voltage. PA plate voltage should dip when the GRID EFFICIENCY control is tuned correctly. If a transformer shutdown occurs and the HV Protection LED is illuminated, an adjustment of the HV GAIN potentiometer will be necessary. Adjust the potentiometer 1 or 2 turns counterclockwise to prevent transmitter shutdown when the transmitter is modulating at 1000 Hz.
- aa. A high power proof-of-performance may now be accomplished.
- ab. DISS potentiometer R38 and CARRIER SHIFT potentiometer R35, on PDM control feedback board 1A1A2, are factory adjusted for best performance with overload protection. These controls should be adjusted as described below if problems are encountered during the proof-of-performance test.

1. Adjust DISS potentiometer R38 to maximum counterclockwise position to prevent overload trips during test. The DC OVERLOAD variable resistor 1A4R9 may require slight counterclockwise adjustment to prevent tripping at 50 Hz or below.
2. Modulate the transmitter 95 percent at 1000 Hz. Adjust CARRIER SHIFT potentiometer R35 clockwise to reduce carrier shift to zero.

NOTE

MOD SCN VOLTAGE HI POWER control on the AC Power Panel will affect distortion slightly. AUX MOD ADJUST control R3 will also affect distortion. Adjust the control as far counterclockwise as possible while still meeting distortion specifications. The AUX DRIVER draws 60 mA at 95 percent modulation, 5 kW, 1000 Hz tone. This may have to be reduced to 20-30 mA or less if the modulator tube has a higher average gain. This can be determined by monitoring the distortion while adjusting the AUX DRIVER control. Operate using a maximum of 60 mA AUX DRIVER current.

- ac. At frequencies above 5000 Hz, sideband clipping can occur at modulation levels due to high Q antenna systems. Measure distortion at 50 percent and then increase modulation percentage in 10 percent increments, checking distortion at each level. If the distortion should suddenly increase at a modulation level of less than 95 percent, the antenna should be carefully examined for a possible change in impedance at frequencies above and below the transmitter carrier frequency. If a flat dummy load is available, the transmitter can be checked for proper operation.
- ad. A compromise setting of all distortion-affecting adjustments is made to minimize distortion at both high and low power. The following controls affect distortion:
  1. Screen voltage rheostats.
  2. Carrier shift potentiometer (mainly low frequencies).
  3. 75 kHz oscillator slug-tuned coil (mainly high frequencies).
  4. 3rd Harmonic resonators (gross mistuning will cause arcing).
  5. Auxiliary modulation potentiometer 1A1R3.
  6. Auxiliary driver potentiometer 1A1A3R8.

7. PA plate tuning (especially 5 to 10 kHz).
- ae. Modulate the transmitter 95 percent at 40 Hz and adjust DC OVERLOAD variable resistor 1A4R9 until the transmitter trips off.

NOTE

DC Overload trips may be experienced with highly processed programming. DC OVERLOAD variable resistor 1A4R9 may require adjustment to trip at 30 Hz.

- af. Modulate the transmitter 90 percent at 40 Hz, and adjust DISS limiter potentiometer R38 on the PDM control board counterclockwise until the transmitter trips off.

NOTE

DC Overload trips may be experienced with highly processed programming. DISS limiter potentiometer R38 on the PDM control board may require adjustment to trip at 30 Hz.

- ag. Modulate the transmitter at 100 percent with 100-120 Hz. Adjust the GAIN ADJUST control to the threshold of tripping, then adjust counterclockwise 3 turns. If an audio generator was not available for modulating the transmitter, leave the GAIN ADJUST control set as far clockwise as possible without the circuit tripping under normal modulation conditions.
- ah. If the sensitivity adjustment is to be completed without the aid of an Audio Generator, circuit trips may occur when modulating signals in the 90-130 Hz range. This will result in unwanted transmitter shutdown. In this case, the transmitter can be immediately restored to operation. If unwanted circuit trips occur during the first few days of operation, adjust the GAIN ADJUST potentiometer 1 or 2 turns counterclockwise to avoid random trips. Use an Audio Generator as soon as conveniently possible.
- ai. Modulate the transmitter 95 percent at 1000 Hz. Verify meter indications are in accordance with the 5 KW, 95% MODULATION column of figure 2-7.
- aj. Depress the LOW POWER pushbutton switch (the high voltage need not be turned off). The rf output should go to zero. Adjust LO PWR control R53 on PDM control board 1A1A2 for desired output power. Modulate 90 percent with a 1000 Hz tone, and adjust the MOD SCN VOLTAGE LOW POWER control, on AC Control Panel 1A4, for minimum distortion. Verify meter indications are in accordance

with the 1 KW ZERO MODULATION and 1 KW, 95% MODULATION at 1000 HZ columns of figure 2-7 or the Factory Test Data Sheet received with the transmitter.

- ak. Run a complete proof-of-performance on the transmitter. A compromise setting of the low-power modulator screen voltage may have to be made to meet specifications at all frequencies.
- al. Adjust LO PWR AUDIO potentiometer R2 on PDM control board 1A1A2 to balance the low-power and high-power modulation levels.
- am. Depress the HIGH POWER pushbutton switch and adjust the HIGH POWER control for the rf power required.

**CAUTION**

DO NOT OPERATE ABOVE 5500 VOLTS OR  
1.25 AMPERES ON THE POWER AMPLIFIER.

2-39. REMOTE METER CALIBRATION

2-40. REMOTE PA PLATE CURRENT METER 1A7M2 CALIBRATION

- a. With the transmitter operating at high power (5 kW), adjust TRACKING potentiometer 1A7R1 until meter 1A7M2 indicates the same as meter 1A3M1.
- b. Switch to low power output (1 kW) and adjust CALIBRATION potentiometer 1A7R4 until meter 1A7M2 indicates the same as meter 1A3M1.
- c. Repeat steps a. and b. as required to obtain meter indications within ±1 percent of each other at both power levels.

NOTE

If a remote test fixture is removed or added, the meter indications will change and recalibration will be required.

2-41. REMOTE PLATE CURRENT SAMPLE ADJUSTMENT

2-42. The following is a procedure to accomplish the adjustment of a Plate Current meter installed in a location remote from the transmitter.

- a. Depress HIGH VOLTAGE OFF pushbutton switch.
- b. Depress FILAMENT OFF pushbutton switch.

- c. Open the right rear transmitter door (facing rear of transmitter) exposing the blower and terminal strip 1TB2.

**WARNING**

USE THE GROUNDING HOOK TO DISCHARGE ANY  
RESIDUAL POTENTIAL FROM ALL EXPOSED  
COMPONENTS BEFORE TOUCHING THEM.

- d. Connect the leads of a remote plate current meter which has a scale range compatible with the PA PLATE current meter (10k-ohm/-volt or greater) between terminal 11 of terminal board 1TB2 and chassis ground. Route the lead wires to the outside of the transmitter.
- e. Close and latch the right rear transmitter door.
- f. Depress FILAMENT ON pushbutton switch.
- g. Depress HIGH VOLTAGE ON pushbutton switch.
- h. Operate the transmitter at high power and record the readings of the PLATE CURRENT meter and also the remote plate current meter.
- i. Switch the transmitter to operate at low power, again record the readings as in step h. The percentage of decrease between the high and low-power readings on the PLATE CURRENT meter and the remote meter should be within +2 percent of each other.
- j. If the percentage does not fall within the +2 percent tolerance, adjust PLATE CURRENT METER TRACK potentiometer 1A7R1 slightly. Refer to figure 3-2 for location of 1A7R1.
- k. Repeat steps h., i., and j. until the +2 percent tolerance is achieved.

NOTE

When remote meters are installed or removed, it may be necessary to repeat the calibrations and adjustments.

- l. Depress HIGH VOLTAGE OFF pushbutton switch.
- m. Depress FILAMENT OFF pushbutton switch.
- n. Open right rear transmitter door.

**WARNING**

USE GROUNDING HOOK TO DISCHARGE ANY RESIDUAL POTENTIAL FROM ALL EXPOSED COMPONENTS BEFORE TOUCHING THEM.

- o. Disconnect the test meter.
- p. Close and latch the right rear transmitter door.

2-43. REMOTE PA PLATE VOLTAGE METER SAMPLE CALIBRATION

2-44. The following is a procedure to accomplish the adjustment of a Plate Volt meter installed in a location remote from the transmitter.

- a. Connect a meter, 10k ohm/volt or greater, that has a scale-range that is compatible with the PA PLATE VOLTS meter, located on the right-hand meter panel, to terminal 19 and terminal 3 (chassis ground).
- b. Adjust TRACKING potentiometer 1A2A2R23 to midrange. Refer to figure 3-9 for location of 1A2A2R23.
- c. Operate the transmitter at high-power output (5 kW).
- d. Adjust CALIBRATE potentiometer 1A2A2R24 until the reading displayed on the PA PLATE VOLTS meter matches the reading displayed on the remote meter. Refer to figure 3-9 for location of 1A2A2R24.
- e. Operate the transmitter at low power (1 kW).
- f. Adjust TRACKING potentiometer 1A2A2R23 until the reading displayed on the PA PLATE VOLTS meter matches the reading displayed on the remote meter.
- g. Repeat steps c., d., e., and f. until the meter readings are within +5 percent when transmitter is operated at either high or low power.
- h. Depress the HIGH VOLTAGE OFF pushbutton switch.
- i. Depress the FILAMENT OFF pushbutton switch.
- j. Disconnect the remote meter.

2-45. REMOTE  $E_p$ - $I_p$  CALIBRATION

- a. With remote connected to terminal 11 on terminal board 1TB2 (located on the cabinet floor next to the blower inlet), activate transmitter to operate at high power (5 kW).
- b. Adjust remote  $I_p$  potentiometer as required so that remote current meter indicates the same as transmitter current meter.
- c. Switch between high and low power outputs and continue to adjust the remote  $I_p$  potentiometer until the meters track within +2 percent of each other.
- d. Adjust potentiometer 1A2A2R24 to midrange and adjust remote  $E_p$  potentiometer to midrange.
- e. Operate transmitter for high-power output and adjust remote  $E_p$  potentiometer such that remote meter indicates same reading as the transmitter voltage meter. If unable to adjust remote meter, adjust 1A2A2R24 counterclockwise then adjust remote  $E_p$  potentiometer.
- f. Continue to calibrate fixture  $E_p$  meter with the fixture  $E_p$  potentiometer at high power and adjust 1A2A2R23 to track fixture meter at low power until accuracy is within +5 percent from high to low power.
- g. Momentarily activate remote OFF control and verify that both remote meters momentarily indicate zero.

## SECTION III

### OPERATION

#### 3-1. INTRODUCTION

3-2. This section contains information pertaining to the identification, location, and function of the controls and indicators on the HARRIS MW-5B AM BROADCAST TRANSMITTER. The procedures and test equipment required to set up and operate the transmitter are also presented.

#### 3-3. CONTROLS AND INDICATORS

3-4. Figures 3-1 through 3-9 show the locations of the controls and indicators on the transmitter. Tables 3-1 through 3-9 list these controls and indicators.

#### 3-5. OPERATING PROCEDURE

#### CAUTION

THE OPERATIONAL/BYPASS SWITCH, 1A1A4S1 SHOULD NEVER BE OPERATED (IN OR OUT) WHILE A PROGRAM IS OPERATING OVER THE AIR. THIS SWITCH IS USED TO PUT THE MODULATION ENHANCER IN OR OFF LINE AND CAUSES A 6 DB CHANGE IN MODULATION (OVERMODULATION IF SWITCHED TO BYPASS, UNDERMODULATION IF SWITCHED TO OPERATIONAL). THE OPERATOR MUST CHANGE THE MODULATION LEVEL AT THE AUDIO INPUT TERMINALS OF THE TRANSMITTER ACCORDING TO THE SETTING OF THE SWITCH. ADD 6 DB WHEN SWITCHING TO THE OPERATIONAL POSITION. REMOVE 6 DB WHEN SWITCHING TO THE BYPASS POSITION.

3-6. This operating procedure is presented under the assumption that the transmitter has been thoroughly and properly aligned at the desired operating frequency and is free of any discrepancies. Perform the operating procedure as follows:

- a. Visually inspect the transmitter to ensure that no foreign objects are inside the cabinet, all parts and components are properly installed, all connectors are seated, all grounding sticks are on their respective interlock hooks, and all doors are closed.
- b. Apply primary power (60-ampere service).



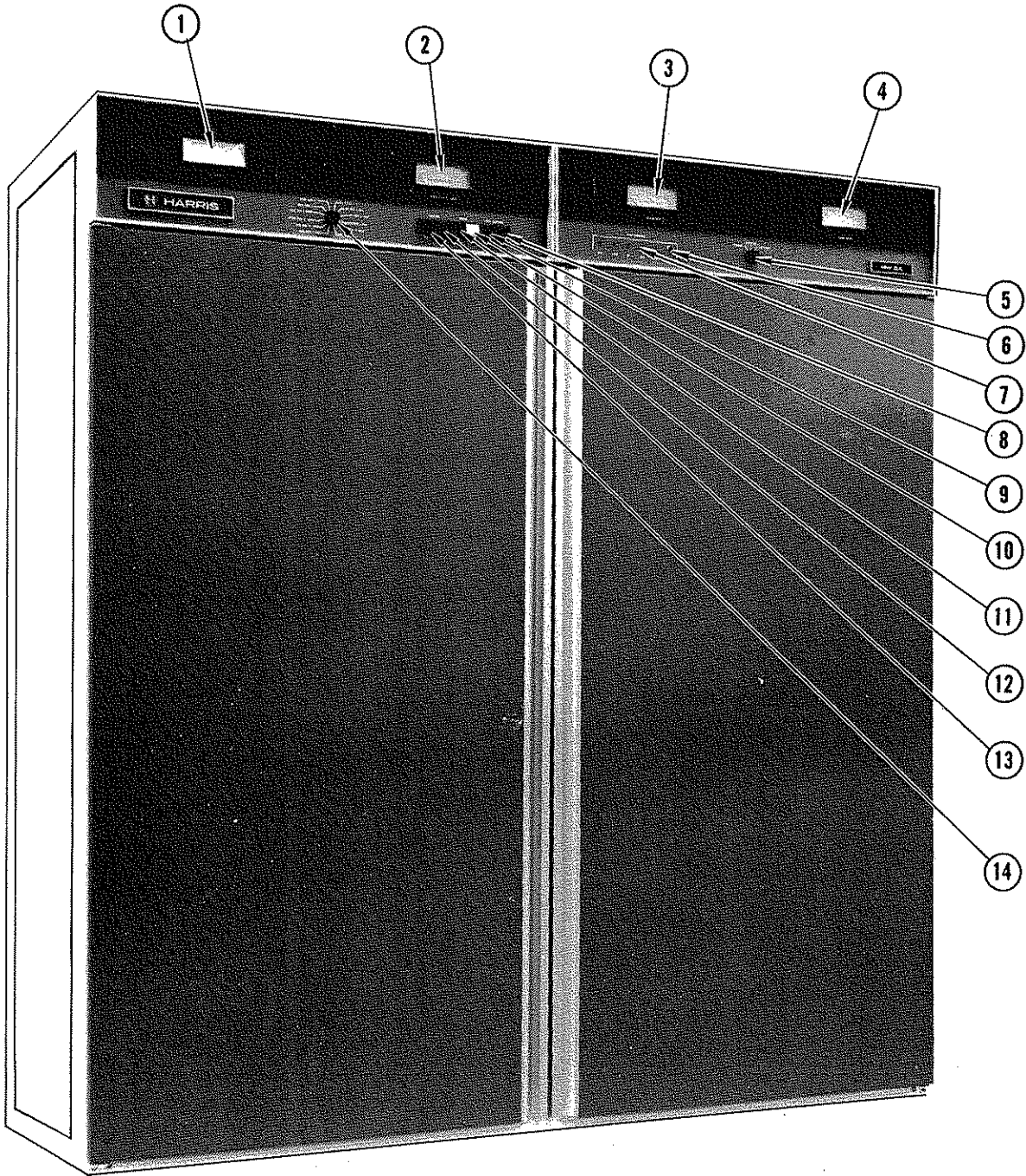

Figure 3-1. External Meter and Control Panels 1A7 and 1A9, Controls and Indicators

Table 3-1. External Meter and Control Panels 1A7 and 1A9, Controls and Indicators

REF.	CONTROL/INDICATOR	FUNCTION
Fig. 3-1		
1	MULTIMETER 1A7M1	Displays the voltage or current selected by MULTIMETER switch 1A7S7.
2	REMOTE PA PLATE CURRENT Meter 1A7M2	Permits monitoring of PA plate current when cabinet front doors are closed.
3	PA PLATE VOLTS Meter 1A9M1	Indicates voltage across PA tube.
4	POWER OUTPUT Meter 1A9M2	Indicates forward power, reflected power, or relative efficiency as selected by 1A9S2.
5	FORWARD/REFLECTED/ EFFICIENCY Power Meter Switch 1A9S2	Selects forward power, reflected power, or relative efficiency for display on POWER OUTPUT meter.
6	RESET Switch 1A9S1	When depressed, extinguishes all FAULT INDICATORS.
7	FAULT INDICATORS	
	ARC Indicator 1A9DS1	Illuminates when arc gap 1E3, 1E4, or 1E5 fires.
	VSWR Indicator 1A9DS2	Illuminates when transmitter has cycled because of a change in VSWR.
	DC Indicator 1A9DS3	Illuminates when step start resistor overload is sensed or high voltage power supply current exceeds preset level.
	DISS Indicator 1A9DS4	Illuminates to indicate a change in ratio of output to input power.
	MOD Indicator 1A9DS5	Illuminates to indicate a screen overload in modulation tube.

Table 3-1. External Meter and Control Panels 1A7 and 1A9,  
Controls and Indicators (Continued)

REF.	CONTROL/INDICATOR	FUNCTION
Fig. 3-1		
8	HIGH VOLTAGE OFF Switch 1A7S6	When depressed, deactivates high-voltage circuits.
9	HIGH VOLTAGE ON Switch/Indicator 1A7S5	When depressed, activates high-voltage circuits; switch indicator illuminates green.
10	POWER HIGH Switch/Indicator 1A7S4	When depressed, switches transmitter to high-power condition; switch/indicator illuminates yellow.
11	POWER LOW Switch/Indicator 1A7S3	When depressed, switches transmitter to low-power condition; switch/indicator illuminates blue.
12	FILAMENT ON Switch/Indicator 1A7S2	When depressed, starts blower motor and activates filaments; switch/indicator illuminates green.
13	FILAMENT OFF Switch 1A7S1	When depressed, deenergizes entire transmitter.
14	MULTIMETER Switch 1A7S7	Selects the desired monitoring point for display on MULTIMETER M1.

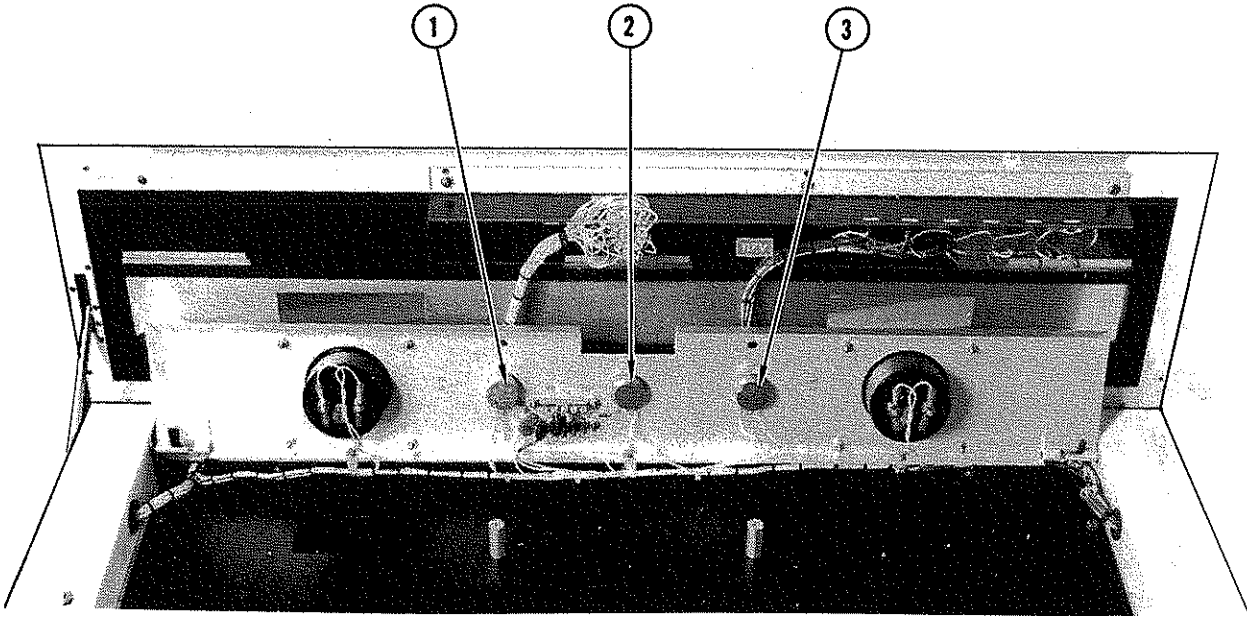

Figure 3-2. Meter Panel 1A7 Controls

888-2109-010

3-5

**WARNING:** Disconnect primary power prior to servicing.

Table 3-2. Meter Panel 1A7 Controls

REF.	CONTROL/INDICATOR	FUNCTION
Fig. 3-2		
1	PLATE CURRENT METER TRACK Variable Resistor 1A7R1	Adjusts to calibrate REMOTE PA PLATE CURRENT meter for high-power output.
2	PLATE CURRENT METER CAL Potentiometer 1A7R4	Adjusts to calibrate REMOTE PA PLATE CURRENT meter for low-power output.
3	FILAMENT VOLTAGE METER CAL Potentiometer 1A7R8	Adjusts MULTIMETER to indicate 100 per- cent when modulator and power amplifier filament voltage is correct.

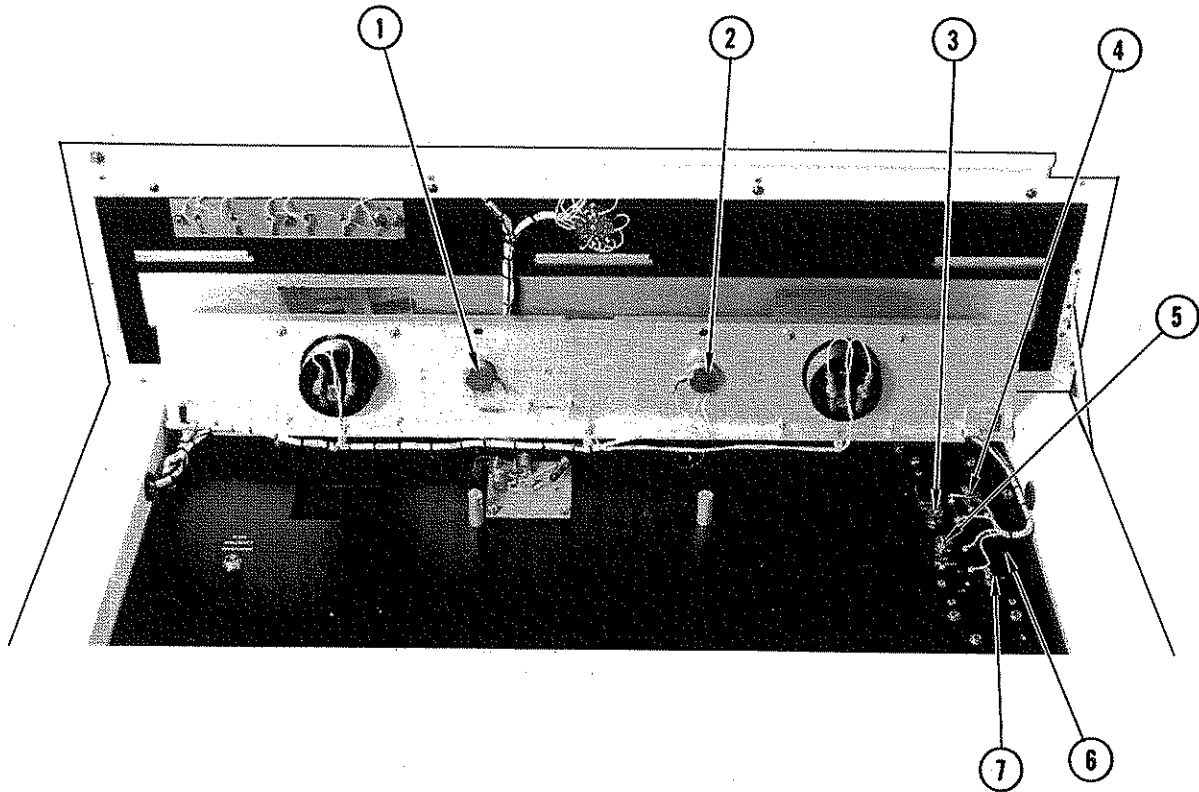

Figure 3-3. Meter Panel 1A9 and Directional Coupler 1A8 Controls

888-2109-010

3-7

**WARNING:** Disconnect primary power prior to servicing.

Table 3-3. Meter Panel 1A9 and Directional Coupler 1A8 Controls

REF.	CONTROL/INDICATOR	FUNCTION
Fig. 3-3		
1	PLATE VOLTAGE METER ELECTRICAL ADJUST Potentiometer 1A9R1	Adjusts PA PLATE VOLTS meter to electrical zero.
2	EFFICIENCY METER ADJUST Potentiometer 1A9R4	Adjusts POWER OUTPUT meter to relative operational reference.
	<u>Directional Coupler</u> <u>1A8</u>	
3	REFLECTED CALIBRATE Potentiometer 1A8R2	Adjusts POWER OUTPUT meter for accurate indication of reflected power.
4	C3 Variable Capacitor 1A8C3	Adjusts reflected voltage sample to equal reflected current sample.
5	FWD CALIBRATE Potentiometer 1A8R7	Adjusts POWER OUTPUT Meter for accurate indication of forward power.
6	Power Out Sample (not marked)	Provides test point to verify presence of transmitter output (sample voltage is approximately 5 to 10V p-p).
7	C9 Variable Capacitor 1A8C9	Adjusts forward voltage sample to equal forward current sample.

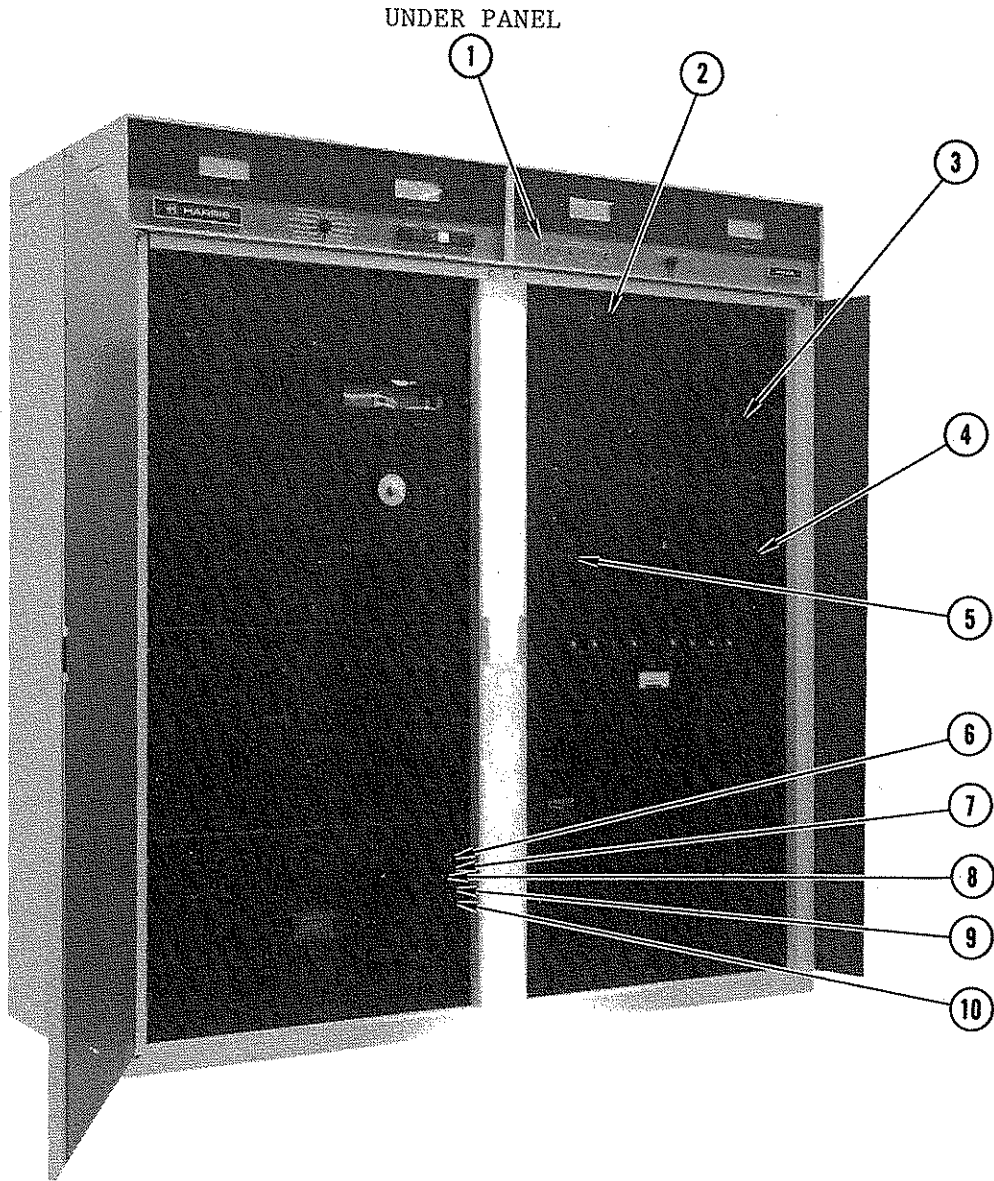

Figure 3-4. Carrier Tuning Controls And HV Protection Controls And Indicators



Table 3-4. Carrier Tuning Controls And HV Protection Controls And Indicators

REF.	CONTROL/INDICATOR	FUNCTION
Fig. 3-4		
1	PLATE EFFICIENCY RESONATOR Variable Inductor 1L5	Adjusts power amplifier plate waveform to most efficient operating shape (peak efficiency reading on POWER OUTPUT meter).
2	PA TUNE Variable Capacitor 1C14	Adjusts PA plate circuit to carrier frequency resonance (is tuned for minimum plate current).
3	PA LOAD Variable Inductor 1L13	Adjusts the required carrier level output (normally 1.2 ampere $I_p$ ).
4	2nd HARMONIC TRAP Variable Inductor 1L12	Adjusts to minimize 2nd harmonic radiation
5	3rd HARMONIC TRAP Variable Inductor 1L9	Adjusts to minimize 3rd harmonic radiation.
6	GROUND TEST POINT TP3	Test point 3. Connected to transmitter ground.
7	HIGH VOLTAGE FAULT LED DS1	Illuminates when the 100/120 Hz ripple content of the HV Power Supply has exceeded its preset level.
8	GAIN ADJUST Potentiometer R7	Sets the trip sensitivity of the HV Protection circuitry.
9	TEST POINT TP1	Test point for the HV Power Supply filtered ripple signal.
10	TEST POINT TP2	Test point for the HV Power Supply peak detected ripple signal.

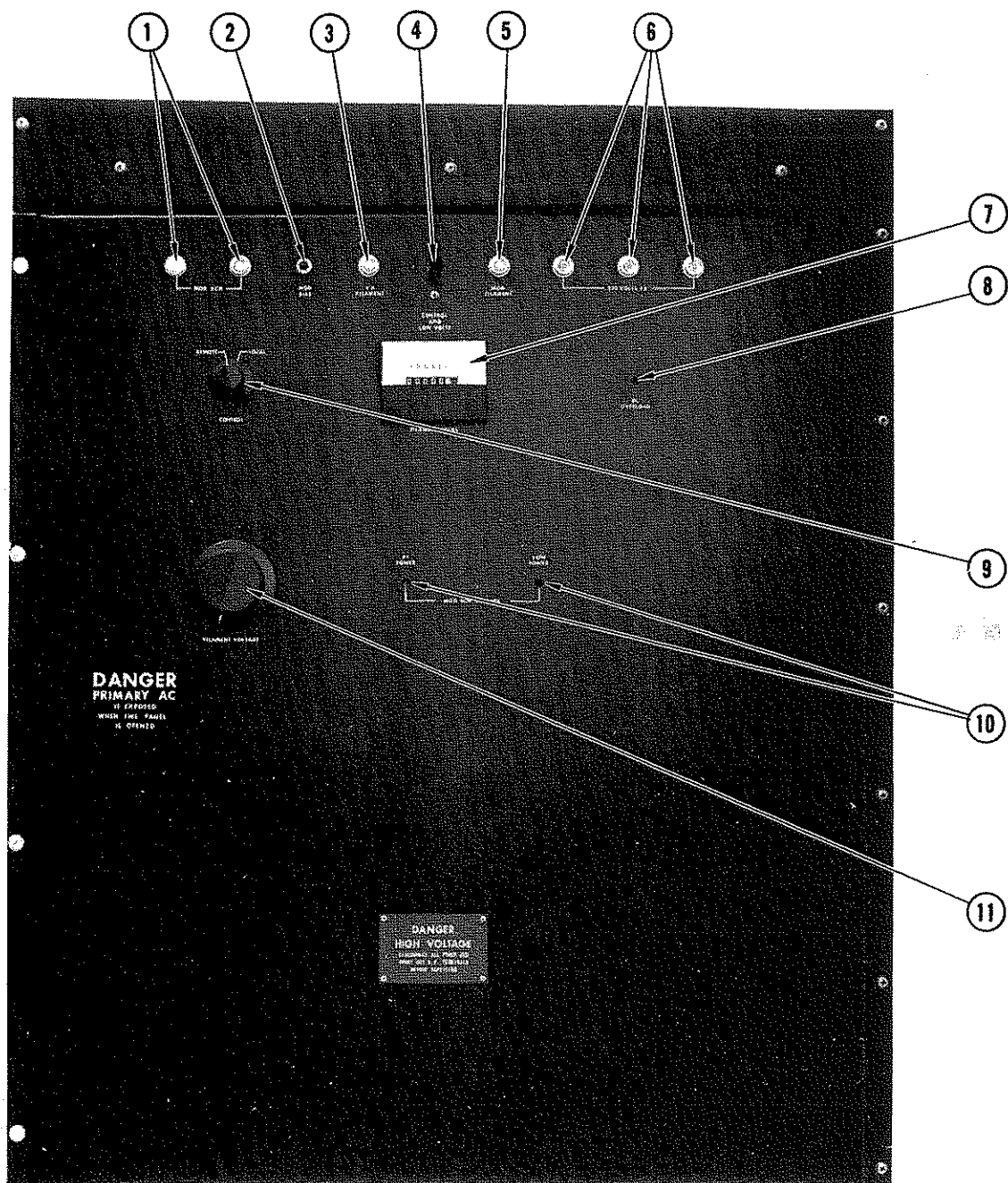

Figure 3-5. AC Power Panel 1A4 Controls and Indicators

Table 3-5. AC Power Panel 1A4 Controls and Indicators

REF.	CONTROL/INDICATOR	FUNCTION
Fig. 3-5		
1	MOD SCN 2-ampere Circuit Breakers 1A4CB8 and 1A4CB9	Provides protection for screen supply 1A11 overloads.
2	MOD BIAS 0.1-ampere Circuit Breaker 1A4CB7	Provides protection for modulator bias supply 1A5 overloads.
3	PA FILAMENT 3-ampere Circuit Breaker 1A4CB6	Provides protection for power amplifier filament circuit overloads.
4	CONTROL AND LOW VOLTS 5-ampere Circuit Breaker 1A4CB5	Provides protection for control circuit overloads and for low-voltage power supply 1A5 overloads.
5	MOD FILAMENT 3-ampere Circuit Breaker 1A4CB4	Provides protection for modulator fila- ment circuit overloads.
6	230 VOLTS 3Ø 15-ampere Circuit Breakers 1A4CB1, CB2, CB3	Provide protection for each phase of 3- phase circuit (exclusive of high-volt- age supply).
7	FILAMENT HOURS Meter 1A4M1	Displays cumulative time that tube filaments are energized.
8	DC OVERLOAD Variable Resistor 1A4R9	Adjusts the trip point at which high voltage is recycled or shut off because of high-current drain on high-voltage supply.
9	CONTROL Switch 1A4S1	Selects either LOCAL or REMOTE control of transmitter.
10	MOD SCN VOLTAGE  HI POWER Variable Resistor 1A4R10	Adjusts modulator screen voltage when operating in high-power mode. Full adjustment provides <u>+20</u> percent change.

Table 3-5. AC Power Panel 1A4 Controls and Indicators (Continued)

REF.	CONTROL/INDICATOR	FUNCTION
Fig. 3-5	<p>LOW POWER Variable Resistor 1A4R5</p>	<p>Adjusts modulator screen voltage when operating in low-power mode. Full range adjustment provides <u>+15</u> percent change.</p>
11	<p>FILAMENT VOLTAGE Variable Resistor 1A4R4</p>	<p>Adjusts filament voltage of power amplifier tube and modulator tube.</p>

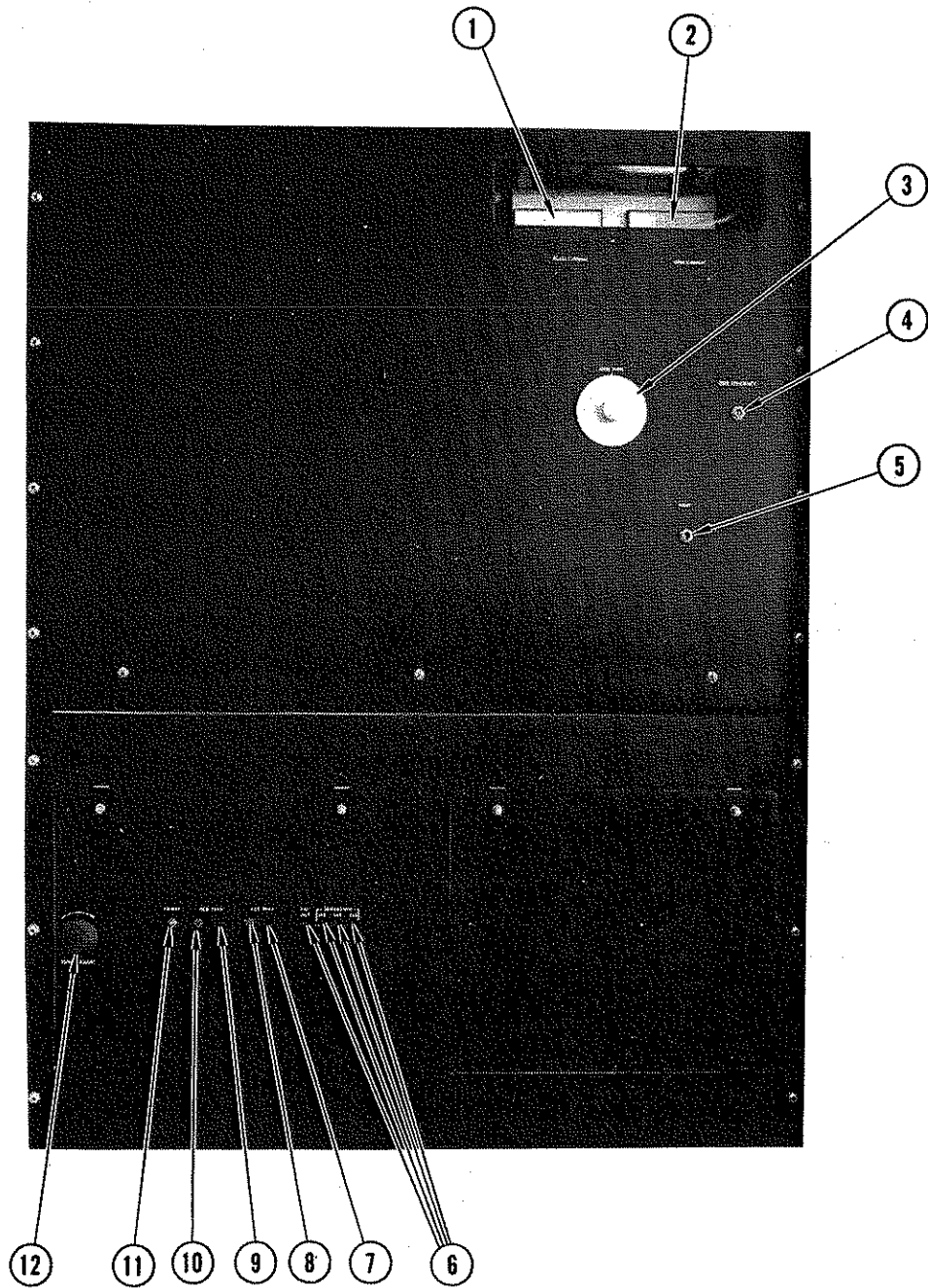

Figure 3-6. Isolated Plate 1A3, Modulation Enhancer 1A1A4, and Fine Power Adjust Controls and Indicators

Table 3-6. Isolated Plate 1A3, Modulation Enhancer 1A1A4, and Fine Power Adjust, Controls and Indicators

REF.	CONTROL/INDICATOR	FUNCTION
Fig. 3-6	<u>Isolated Plate 1A3</u>	
1	PLATE CURRENT Meter 1A3M1	Indicates total current through power amplifier.
2	GRID CURRENT Meter 1A3M2	Indicates total grid current through power amplifier.
3	GRID TUNE Variable Capacitor 1A3C1	Adjusts power amplifier grid circuit to carrier frequency resonance (maximum power amplifier grid current).
4	GRID EFFICIENCY Variable Capacitor 1A3C2	Adjusts power amplifier grid waveforms to most efficient operating shape (minimum voltage on PA PLATE VOLTS meter).
5	NEUT Variable Capacitor 1A3C3	Adjusts to minimize power amplifier grid-to-plate capacitance.
	<u>Modulation Enhancer 1A1A4</u>	
6	CAL OUT - ENHANCING 1 dB/2 dB/3 dB Switch Assembly 1A1A4S1	CAL OUT position: permits initial set-up without enhancement. ENHANCING 1 dB, 2 dB or 3 dB position: selects amount of enhancement from 1 dB (minimum) to 3 dB (maximum) in 1 dB increments.
7	POS PEAK Potentiometer 1A1A4R20	Permits adjustment of the threshold for positive clipping.
8	POS PEAK Indicator 1A1A4DS3	Illuminates when enhancer is clipping positive peaks.
9	NEG PEAK Potentiometer 1A1A4R16	Permits adjustment of the threshold for negative clipping.
10	NEG PEAK Indicator 1A1A4DS2	Illuminates when enhancer is clipping negative peaks.

Table 3-6. Isolated Plate 1A3, Modulation Enhancer 1A1A4, and Fine Power Adjust, Controls and Indicators (Continued)

REF.	CONTROL/INDICATOR	FUNCTION
Fig. 3-6		
11	POWER Indicator 1A1A4DS1	Illuminates to indicate that enhancer power supply circuit is operating.
12	<u>Fine Power Adjust</u> POWER ADJUST Motor-Driven Potentiometer 1A1R2	Adjusts for minor changes (fine tuning) of power output.

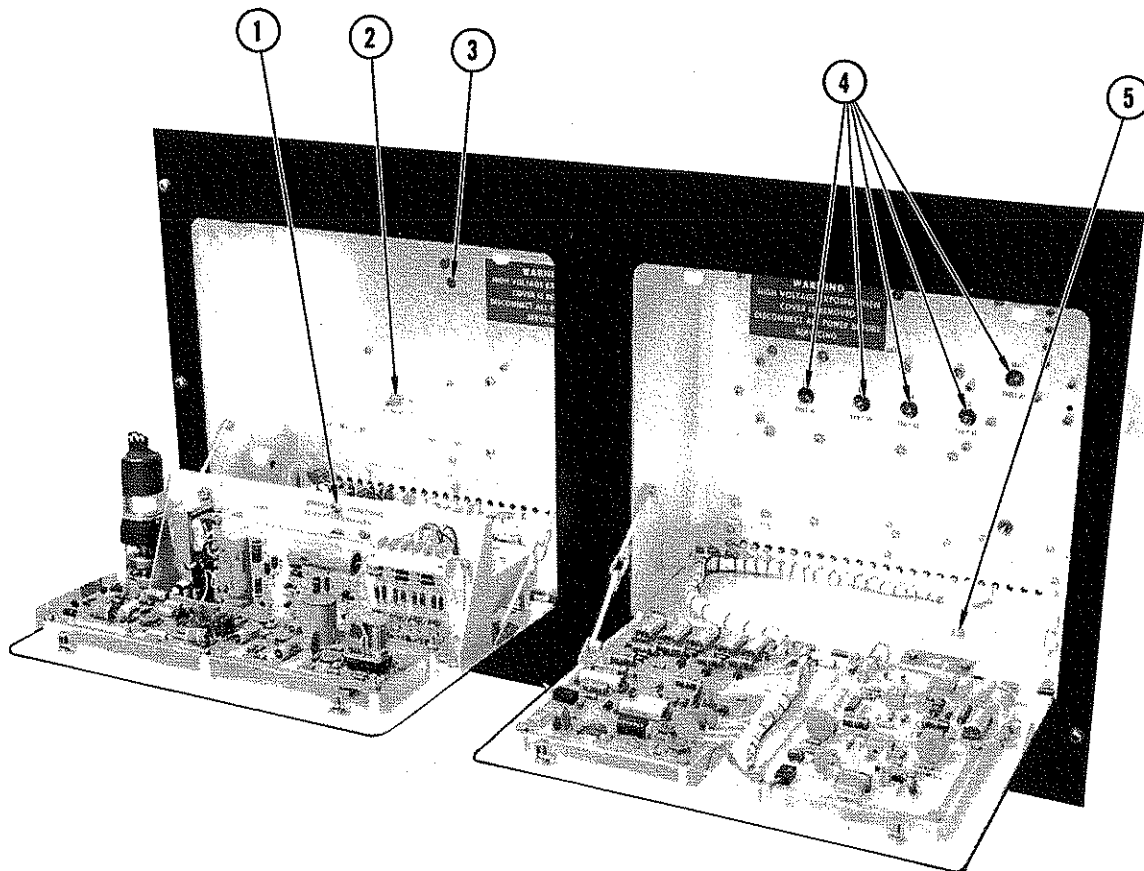

Figure 3-7. PDM Chassis 1A1 and RF Driver and Overload 1A2 Controls and Indicators



Table 3-7. PDM Chassis 1A1 and RF Driver and Overload 1A2, Controls and Indicators

REF.	CONTROL/INDICATOR	FUNCTION
<p>Fig. 3-7</p> <p>1</p>	<p>OPERATIONAL/BYPASS Switch 1A1A4S1</p>	<p>OPERATIONAL position: connects audio input to enhancer and connects enhanced output to the audio input and overload module circuit.</p> <p>BYPASS position: bypasses Modulation Enhancer so that audio input is routed directly to the audio input and overload module circuit.</p>
<p>2</p>	<p>AUX MOD ADJUST Potentiometer 1A1R3</p>	<p>Adjusts for optimum drive conditions as required at modulator grid.</p>
<p>3</p>	<p>AUX DRIVER ADJUST Potentiometer 1A1A3R8</p>	<p>Adjusts for optimum current conditions as required at modulator grid.</p>
<p>4</p>	<p>FAULT A1 through FAULT A5 Indicators 1A2A3DS2 through DS5</p>	<p>Illuminate to indicate malfunction or improper adjustment of associated rf module.</p>
<p>5</p>	<p>IPA OUTPUT ADJUST Potentiometer 1A2A3R4</p>	<p>Provides limited control of IPA supply voltage (RF Drive).</p>

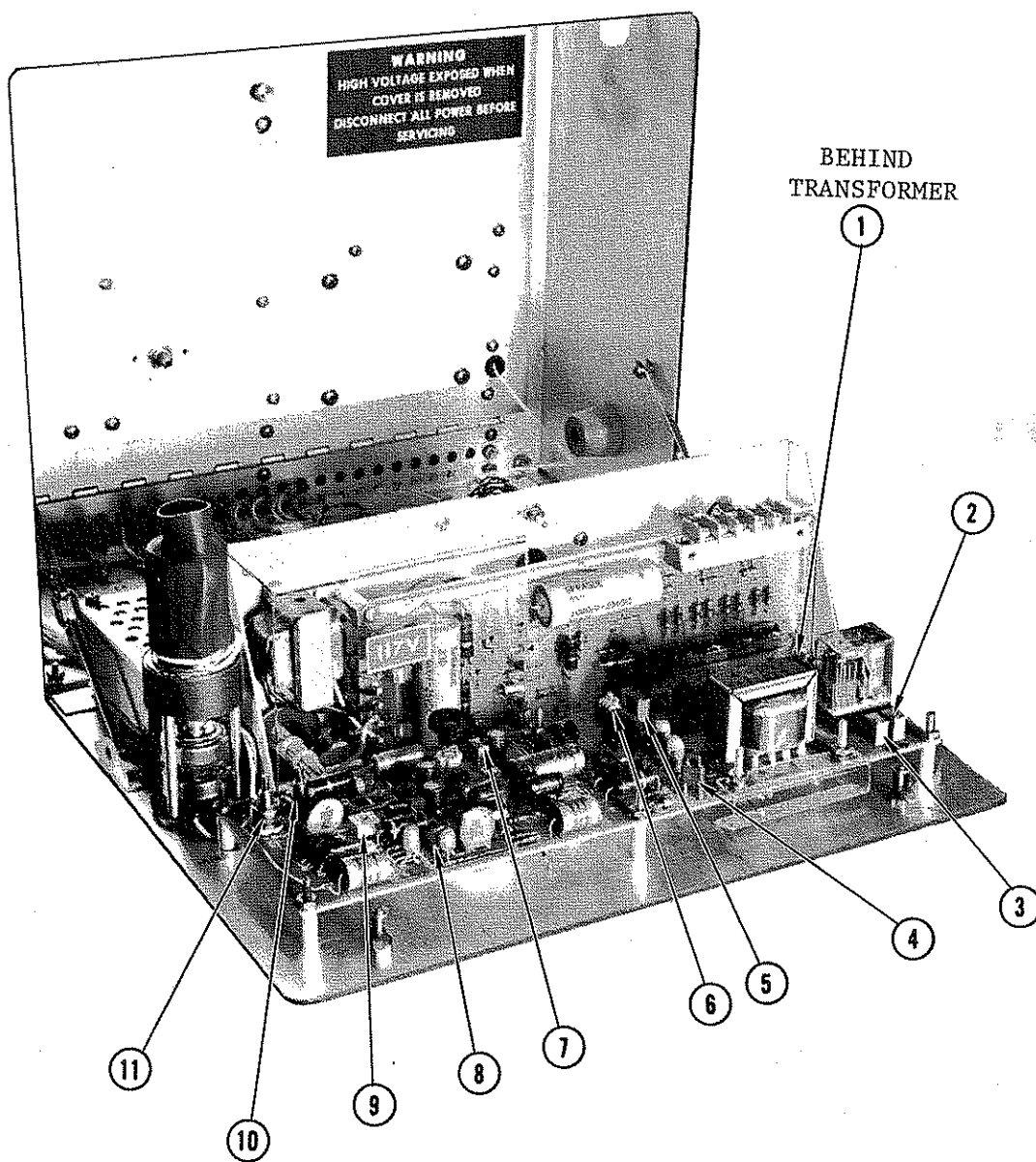

Figure 3-8. PDM Chassis 1A1 Controls and Indicators

Table 3-8. PDM Chassis 1A1, Controls and Indicators

REF.	CONTROL/INDICATOR	FUNCTION
Fig. 3-8		
1	INPUT GAIN Potentiometer 1A1A2R11	Provides adjustment for 100% modulation audio input level from 0 dBm to +10 dBm.
2	MODULATION TRACKING Potentiometer 1A1A2R41	Adjusts modulation tracking circuitry for best linearity.
3	LOW PWR AUDIO Potentiometer 1A1A2R42	Adjusts to provide low-power audio input at same level as high-power audio input.
4	Jack 1A1A2J1	Jumper position adjusts hum phase. Jumper to be positioned for greatest signal-to-noise ratio.
5	CMRR Potentiometer 1A1A2R66	Adjusts input amplifier common-mode rejection ratio at low frequencies.
6	BESSEL FILTER IN/OUT Switch 1A1A2S1	Allows Bessel low-pass filter to be inserted in audio input circuitry for overshoot reduction and anti-aliasing protection.
7	HUM NULL Potentiometer 1A1A2R29	Potentiometer R29 adjusts hum injection level. Potentiometer is to be adjusted for greatest signal-to-noise ratio.
8	CARRIER SHIFT Potentiometer 1A1A2R35	Adjusts to provide minor feedback corrections for shift of carrier during modulation.
9	DISS Potentiometer 1A1A2R38	Adjusts to set reference point at which overload occurs due to change between input power and output power.
10	HI PWR Potentiometer 1A1A2R52	Adjusts rf carrier output from 0 to 5500 watts when operating in the high-power mode.

Table 3-8. PDM Chassis 1A1, Controls and Indicators (Continued)

REF.	CONTROL/INDICATOR	FUNCTION
<p>Fig. 3-8</p> <p>11</p>	<p>LO PWR Potentiometer 1A1A2R53</p>	<p>Adjusts rf carrier output when operating in the lower power mode.</p>

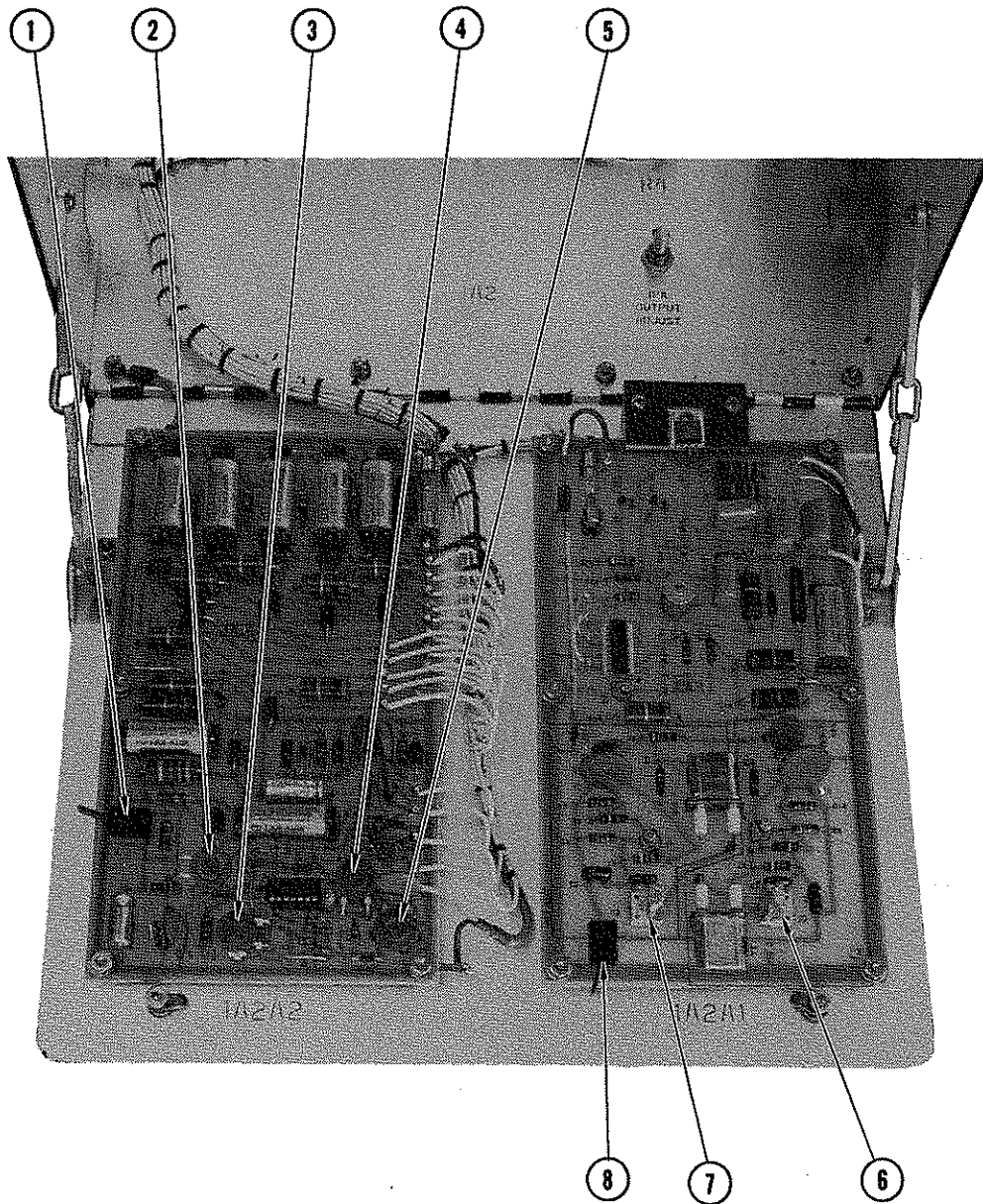

Figure 3-9. RF Driver and Overload 1A2 Controls and Indicators

Table 3-9. RF Driver and Overload 1A2, Controls and Indicators

REF.	CONTROL/INDICATOR	FUNCTION
Fig. 3-9		
1	RECYCLE OFF/ON Switch 1A2A2S1	OFF Position: Causes immediate high-voltage shutdown when overload occurs.  ON Position: When overload occurs, attempts to recycle transmitter on three or four times before high-voltage shutdown.
2	R24 Potentiometer 1A2A2R24	Adjusts to calibrate remote $E_p$ meter.
3	R23 Potentiometer 1A2A2R23	Adjust tracking range.
4	R26 Potentiometer 1A2A2R26	Adjusts to set threshold of operational amplifier 1A2A2U1.
5	R32 Potentiometer 1A2A2R32	Adjusts VSWR overload threshold.
6	C7 Variable Capacitor 1A2A1C7	Adjusts to trim-carrier frequency of oscillator #2.
7	C1 Variable Capacitor 1A2A1C1	Adjusts to trim-carrier frequency of oscillator #1.
8	S1 Switch 1A2A1S1	Selects oscillator 1 or 2 for operation.

#### NOTE

If a Remote Control is part of the transmitter system, set the CONTROL LOCAL/REMOTE switch to the REMOTE position and perform the remaining steps except for step c.

- c. Set the CONTROL LOCAL/REMOTE switch to the LOCAL position.
- d. Lower the access door to the overload board and ensure that RE-CYCLE switch is in the ON position. This allows for three over-voltage transmitter overloads within a 30-second period prior to shutdown.
- e. Set CONTROL AND LOW VOLTS circuit breaker CB5 to ON position.
- f. Operate the OPERATIONAL/BYPASS switch to the desired position.
- g. Depress FILAMENT ON pushbutton switch. The indicator immediately illuminates to indicate that all internal and external interlocks are closed, the control circuit breakers are closed, and the blower is operating. Allow a 30-second warmup interval.
- h. Depress the POWER HIGH or POWER LOW pushbutton switch for the desired output power.
- i. Depress the HIGH VOLTAGE pushbutton switch. The transmitter is now operating at the selected power output.

#### 3-7. MODULATION ENHANCER

3-8. If modulation enhancement is desired, set the OPERATIONAL/BYPASS switch to OPERATIONAL. Adjust the Modulation Enhancer as follows:

- a. Depress the CAL OUT pushbutton switch.
- b. Modulate the transmitter with typical music. Set the AGC and limiter for normal operation. Set the limiter for 125 percent modulation.
- c. Operate the AGC and limiter as suggested in their respective Technical Manuals. Adjust the limiter for maximum legal modulation of the transmitter.

#### NOTE

The desired amount of enhancing can only be determined by listening to the output. The more enhancing (3 dB maximum) the louder the signal.

- d. Depress the ENHANCING 1 dB, 2 dB, or 3 dB switch and adjust the NEG PEAK (potentiometer R16) and POS PEAK (potentiometer R20) controls for maximum negative and positive peaks without overmodulating.





## SECTION IV

### PRINCIPLES OF OPERATION

#### 4-1. GENERAL

4-2. This section presents the principles of operation for the HARRIS MW-5B AM BROADCAST TRANSMITTER at two levels. The first level explains the theory of the transmitter on a block diagram basis, and the second level provides a detailed description of circuits.

#### 4-3. OVERALL FUNCTIONAL DESCRIPTION

4-4. The MW-5B AM BROADCAST TRANSMITTER utilizes redundant circuitry of modular construction. The MW-5B AM BROADCAST TRANSMITTER consists of four basic subsystems; RF, Audio, Control, and Equipment/Personnel Protection. The following discussion references block diagram figure 4-1.

#### 4-5. RF SUBSYSTEM

4-6. The RF Subsystem includes the Oscillator board, Intermediate Power Amplifier (IPA) module, four RF Driver modules, and the Power Amplifier tube (3CX2500F3). The oscillator generates a stable rf signal from which the carrier frequency is derived. The IPA isolates the oscillator for improved frequency stability and, in conjunction with the RF Drivers, amplifies the rf signal to efficiently drive the power amplifier tube. The power amplifier (PA) increases the power of the rf signal to the rated output level radiated by the antenna. The output network consists of conventional L sections and provides 225 degrees of phase-shift which reduces interaction between plate and loading controls during tune-up.

#### 4-7. AUDIO SUBSYSTEM

4-8. The Audio Subsystem includes the Modulation Enhancer, Audio Input Circuit located on the PDM control and feedback board, PDM Board, Audio Driver, the Modulator Tube, and the 75 kHz Filter.

4-9. The Modulation Enhancer consists of an isolation pad, an isolation transformer, and positive and negative adjustable clipper circuits. The Audio Input Circuits consists of an isolation pad, a balanced-to-unbalanced transformer, and one stage of amplification.

4-10. The Audio Input circuit consists of a resistive pad, an RFI filter, and a differential amplifier. A low-pass Bessel filter may be enabled to reduce complex wave overshoots. A modulation tracking circuit controls audio input level with changing carrier level, providing constant modulation percentage regardless of transmitter power output. On the PDM board, the PDM 75 kHz signal is pulse-width modulated from the amplified audio. The Audio Driver amplifies the low-level output of the PDM board to the voltage level required to efficiently drive the Modulator tube. The Modulator tube is a conventional tube which amplifies the audio-driver output to modulate the Power Amplifier tube. The 75 kHz filter removes the PDM frequency,

leaving the audio to modulate the power amplifier. The damper diode string is connected between the plate of the Modulator tube and the High-Voltage Power Supply. Should the voltage at the plate of the Modulator tube attempt to exceed the supply voltage, the Damper Diode string will conduct the current back to the power supply. When the Modulator tube is not conducting, the Damper Diode string conducts. Conversely, when the Modulator tube conducts, the Damper Diode string is shut off.

#### 4-11. CONTROL SUBSYSTEM

4-12. The control subsystem provides switches and relays which control the application of primary power to all internal power supplies. Included are a LOCAL/REMOTE switch, FILAMENT OFF/ON, HIGH VOLTAGE OFF/OF, HIGH and LOW POWER pushbutton switches, and the CONTROL and LO VOLTS circuit breaker.

#### 4-13. PERSONNEL AND EQUIPMENT PROTECTION SUBSYSTEM

4-14. This subsystem includes the following circuits and devices for the protection of personnel and transmitter equipment:

- a. Safety interlock.
- b. DC overload.
- c. Dissipation limiter overload.
- d. Modulator screen overload.
- e. VSWR overload.
- f. Step start overload.
- g. Overload counter and turn off.
- h. Air interlock.
- i. High-Voltage transformer imbalance overload.

#### 4-15. SAFETY INTERLOCK CIRCUIT

4-16. All front and rear access doors are equipped with interlock switches which disable the transmitter when any access door is opened. When an access door is open, the transmitter is completely turned off and all dangerous high-voltage storage areas are grounded.

#### 4-17. DC OVERLOAD

4-18. The DC Overload circuit senses the current on the secondary side of the high-voltage power supply. When the current from the supply exceeds a predetermined value (approximately 0.80 amperes at 20 Hz), the dc overload causes the transmitter high voltage to recycle and a pulse is routed to the counter circuit. If more than three overloads occur within a 30-second

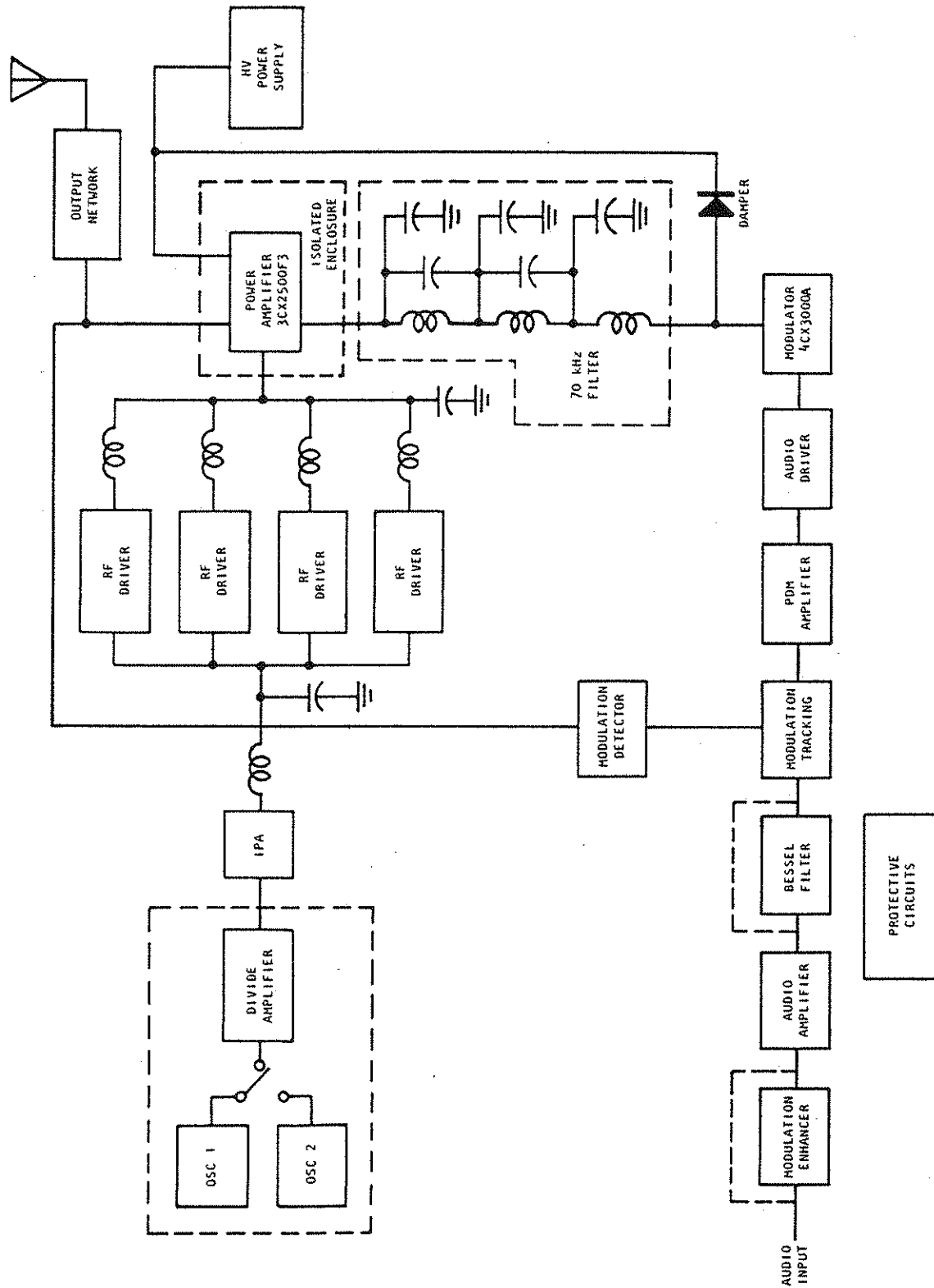

Figure 4-1. MW-5B AM BROADCAST TRANSMITTER Overall Block Diagram

period, the high voltage is shut off. If the overloads occur more slowly (for example, one every 30-seconds during an electrical storm) the transmitter will continue to recycle automatically.

#### 4-19. DISSIPATION OVERLOAD

4-20. The Dissipation Limiter senses a change in the ratio of power out to power in. Should the input power to the transmitter increase (supply current) but the output power not follow, the modulator is tuned off, causing the power amplifier plate voltage to cut off. With plate voltage off, the rf output power drops to zero. The recycle system is the same as with dc overloads.

#### 4-21. MODULATOR SCREEN OVERLOAD

4-22. The Modulator Screen Overload senses the current drawn from the screen grid of the modulator tube. The overload condition causes the same sequence of events as the Dissipation Overload.

#### 4-23. VSWR OVERLOAD CIRCUIT

4-24. The transmitter includes a Directional Coupler that senses a VSWR change. If the impedance of the antenna system changes by more than 10 percent, the following action will take place. The PDM signal is removed from the modulator grid, thus turning off the modulator tube and causing the power amplifier plate voltage to cut off. With the plate voltage off, the rf output power drops to zero. The recycle sequence is the same as with dc overloads.

#### 4-25. STEP-START OVERLOAD

4-26. This circuit consists of relay 1A4A1K4 and associated circuitry located on the printed-circuit board which is mounted on the back of AC Power Panel 1A4. If a short occurs in the High-Voltage Power Supply or high-voltage circuits during the step-start sequence, the step-start overload circuit senses an over-current condition in step-start resistor 1A4A1R8. The circuit removes the high voltage within a few milliseconds to prevent damage to the step-start resistors.

#### 4-27. OVERLOAD COUNTER AND TURN OFF CIRCUIT

4-28. Located on the Fault and Overload board, this circuit consists of relay K7, switch S1, capacitors C1 and C2, and associated components. The function of this circuit is to count the impulses from the various overload circuits and cause the high voltage to shut off.

#### 4-29. AIR INTERLOCK SWITCH

4-30. The Air Interlock Switch is a diaphragm-operated microswitch that senses the air pressure from the blower. If the blower does not operate when the transmitter FILAMENT ON pushbutton switch is depressed, the filament and low voltage will not stay on. Because the air cooling is more than adequate,

turbulence in the air should not cause an interruption in transmitter operation. If the PA rear cover is removed while the transmitter is in operation, the transmitter will shut down immediately.

#### 4-31. HV TRANSFORMER FAULT

4-32. The transmitter contains a high-voltage transformer protection circuit which senses transformer phase imbalances. Gross phase imbalances can result in intense localized heating. A high-voltage sample is taken at the 7 kV node and passed through a 90-130 Hz bandpass filter. Phase imbalances cause an increased noise component at a frequency that is two times the power line frequency. If the peak level of this signal exceeds the preset threshold, the transmitter will be shut down and the DC OVERLOAD and the HIGH VOLTAGE FAULT indicators will illuminate.

#### 4-33. DETAILED DESCRIPTION OF CIRCUITS

#### 4-34. RF SUBSYSTEM

4-35. OSCILLATOR MODULE 1A2A1 (figure 8-1). The oscillator module consists of two switch-selectable crystal-controlled oscillator stages (transistors Q1 and Q2), a buffer squaring amplifier (transistor Q3), an integrated circuit divider (integrated circuit U1), and a power amplifier (transistor Q4).

4-36. Switch S1 on the printed-circuit board, enables either oscillator Q1/Y1 or oscillator Q2/Y2 for operation. These stages are Pierce oscillators with series resonant circuits which derive operating voltages of 15 Vdc from Zener diode regulator CR1. Crystals Y1 and Y2 operate at either two times or four times the transmitter carrier frequency. For carrier frequencies between 535 and 1250 kHz, the oscillators operate at four times the carrier frequency. For carrier frequencies between 1251 and 1605 kHz, the oscillators operate at twice the carrier frequency. Because the oscillators always operate within a stable frequency range, the need for temperature-controlled ovens is eliminated. The output of the oscillator is coupled through capacitor C6 or C12 to the next stage.

4-37. The buffer-squaring amplifier, formed by transistor Q3 and associated components, is overdriven by the oscillator stage to generate a square wave at the collector of transistor Q3. Transistor Q3 operates at 5.1 volts dc derived from Zener regulator diode CR2. Diode CR3 prevents the base of transistor Q3 from going more than 0.6 volts negative. Inductor L1 provides a high impedance to the switching frequency so that the collector of transistor Q2 forces a square wave. Diode CR4 conducts when the transistor Q2 collector voltage attempts to swing higher than the supply voltage derived from diode CR2. The collector of transistor Q3 provides a 5-volt peak-to-peak square wave to drive the following stage.

4-38. Integrated circuit U1 is a divider which operates at 5.1 volts dc derived from Zener diode regulator CR2. This circuit is configured to divide by two or four, depending upon the crystal frequency, by the arrangement of jumpers on terminals 7, 8, 9, and 10. A jumper between terminals 9 and 8

will cause integrated circuit U1 to divide by two. Jumpers between terminals 7 and 9 and between terminals 6 and 8 will cause integrated circuit U1 to divide by four. In either case, the output at pin 8 is a 2-to 4-volt peak-to-peak square wave at the transmitter carrier frequency.

4-39. Power amplifier transistor Q4 is driven by the output of divider integrated circuit U1 which drives transistor Q4 near saturation to provide maximum output. The output of transistor Q4 drives Intermediate Power Amplifier 1A2A3A1.

4-40. Two LED indicators are provided to permit rapid verification of oscillator operation. Positive portions of the rf output are rectified by diode CR5 to drive indicator LED DS2. This indicator illuminates to indicate that transistor Q4 and preceding stages are operating properly. Indicator LED DS1 is connected across the 30-volt supply and illuminates when the power supply and fuse F1 are operational. Proper operation of the circuit is assumed when both indicators are illuminated with nearly the same brilliance.

4-41. Relay K1 is energized when high voltage is off to hold the oscillator off and prevent excitation to the PA tube grid while its filament is heating. With relay K1 energized, Zener diode CR2 is shorted to ground and oscillator operation is inhibited. When high voltage is switched on, the HV contactor switches a ground to relay K1, the relay is deenergized, and the oscillator is allowed to operate.

4-42. When a dissipation overload occurs, a ground input via diode CR6 to Zener diode CR1 causes the oscillator output to go to zero volts.

4-43. IPA AND RF DRIVERS, 1A2A3. The IPA and the four rf driver modules are identical units (with the exception of two jumpers added when a module is used as the IPA stage). Transistors Q1 and Q2 are connected to operate in push-pull switching mode. Transformer T1 provides the proper impedance and phase relationships to drive the push-pull circuit. When connected as the IPA stage, a jumper is installed to bypass diode CR1, resistor R2, and capacitor C4. A second jumper is installed to bypass diode CR2, resistor R3, and capacitor C5. The IPA square-wave output is applied across tuned circuit, coil L2, capacitors C2, C2A, and C2B to provide a sine-wave input to the four parallel RF Driver modules.

4-44. The four rf drivers, combined in parallel, are capable of supplying up to 500 watts of rf drive to the power amplifier tube. The output of the four modules are paralleled through the 90-degree networks, coils L3, L4, L5, and L6, capacitors C3, C3A, and C3B. The power amplifier grid is driven through isolation transformer T1 on chassis 1A3.

4-45. Should one RF Driver module fail, the load to the remaining modules will decrease slightly, preventing other modules from failing. In most cases, the remaining drive is sufficient for full-output power and allows normal programming to continue. If adequate drive is not available, the dissipation limiter cycles the transmitter off. The transmitter can then be turned on at low output power and normal programming resumed.

4-46. Because the transmitter is capable of operation with only three RF Driver modules, emergency repairs in the event of an IPA module failure are possible. Jumpers can be installed in an operable RF Driver module (as described previously) and the module used to replace the IPA module until more permanent repairs can be made. Failure of an IPA module will normally be indicated by blown fuse F1 and illumination of LED DS1. Failure of an RF Driver module will result in an unbalanced output causing the LED indicator associated with the failed module (DS2, DS3, DS4, or DS5) to illuminate.

4-47. POWER AMPLIFIER GRID CIRCUIT (figure 8-2). Transformer T1 on Isolated Plate Chassis 1A3 isolates the RF Drivers from the floating power amplifier grid circuit and provides the necessary 180-degree phase-shift for power amplifier neutralization. The transformer is tuned by fixed capacitor 1A3C1A and variable grid tuning capacitor 1A3C1. Neutralizing is provided by capacitor 1A3C9 in series with variable neutralizing capacitor 1A3C3.

4-48. The power amplifier utilizes grid leak bias developed by resistors 1A3R1 and 1A3R2, and capacitor 1A3C4. Because the dissipation limiter protects the power amplifier from any loss of grid drive, no fixed bias is required.

4-49. The cathode and the plate of the power amplifier are both tuned to the 3rd harmonic of the carrier frequency. In the cathode circuit, inductor 1A3L1 and capacitor 1A3C2 are tuned to the 3rd harmonic. In the plate circuit, inductor 1L5, capacitor 1C13, blocking capacitor 1C12, tuning capacitor 1C14, together with the power amplifier tube capacity, form the resonant 3rd harmonic efficiency circuit. The remainder of the output network consists of conventional "L" sections to provide matching facilities for the plate circuit of the power amplifier into the desired load impedance. A 225-degree phase-shift across the output network reduces interaction of plate and loading controls during tune-up.

#### 4-50. AUDIO SUBSYSTEM

4-51. MODULATION ENHANCER (figure 8-3). When the OPERATIONAL/BYPASS switch is in the OPERATIONAL position, the audio input is applied across switch-selectable pads controlled by the CAL OUT-ENHANCING/1 dB/2 dB/3 dB switch. In the CAL OUT position, the audio signal is routed directly to the transmitter without clipping to permit adjustment of the modulation prior to enhancement. When the ENHANCING 1 dB, 2 dB, or 3 dB position is selected, the audio line is applied to diodes CR6 and CR8 at the inputs to the positive and negative-clipping circuits formed by transistors Q1 through Q4.

4-52. The clipping threshold for the positive and negative peaks of the audio input are independently adjusted by front panel control potentiometers R16 (NEG PEAK) and R20 (POS PEAK). These potentiometers are connected to the  $\pm 12$ -volt power supply formed by transformer T1, bridge rectifier CR1 through CR4, and Zener diodes CR5 and CR7. They are adjusted to set the switching levels of transistor Q1/diode CR6 and transistor Q3/diode CR8. When the audio input goes sufficiently positive to overcome this switching level, diode CR6 and transistor Q1 conduct to prevent any further positive increase. With transistor Q1 ON, transistor Q2 turns ON and LED indicator



DS2 (NEG PEAK) illuminates. Diode CR8, transistors Q3 and Q4, and LED indicator DS3 (POS PEAK) function similarly to clip negative excursions at maximum output of transistor Q4. The Modulation Enhancer is factory installed such that with normal audio inputs, the NEG PEAK control adjusts clipping of negative modulation peaks and the POS PEAK control adjusts clipping of positive modulation peaks.

4-53. POWER indicator DS1 is illuminated whenever primary power is applied and the internal +12-volt power supply is functioning properly.

4-54. PDM AND AUDIO DRIVER, 1A1 (figure 8-4). The PDM and Audio Driver contains three printed-circuit boards. The PDM signal is generated and amplified on board A1. The PDM signal is further amplified on board A3 to develop the required drive to the modulator tube. Board A2 provides the audio and dc bias for the threshold amplifier and also provides feedback circuits, a dissipation limiter, carrier shift correction, and high/low power adjust. It also includes a Bessel filter, to reduce overshoot on clipped or heavily limited audio input signals, and a modulation tracking circuit.

4-55. Principles of Pulse Duration Modulation. A simplified diagram of a PDM modulator is shown in figure 4-2. The output of a 75 kHz oscillator is clipped to form a square wave, and integrated to form a ramp, or sawtooth voltage. This voltage is summed with the audio signal at the input of a threshold amplifier. The output of this amplifier is a modulated pulse train wherein amplitude changes in the audio input signal appear as the duty cycle change of constant amplitude rectangular waves.

4-56. PDM Board 1A1A1. Transistor Q1 forms a 75 kHz LC oscillator. Crystal control is not necessary as the frequency output is not critical. Capacitor C4 functions as a blocking capacitor and couples the output signal to the base of transistor Q2. Transistor Q2 is overdriven by the sine wave and forms a 20-volt peak-to-peak square wave at capacitor C7. Feedback diodes CR1 and CR2 ensure the rise time of the square wave under this overdriven condition.

4-57. Resistor R7 and capacitor C8 integrate the square wave to form a sawtooth waveform resembling a triangle at the junction of resistor R7, capacitor C8, and resistor R9. Audio signal, audio feedback and dc feedback are added to the triangle waveform through resistors R12 and R10. DC bias voltage from the PDM power output controls applies a positive voltage, dependent on the control settings, to terminal 4. This voltage is summed with the triangle waveform through resistor R11.

4-58. Transistor Q3 is a compensated threshold amplifier which conducts when the voltage at the base reaches approximately 0.7 volts and cuts off when the base voltage drops below the turn on point. Audio added to the triangle wave varies above and below the 0.7 volt threshold point of transistor Q3. As the triangle wave goes above the threshold of transistor Q3, the voltage at the collector of transistor Q3 becomes a square wave with a duration equal to the percentage of the triangle wave above the threshold of conduction. Transistor Q3 outputs a 75 kHz pulse train, the pulse width varying linearly according to the audio input and dc bias.

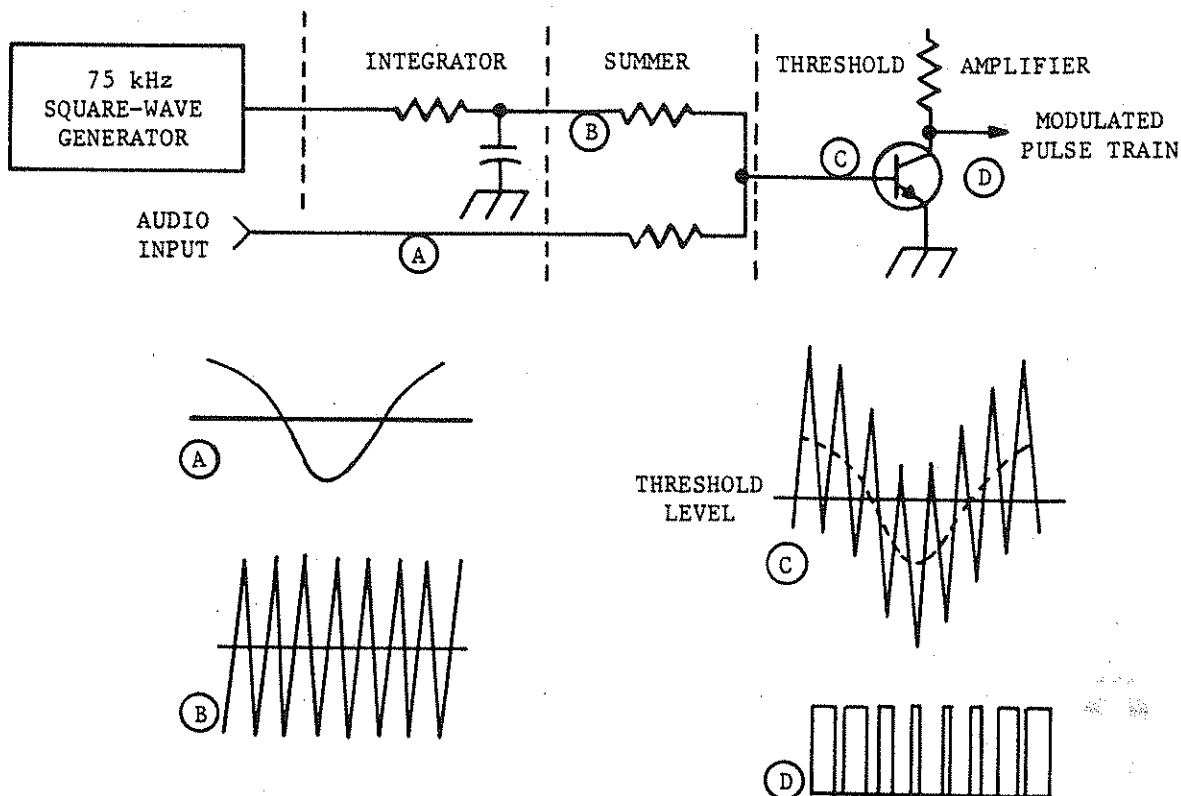

Figure 4-2. Pulse Duration Modulator, Simplified Diagram

4-59. The audio input from PDM board A2, dc feedback from the dissipation control, and a dc level proportional to the setting of the power output control are all summed with the triangular waveform at the base circuit of threshold amplifier Q3. The audio input from PDM board 1A1A2 also includes a feedback inversely proportional to the audio output of the PA stage. The audio feedback, previously shaped for a desired response, minimizes the carrier shift and improves modulation linearity and response. The dc feedback from the dissipation control is inversely proportional to the dissipation of the power amplifier. If power amplifier dissipation increases above a preset value, the threshold amplifier duty cycle changes to decrease the power output.

4-60. During operation, a bias is established which causes transistor Q3 to output a 75 kHz pulse of approximately 40 percent duty cycle. When the audio is added to the triangle wave, it causes the output from transistor Q3 to vary in pulse width around this bias setting to plate modulate the PA. The PA is capable of being controlled in excess of 125 percent modulation.

4-61. Transistor Q4 is overdriven by the collector voltage of transistor Q3 to further square the waveform and provide adequate drive to transistor Q5. Zener diode CR4 provides a stabilized voltage for transistors Q3 and Q4.

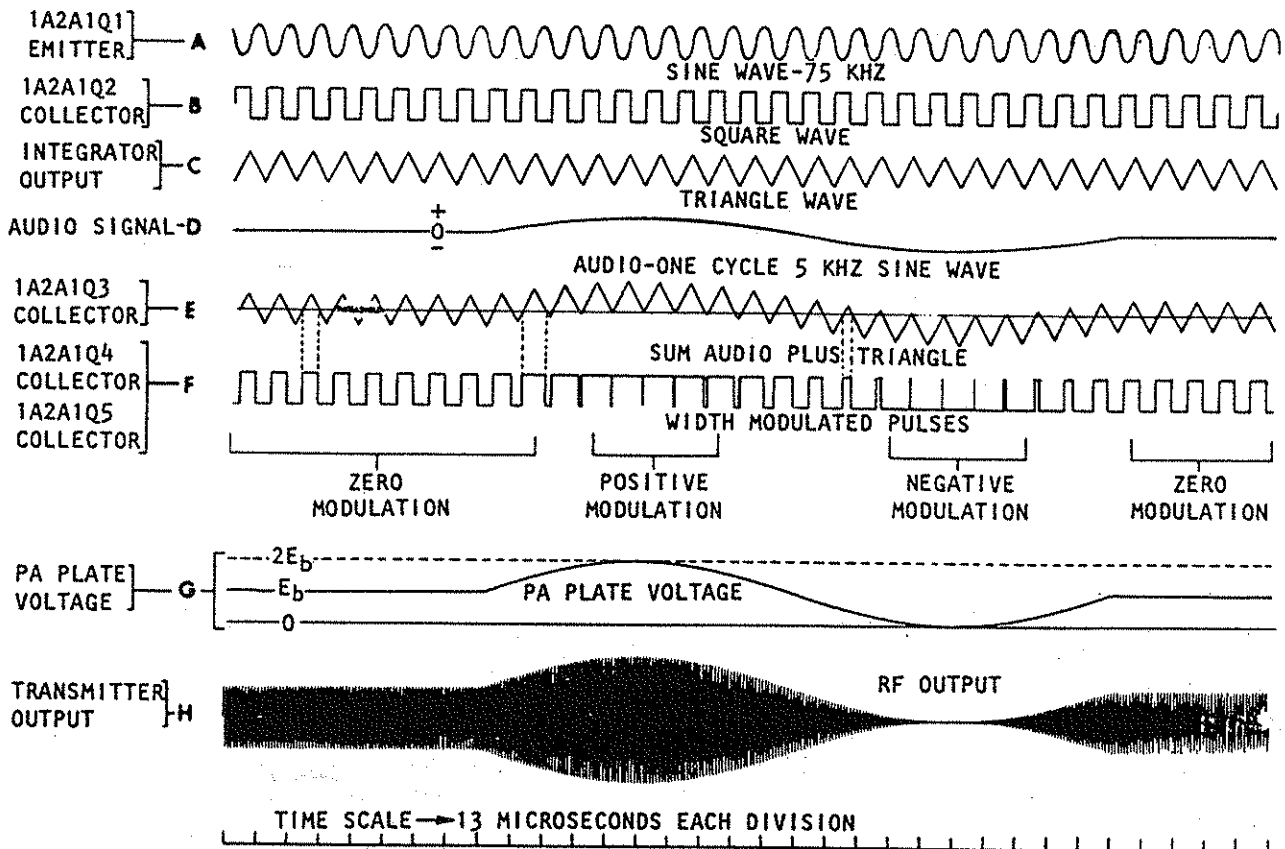

Figure 4-3. PDM Waveforms

Diodes CR5 and CR6 prevent transistor Q5 from saturating. Transistor Q5 outputs a square wave of approximately 6V peak-to-peak.

4-62. Audio Driver Board, 1A1A3. On board 1A1A3, voltage amplification is accomplished by transistor Q1. A 6-volt swing on the base of transistor Q1 produces a 250-volt swing at its collector. Because of its saturation time-delay, feedback diodes are employed to ensure the rise time of the square wave from transistor Q1. Although the collector of transistor Q1 goes from +250 volts to near zero volts, the modulator grid requires a voltage swing from zero volts to -250 volts. The required offset to furnish this voltage range is accomplished by Zener diodes CR8 through CR11. The diodes are held in the conducting mode by the modulator bias present at terminal 10.

4-63. Auxiliary driver transistor Q2 provides the current necessary to fully saturate the modulator grid on high positive peaks. Zener diode CR15 provides circuit protection by preventing the grid drive from going more positive than +47 volts should the modulator tube fail or the tube be out its socket when the transmitter is turned on. Diode CR14 disconnects the modulator grid from the audio driver if the grid rises above +47 volts (such as could happen should an arc occur between the plate and the grid within the modulator tube).

4-64. Auxiliary modulation inductor 1A1L1 is connected to terminal 2 of the Audio Driver board and provides additional modulation drive to the grid of the modulator tube. The additional grid drive is required for high-current pulses (positive peaks) which require more drive than low-current pulses (negative peaks). The output of the Audio Driver is routed via terminal 10 directly to the grid of the modulator tube.

4-65. MODULATOR TUBE CIRCUIT (figure 8-2). The modulator tube circuit consists of a modulator tube, 75 kHz filter, and a damper diode assembly.

4-66. Modulator Tube. The modulator is a 4CX3000A tube which amplifies the Audio Driver output to modulate the power amplifier tube. Refer to the tube data sheets in Appendix A for detailed information on the modulator tube.

4-67. 75 kHz Filter. The 75 kHz Filter is formed by inductors 1L1, 1L2, and 1L3 and capacitors 1C5, 1C8, and 1C10 in the plate circuit of the modulator tube. The filter removes the 75 kHz pulses generated by the PDM oscillator, leaving the audio to modulate the power amplifier.

4-68. Damper Diode Assembly. The damper diode assembly is formed by diodes CR1 through CR13. This assembly provides protection to the modulator tube by conducting into the power supply when the plate voltage rises above the supply voltage. When power is suddenly removed from the modulator tube, current from the 75 kHz Filter would try to flow back through the tube and cause arcing. However, the damper diode assembly goes into conduction because of the rise in plate voltage and thereby prevents damage to the tube.

#### 4-69. AUDIO INPUT, DISSIPATION OVERLOAD, AND FEEDBACK 1A1A2

4-70. Resistors R1 through R6 form an input isolation pad and properly terminate an input RFI filter consisting of coils L1 and L2, and capacitors C1 through C4. Resistors R9 and R10 together with diode CR1 provide input overvoltage protection for differential amplifier integrated circuit U1. Differential amplifier integrated circuit U1 provides the differential to single-ended conversion and prevents unwanted common-mode signals from modulating the transmitter. Low-pass Bessel filter integrated circuit U2 may be inserted by switch S1 to reduce complex wave overshoot and to eliminate aliasing. Audio is applied to modulation tracking integrated circuit U3 where it is multiplied by the dc voltage output of the low-pass filter. This filter consists of resistors R55, R56 and R57 and capacitors C37, C38 and C39. The output represents transmitter carrier level. The resultant level-controlled audio is applied to PDM board 1A1A1.

4-71. BESSEL FILTER. A phase-linear bessel low-pass filter is used in the circuitry after the transformerless input amplifier. This filter eliminates high-frequency short duty-cycle transients which could cause the PDM filter to overshoot which would cause overmodulation "hits". These high-frequency transients are typically produced by audio processing equipment that employ pre-emphasis and clipping. The bessel low-pass filter also causes high-frequency rolloff. The amount of overshoot reduction and the amount of high-frequency rolloff are directly related. Overshoot can be completely eliminated but at the expense of high-frequency response. The bessel turnover frequency is controlled by single resistor network R19. This resistor network is socket installed and easily replaceable with other standard resistor networks. Refer to Maintenance Section V for useable networks.

4-72. DISSIPATION LIMITER. Transistors Q1 and Q2 form a part of a Schmitt trigger with transistor Q1, biased by resistor R24, normally conducting. A sampling of the input power and a positive voltage from Feedback Detector 1A8, output power, is summed together. In the event that the input power increases without increasing the output power, the voltage at the junction of resistors R22 and R23 goes negative. This negative voltage cuts off transistor Q1 which, in turn, causes transistor Q2 to conduct. With Q2 conducting, the voltage at terminal 1A1A2-0 goes to ground. The ground is applied to Zener diode CR1 through diode CR6, removing the supply voltage from the oscillator and removing rf drive. The ground is also felt at the input on threshold amplifier transistor Q3 which stops all pulses and cuts off the modulator. With the modulator cut off, the power amplifier plate voltage is cut off, and the rf output drops to zero. At this time the Schmitt trigger returns to its original condition (transistor Q1 conducting).

4-73. NEGATIVE FEEDBACK. Feedback Detector 1A6 provides negative feedback voltage through terminal 1A1A2-N which is proportional to the carrier and the detected audio output. Biasing resistor 1A1A2R49 supplies voltage back to detection diodes 1A6CR1 and 1A6CR2 in the Feedback Detector. Inductor 1A1A2L4 filters out any stray rf that may be picked up. Remote Power Adjust potentiometer 1A1R2 allows for a slight adjustment of the dc feedback for fine-power control. Both ac and dc feedback are routed through resistor R62

and summed with the audio input. The dc feedback is applied to a carrier-level low-pass filter, which consists of resistors R55, R56, and R57 and capacitors C37, C38, and C39. The output of the filter is a dc voltage proportional to the carrier level. This voltage is multiplied by the audio input signal in integrated circuit U3 which results in a constant modulation percentage vs power output level.

4-74. Variable Feedback. Resistor R64 and capacitors C43 and C44 shape the feedback frequency for resistors R62 and R63, and capacitors C41 and C42 such that there is approximately 20 dB of dc feedback (12 dB at 20 Hz, 6 dB at 1 kHz, and near 0 dB at 5 kHz and above). Shaping is required to assure proper operation when operating into very high Q loads (directional antenna arrays) and attenuation of 60 Hz hum.

4-75. Positive Feedback. Positive feedback from the Feedback Detector through terminal 1A1A2-M provides carrier amplitude shift correction and excitation for the dissipation limiter.

4-76. FLAG AND OVERLOAD 1A2A2. This module assures proper handling of a fault condition and counts overloads. When more than three or four overloads occur in rapid succession, the high voltage is removed. Latching relays K1 through K5 remember the overloads and illuminate the appropriate fault indicator on the meter panel. Remembering overloads, even after the transmitter has been shut down or gone through a power failure, is an aid in isolating problems in the transmitter or antenna system. Depressing the RESET pushbutton switch resets the latching relays.

#### NOTE

Some overloads cause the high-voltage capacitors to discharge with a loud, audible sound.

4-77. Arc Overloads. Refer to figures 8-1 and 8-2. Power line transients, failure of components in the 75 kHz filter, or failure of the damper diode can cause an arc-over of ball gaps 1E3, 1E4, or 1E5. If any of these gaps arc-over, current will flow through resistors 1R8 and 1R9. The voltage that is developed at the junction of resistors 1R8 and 1R9 is fed to relay 1A2A2K1 (through terminal 13). Current limiter resistor 1A2A2R37 limits the current to Zener diode 1A2A2CR21 which limits the voltage across relay 1A2A2K1 to approximately 6.8 volts. Closing of relay contacts illuminates the ARC indicator on the front panel. Each time a ball gap arcs over, a dc overload will also occur. This causes the transmitter to recycle and illuminate the dc fault indicator.

4-78. VSWR Overload. Directional Coupler 1A8 develops a positive voltage output which is fed to the threshold amplifier integrated circuit 1A2A2U1B. VSWR TRIP SENSITIVITY ADJUST potentiometer 1A2A2R32 is set to provide a predetermined voltage level to the input of integrated circuit 1A2A2U1-6. As the VSWR voltage increases beyond the input level, the output voltage at integrated circuit 1A2A2U1-5 increases, causing transistor 1A2A2Q2 to conduct and drive the collector to ground, which in turn energizes relays 1A2A2K2 and

1A2A2K7 and places a ground at the input of the threshold amplifier transistor 1A1A1Q3 through diodes 1A2A2CR11 and CR15. When transistor 1A1A1Q3 cuts off, the 75 kHz pulses stop, the modulator is cut off, the PA is cut off, and the rf output is zero. Because there is no rf output, the VSWR drops to zero, transistor 1A1A1Q3 conducts, the modulator goes into operation, and the rf output is restored.

4-79. DC Overload. DC Overload Relay 1A4A1K1 energizes when an excessive amount of current flows through resistor R17 (figure 8-2). One set of dc relay contacts places a ground at terminal board 1A2A2TB1-8 which causes relay 1A2A2K3 to energize and illuminate the dc fault indicator on the front panel. The ground also causes relay 1A2A2K7 to energize through diode CR12 and cuts off threshold amplifier 1A1A1Q3 through diode CR15. The same transmitter cut-off sequence occurs as described in the preceding paragraph.

4-80. Dissipation Limiter. When the dissipation limiter is at ground, relay 1A2A2K4 energizes and illuminates the DISS indicator on the front panel. Relay 1A2A2K7 is closed momentarily through diode 1A2A2CR13. The ground also disables threshold amplifier transistor 1A1A1Q3, and transmitter recycling occurs as described previously.

4-81. Modulator Screen Overload. Modulator Screen Overload Relay 1A4A1K2 connects a ground to terminal board 1A2A2TB1-4 which causes relay 1A2A2K5 to close. This action causes the MOD indicator on the front panel to illuminate, provides a ground for relay 1A2A2K7 to operate through diode CR14, and disables threshold amplifier transistor 1A1A1Q3. The transmitter then recycles as described previously.

4-82. Overload Counter. Plus 30 volts is placed on resistor R5 in series with the coil of relay K7. Whenever an overload occurs, a ground is applied to energize relay K7. Switch S1, in the open position, allows the transmitter to recycle. In the closed position, switch S1 causes the transmitter to turn off at the first overload. When relay K7 energizes, capacitor C1 immediately charges to 30 volts through resistor R7 or through switch S1. When relay K7 is energized because of an overload, the charge on capacitor C1 is dumped on capacitor C2. With switch S1 in the open or recycle position, the voltage at capacitor C2 will charge to a certain voltage (dependent upon the length of time relay K7 is energized) after the first dump. If the overload is cleared, relay K7 deenergizes, opening its contacts to allow capacitor C1 to again charge to plus 30 volts. Should another overload occur quickly, the 30-volt charge on capacitor C1 will again be dumped on capacitor C2 causing its voltage to rise to a higher value. On the third or fourth overload, capacitor C2 charges to approximately 15 volts (firing voltage for Zener diode CR16), diode CR16 conducts, and causes transistor Q1 to conduct. When transistor Q1 turns ON, its collector goes to near ground, energizing the off coil of main latching relay 1A4A1K3, which turns off the transmitter. Should switch S1 be in a closed position, the first overload will place 30 volts on capacitor C2 causing transistor Q1 to conduct, which turns off the transmitter.

4-83. Capacitor C2 discharges through resistor R8 with a 35-second time constant. If overloads occur at approximately 15 seconds (or greater)

intervals, the transmitter will recycle from overloads continuously without being reset manually. Switch S1 should be closed during maintenance or troubleshooting so that if an overload does occur, the high voltage will be removed immediately.

4-84. Remote PA Plate Voltage Metering Amplifier. The operational amplifier (top half of integrated circuit U1 figure 8-1) provides isolation of the transmitter metering from the remote metering. A short circuit in the remote metering will not affect the transmitter metering circuit.

4-85. AC CONTROL 1A4. Refer to figure 8-6. Filament voltage is applied to the transmitter by depressing the FILAMENT ON pushbutton switch located on the front panel or at the remote control. With switch S1 in LOCAL, relay K1 (filament start) is energized and will self-latch through a set of holding contacts. With the LOCAL/REMOTE switch in REMOTE, relay K1 is energized and remains energized by a holding voltage supplied by the remote control. In order to meet FCC fail-safe specifications, relay K1 does not self-latch in REMOTE operation.

4-86. After relay K1 closes, power is applied to blower 1B1. When the air pressure inside the cabinet reaches a preset level, pressure switch 1S1 closes and relay K6 is energized. With relay K6 energized, filament voltage is applied, low-voltage power supplies are activated, and the PA METER indicator illuminates.

4-87. Approximately five seconds after 30/60-volt power supply is activated, time-delay relay 1A4A1TD1 closes. If front panel or remote HV ON pushbutton switch has been depressed, relay K2 will be latched in the HV ON position. Through the closure provided by time-delay relay 1A4A1TD1, relay K3 and subsequently relay K4 will close, activating the high-voltage supply. In the event of a power failure, time-delay relay 1A4A1TD1 will open immediately, and relay K2 will remain closed because it is mechanically latched.

4-88. When relay K2 is latched in the HV ON position, 115 Vac is applied to step-start relay K3. When relay K3 is closed, three-phase power is applied to high-voltage transformer T4 through resistors R6, R7, and R8. At this time, relay K4 closes bypassing resistors R6, R7 and R8, which allows 240 Vac to be applied to transformer T4. A set of relay K4 contacts deenergizes relay 1A2A2K6 and relay 1A2A1K1 to allow the PDM and the rf oscillator to operate. This circuitry prevents rf power from being generated during the step-start sequence.

4-89. If a short circuit occurs during the step-start sequence, resistors R6, R7, and R8 act as current limiters. A sample voltage from resistor R8 will activate relay 1A4A1K4 when an overload condition exists in the high-voltage supply. The high voltage is removed and the DC Overload indicator illuminates on the front panel. The time between depressing the HV ON pushbutton switch and activation of relay 1A4A1K4 is only a few milliseconds. If the cause of the overload is not remedied, relay 1A4A1K4 will activate each time the HV ON pushbutton switch is depressed.



4-90. High/Low Power Control. The high-power or low-power selection is accomplished by latching relay K5 and can be made from the front panel or from remote control. Latching relay K5 operates the HIGH/LOW indicator lights, changes the modulator screen voltage, and energizes relays 1A11K1 and 1A1A2K1 when in the low-power position. Relay 1A11K1 switches resistor 1A11R3 in or out of the circuit to balance the modulation sample between high and low power. Relay 1A1A2K1 changes the attenuation of the audio input pad.

4-91. DIRECTIONAL COUPLER BOARD 1A8 (figure 8-2). The directional coupler board provides three functions in the transmitter, forward power indication, reflective power indication, and relative VSWR indication.

4-92. The rf output current of the transmitter passes through current transformer T1, establishing a voltage at resistors R4 and R5 which is proportional to the current flowing in the rf transmission line. A voltage sample is obtained across capacitor C4 from capacitor C5. Another voltage sample across capacitor C8 is obtained from capacitor C10. The voltage developed across resistor R4 is 180 degrees out-of-phase from the voltage developed across resistor R5. When properly terminated and adjusted, the voltage across resistor R5 equals the voltage across capacitor C8 and is in phase, causing 0 voltage across diode CR2 and 0 voltage at terminal E2 of the Directional Coupler board 1A8, and a 0 indication on the reflected power meter. The voltage at capacitor C4 and the voltage at resistor R4 will be equal but 180 degrees out-of-phase causing a voltage across diode CR1 and a voltage to the forward power meter through terminal E3. As VSWR changes, the in-phase condition of resistor R5 and capacitor C8 will cease, causing a voltage to exist on the reflected power meter through terminal E2. As the voltage on capacitor C4 and resistor R4 begins to change in phase, the voltage on the power meter terminal E3 begins to decrease. A positive voltage sample is also developed at resistor R1 which is routed through terminal E4 to the threshold amplifier on overload board 1A2A2.

4-93. HIGH-VOLTAGE TRANSFORMER PROTECTION. The problem being protected against is one of intense localized heating of the high-voltage transformer. There are three (3) conditions in which the high-voltage transformer will experience this problem.

- a. Open rectifier.
- b. Open high-voltage secondary winding.
- c. Shorted secondary turns in the transformer.

4-94. Any imbalances in the operation of the multiphase high-voltage power supply will result in the generation of 100/120 Hz noise. Normally, the principle noise frequency at the sampling point is 300/360 Hz. Thus, by sensing an increase in the 100/120 Hz noise component, the transformer can be protected against all situations which could result in its destruction by becoming overheated.

4-95. The protection circuitry consists of an active filter designed to amplify 90-130 Hz. The filtered signal is peak-detected and compared against a reference. If the 100/120 Hz noise level is excessive for greater than one period of 100 Hz, the transmitter will be shut down by the DC Overload circuitry and the LED on the HV Protection Board will illuminate indicating the cause of the shutdown. The LED can be extinguished by depressing the RESET pushbutton for FAULT INDICATORS located on the meter panel.

888-2109-010

4-17/4-18

**WARNING:** Disconnect primary power prior to servicing.

## SECTION V

### MAINTENANCE

#### 5-1. INTRODUCTION

5-2. This section provides system performance checks, preventive maintenance information, and corrective maintenance procedures for the HARRIS MW-5B BROADCAST TRANSMITTER.

#### 5-3. PURPOSE

5-4. The information contained in this section is intended to provide guidance for establishing a comprehensive maintenance program to promote operational readiness and eliminate downtime. Particular emphasis is placed on preventive maintenance and record-keeping functions.

#### 5-5. STATION RECORDS

5-6. The importance of keeping station performance records cannot be over-emphasized. Separate logbooks should be maintained by operation and maintenance activities. These records can provide data for predicting potential problem areas and analyzing equipment malfunctions.

#### 5-7. TRANSMITTER LOGBOOK

5-8. As a minimum performance characteristic, the transmitter should be monitored, using front panel meters, and the results recorded in the Transmitter Logbook at each shift change, at least once per day, or as required by the appropriate regulatory agency.

#### 5-9. MAINTENANCE LOGBOOK

5-10. The maintenance logbook should contain a complete description of all maintenance activities required to keep the transmitter in operational status. A listing of maintenance information to be recorded and analyzed to provide a data base for a failure reporting system is as follows:

SYSTEM ELAPSED TIME	Total time on transmitter.
NAME OF REPAIRMAN	Person who actually made the repair.
STATION ENGINEER	Indicates Chief Engineer noted and approved the repair to the transmitter.
DISCREPANCY	Describe the nature of the malfunction including all observable symptoms and performance characteristics.
CORRECTIVE ACTION	Describe the repair procedure used to correct the malfunction.

DEFECTIVE PART(S)

List all parts and components replaced or repaired and include the following details:

- a. TIME IN USE
- b. PART NUMBER
- c. SCHEMATIC NUMBER
- d. ASSEMBLY NUMBER
- e. REFERENCE DESIGNATOR

5-11. SAFETY PRECAUTIONS

**WARNING**

DISABLE PRIMARY POWER TO THE TRANSMITTER AND USE THE GROUNDING HOOK TO DISCHARGE ANY RESIDUAL POTENTIAL FROM ALL COMPONENTS BEFORE TOUCHING THEM.

5-12. Because of high voltages and currents, it is very dangerous and it is not a recommended procedure to make measurements or replace components with the power on. The design of the transmitter provides safety features such that when a panel is open or a grounding stick is not in its proper place, the interlock switch opens and removes power from the transmitter. DO NOT SHORT OUT OR BYPASS THESE SWITCHES. Always use a nonconductive type tool when replacing or adjusting components.

5-13. Grounding sticks are provided as a safety feature. They consist of a metal rod with a phenolic-plastic handle. The metal end is connected to the transmitter ground. Before touching any component in the transmitter, use the grounding stick and touch every component in the area or circuit on which maintenance is to be performed.

5-14. PREVENTIVE MAINTENANCE

5-15. Preventive maintenance is a systematic series of operations performed periodically on equipment. Since these procedures cannot be applied indiscriminately, specific instructions are necessary. Preventive maintenance consists of seven operations: inspecting, feeling, tightening, cleaning, adjusting, lubrication, and painting.

- a. Inspect. Inspection is the most important preventive maintenance operation because it determines the necessity for the others. Become thoroughly acquainted with normal operating conditions in order to recognize and identify abnormal conditions readily. Inspect for:
  1. Overheating, which is indicated by discoloration, bulging of parts, and peculiar odors.
  2. Leakage of grease and oil.

3. Oxidation.
  4. Dirt, corrosion, rust, mildew, and fungus growth.
- b. Feel. Use this operation to check parts for overheating, especially rotating parts, such as blower motors. By this means, the need for lubrication, the lack of proper ventilation, or the existence of some defect can be detected and corrected before serious trouble occurs. Become familiar with operating temperatures in order to recognize deviations from the normal range.
  - c. Tighten. Tighten loose screws, bolts, and nuts. Do not tighten indiscriminately as fittings that are tightened beyond the torque for which they are designed may be damaged or broken.
  - d. Clean. Clean parts only when inspection shows that cleaning is required. Use approved cleaning solvent. Pick up dust using a vacuum cleaner. Do not use a blower or compressed air except when specified.
  - e. Adjust. Make adjustments only when inspection shows that they are necessary to maintain normal operation.
  - f. Lubricate. Lubricate meshing mechanical surfaces at specified intervals, and with specified lubricants, to prevent mechanical wear and keep the equipment operating normally.
  - g. Paint. Paint steel surfaces with the original type of paint using a prime coat if necessary when inspection shows rust, or worn or broken paint film.

#### 5-16. BLOWER FILTER CLEANING

5-17. A blower assembly is provided in the transmitter. The blower filter is a replaceable, washable, cartridge type. Inspect the filter at least once a week with replacement done on an as-needed or every-month basis, whichever occurs first. Dirt in the filter may not be noticed during visual inspection unless the filter is gently tapped against a white paper to observe the quantity of accumulated dirt. If the weekly inspection indicates excessive dirt accumulation in the filter or if the monthly periodic service period has expired, wash or replace the filter.

#### 5-18. BLOWER CLEANING

5-19. Inspect pressure blower for dust accumulation on blower wheels and propellers monthly. Remove dust with a vacuum cleaner.

#### 5-20. MAINTENANCE OF COMPONENTS

5-21. The following paragraphs provide information necessary for the maintenance of components.

5-22. TRANSISTORS. Preventive maintenance of transistors is accomplished by performing the following steps:

- a. Inspect the transistors and surrounding area for dirt as accumulations of dirt or dust could form leakage paths.
- b. Remove dust from the area.

**WARNING**

DO NOT TOUCH HEAT SINK AND TRANSISTORS MOUNTED IN HEAT SINKS IMMEDIATELY AFTER REMOVING POWER. BURNS MAY RESULT FROM CONTACT.

- c. Examine all transistors for loose connections or corrosion.

5-23. CAPACITORS. Preventive maintenance of capacitors is accomplished by performing the following steps:

- a. Examine all capacitor terminals for loose connections or corrosion.
- b. Ensure that component mountings are tight.
- c. Examine the body of each capacitor for swelling, discoloration, or other evidence of breakdown.
- d. Inspect oil-filled or electrolytic capacitors for leakage signs.
- e. Use standard practices to repair poor solder connections with a low-wattage soldering iron.
- f. Clean cases and bodies of all capacitors.

5-24. FIXED RESISTORS. Preventive maintenance of fixed resistors is accomplished by performing the following steps:

- a. When inspecting a chassis, printed-circuit board, or discrete component assembly, examine resistors for dirt or signs of overheating. Discolored, cracked, or chipped components indicate a possible overload.
- b. When replacing a resistor, ensure that the replacement value corresponds to the component designated by the schematic diagram.
- c. Clean dirty resistors with a small brush.

5-25. VARIABLE RESISTORS. Preventive maintenance of variable resistors is accomplished by performing the following steps:

- a. Inspect the variable resistors and tighten all loose mountings, connections, and control knob set screws. Do not disturb knob alignment.
- b. If necessary, clean component with a dry brush or a lint-free cloth.
- c. When dirt is difficult to remove, clean component with a cloth moistened with an approved cleaning solvent.

5-26. TRANSFORMERS. Preventive maintenance of transformers is accomplished by performing the following steps. The transformers are enclosed in metal housings and impregnated with an insulating compound.

- a. Examine a transformer by feeling, soon after power removal, for signs of overheating.
- b. Inspect each transformer for dirt, loose mounting brackets and rivets, loose terminal connections, and insecure connecting lugs. Dust, dirt, or moisture between terminals or a transformer may cause flashovers. Insulating compound or oil around the base of a transformer indicates overheating or leakage.
- c. Tighten loose mounting lugs, terminals, or rivets.
- d. Clean with a dry lint-free cloth or one moistened with an approved cleaning solvent.
- e. Clean corroded contacts or connections with crocus cloth.
- f. Replace defective transformers.

5-27. FUSES. Preventive maintenance of fuses is accomplished by performing the following steps:

- a. When a fuse opens, ascertain the cause before installing a replacement.
- b. Inspect fuse caps and mounts for charring and corrosion.
- c. Examine fuse clips for dirt, improper tension and loose connections.
- d. If necessary, tighten fuse clips and connections to the clips. The tension of the fuse clips may be increased by pressing the clip sides closer together.
- e. Clean fuses and clips with a small brush.

- f. Remove corrosion with crocus cloth.

5-28. METERS. Preventive maintenance of monitoring meters is accomplished by performing the following steps:

- a. Inspect meters for loose, dirty, or corroded mountings and connections.
- b. Examine leads for frayed insulation and broken strands.
- c. Check for cracked or broken plastic cases and cover glasses.
- d. Tighten loose mountings or connections. Since meter cases are made of plastic, exercise care to prevent breakage.
- e. Clean meter cases and glass cover with a dry lint-free cloth.
- f. Remove dirt from mountings and connections with a stiff brush moistened with an approved cleaning solvent.
- g. Remove corrosion with crocus cloth.

5-29. RELAYS. Replace hermetically sealed relays if they are defective. Nonhermetically sealed relays are considered normal if the following conditions exist:

- a. The relay is mounted securely.
- b. Connecting leads are not frayed, and the insulation is not damaged.
- c. Terminal connections are tight and clean.
- d. Moving parts travel freely.
- e. Spring tension is correct.
- f. Contacts are clean, adjusted properly, and make good contact.
- g. The coil shows no signs of overheating.
- h. The assembly parts are clean and no corrosion is present.

5-30. SWITCHES. Preventive maintenance of switches is accomplished by performing the following steps:

- a. Inspect switch for defective mechanical action or looseness of mountings and connections.
- b. Examine cases for chips or cracks. Do not disassemble switches.



- c. Inspect accessible contact switches for dirt, corrosion, or looseness of mountings and connections.
- d. Check contacts for pitting, corrosion, or wear.
- e. Operate the switches to determine if they move freely and are positive in action. In gang and wafer switches, the movable blade should make good contact with the stationary member.
- f. Tighten all loose connections and mountings.
- g. Adjust contact tension.
- h. Clean any dirty or corroded terminal connection or switch section with crocus cloth.
- i. Replace defective switches.

5-31. INDICATORS AND INDICATOR SWITCHES. Preventive maintenance of indicator lamps and indicator switches is accomplished by performing the following steps:

- a. Examine indicator sockets for corrosion, loose nuts, and condition of rubber grommets.
- b. Remove indicator switch by pulling the plastic cover (indicator assembly) from the case and rotating the assembly 90 degrees.
- c. Inspect indicator assemblies for broken or cracked covers, loose envelopes, loose mounting screws, and loose or dirty connections.
- d. Tighten loose mounting screws; solder loose connections. If connections are dirty or corroded, clean with crocus cloth before soldering.
- e. Clean indicator covers, bases, and glass bulb with a dry lintfree cloth.
- f. Clean corroded socket contacts and connections with crocus cloth. Low-operating voltages require clean contacts and connections.

5-32. PRINTED-CIRCUIT BOARDS. Preventive maintenance of printed-circuit boards is accomplished by performing the following steps:

- a. Inspect the printed-circuit boards for cracks or breaks.
- b. Inspect the wiring for open circuits or raised foil.
- c. Check components for breakage or discoloration due to overheating.
- d. Clean off dust and dirt with a clean, dry lint-free cloth.

- e. Use standard practices to repair poor solder connections with a low-wattage soldering iron.

### 5-33. CORRECTIVE MAINTENANCE

5-34. Corrective maintenance for the transmitter is limited by the objective of minimum down time. The transmitter was designed and built with highly reliable and proven components having excellent performance characteristics. Therefore the maintenance of the transmitter should be a relatively easy task for operating and maintenance personnel. If the need to remove and replace a defective component arises, refer to Section II, Installation. Reverse the sequence of installation to remove the component and reinstall as described.

### 5-35. ALIGNMENT AND CALIBRATION

#### 5-36. TRANSMITTER ALIGNMENT

5-37. Transmitter alignment (retuning) is not normally required and should not be performed after the original installation and checkout unless some component in the tuned circuit has been replaced due to component failure or has been replaced in order to accomplish an operating frequency change.

**WARNING**

DISABLE PRIMARY POWER TO THE TRANSMITTER. USE GROUNDING HOOK TO DISCHARGE ANY RESIDUAL POTENTIAL FROM ALL EXPOSED COMPONENTS BEFORE TOUCHING THEM.

#### NOTE

If transmitter frequency change is required refer to figure 8-5 for the required frequency determining components.

5-38. Refer to Section II, Installation for details concerning tune-up procedures during regular maintenance.

5-39. The following specialized test equipment may be needed to tune the transmitter to a different frequency:

- a. Wayne Kerr B601 RF Bridge or equivalent.
- b. A stable shielded rf signal source capable of producing 2 to 3 volts RMS at the new operating frequency, and equipped with a coaxial receptacle output.
- c. A shielded communication type receiver, equipped with an input receptacle of the coaxial-jack type, such as a BNC fitting, for a

bridge detector or a Field Strength meter with an external input jack, such as Potomac Instruments FIM-41.

- d. Several lengths of coaxial cable for interconnecting the rf bridge, the signal generator, and the detector.
- e. A high-frequency oscilloscope, fitted with a low-capacitance probe.

5-40. A Hewlett Packard 4815A RF Vector Impedance meter may be used instead of the Wayne Kerr B601 RF Bridge and the associated equipment in b., c., and d. of paragraph 5-39.

5-41. A resistor may be substituted for the antenna load at the output terminal of the transmitter if there are no strong rf fields from other nearby transmitters.

5-42. The following procedure should be followed after a component in the tuned circuit has been replaced or a frequency change is to be accomplished.

5-43. When a frequency change is to be accomplished, it will be necessary to ensure that the station antenna and the antenna coupling system will be compatible with the new frequency. A measurement of the impedance of the antenna system must be made at the point where power is to be determined.

5-44. A series of measurements should be made, starting at 20 kHz below the carrier frequency to be used, and measurements at each 5 kHz through 20 kHz above the carrier frequency to be used. These measurements must be accurate. Plot these resistance and reactance values vs the frequencies at which they were taken. Plot a curve through each set to determine the averages.

5-45. After the antenna coupling equipment has been adjusted, connect the measuring equipment to the point where the transmitter inputs to the antenna coupling equipment. Take a reading at this point. Fine adjust the coupling equipment so that the impedance at this point is nonreactive and is as near to 50 ohms as possible.

5-46. Remove the frequency determined components for the old frequency and install the new frequency determined components for the new frequency. Refer to figure 8-5.

5-47. After the frequency determined parts are installed, the harmonic traps must be reset.

5-48. Complete the following steps in the order listed to set the 2ND HARMONIC TRAP 1L12.

- a. Adjust 2ND HARMONIC TRAP control fully clockwise. Refer to figure 3-4.
- b. Disconnect the tubing from the top front end (panel end) of 1L12, 2ND HARMONIC TRAP.

- c. Connect the signal generator, tuned to twice the operating frequency, and the oscilloscope as shown in figure 5-1.

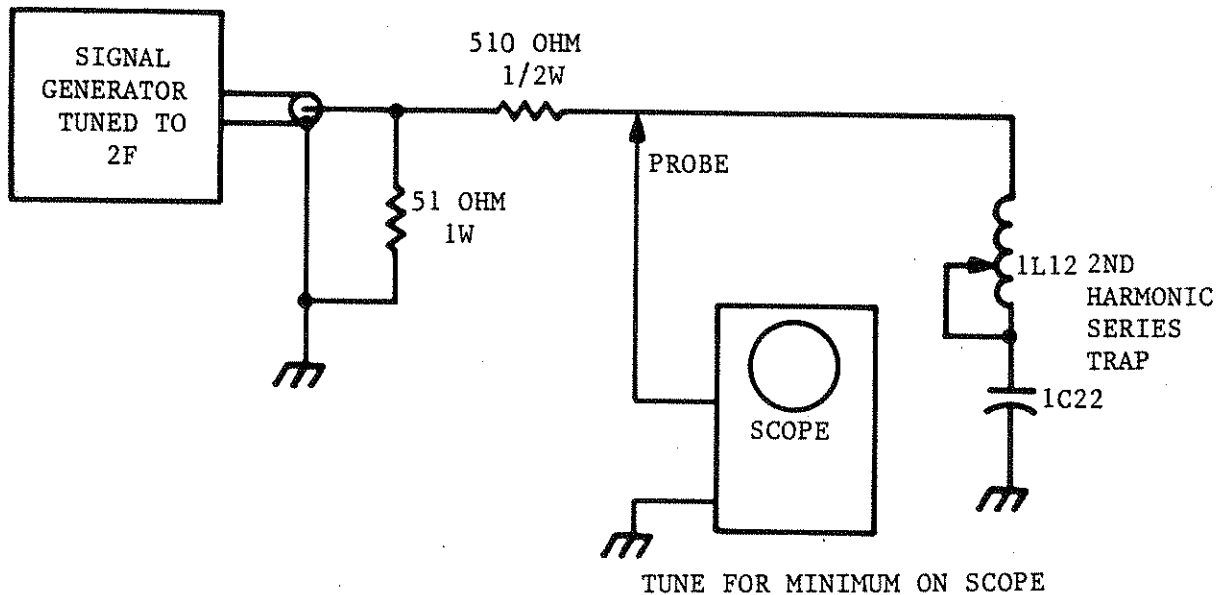

Figure 5-1. Set-Up for 1L12 Test

- d. Move the adjustable tap and adjust the tuning vane for a minimum deflection on the oscilloscope. Sweeping the signal generator may aid in tuning.
- e. Disconnect signal generator and the oscilloscope.
- f. Reconnect the tubing disconnected in step b.
- 5-49. Complete the following steps in the order listed to set the 3RD HARMONIC TRAP 1L9.
- a. Adjust 3RD HARMONIC TRAP control fully clockwise. Refer to figure 3-4.
- b. Disconnect the tubing from the top front end (panel end) of 1L9 3RD HARMONIC TRAP.
- c. Connect the signal generator, tuned to three times the operating frequency, and the oscilloscope as shown in figure 5-2.
- d. Adjust the moveable tap on coil 1L9 and adjust the tuning vane for a minimum deflection on the oscilloscope. Sweeping the signal generator may aid in tuning.
- e. Disconnect the signal generator and the oscilloscope.

f. Reconnect the tubing disconnected in step b.

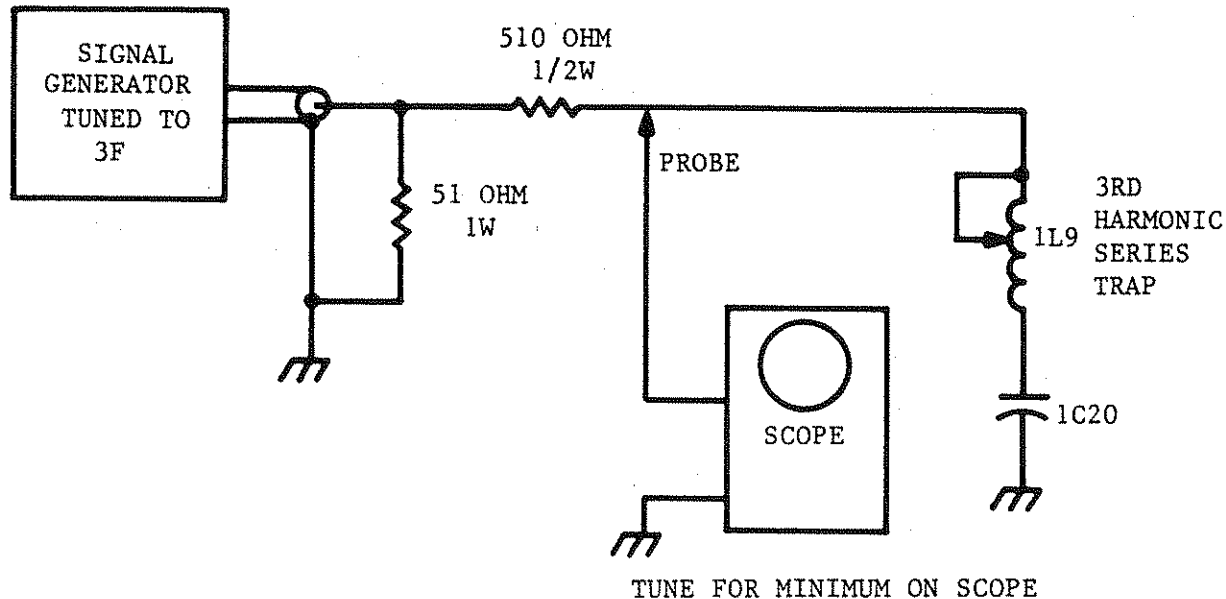

Figure 5-2. Set-Up for 1L9 Test

5-50. PA TUNE CAPACITOR 1C14

5-51. Adjust PA TUNE capacitor 1C14 according to Table 5-1.

5-52. 3RD HARMONIC RESONATOR TUNING

**WARNING**

USE GROUNDING HOOK TO SHORT ANODE OF PA TUBE TO GROUND TO ENSURE THAT NO HIGH VOLTAGE IS PRESENT. USE GROUNDING HOOK TO SHORT THE CENTER TAP OF PA FILAMENT TRANSFORMER 1T3 TO GROUND TO ENSURE THAT NO HIGH VOLTAGE IS PRESENT.

5-53. Connect the impedance measuring equipment between the anode of the PA tube and ground. Refer to figure 5-3. Tune the signal generator to three times the carrier frequency (3F). With at least one-half the turns of coil 1L8 active, adjust plate resonator coil 1L5 for antiresonance (parallel resonance) at the 3rd harmonic at the plate of the PA tube.

5-54. SETTING OUTPUT NETWORK

5-55. Retune the signal generator to the carrier frequency. Install a non-reactive load, 51-ohm 1/2-watt resistor, at the output of the transmitter.

Table 5-1. PA TUNE Capacitor 1C14 Values

F	C pF	DIAL	F	C pF	DIAL	F	C pF	DIAL
.54	344	08.2	.91	385	06.2	1.28	188	15.9
.55	323	09.3	.92	377	06.6	1.29	184	16.1
.56	302	10.3	.93	370	06.9	1.30	180	16.3
.57	283	11.2	.94	362	07.3	1.31	176	16.5
.58	264	12.2	.95	355	07.7	1.32	173	16.7
.59	245	13.1	.96	348	08.0	1.33	169	16.9
.60	231	13.8	.97	342	08.3	1.34	165	17.1
.61	214	14.7	.98	335	08.7	1.35	162	17.2
.62	197	15.5	.99	328	09.0	1.36	408	05.0
.63	431	03.9	1.00	322	09.3	1.37	405	05.2
.64	416	04.6	1.01	323	09.3	1.38	401	05.4
.65	401	05.4	1.02	317	09.6	1.39	398	05.5
.66	386	06.13	1.03	310	09.9	1.40	398	05.5
.67	375	06.7	1.04	304	10.2	1.41	395	05.7
.68	361	07.4	1.05	398	10.5	1.42	391	05.9
.69	348	08.0	1.06	292	10.8	1.43	388	06.0
.70	335	08.7	1.07	286	11.1	1.44	385	06.2
.71	322	09.3	1.08	280	11.4	1.45	382	06.3
.72	310	09.9	1.09	275	11.6	1.46	379	06.5
.73	298	10.5	1.10	269	11.9	1.47	376	06.6
.74	286	11.1	1.11	264	12.2	1.48	373	06.8
.75	275	11.6	1.12	258	12.5	1.49	370	06.9
.76	264	12.2	1.13	253	12.7	1.50	367	07.1
.77	253	12.7	1.14	250	12.9	1.51	364	07.2
.78	242	13.3	1.15	245	13.1	1.52	361	07.4
.79	232	13.8	1.16	240	13.4	1.53	359	07.5
.80	231	13.8	1.17	235	13.6	1.54	356	07.6
.81	221	14.3	1.18	231	13.8	1.55	353	07.8
.82	212	14.8	1.19	226	14.1	1.56	350	07.9
.83	202	15.2	1.20	222	14.3	1.57	348	08.0
.84	193	15.7	1.21	217	14.5	1.58	345	08.2
.85	184	16.1	1.22	213	14.7	1.59	343	08.3
.86	425	04.2	1.23	209	14.9	1.60	340	08.4
.87	417	04.6	1.24	204	15.2	1.61	337	08.6
.88	408	05.0	1.25	200	15.3	1.62	335	08.7
.89	400	05.4	1.26	196	15.5			
.90	392	05.8	1.27	192	15.7			

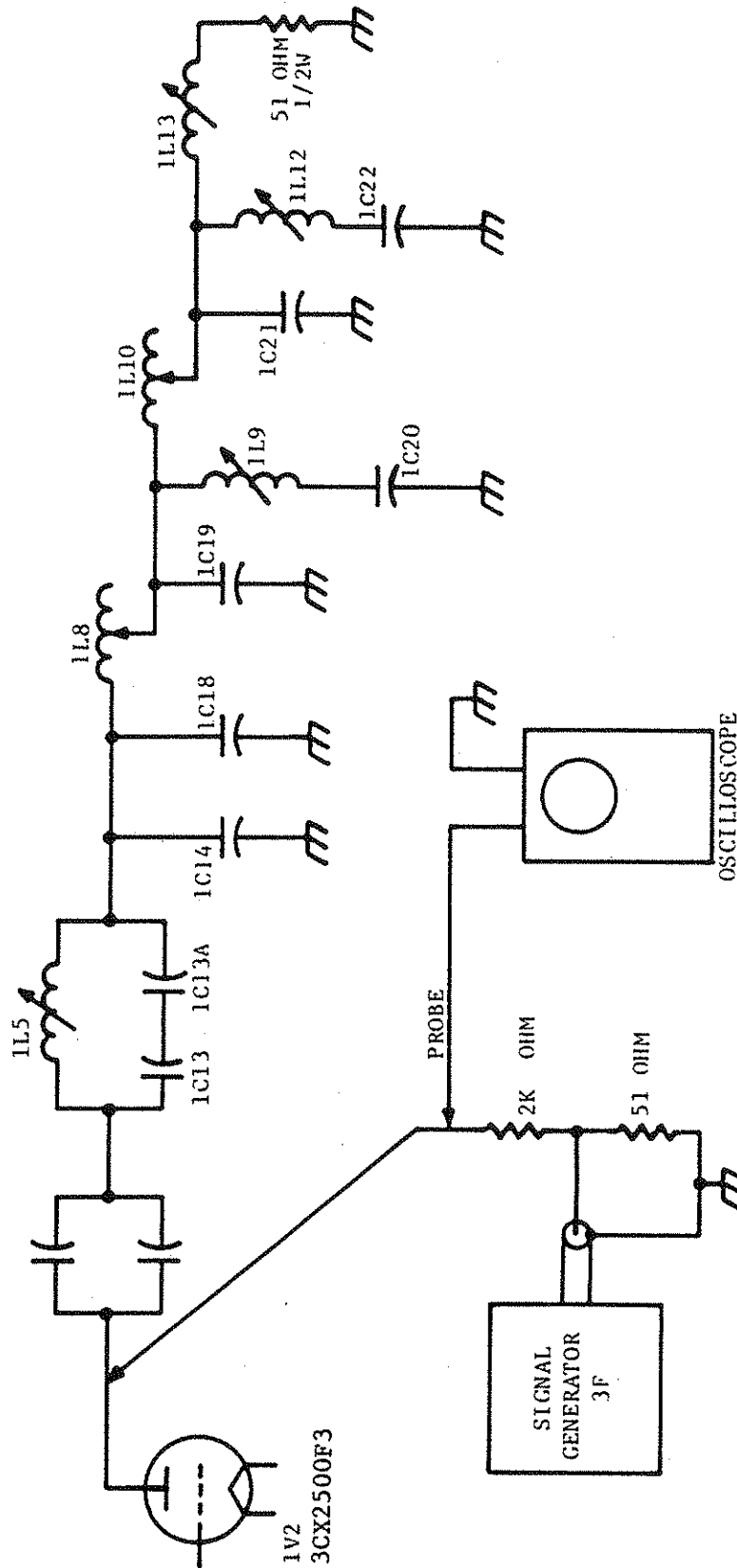

Figure 5-3. Setting 3rd Harmonic Resonator

Refer to figure 5-4. Adjust the tap on coil 1L8 and the roller of coil 1L13 to give an impedance at the plate of  $+j 1350$  ohms.

5-56. Short the output terminal. Refer to figure 5-5. The impedance into the plate of the PA should be positively reactive 1350 ohms, with a very small series-resistive component. If the reactance is negative or substantially lower than 1350 ohms, there are not enough active turns in coil 1L10 and the tap must be moved to increase the number of active turns until the correct setting is achieved.

5-57. Remove the short from the output terminal of the transmitter. The impedance at the plate of the PA tube should then be measured at the carrier frequency. Move the tap on coil 1L8 and the roller of coil 1L13 to obtain  $1350 \pm j0$ .

5-58. Short the output terminal. Measure the positive reactance at the PA tube plate.

5-59. Repeat the process until a reactance of  $1350 \pm j0$  is obtained.

5-60. Retune the signal generator to three times the carrier frequency ( $3f$ ) and check coil 1L5 for parallel reactance.

5-61. The following presentation is a method of a rough tune-up that may be used if impedance measuring equipment is not available.

**WARNING**

DISABLE PRIMARY POWER TO THE TRANSMITTER. USE GROUNDING HOOK TO DISCHARGE ANY RESIDUAL POTENTIAL FROM ALL EXPOSED COMPONENTS BEFORE TOUCHING THEM. ALSO SHORT ANODE OF PA TUBE AND CENTER TAP OF PA FILAMENT TRANSFORMER 1T3.

- a. Necessary equipment will be as follows:
  1. Signal Generator with several clip leads.
  2. Oscilloscope with a low-capacity probe.
  3. Several composition type resistors including a 51-ohm 1/2-watt resistor.
- b. Check that the correct frequency determined components are installed. Refer to figure 8-5.
- c. Adjust 2nd and 3rd Harmonic Traps as outlined elsewhere in this section.



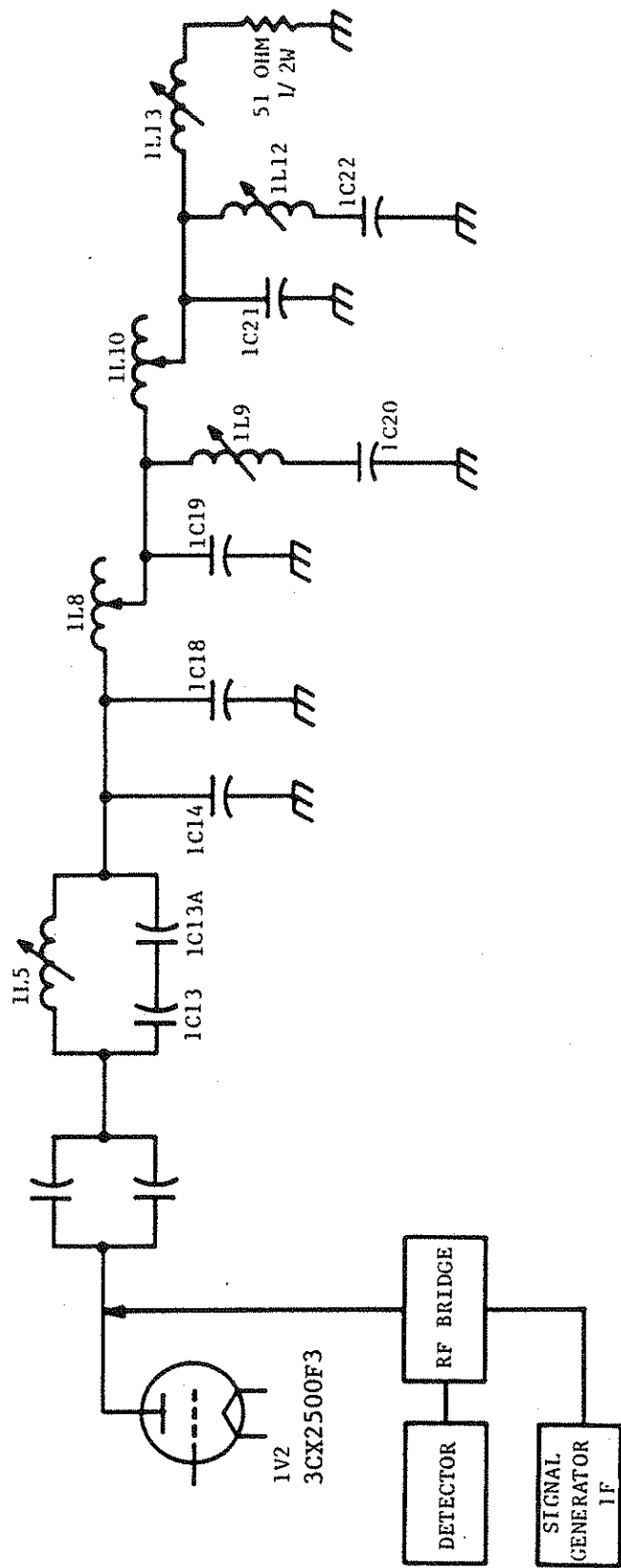

Figure 5-4. Set Up for Output Network Test

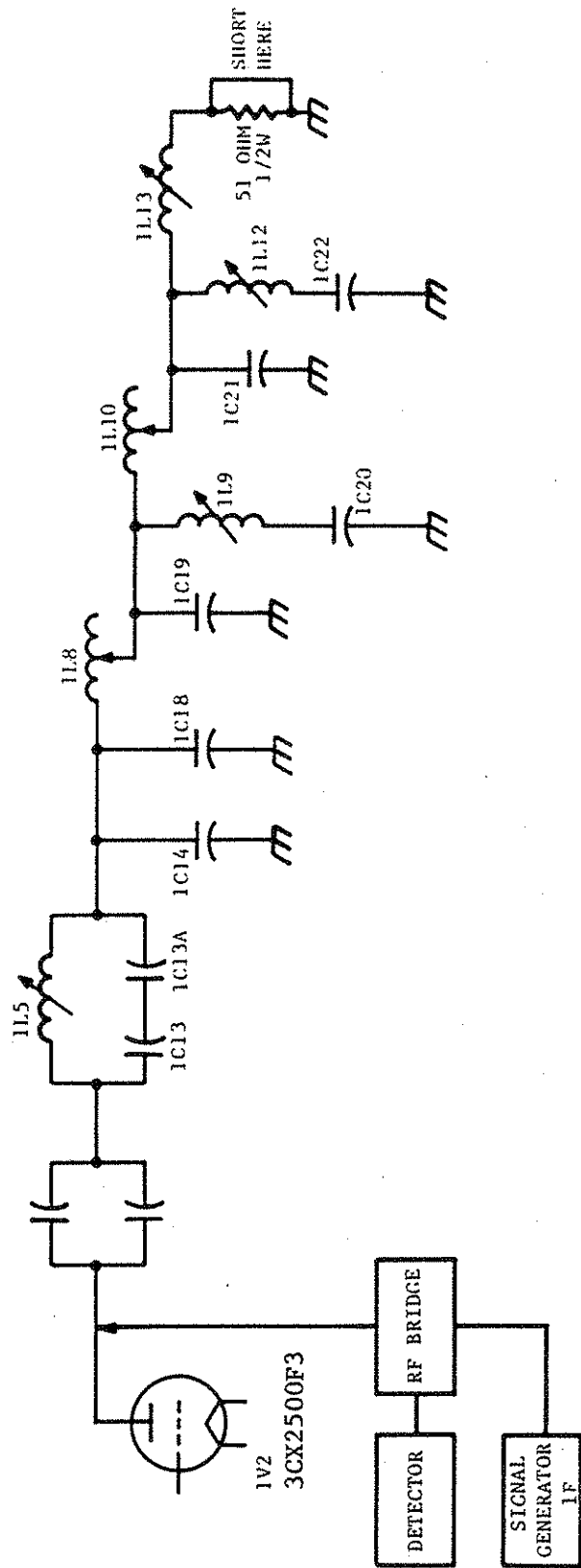

Figure 5-5. Phase Shift Test

- d. Connect the 51-ohm 1/2-watt resistor at the output of the transmitter.
- e. Refer to figure 5-3 and connect the test equipment as outlined.
- f. Position the tap on coil 1L10 to a point that will allow from 1/2 to 2/3 of the coil to be active.
- g. Position the tap on coil 1L8 to a point that will allow from 2/3 to 3/4 of the coil to be active.
- h. Adjust to 3 times (3f) the operating frequency and adjust PLATE EFFICIENCY RESONATOR coil 1L5 for a maximum indication on the oscilloscope.
- i. Tune the signal generator precisely to the operating frequency (1f) and adjust the tap position of coil 1L8 to obtain maximum deflection on the oscilloscope. Fine-tune with PA TUNE capacitor 1C14.
- j. Adjust the gain of the oscilloscope and/or the output attenuator of the signal generator to obtain a convenient deflection on the oscilloscope of 4 major divisions.
- k. Move the oscilloscope probe to a position to read the voltage at the 51-ohm 1/2-watt resistor connected to the transmitter output. Refer to figure 5-6. The oscilloscope reading at this point should be 0.78 major divisions if the loading is correct, if so no further loading adjustment is needed.
- l. If the loading is less than 0.78 major divisions, adjust PA LOAD coil 1L13 to increase the active turns of the coil by one turn. Do not change the setting of capacitor 1C14. Resonate the plate circuit and observe the oscilloscope reading. If a 0.78 major division reading is obtained the loading is correct and no further loading adjustment is needed.
- m. If the loading is greater than 0.78 major divisions, adjust PA LOAD coil 1L13 to decrease the active turns of the coil by one turn. Do not change the setting of capacitor 1C14. Resonate the plate circuit and observe the oscilloscope reading.
- n. Repeat steps m. and n. as necessary to obtain a 0.78 major division indication on the oscilloscope.

5-62. Complete the following steps to check the output network for the correct phase shift.

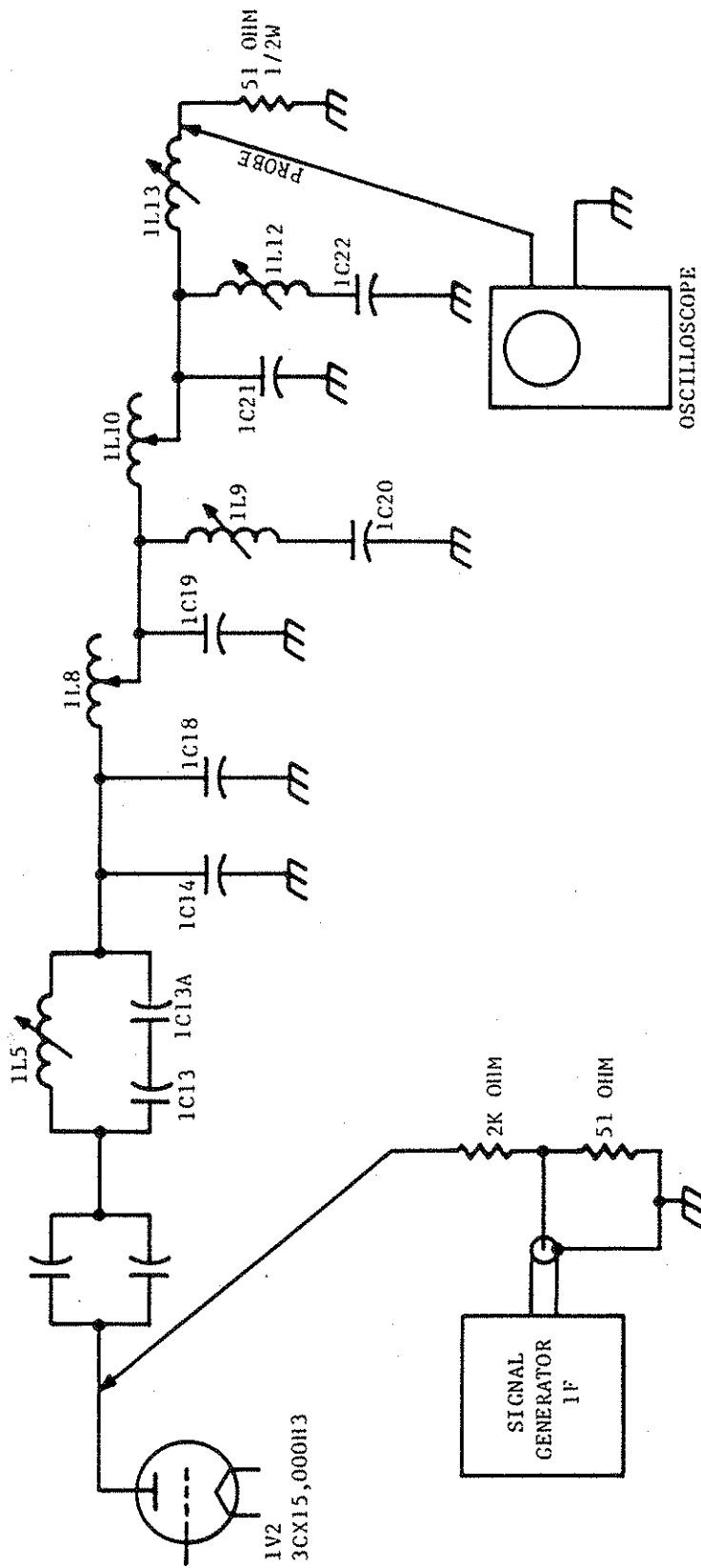

Figure 5-6. Ratio of Load Voltage to Plate Voltage Test

#### NOTE

During this procedure the 2k-ohm resistor is used as a standard of measurement therefore it must be as close to 2k ohms as possible.

- a. Set the deflection on the oscilloscope to 4 major divisions, peak-to-peak.
- b. Place a short across the 51-ohm 1/2-watt resistor installed at the transmitter output. Refer to figure 5-6. With the signal generator set at the carrier frequency (1f), the peak-to-peak indication on the oscilloscope should be 5.5 major divisions.
- c. If the indication on the oscilloscope is substantially less than 5.5 major divisions, there are not enough active turns in 1L10.
- d. Increase the active turns in coil 1L10 and repeat the steps outlined in paragraph 5-61.
- e. Repeat step b.
- f. Repeat steps b., c., d., e. and f. until a 5.5 major division indication is observed on the oscilloscope.
- g. Recheck the 3rd Harmonic Resonator tuning as outlined previously in this section.

5-63. If the frequency is to be changed, it will be necessary to use impedance measuring equipment to adjust the antenna coupling equipment. This is true even in the case of one single non-directional tower with a simple T network coupled to a coaxial transmission line.

5-64. If capacitor 1A3C12A, 1A3C12B, or 1A3C12C has to be replaced, as a result of a defective part or a frequency change, refer to figure 8-10 for the correct replacement capacitor. Refer to figure 5-7 for a rough tune-up test set up. The following procedure should be followed for the test.

**WARNING**

USE THE GROUNDING HOOK TO DISCHARGE ANY RESIDUAL POTENTIAL FROM ALL OF THE EXPOSED COMPONENTS BEFORE TOUCHING THEM.

- a. The following equipment will be needed to accomplish this adjustment.
  1. Signal generator.

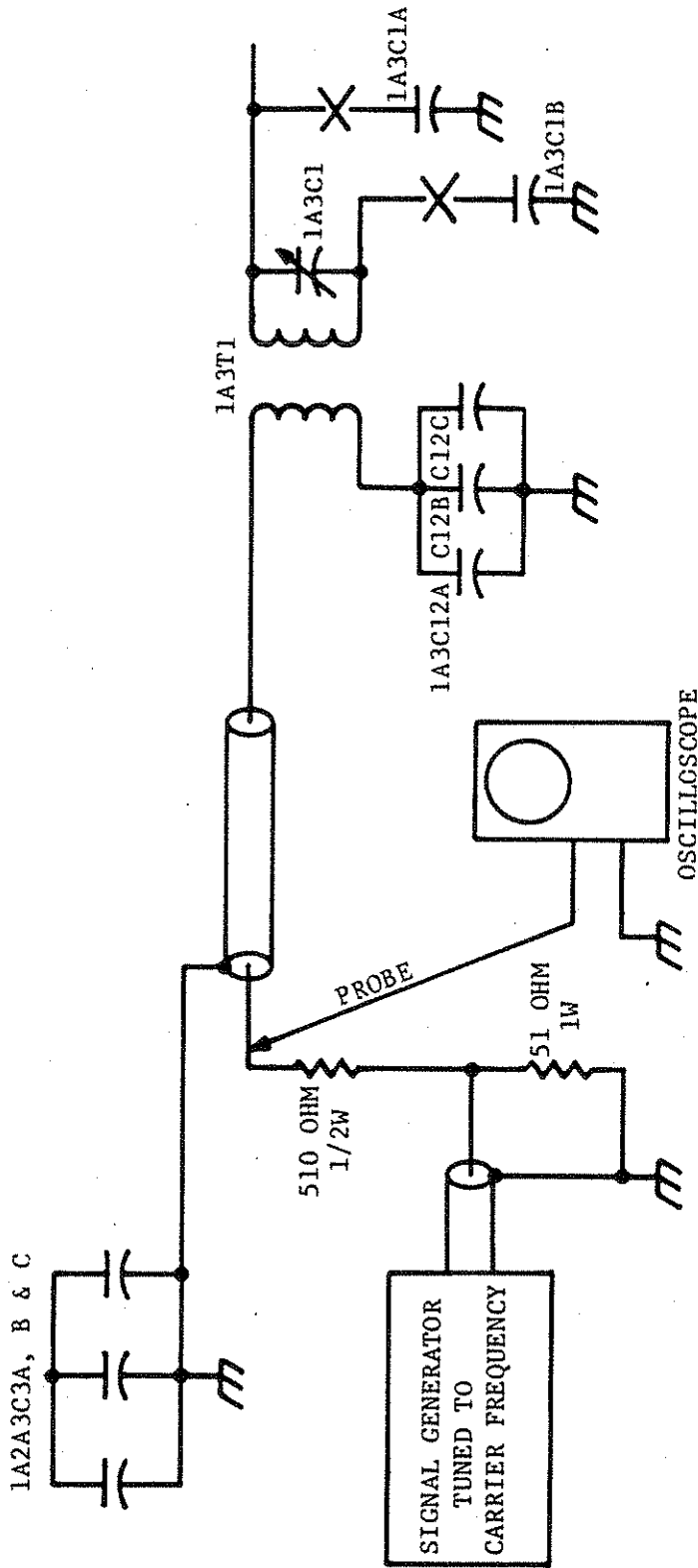

Figure 5-7. Rough Tune-Up Test Set-Up

2. Oscilloscope with a low-capacity probe.
  3. A 510-ohm 1/2-watt and a 51-ohm 1 watt resistor.
  4. Several clip leads.
- b. Check that the correct frequency determined components are installed. Refer to figure 8-10.
  - c. Connect the equipment and resistors as shown in figure 5-7.
  - d. Accomplish the following disconnects.
    1. Disconnect the center conductor of coaxial cable that connects rf driver to 1A3T1 transformer. Make disconnect at the rf driver end.
    2. Disconnect capacitors 1A3C1A, 1A3C1B, and 1A3C1C (if used) from the secondary of transformer 1A3T1.
  - e. Tune the signal generator to the carrier frequency being used.
  - f. A minimum deflection on the oscilloscope will indicate that the correct frequency determined capacitors are installed.
  - g. Reconnect the components disconnected in step d.

5-65. The following procedure should be followed if it becomes necessary to adjust capacitor 1A3C1 as a result of replacing the PA tube or in the case of a frequency change.

**WARNING**

USE THE GROUNDING HOOK TO DISCHARGE ANY  
RESIDUAL POTENTIAL FROM ALL OF THE EX-  
POSED COMPONENTS BEFORE TOUCHING THEM.

- a. The following equipment will be needed to accomplish this adjustment.
  1. Signal generator.
  2. Oscilloscope with a low-capacity probe.
  3. A 510-ohm 1/2-watt and a 51-ohm 1 watt resistor.
  4. Several clip leads.
- b. Check that the correct frequency determined components are installed. Refer to figure 8-5.

- c. Accomplish the following disconnect.
  1. Disconnect the center conductor of coaxial cable that connects rf driver to transformer 1A3T1. Make disconnect at the rf driver end.
- d. Tune the signal generator precisely to the operating frequency and connect it to the input of the coaxial cable, rf driver to transformer 1A3T1, at the rf driver end.
- e. Connect the oscilloscope probe to the grid of the PA tube.
- f. Adjust GRID TUNE capacitor 1A3C1 for a maximum deflection on the oscilloscope.
- g. Connect the oscilloscope probe to the PA tube anode.
- h. Adjust GRID TUNE capacitor 1A3C1 for a maximum deflection on the oscilloscope.
- i. Adjust NEUT capacitor 1A3C3 for a minimum deflection on the oscilloscope.
- j. Repeat steps e., f., g., h. and i. as necessary.

5-66. The following procedure should be followed if it becomes necessary to adjust NEUT capacitor 1A3C3 during routine maintenance or after a PA tube replacement.

**WARNING**

USE THE GROUNDING HOOK TO DISCHARGE ANY  
RESIDUAL POTENTIAL FROM ALL OF THE EX-  
POSED COMPONENTS BEFORE TOUCHING THEM.

- a. The following test equipment will be needed for this adjustment.
  1. Oscilloscope with a low-capacity probe.
  2. A clip lead.
- b. Depress HIGH VOLTAGE OFF and FILAMENT OFF pushbutton switches and remove the left rear transmitter panel.

**WARNING**

USE THE GROUNDING HOOK TO DISCHARGE ANY  
RESIDUAL POTENTIAL FROM ALL OF THE EX-  
POSED COMPONENTS BEFORE TOUCHING THEM.



- c. Connect the oscilloscope probe to modulation monitor sample BNC jack 1A11J1 located on the lower left section of the modulation monitor base plate. Run probe cable to the outside of the transmitter, connect to the oscilloscope and reinstall the transmitter door.
- d. Lower the RF Driver and Overload 1A2 panel, located on lower, right, front panel of transmitter.
- e. Connect the clip lead from terminal 5 (figure 2-2 sheet 5), located on the right rear upper face of the oscillator board, to chassis ground.
- f. Depress FILAMENT ON pushbutton switch.
- g. Adjust NEUT capacitor 1A3C3 for a minimum indication on the oscilloscope.
- h. Adjust GRID TUNE capacitor 1A3C1 for a maximum indication on the oscilloscope.
- i. Repeat steps g. and h. as necessary.
- j. Depress HIGH VOLTAGE OFF and FILAMENT OFF pushbutton switches and remove the left rear transmitter panel.

**WARNING**

USE THE GROUNDING HOOK TO DISCHARGE ANY RESIDUAL POTENTIAL FROM ALL OF THE EXPOSED COMPONENTS BEFORE TOUCHING THEM.

- k. Disconnect the oscilloscope lead, disconnect the clip lead from terminal 5, reinstall the rear transmitter panel, raise and secure RF Driver and Overload 1A2 panel.

5-67. The following procedure should be followed if it becomes necessary to adjust GRID EFFICIENCY capacitor 1A3C2 and inductor coil 1A3L1 after a component change or a frequency change.

**WARNING**

USE THE GROUNDING HOOK TO DISCHARGE ANY RESIDUAL POTENTIAL FROM ALL EXPOSED COMPONENTS BEFORE TOUCHING THEM.

- a. The following test equipment will be needed for this adjustment.
  1. Signal generator.
  2. Oscilloscope with a low-capacity probe.
  3. A 5.1k-ohm 1/2-watt resistor and a 1 ohm 1 watt resistor.
- b. Connect the signal generator, the oscilloscope, and the resistors as shown in figure 5-8.
- c. Tune signal generator to three times the carrier frequency (3f).
- d. Adjust GRID EFFICIENCY capacitor 1A3C2 to half-mesh.
- e. Adjust tap on coil 1A3L1 for maximum deflection on the oscilloscope. Retighten the clamp.
- f. Adjust GRID EFFICIENCY capacitor 1A3C2 for maximum deflection on the oscilloscope.
- g. Disconnect test equipment.

#### 5-68. OSCILLATOR, IPA, AND RF DRIVER ALIGNMENT

5-69. The following procedure should be followed for Oscillator, IPA, and RF Driver alignment after a frequency determining component has been replaced or the carrier frequency of the transmitter has been changed.

#### NOTE

If transmitter frequency change is required, refer to figure 8-5 for the required frequency determined components.

- a. The following test equipment may be needed for this adjustment.
  1. Several lengths of number 20 wire shielded with plastic insulation.
  2. Oscilloscope with a low-capacitance probe.
  3. A clip lead.
  4. Nonconductive, hexagon, adjusting tool to fit coil 1A2A3L1.
  5. Multimeter (Simpson 260 or equivalent).

5-70. OSCILLATOR ALIGNMENT. The following procedure should be followed to check alignment of the oscillator section after a frequency determined component or the carrier of the transmitter has been changed.

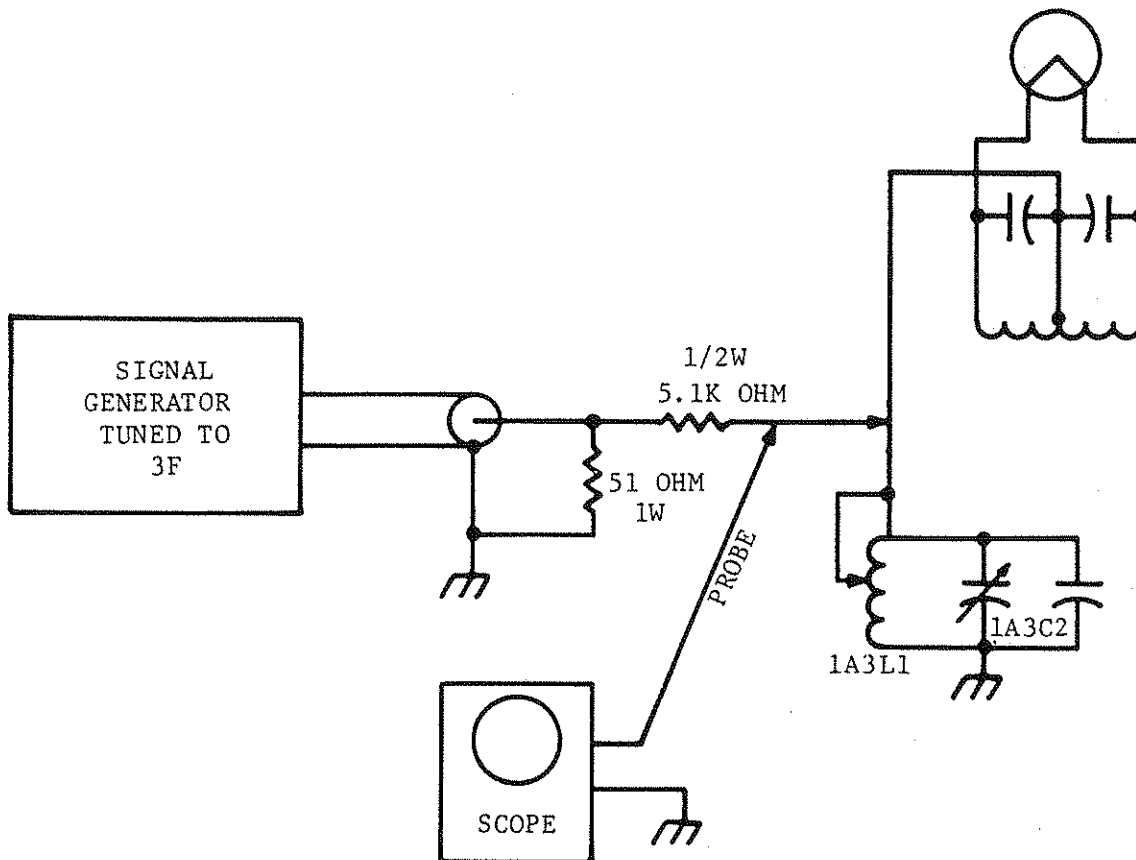

- 1) ADJUST 1A3C2 TO HALF MESH
- 2) ADJUST TAP ON 1A3L1 FOR MAXIMUM OSCILLOSCOPE DEFLECTION
- 3) ADJUST 1A3C2 FOR MAXIMUM DEFLECTION

Figure 5-8. Adjustment of Grid Efficiency Capacitor 1A3C2

- a. Open 1A2 Oscillator/Amp-Fault and Overload front panel.
- b. Depress HIGH VOLTAGE OFF and FILAMENT OFF pushbutton switches.

**WARNING**

USE THE GROUNDING HOOK TO DISCHARGE ANY  
RESIDUAL POTENTIAL FROM ALL EXPOSED  
COMPONENTS BEFORE TOUCHING THEM.

- c. Ensure that the correct frequency determined components are installed. Refer to figure 8-5 for correct components.
- d. Ensure that correct jumpers are installed on terminals 6, 7, 8, and 9 for the selected operating frequency.
  1. Below 1251 kHz, jumper 9 to 7 and 8 to 6.
  2. Above 1251 kHz, jumper 8 to 9.
- e. Connect the clip lead from terminal 5 (figure 2-2 sheet 5), located on the right rear portion of oscillator board, to chassis ground.
- f. Open the RF Driver interlocked panel.

**WARNING**

USE THE GROUNDING HOOK TO DISCHARGE ANY  
RESIDUAL POTENTIAL FROM ALL EXPOSED  
COMPONENTS BEFORE TOUCHING THEM.

- g. Remove RF Driver fuses 1A2A3F1 through F5.
- h. Close and latch the RF Driver interlocked panel.
- i. Depress FILAMENT ON pushbutton switch.
- j. Set oscillator selector switch (figure 3-9) to the number 1 oscillator.
- k. Check the collector of transistor 1A2A1Q3 for 4.5 to 5.5 peak-to-peak of a semi-squared wave at the crystal frequency.
- l. Check terminal 8 on the printed-circuit board for basic crystal frequency divided by 4 below 1251 kHz or by 2 above 1251 kHz.

- m. Adjust oscillator trim capacitor 1A2A1C1 through full-range and verify sustained oscillation.
- n. Set the oscillator selector switch to the number 2 oscillator and repeat steps k. and l.
- o. Adjust oscillator trim capacitor 1A2A1C7 through full-range and verify sustained oscillation.
- p. Depress FILAMENT OFF pushbutton switch.
- q. Connect oscilloscope lead to terminal 3 on Oscillator/Amp board.
- r. Depress FILAMENT ON pushbutton switch.
- s. Use the nonconductive hexagon adjusting tool and adjust coil 1A2A3L1 slug leading edge just into the coil turns.
- t. Read oscilloscope pattern, it should be a 30-volt p-p sine wave.
- u. Fine tune IPA input inductor 1A2A3L1 for a 30-volt p-p sine wave.
- v. Depress FILAMENT OFF pushbutton switch.
- w. Disconnect oscilloscope lead from terminal 3.
- x. Disconnect the clip lead connected to terminal 5.

5-71. IPA TUNING. The following procedure should be followed to check alignment of the IPA section after a frequency determined component or the carrier frequency of the transmitter has been changed.

- a. Depress FILAMENT OFF pushbutton switch.
- b. Connect the clip lead from terminal 5 (figure 2-2 sheet 5) located on the right rear portion of oscillator board, to chassis ground.
- c. Open the RF Driver interlocked panel.

**WARNING**

USE THE GROUNDING HOOK TO DISCHARGE ANY  
RESIDUAL POTENTIAL FROM ALL EXPOSED  
COMPONENTS BEFORE TOUCHING THEM.

- d. Reinstall fuse 1A2A3F1 on the IPA board.
- e. Adjust potentiometer 1A2A3R4 fully counterclockwise.

- f. Connect oscilloscope to terminal 3 (input end of coil 1A2A3L2).
- g. Operate the MULTIMETER selector switch to IPA-1 position.
- h. Route oscilloscope leads to outside of the transmitter and close IPA-RF driver panel.
- i. Depress FILAMENT ON pushbutton switch.
- j. The MULTIMETER indication should be between 0.8 and 1.0 amperes.
- k. If the MULTIMETER indication in step j. was within the 0.8 to 1.0 ampere range, disregard step l., m., n., o, and p. If, however, the indication was not within the 0.8 to 1.0 ampere range, continue with steps l., m., n., o, and p. until the indication does fall within the desired ampere range.
- l. Depress FILAMENT OFF pushbutton switch.
- m. Open IPA-RF Driver panel.

**WARNING**

USE THE GROUNDING HOOK TO DISCHARGE ANY  
RESIDUAL POTENTIAL FROM ALL EXPOSED  
COMPONENTS BEFORE TOUCHING THEM.

- n. Loosen coil 1A2A3L2 slug retaining bar and move the slug into or out of the coil (as necessary) a small amount. Tighten retaining bar.
- o. Close IPA-RF Driver panel.
- p. Depress FILAMENT ON pushbutton switch.
- q. Observe the waveform displayed on the oscilloscope screen at this time. The waveform must be symmetrical, 30-volt p-p with slight ringing. If it is not symmetrical it will be necessary to replace the transistors in the IPA. If the replacement of transistors is accomplished, the complete IPA tuning procedure must be repeated.
- r. Adjust potentiometer 1A2A3R4 fully clockwise.
- s. The multimeter indication should be between 1.0 and 1.2 amperes and the oscilloscope indication should be a 30-volt p-p square wave with a slight ringing. If the multimeter and the oscilloscope indications are not correct, repeat steps l., m., n., o., p., q., and r., until correct indications are obtained.

- t. Verify that duty cycle is symmetrical and does not shift. If the duty cycle shifts, readjust coil 1A2A3L2 slug on IPA to correct this problem or select different transistors for the IPA. It is very important that proper symmetry is achieved at this point in order to obtain best performance from the driver transistors. Follow the appropriate sections of this procedure for this adjustment.
- u. Depress FILAMENT OFF pushbutton switch.
- v. Disconnect the clip lead from terminal 5.

5-72. RF DRIVER CHECK. The following procedure should be followed to check the rf driver section after a frequency determined component or the carrier frequency has been changed.

- a. Depress HIGH VOLTAGE OFF pushbutton switch.
- b. Depress FILAMENT OFF pushbutton switch.

**WARNING**

DISCONNECT AND LOCK OUT STATION POWER  
TO THE TRANSMITTER.

- c. Remove front, lower right panel by removing the six cross-recessed head screws.

**WARNING**

USE THE GROUNDING HOOK AND DISCHARGE  
RESIDUAL POTENTIAL FROM ANY EXPOSED  
COMPONENTS BEFORE TOUCHING THEM.  
SPECIAL ATTENTION SHOULD BE GIVEN TO  
THE CAPACITORS ON THE POWER SUPPLY  
BOARD 1A5.

- d. Replace the front, lower right panel using the six cross-recessed head screws.
- e. Open the RF Driver interlocked panel.

**WARNING**

USE THE GROUNDING HOOK AND DISCHARGE RESIDUAL POTENTIAL FROM ANY EXPOSED COMPONENTS BEFORE TOUCHING THEM.

NOTE

No attempt should be made to adjust the slug rack for coils 1A2A3L3 through L6 unless the the grid circuitry of the 3CX2500F3 PA tube is correctly adjusted.

- f. Reinstall fuse 1A2A3F2 on the RF Driver board.
- g. Operate MULTIMETER selector switch to RF DVR I position.
- h. Loosen side attaching screws slightly and move coils 1A2A3L3 through L6 slug rack until all four slugs are out of the coils. Tighten side attaching screws.
- i. Connect the oscilloscope probe to output terminal 3 of A2 module.
- j. Close the RF Driver interlocked panel.
- k. Connect the clip lead from terminal 5 (figure 2-2 sheet 5), located on the right rear portion of oscillator board, to chassis ground.
- l. Enable station power to the transmitter.
- m. Depress FILAMENT ON pushbutton switch.
- n. Adjust GRID TUNE control for maximum drive.
- o. Verify output of A2 module connected to the oscilloscope for at least 40V square wave with slight ringing and 50 percent duty cycle.
- p. Depress FILAMENT OFF pushbutton switch.
- q. Repeat steps e., f., (remove fuse 1A2A3F2 and install fuse 1A2A3F3), g., h., j., (connect the oscilloscope probe to A3 module), k., l., m., n., o., p., and q. for A3 module.
- r. Repeat step q. for A4 and A5 modules.
- s. Depress FILAMENT OFF pushbutton switch.



**WARNING**

USE THE GROUNDING HOOK TO DISCHARGE ANY RESIDUAL POTENTIAL FROM ALL EXPOSED COMPONENTS BEFORE TOUCHING THEM.

- t. Open the RF Driver interlocked panel. Disconnect the oscilloscope probe and reinstall all of the rf driver fuses, 1A2A3F2 through 5.
- u. Tighten the side retaining screws on coils 1A2A3L3 through 6 slug rack. Close and secure the RF Driver interlocked panel.
- v. Depress FILAMENT ON pushbutton switch.
- w. The MULTIMETER indication should be between 8.0 and 8.5 amperes. The desired PA grid current is 250 to 300 mA. If these parameters are not achieved, adjust coil 1A2A3L3 through L6 slug rack until the parameters are achieved. Follow the appropriate sections of this procedure while adjusting the slug rack.
- x. As a final check, connect the oscilloscope probe to each module, A2 through A3, in turn, to ensure that a square wave with a symmetrical duty cycle is presented on the oscilloscope screen for each module. Follow the appropriate steps for opening and securing the RF Driver interlocked panel.
- y. Alternately adjust GRID TUNE control and coil 1A2A3L3 through L6 slug rack for maximum GRID current while ensuring that rf driver current does not exceed 8.5 amperes and that IPA current is between 1.0 and 1.2 amperes. Driver current should be lower at low frequencies and toward higher values at high frequencies.
- z. Depress FILAMENT OFF pushbutton switch.
- aa. Disconnect the clip lead from terminal 5.

NOTE

Desired final results of driver tuning should provide over 250 milliamperes grid current, less than 8.5 amperes driver current, and 1.0 ampere IPA current.

5-73. CARRIER FREQUENCY CHECK

5-74. The following procedure should be accomplished for a Carrier Frequency check.

- a. Connect a frequency counter to monitor output test jack 1J1 (figure 2-5). If frequency is not correct, adjust capacitor 1A2A1C1, located on oscillator/amplifier board, for correct carrier frequency. Set oscillator selector switch to oscillator 2 position and adjust capacitor 1A2A1C7 for correct carrier frequency.

NOTE

The FCC permits no more than  $\pm 20$  Hz frequency deviation.

5-75. EFFICIENCY TUNING

5-76. The following is a procedure for the Efficiency Tuning check.

**WARNING**

USE EXTREME CAUTION WHEN INSERTING PROBE THROUGH THE PA ENCLOSURE SCREEN. DANGEROUS HIGH VOLTAGE IS PRESENT IN THE ENCLOSURE.

- a. Place the oscilloscope probe through the top screen approximately 1 inch into the PA enclosure. Depress HIGH VOLTAGE ON pushbutton switch, adjust PA PLATE EFFICIENCY RESONATOR control 1L5, for a maximum efficiency reading on the power meter and correct waveform as shown in figure 5-9.
- b. Depress HIGH VOLTAGE OFF pushbutton switch.
- c. Depress FILAMENT OFF pushbutton switch.

5-77. OVERLOAD CHECKS AND ADJUSTMENTS

5-78. The transmitter circuitry has the following overload protections in addition to the fuses and circuit breakers. Refer to figure 8-6 and 8-8.

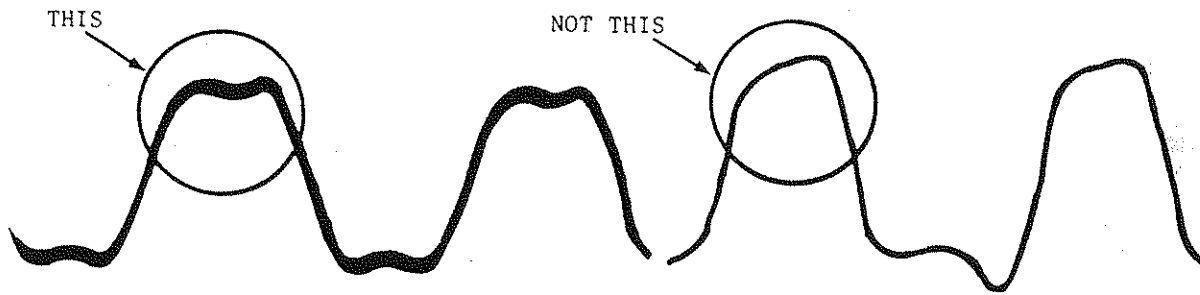

Figure 5-9. Correct Power Amplifier Waveform Requirements

- a. ARC. Senses the firings of the spark gaps in the PDM filter circuitry.
- b. MOD. Senses overcurrent from the modulation screen supply.
- c. VSWR. Senses a rise in amplitude of the reflected wave at the rf output.
- d. DISS. Compares the positive feedback sample derived from the rf voltage across tank capacitor 1C14 to a negative voltage generated by the HV supply current passing through resistor 1R17.
- e. DC. Senses the HV supply current passing through resistor 1R17.

NOTE

ARC and MOD protection circuitry do not have sensitivity adjustments.

- f. HIGH-VOLTAGE FAULT. Senses phase imbalance in the High-Voltage Transformer.

5-79. The following is a procedure for checking the ARC protection circuitry.

- a. Depress HIGH VOLTAGE OFF pushbutton switch.
- b. Depress FILAMENT OFF pushbutton switch.
- c. Connect a volt/ohm meter from terminal 13 on Fault and Overload printed-circuit board 1A2A2 to ground. Reading should be 10 ohms. Disconnect meter leads.
- d. Depress FILAMENT ON pushbutton switch.
- e. Depress HIGH VOLTAGE ON pushbutton switch.
- f. Connect one end of a clip lead to terminal 2, line side of Oscillator/Amp 1A2A1 fuse F1.
- g. Momentarily tap terminal 13 on Fault and Overload 1A2A2 printed-circuit board with the other end of the clip lead.
- h. Observe the ARC fault indicator LED, located on the RH transmitter meter panel. It should be momentarily illuminated and the plate voltage to the PA tube should be momentarily interrupted.
- i. Disconnect the clip lead.
- j. Depress the HIGH VOLTAGE OFF pushbutton switch.
- k. Depress the FILAMENT OFF pushbutton switch.

5-80. The following is a procedure for checking the MOD protection circuitry.

**WARNING**

DISABLE STATION INPUT POWER TO THE TRANSMITTER BEFORE STARTING THIS PROCEDURE.

- a. Remove lower left rear transmitter panel.

**WARNING**

USE THE GROUNDING HOOK TO DISCHARGE ALL EXPOSED COMPONENTS. TOUCH EACH 1T4 TRANSFORMER TAP WITH THE GROUNDING HOOK BEFORE TOUCHING THEM.

- b. Replace grounding hook into its stowed position.
- c. Disconnect wires 7 and 8 from the primary taps of 1T4 transformer. Tag as to location.
- d. Use suitable insulation to cover the exposed wire ends and position the wires so that they do not touch any part of the transmitter.
- e. Reinstall lower left rear transmitter panel.
- f. Lower PDM chassis 1A1 panel.
- g. Adjust HI PWR potentiometer 1A1A2R52 fully counterclockwise. Refer to figure 3-8 for location.
- h. Enable station input power to the transmitter.
- i. Depress FILAMENT ON pushbutton switch.
- j. Depress HIGH VOLTAGE ON pushbutton switch. The HIGH VOLTAGE ON pushbutton switch light will illuminate but no high voltage will be applied to the transmitter.
- k. Adjust HI PWR potentiometer 1A1A2R52 slowly clockwise until modulator screen overload occurs. MOD fault indicator LED 1A9DS5, located on the right hand meter panel, should illuminate when screen current is in the range of 0.50 to 0.70 amperes.
- l. Depress the RESET pushbutton switch.

- m. Depress HIGH VOLTAGE OFF pushbutton switch.
- n. Depress FILAMENT OFF pushbutton switch.

**WARNING**

DISABLE STATION INPUT POWER TO THE  
TRANSMITTER BEFORE OPENING REAR TRANS-  
MITTER DOOR.

- o. Remove lower left rear transmitter panel.

**WARNING**

USE THE GROUNDING HOOK TO DISCHARGE ALL  
EXPOSED COMPONENTS. TOUCH EACH 1T4  
TRANSFORMER TAP WITH THE GROUNDING HOOK  
BEFORE TOUCHING THEM.

- p. Remove the temporarily installed insulation from wires 7 and 8.
- q. Reconnect wires 7 and 8 to the correct 1T4 transformer taps as tagged in step c.
- r. Ensure that the grounding hook is in its stowed position.
- s. Reinstall lower left rear transmitter panel.

5-81. The following is a procedure for checking the VSWR overload sensitivity circuitry.

- a. Depress the FILAMENT OFF pushbutton switch and the HIGH VOLTAGE OFF pushbutton switch.
- b. Remove right-hand meter panel for access to the directional coupler retaining screws.
- c. Remove the four directional coupler retaining screws, remove the Directional Coupler from the panel (do not disconnect any wires), invert the Directional Coupler, reinstall it in the panel, and secure it in place with the four retaining screws.
- d. Select REFLECTED position on the POWER METER selector switch.
- e. Adjust HI POWER potentiometer 1A1A2R52 fully counterclockwise. Refer to figure 3-8 for location.
- f. Depress the FILAMENT ON pushbutton switch.

- g. Depress the HIGH VOLTAGE ON pushbutton switch.
- h. Adjust HI POWER potentiometer 1A1A2R52 slowly clockwise until VSWR fault indicator illuminates. POWER meter should indicate very close to 600 watts.
- i. If the POWER meter does not indicate very close to 600 watts when VSWR fault indicator illuminates, adjust VSWR trip sensitivity potentiometer 1A2A2R32. Refer to figure 3-9 for location.
- j. Repeat steps h. and i. until VSWR fault indicator illuminates at very close to 600 watts indication on the POWER meter.
- k. Depress HIGH VOLTAGE OFF pushbutton switch.
- l. Depress FILAMENT OFF pushbutton switch.
- m. Reinstall Directional Coupler in its original position.

5-82. The following is a procedure for checking the DC overload sensitivity circuitry.

- a. Depress FILAMENT ON pushbutton switch.
- b. Depress HIGH VOLTAGE ON pushbutton switch.
- c. Adjust for desired output power. Modulate 100 percent with a 20 Hz tone.
- d. Adjust DC OVERLOAD rheostat 1A4R9 clockwise until transmitter power trips off. Refer to figure 3-5 for location of rheostat 1A4R9. Adjust rheostat 1A4R9 counterclockwise one-sixteenth turn.
- e. Depress HIGH VOLTAGE OFF pushbutton switch.
- f. Depress FILAMENT OFF pushbutton switch.

5-83. The following is a procedure for checking the HV Transformer Protection sensitivity:

- a. Modulate the transmitter at 100 percent with 100-120 Hz. Adjust the GAIN control to the threshold of tripping, then adjust counterclockwise three (3) turns. If an audio generator was not available for modulating the transmitter, leave the Gain control set as far clockwise as possible without the circuit tripping under normal modulation conditions.

5-84. The following is a procedure for checking the DISS limiter sensitivity circuitry.

- a. Depress FILAMENT ON pushbutton switch.

- b. Depress HIGH VOLTAGE ON pushbutton switch.
- c. Adjust the desired output power. Modulate 100 percent with a 20 Hz tone.
- d. Adjust DISS limiter sensitivity potentiometer 1A1A2R38 counter-clockwise until transmitter trips off. Refer to figure 3-8 for location of 1A1A2R38. Adjust 1A1A2R38 clockwise one-sixteenth turn.
- e. Depress FILAMENT OFF pushbutton switch.
- f. Depress HIGH VOLTAGE OFF pushbutton switch.

5-85. AIR PRESSURE SWITCH SENSITIVITY

5-86. The following is a procedure for checking and readjusting air pressure sensitivity switch 1A41S1.

- a. Depress HIGH VOLTAGE OFF pushbutton switch.
- b. Depress FILAMENT OFF pushbutton switch.

**WARNING**

SET THE MAIN AC DISCONNECT CIRCUIT BREAKER TO OFF. USE THE GROUNDING HOOK TO DISCHARGE ANY RESIDUAL POTENTIAL FROM ALL COMPONENTS BEFORE TOUCHING THEM.

- c. Release the two lower fasteners on the lower right rear panel and prop the lower edge of the panel open approximately one inch.
- d. Depress FILAMENT ON pushbutton switch.
- e. Blower 1A41B1 should run but relay 1A4K6 should not energize.
- f. If relay 1A4K6 energizes, remove lower rear panel, locate air pressure sensitivity switch 1A41S1 and adjust the sensitivity of switch 1A41S1 slightly. Refer to figure 2-2 sheet 4.
- g. Repeat steps c, d, f, and g. until relay 1A4K6 does not energize with the panel open at the lower edge approximately one inch.
- h. Depress FILAMENT OFF pushbutton switch.
- i. Latch the two lower fasteners on the lower rear panel.
- j. Depress FILAMENT ON pushbutton switch.



k. The relay 1A4K6 should latch. If it does not, repeat the appropriate steps of this section until the relay does not latch with the panel propped open approximately one inch but will latch when the panel is closed and securely fastened.

l. Depress FILAMENT OFF pushbutton switch.

#### 5-87. ELECTRICAL ZERO OF PLATE VOLTAGE METER

5-88. The PA plate volt meter has been electrically zeroed at the factory; however, if its zero point is changed due to component replacement or accidental adjustment, the following method is used to re-zero the meter.

#### WARNING

DISABLE STATION POWER TO THE TRANSMITTER BEFORE PROCEEDING WITH THIS ADJUSTMENT.

a. Zero the plate voltage meter mechanically by adjusting the mechanical zero on the meter.

#### WARNING

USE GROUNDING HOOK TO DISCHARGE RESIDUAL POTENTIAL FROM ALL EXPOSED COMPONENTS BEFORE TOUCHING THEM.

b. Open AC Power Panel 1A4 (lower panel of front right hand section of transmitter cabinet).

c. Remove lower wire (number 61) from circuit breaker 1A4CB9. Insulate the lug end of the wire and position it in such a manner so that it cannot touch ground or any component.

d. Close and securely latch the AC Power Panel.

e. Adjust HI PWR potentiometer 1A1A2R52, located on the PDM control printed-circuit board, maximum counterclockwise (zero-power output). Refer to figure 3-8 for location.

f. Enable primary ac power to the transmitter.

g. Depress FILAMENT ON pushbutton switch.

h. Depress HIGH VOLTAGE ON pushbutton switch.

NOTE

There should be no power output.

- i. Zero the PLATE VOLTAGE meter using PLATE VOLTAGE METER ELECTRICAL ADJUST potentiometer 1A9R1 located behind the right hand meter panel cover. Refer to figure 3-3.
- j. Depress the HIGH VOLTAGE OFF and FILAMENT OFF pushbutton switches.

**WARNING**

DISABLE STATION POWER TO THE TRANSMITTER BEFORE PROCEEDING WITH THIS ADJUSTMENT.

- k. Open AC Power Panel.

**WARNING**

USE GROUNDING HOOK TO DISCHARGE RESIDUAL POTENTIAL FROM ALL EXPOSED COMPONENTS BEFORE TOUCHING THEM.

- l. Reconnect wire number 61 to circuit breaker 1A4CB9.
- m. Close and securely latch the AC Power Panel.
- n. Enable station primary ac power to the transmitter.
- o. Depress FILAMENT ON pushbutton switch.
- p. Depress HIGH VOLTAGE ON pushbutton switch.
- q. Adjust HI PWR potentiometer 1A1A2R52, located on the PDM printed-circuit board, for the required full power output.
- r. Depress HIGH VOLTAGE OFF pushbutton switch.
- s. Depress FILAMENT OFF pushbutton switch.

5-89. AUDIO INPUT/PDM CONTROL FEEDBACK BOARD

5-90. Adjust the controls as follows prior to starting an alignment/adjustment procedure.

- a. INPUT GAIN potentiometer R11 fully CCW.

- b. CMRR potentiometer R66 fully CW.
- c. HUM NULL potentiometer R29 fully CCW.
- d. DISS LIMITER potentiometer R38 fully CW.
- e. CARRIER SHIFT potentiometer R35 midrange.
- f. LO POWER AUDIO potentiometer R42 midrange.
- g. MODULATION TRACKING potentiometer R41 midrange.
- h. HI POWER potentiometer R52 fully CCW.
- i. LOW POWER potentiometer R53 fully CCW.
- j. BESSEL FILTER IN/OUT switch set to the OUT position.

5-91. AUDIO BOARD ALIGNMENT. Ensure board controls are adjusted as outlined in paragraph 5-91. Accomplish the following steps for alignment:

- a. Apply power to the transmitter and depress FILAMENT ON pushbutton switch.
- b. Check for the following voltages:
  - 1. Transistor Q3 emitter, 14.0  $\pm$ 1.0V.
  - 2. Transistor Q4 emitter, -14.0  $\pm$ 1.0V.
- c. Jumper terminals G and H together and drive against ground using a low-distortion oscillator with an output impedance of 600 ohms, or less.
- d. Connect an oscilloscope to pin 8 of integrated circuit U1C.
- e. Adjust the oscillator output to 0 dBm at 60 Hz and adjust CMRR potentiometer R66 for null. Null depth must be greater than 60 dB.
- f. Remove jumper wire from between terminals G and H.
- g. Drive terminals G and H with a balanced sinusoidal signal at 0dBm, 300 Hz and adjust MODULATION TRACKING potentiometer R41 for a null at pin 7 and 8 of integrated circuit U3.
- h. Energize relay K1 by switching to transmitter LOW POWER.
- i. Adjust LO POWER AUDIO potentiometer R42 for a null at pin 7 and 8 of integrated circuit U3.

5-92. Audio Board Adjustment. Ensure board controls are adjusted as outlined in paragraph 5-89. Accomplish the following steps for adjustment:

- a. Complete normal transmitter start-up procedures, with no audio applied.
- b. Depress POWER HIGH pushbutton switch and adjust HI POWER potentiometer R52 CW until normal high operating power is attained.
- c. Depress POWER LOW pushbutton switch and adjust LO POWER potentiometer R53 CW until normal low operating power is attained.
- d. With the transmitter operating in HIGH POWER configuration, apply +10 dB 300 Hz sinusoidal audio signal to the transmitter input and adjust INPUT GAIN potentiometer R11 for 100% modulation.
- e. Alternately remove and apply the +10 dB 300 Hz audio input signal while adjusting CARRIER SHIFT potentiometer R35 for no change in the carrier level, as indicated on the station modulation monitor.
- f. Reduce the +10 dB 300 Hz audio input level until 90% modulation is indicated on the station modulation monitor.
- g. Connect a Volt/Ohm meter to pin 10 of integrated circuit U3 (under the tab) and adjust MODULATION TRACKING potentiometer R41 for 0.0 Vdc indication on the meter.
- h. While monitoring the station modulation monitor, alternately depress POWER HIGH pushbutton switch and POWER LOW pushbutton switch. If modulation level changes more than 1% for a 20% change in power level, adjust MODULATION TRACKING potentiometer R41 CW. Potentiometer R41 will vary absolute modulation levels, therefore it will be necessary to readjust audio input level/-INPUT GAIN potentiometer R11. This will be an iterative process which will require careful, deliberate adjustments.
- i. Apply a +10 dB 300 Hz sinusoidal audio signal to the transmitter input and adjust INPUT GAIN potentiometer R11 for 100% modulation.
- j. Depress POWER LOW pushbutton switch and adjust LO POWER AUDIO potentiometer R42 for 100% modulation.
- k. With no audio signal applied to the transmitter and plug P1 in jack J1 in any position, adjust HUM NULL potentiometer R29 CW until a dip in noise measurement is noted. If noise increases or no dip is observed, adjust potentiometer R29 fully CCW and reposition plug P1 to another position in jack J1. Repeat the procedure until a dip in noise measurement is noted. It is possible that no dip will be observed in any position of plug P1.

1. With modulation on and transmitter operating in the HIGH POWER mode, refer to paragraph 5-84 and adjust DISS LIMITER potentiometer R38 as outlined in the procedure.

5-93. Bessel Filter Adjustment. The bessel filter, as supplied with the Audio Board, has a 15k-ohm resistor network (R19), which will significantly reduce overshoot without affecting transmitter frequency response. The 15k-ohm network may be replaced with a 22k-ohm, 27k-ohm, 33k-ohm, or 39k-ohm network, thus further reducing overshoot and move the transmitter's  $f_{-3\text{ dB}}$  down in frequency. The optimum network value will be determined by the station audio processing equipment and station format requirements.

5-94. Low-Frequency -3 dB Point Adjustment. With inadequate processing, dc overloads or erratic supply current may present a problem. If carrier shift under modulation is severe, check the output of the processing equipment with a dc coupled oscilloscope. The resulting oscilloscope base line should be steady. If the base line oscillates, adjust the station processing equipment. If, however, the processing equipment cannot be adjusted to produce a steady base line, capacitor C45 should be replaced with a lesser value to correct the problem.

#### 5-95. DISTORTION MINIMIZATION

5-96. Systematic adjustment as outlined in the following steps will normally result in a significant reduction of distortion products generated by the transmitter.

- a. Adjust plate tuning, plate efficiency resonator, grid tuning, and grid efficiency resonator with no modulation in accordance with the procedure outlined in paragraph 2-27 t. through w.
- b. Modulate the transmitter into the normal load (antenna) to 95 percent positive or negative, whichever comes first, at 400 Hz. Measure and note harmonic distortion.
- c. Adjust the following controls for minimum total harmonic distortion (THD):
  1. MOD SCN VOLTAGE HI POWER potentiometer 1A4R10.
  2. AUX MOD ADJUST potentiometer 1A1R3.
  3. AUX DRIVER ADJUST potentiometer 1A1A3R8.
- d. Because of interaction between controls, repeat step c. as required for minimum THD.
- e. Change the audio generator output frequency to 5 kHz and modulate the transmitter to 95 percent positive. Measure and note THD and PA TUNE control dial reading. Adjust the PA TUNE control for minimum THD and again note distortion and dial reading. Turn the PA TUNE control counterclockwise until the halfway point, between

the two distortion limits or dial readings, is reached. Then adjust PLATE EFFICIENCY RESONATOR control for minimum THD.

- f. Check THD at 95 percent modulation with audio generator output frequencies of 500 Hz, 1 kHz, 2.5 kHz, and 5 kHz. If a difference in THD distortion greater than 0.5 percent is observed at any of the intermediate frequencies, it may be necessary to repeat steps b. through e., using slightly different control settings, to lower the average distortion across the frequency band.
- g. It may be possible to further reduce distortion at 5 kHz through adjustment of the AUX MOD ADJUST potentiometer. This control will not show a clear THD null at high audio frequencies. This control should be adjusted to the point where THD is just on the "edge" of increasing. After adjustment, THD should be once again checked at 400 Hz and compared with previous results. In some transmitters, a slight tradeoff in midband distortion is necessary in order to reduce high-frequency distortion.
- h. A small adjustment of GRID EFFICIENCY control capacitor 1A3C2 may lower THD slightly. Leave the control set just to the "edge" of a THD increase, but in no case should adjustment allow the PA plate/cathode voltage to increase 50 volts (1/2 division) above the dip obtained originally.
- i. Switch the transmitter to low power and modulate to 95 percent at 400 Hz. Adjust MOD SCN VOLTAGE LO POWER potentiometer for minimum THD.

SECTION VI  
TROUBLESHOOTING

6-1. GENERAL

6-2. This section contains troubleshooting instructions for the HARRIS MW-5B AM BROADCAST TRANSMITTER.

6-3. Prior to starting a troubleshooting procedure check all switches, power cord connections, connecting cables, and power fuses.

6-4. TECHNICAL ASSISTANCE

6-5. HARRIS Technical and Troubleshooting assistance is available from HARRIS Field Service during normal business hours (8:00 AM - 5:00 PM Central Time). Emergency service is available 24 hours a day. Telephone 217/222-8200 to contact the Field Service Department or address correspondence to Field Service Department, HARRIS CORPORATION, Broadcast Transmission Division, P.O. Box 4290, Quincy, Illinois 62305-4290, USA. The HARRIS factory may also be contacted through a TWX facility (910-246-3212) or a TELEX service (247319).

6-6. Separate paragraphs are provided for common trouble symptoms. Included within these paragraphs are lists of the most probable causes of the trouble, and where it is not otherwise obvious, the required corrective action. Included in this section are paragraphs covering the following symptoms:

<u>SYMPTOM</u>	<u>PARAGRAPH</u>
TRANSMITTER TOTALLY INOPERATIVE	6-7
TRANSMITTER FILAMENT AND LOW VOLTS FAILS TO STAY ON	6-8
HIGH VOLTAGE ON FUNCTION INOPERATIVE	6-9
HIGH VOLTAGE IMMEDIATELY SHUTS DOWN WHEN PLATE ON PUSHBUTTON SWITCH DEPRESSED	6-10
NO RF OUT WITH GRID DRIVE, FILAMENTS, AND HV SUPPLY NORMAL	6-11
POOR OR NO MODULATION CAPABILITY	6-12
POOR PERFORMANCE	6-13
OVERLOAD SHUTDOWNS	6-14
MODULATION ENHANCER MALFUNCTION	6-15
RF OSCILLATOR MODULE 1A2A1 MALFUNCTION	6-15
PDM MODULE 1A1A1 MALFUNCTION	6-17
RF DRIVER 1A2A3 MALFUNCTION	6-19

6-7. TRANSMITTER TOTALLY INOPERATIVE

- a. Loss of local utility service.
- b. Main wall circuit breaker open.
- c. LV SUPPLIES circuit breaker CB5 OFF (located on control panel).
- d. LOCAL/REMOTE switch in wrong position.
- e. Panel interlocks open or ground hooks not on the hangers.
- f. External interlock on terminal board 1TB2 terminal 1 and 2 open. Must have short. Refer to paragraph 2-28.
- g. Loss of 110 Vac control circuit. Circuit breaker CB5, CB3, or CB2, transformer T5 open.

6-8. TRANSMITTER FILAMENT AND LOW VOLTS FAILS TO STAY ON

- a. Thermal cutout of blower motor. Internal to motor.
  1. Belt tension too tight. Refer to figure 2-6 for adjustment.
  2. Blower or motor bearing binding.
  3. Excessive exhaust system back pressure.
- b. Air switch sensitivity problem.
  1. Rear PA panel off or not secure.
  2. Sensor tube restricted.
  3. Sensitivity setting wrong. Refer to paragraph 5-85 for adjustment.
  4. Defective air switch.
    - a) Microswitch 1S1 failed.
    - b) Diaphragm failed.
- c. HOLD circuit of filament contactor not functioning.
  1. Check relay K6 contactor closure, and relay K6 coil continuity.
  2. Circuit breaker CB1, CB4, or CB6 tripped.
    - a) Check filament transformers for shorts.



b) Low voltage power supply failure.

6-9. HIGH VOLTAGE ON FUNCTION INOPERATIVE

- a. Time delay circuit open.
  1. 1A4A1R2 resistor open.
  2. Loss of 30 volts on 1A4A1-8 relay board.
  3. TD1 (HV time delay) heater element open.
- b. Overload circuit holding transmitter in OFF condition.
  1. Overload relays 1A4A1K1 through K4 energized or defective. Refer to figure 8-6 for schematic diagram.
  2. Latching relay 1A4K2 or associated circuitry defective.
    - a) Mechanical latch failure.
    - b) Open 1A4K2 ON coil.
    - c) High voltage ON loop circuit open.
      - 1) 1A4A1TD1 contacts 1A4A1 terminal 12-13.
      - 2) 1A4K2 contacts 1A4A1 terminal 12-6.
      - 3) 1A4A1K2 contacts 1A4A1 terminal 6-3.
      - 4) 1A4A1K1 contacts 1A4A1 terminal 6-3.
      - 5) 1A4K1 contacts on relay terminal 9-10.

6-10. HIGH VOLTAGE IMMEDIATELY SHUTS DOWN WHEN PLATE ON PUSHBUTTON SWITCH DEPRESSED

- a. PDM full on causing dc overload. Refer to paragraph 2-24 step n.
  1. POWER potentiometer R52 on 1A1A2 board turned fully clockwise, on full.
  2. Zener diode 1A1CR1 shorted.
  3. Loss of feedback diodes.
- b. No rf drive. Check rf signal path for failure.
  1. Check that +30-volt LED on oscillator board is illuminated. If not illuminated, refer to table 6-2.

2. Place a clip lead from GND to terminal 5 on 1A2A1 oscillator board.
  - a) Check that RF OUT LED on oscillator board is illuminated. If not, refer to table 6-2.
  - b) Check that indicators DS1-DS5, IPA/driver fault light indicators, are not illuminated.
  - c) Note MULTIMETER readings of IPA I, RF DVR I, and RF DVR V. Refer to figure 2-7.
    - 1) Check for failure in low-voltage power supply 1A5.
3. Adjust GRID TUNE for peak. Refer to figure 2-7.

NOTE

Remove test clip (b2 above) before HI ON pushbutton switch is depressed.

- a) Low-grid current caused by defective diode 1A2A1CR2 on oscillator board.
  - b) Open cathode in PA stage V2.
  - c) Open choke 1A3L2.
  - d) Internal short in PA stage V2.
- c. No mod bias volts.
1. BIAS SUPPLY circuit breaker CB5 tripped.
  2. Bias supply 1A5 component failure.
  3. Audio driver 1A1A3 component failure.
  4. Modulator tube V1 internal short.
- d. Step-start overload sensor triggered. Refer to paragraph 2-25.
- e. Shut down as a result of the HV Protection circuitry.
- f. If the HIGH-VOLTAGE FAULT indicator is illuminated when the HIGH VOLTAGE ON pushbutton switch is depressed, the High-Voltage Transformer may have one of the following faults:
1. Open rectifier.
  2. Open high-voltage secondary winding.

3. Shorted secondary turns in the transformer.
  4. High or low voltage on one phase of incoming power.
- g. Complete the following checks on the transmitter high-voltage power supply:

**WARNING**

DISCONNECT AND LOCK OUT STATION PRIMARY  
POWER TO THE TRANSMITTER.

1. Open the necessary panel/doors to gain access to the transmitter high-voltage power supply.

**WARNING**

USE THE GROUNDING STICK AND DISSIPATE  
ALL RESIDUAL POTENTIALS FROM WIRES,  
TERMINALS, AND COMPONENTS BEFORE  
TOUCHING THEM.

2. Check all secondary screw terminals for tightness, correct lug installation, lock washers under each screw, and correct wire installation into all lugs.
3. Check the high-voltage rectifiers as follows:
  - a) Using an ohmmeter, check each rectifier to ensure that none are open or shorted. In the forward direction, the resistance will typically be 450k ohms (measured on the RX10,000 scale). In the reverse direction, the rectifiers should read open (infinity). Check all rectifier terminals for proper solder connections. Also, check all wires for broken strands of wire. Replace as necessary.

SPECIAL NOTE

IF INFINITY IS INDICATED IN THE FORWARD  
AND THE REVERSE DIRECTION, THE BATTERY  
VOLTAGE OF THE OHMMETER MAY BE LESS  
THAN THE FORWARD VOLTAGE DROP OF THE  
RECTIFIER OR THE RECTIFIER MAY BE OPEN.

- b) An alternate method of testing a high-voltage rectifier is with a small variable power supply as follows:

- 1) Connect the power supply across the rectifier with the positive lead to the anode. Raise the voltage output of the power supply until current is drawn. This will likely occur at approximately 12 volts with rectifier saturation occurring at 15 to 16 volts. In the reverse direction, the rectifier should not draw any current, if the rectifier does draw current, it is defective and should be replaced.
4. Use an ohmmeter and check the balance of dc resistance between the three even numbered and the three odd numbered terminals of the High-Voltage Transformer. A significant difference between the two readings could indicate shorted windings in the transformer.

#### SPECIAL NOTE

OHMMETER CHECKS OF THE TRANSFORMER MAY BE INCONCLUSIVE. THIS IS DUE TO THE HIGH NUMBER OF SECONDARY TURNS VERSUS THE SMALL NUMBER OF SHORTED TURNS REQUIRED TO DISRUPT THE BALANCE OF THE TRANSFORMER OPERATION. THE BEST METHOD OF DETERMINING THAT THE TRANSFORMER IS AT FAULT IS TO RULE OUT OTHER FAULT POSSIBILITIES (RECTIFIERS, WIRING, 3-PHASE POWER).

- h. If the HIGH-VOLTAGE FAULT indicator is still illuminated after all possible transformer and rectifier problems have been eliminated, check to see if the HV Transformer Protection board is erroneously sensing errors. Depress the FILAMENT ON pushbutton switch and then the FAULT RESET pushbutton switch. This should clear the HV FAULT indicator. If not, the HV Protection board will require servicing.
- i. If it is determined that the HV Protection board is not erroneously sensing errors and High Voltage can not be applied to the transmitter, the HV Transformer is at fault. Service/replace the HV transformer.
- j. Restore primary power to the transmitter and depress the FILAMENT ON pushbutton switch.
- k. Depress the transmitter FAULT RESET pushbutton switch. This should extinguish the HIGH VOLTAGE FAULT indicator LED. If not, the HV Voltage Protection board will require servicing and/or readjustment.
- l. If, after determining that the HV Protection Board is not erroneously sensing errors, the high voltage can not be applied to the

transmitter without the HIGH VOLTAGE FAULT indicator illuminating, the problem is most likely the High-Voltage Transformer and it should be serviced or replaced.

6-11. NO RF OUT WITH GRID DRIVE, FILAMENTS, AND HV SUPPLY NORMAL

- a. Malfunction on PDM board 1A1A1.
- b. External PDM "kill" switched on. Check for short between 1TB2-3 (ground) and -17.
- c. Audio driver 1A1A3 component failure.
- d. Check MULTIMETER MOD SCR voltage.
- e. Possible failure of modulator PA tube, 1C12 blocking capacitor, 1L1, 1L2, 1L3.

6-12. POOR OR NO MODULATION CAPABILITY

- a. Inoperative Modulation Enhancer (table 6-1).
- b. Malfunction on input board 1A1A2.
- c. Malfunction on audio driver board 1A1A3.
- d. PDM frequency has drifted.
- e. Defective coil 1L1, 1L2, or 1L3.
- f. PA tube low emission.
- g. Incorrect audio input to transmitter (external).
- h. Modulator tube.

6-13. POOR PERFORMANCE

- a. Poor positive peak capability.
  1. Audio processing equipment not properly adjusted.
  2. Component change or failure on audio input board 1A1A2.
  3. Component change or failure on audio driver board 1A1A3.
  4. HV transformer set on too low a tap.
  5. Low emission modulator tube.
  6. 75 kHz filter coil defective (1L1, 1L2, or 1L3).

7. Modulation monitor out of calibration.
- b. Distortion (audible):
1. Overdriven/improperly adjusted Modulation Enhancer.
  2. Input audio processing equipment fault.
  3. 75 kHz coils 1L1, 1L2, or 1L3 defective.
  4. Efficiency resonators mistuned or changed value.
- c. Distortion (minor, not meeting specs).
1. Input audio processing equipment malfunction.
  2. Modulation Enhancer improperly adjusted.
  3. Resonator improperly adjusted (grid/plate).
  4. 75 kHz oscillator improperly adjusted.
  5. Auxiliary/Driver improperly adjusted.
  6. 75 kHz filter coils 1L1, 1L2, 1L3 defective.
  7. Audio input board 1A1A2 malfunction.
  8. Audio driver board 1A1A3 malfunction.
  9. Modulator tube weak.
  10. Coupling Zener diodes on 1A1A1/1A1A3 defective.
- d. Noise:
1. Improper station equipment grounding.
  2. Open HV filter capacitors 1C1 - 1C15.
  3. 75 kHz oscillator off-frequency.
  4. 3-phase line voltage unbalanced.
  5. Test equipment defective.
- e. Poor PA Efficiency:
1. Grid/Plate resonators mistuned.
  2. Mechanical zero not exactly set on plate voltage/plate current meters.

3. Electrical zero not correctly set on plate voltage meter.
4. Common point/antenna base meter not calibrated.
5. Common point/antenna base impedance changed.

#### 6-14. OVERLOAD SHUTDOWNS

##### a. DC overload:

1. Short in HV supply.
2. Short or arc in PA or modulator plate circuit.
3. DC overload adjusted too sensitive.
4. Short or arc in modulator or PA tube.
5. Arc gap firing.
6. VSWR overload causing a DC overload.

##### b. DC and High-Voltage Fault Overload:

1. If the transmitter trips off but can be restored to operation, it probably indicated a temporary imbalance in the operation of the High-Voltage Power Supply. Possible causes might be one of the following:
  - a) Momentary loss of an ac phase.
  - b) Three-phase line imbalance (changed since adjustment).
  - c) Loose transformer connections.
  - d) Insufficient 1C15 capacitance.
2. If the transformer remains off refer to paragraph 6-10 for corrective action.

##### c. Dissipation overload:

1. Sensitivity adjusted too low.
2. Arc gap firing.
3. Feedback diode breakdown (1A6) possibly only when a particular power level is reached.
4. Instability in PA grid.
5. Mistuned final amplifier.

6. Arc-over inside or outside tubes.
  7. Diode 1A1A2CR2, CR3, CR4, or CR9 defective.
  8. Overmodulation.
  9. Low PA efficiency (PA output network problem).
- d. Modulator screen overload:
1. Arc gap firing.
  2. Internal arc in modulator tube.
  3. Screen supply overload.
  4. Overloaded Zener diode 1A4A1CR1.
- e. VSWR Overload:
1. Capacitor breakdown in output network.
  2. Transmission line breakdown.
  3. Transmission line impedance change.
  4. Lightning.
  5. Antenna coupling unit problems.
  6. Ball gap across tower base fired.

6-15. MODULATION ENHANCER MALFUNCTION

6-16. Refer to table 6-1 for troubleshooting of the Modulation Enhancer.

6-17. RF OSCILLATOR MODULE 1A2A1 MALFUNCTION

6-18. Refer to table 6-2 for troubleshooting of the RF Oscillator module.

6-19. PDM MODULE 1A1A1 MALFUNCTION

6-20. Refer to table 6-3 for troubleshooting of the PDM module.

6-21. RF DRIVER 1A2A3 MALFUNCTION

6-22. Refer to table 6-4 for troubleshooting of the RF Driver.



Table 6-1. Modulation Enhancer 1A1A4 Troubleshooting

TROUBLE SYMPTOM	PROBABLE CAUSE	CORRECTIVE ACTION
POWER indicator DS1 does not illuminate.	<ol style="list-style-type: none"> <li>1. Fuse F1 open.</li> <li>2. Capacitor C1 shorted.</li> <li>3. Transformer T1 shorted.</li> <li>4. Indicator DS1 open.</li> <li>5. One or more diodes CR1 through CR4 shorted.</li> </ol>	<ol style="list-style-type: none"> <li>1. Replace fuse.</li> <li>2. Replace capacitor.</li> <li>3. Replace transformer.</li> <li>4. Replace indicator.</li> <li>5. Replace defective diode(s).</li> </ol>
NEG PEAK adjustment has no effect on negative peak clipping.	<ol style="list-style-type: none"> <li>1. Transistor Q1 or Q2 shorted.</li> <li>2. Diode CR5 shorted.</li> <li>3. Resistor R16 open.</li> </ol>	<ol style="list-style-type: none"> <li>1. Replace defective transistor.</li> <li>2. Replace diode.</li> <li>3. Replace resistor.</li> </ol>
Negative clipping occurs but no indication on LED DS2	<ol style="list-style-type: none"> <li>1. Faulty LED.</li> </ol>	<ol style="list-style-type: none"> <li>1. Replace LED.</li> </ol>
POS PEAK adjustment has no effect on positive peak clipping.	<ol style="list-style-type: none"> <li>1. Transistor Q3 or Q4 shorted.</li> <li>2. Diode CR7 shorted.</li> <li>3. Resistor R2 open.</li> </ol>	<ol style="list-style-type: none"> <li>1. Replace defective transistor.</li> <li>2. Replace diode.</li> <li>3. Replace resistor.</li> </ol>
Positive clipping occurs but no indication on LED DS3.	<ol style="list-style-type: none"> <li>1. Faulty LED.</li> </ol>	<ol style="list-style-type: none"> <li>4. Replace LED.</li> </ol>

Table 6-2. RF Oscillator Module 1A2A1 Troubleshooting

TROUBLE SYMPTOM	PROBABLE CAUSE	CORRECTIVE ACTION
+30-volt indicator DS1 not illuminated.	<ol style="list-style-type: none"> <li>1. Fuse F1 defective.</li> <li>2. 30-volt power supply defective.</li> <li>3. Defective wiring.</li> </ol>	<ol style="list-style-type: none"> <li>1a. Replace defective fuse.</li> <li>2a. Check 30-volt power supply A24. MULTI-METER switch in the 30-VOLT SUPPLY position.</li> <li>3a. Locate and repair defective wiring.</li> </ol>
Oscillator fuse F1 repeatedly opens.	<ol style="list-style-type: none"> <li>1. Shorted transistor Q4, resistor R25, or a short in the +30 Vdc wiring.</li> </ol>	<ol style="list-style-type: none"> <li>1a. Disconnect wire on terminal 3 from the module. Connect a VOM to the circuit side of fuse F1 and check for a resistance greater than 600 ohms.</li> <li>1b. Locate and repair/replace shorted component.</li> </ol>
RF out indicator LED	<ol style="list-style-type: none"> <li>1. Terminal 5 of 1A2A1 not receiving ground from main relay 1K4 when HIGH VOLTAGE pushbutton switch depressed.</li> <li>2. Relay 1A2A1K1 defective.</li> </ol> <p style="text-align: center;">NOTE</p> <p>Test relay K1 by connecting ground to terminal 5 of 1A2A1.</p>	<ol style="list-style-type: none"> <li>1a. Replace relay 1K4.</li> <li>1b. Replace HIGH VOLTAGE pushbutton switch 1A7S5.</li> <li>2. Replace relay 1A2A1K1.</li> </ol>

Table 6-2. RF Oscillator Module 1A2A1 Troubleshooting (Continued)

TROUBLE SYMPTOM	PROBABLE CAUSE	CORRECTIVE ACTION
<p>With oscillator Y1 operating, voltage at the junction of coil L1, resistor R11, diode CR4, and the collector of transistor Q3 is something other than approximately 3 Vdc. Voltage measurements should be approximately +4 to +5 Vdc when oscillator Y1 is removed.</p>	<p>3. Crystal Y1 defective.</p> <p>4. Defective oscillator component.</p> <p>1. Integrated circuit U1 defective.</p>	<p>3a. Replace crystal Y1.</p> <p>4a. Test oscillator and replace defective component.</p> <p>1a. Connect the positive VOM lead to the junction of coil L1, resistor R17, diode CR4, and transistor Q3 and the negative lead to chassis ground. Voltage measurement should be approximately 3 Vdc to 5Vdc with oscillator Y2 removed. If voltage is incorrect, remove divider integrated circuit U1 and repeat measurement. Replace divider integrated circuit U1 if voltage is correct.</p>
<p>With oscillator Y1 operating, voltage to terminal E10 on the module is something other than approximately +1.25 to +1.75 Vdc. Voltage measurement should be either approximately -0.2 Vdc or +2.5 to +3.5 Vdc when oscillator Y1 is removed.</p>	<p>1. Integrated circuit U1 defective.</p>	<p>1a. Connect the positive VOM lead to terminal E10 and the negative lead to chassis ground. Voltage measurement should be approximately +1.5 Vdc (or 0.1 Vdc to +3 Vdc with oscillator Y1 removed). If voltage is incorrect, replace divider integrated circuit U1.</p>

Table 6-2. RF Oscillator Module 1A2A1 Troubleshooting (Continued)

TROUBLE SYMPTOM	PROBABLE CAUSE	CORRECTIVE ACTION
<p>Emitter bias voltage incorrect.</p>	<p>2. Defective output stage component.</p> <p>1. Defective transistor Q4 or associated circuit.</p>	<p>2a. Locate and replace defective output stage components.</p> <p>1a. Perform check of emitter bias voltage of transistor Q4. Voltage measurement should be approximately +6 to +10 volts. Replace defective transistor.</p>

Table 6-3. PDM Module 1A1A1 Troubleshooting

TROUBLE SYMPTOM	PROBABLE CAUSE	CORRECTIVE ACTION
<p>NOTE</p> <p>These procedures are based upon the results of an oscilloscope check for the waveforms shown in figure 8-4.</p>		
<p>No waveform at collector of transistor Q5; waveform present at collector of transistor Q3.</p>	<ol style="list-style-type: none"> <li>1. Fuse 1A1F1 open.</li> <li>2. 39-volt Zener diode 1A1CR1 defective.</li> <li>3. Transistor 1A1A1Q4 or Q5 defective.</li> <li>4. Zener diode CR4 and/or CR5 shorted.</li> </ol>	<ol style="list-style-type: none"> <li>1. Replace fuse 1A1F1.</li> <li>2. Replace Zener diode 1A1CR1.</li> <li>3. Replace defective transistor.</li> <li>4. Replace defective Zener diode.</li> </ol>
<p>No waveform at collector of Q3; waveform present at junction or resistors R7, R8 and capacitor C8.</p>	<ol style="list-style-type: none"> <li>1. Transistor 1A1A1Q3 defective.</li> <li>2. Loss of drive from high/low power adjust circuit.</li> </ol>	<ol style="list-style-type: none"> <li>1. Replace transistor.</li> <li>2. Check power circuit on 1A1A2 and replace defective component.</li> </ol>
<p>No waveform at junction of resistors R7, R8, R9.</p>	<ol style="list-style-type: none"> <li>1. Transistor 1A1A1Q1 or Q2 defective.</li> <li>2. Diode 1A1A1CR1 or CR2 open or shorted.</li> </ol>	<ol style="list-style-type: none"> <li>1. Replace defective transistor.</li> <li>2. Replace defective diode.</li> </ol>

Table 6-4. RF Driver 1A2A3 Troubleshooting

TROUBLE SYMPTOM	PROBABLE CAUSE	CORRECTIVE ACTION
<p style="text-align: center;">NOTE</p> <p style="text-align: center;">For any failure symptom, e.g., no or low grid drive or a fault light indication, make oscilloscope checks for waveforms in accordance with figure 8-1.</p>		
<p>No sine wave at junction of capacitor 1A2A3C1 and resistor A1R1</p> <p>No square wave at collector of transistor Q1.</p>	<ol style="list-style-type: none"> <li>1. Shorted capacitor C1.</li> <li>2. Shorted transformer T1.</li> <li>1. Fuse F1 open.</li> <li>2. Transistor Q1 or Q2 shorted.</li> <li>3. Resistor A1R1, A1R2 or capacitor A1C1, A1C2 shorted.</li> <li>4. Transformer T1 assembly defective.</li> </ol>	<ol style="list-style-type: none"> <li>1. Replace capacitor.</li> <li>2. Replace transformer assembly.</li> <li>1. Replace fuse (if fuse continues to open, check for other probable causes).</li> <li>2. Replace defective transistor.</li> <li>3. Replace defective resistor or capacitor.</li> <li>4. Replace defective transformer assembly.</li> </ol>
<p style="text-align: center;">NOTE</p> <p style="text-align: center;">A VOM is used to make power checks.</p>		
<p>60-80 Vdc power not present at collector of transistor Q2 and 30-40 Vdc is not present at collector of transistor Q1.</p>	<ol style="list-style-type: none"> <li>1. Fuse F1 open.</li> <li>2. Transistor Q1 or Q2 shorted.</li> <li>3. Resistor 1A2A3R3, or 1A2A3R4 open.</li> </ol>	<ol style="list-style-type: none"> <li>1. Replace fuse F1.</li> <li>2. Replace defective transistor.</li> <li>3. Replace defective resistor.</li> </ol>

## SECTION VII

### PARTS LIST

#### 7-1. INTRODUCTION

7-2. This section provides a description, reference designator, and order number for replaceable electrical parts and assemblies, and selected mechanical parts necessary for proper maintenance of the HARRIS MW-5B AM BROADCAST TRANSMITTER. Table 7-1 lists the assemblies having replaceable parts, the number of the table listing the parts, and the page number on which the table is located. Indenture of the assembly nomenclature in table 7-1 signifies the equipment level within the overall equipment configuration.

#### NOTE

Actual component values may vary slightly from component values listed on schematics and parts lists. Due to industry-wide shortages, it is sometimes necessary to use parts other than those specified. In every case, however, a substitute part is selected for conformance to overall design specifications so that equipment performance is not affected. Components that are frequency determined or peculiar to the individual transmitter are identified by a HARRIS part number and MW-5B AM BROADCAST TRANSMITTER component number on the final test and addendum sheets shipped with the transmitter.

#### 7-3. REPLACEABLE PARTS SERVICE

7-4. Replacement parts are available 24 hours a day, seven days a week from the HARRIS Service Parts Department. Telephone 217/222-8200 to contact the service parts department or address correspondence to Service Parts Department, HARRIS CORPORATION, Broadcast Transmission Division, P.O. Box 4290, Quincy, Illinois 62305-4290, USA. The HARRIS factory may also be contacted through a TWX facility (910-246-3212) or a TELEX service (247319).

Table 7-1. REPLACEABLE PARTS LIST INDEX

TABLE NO.	UNIT NOMENCLATURE	PART NO.	PAGE
7-2	XMTR MW5B 5KW	994 8622 001	7-3
7-3	MW5B (BASIC) XMTR	994 8622 002	7-4
7-4	PDM-CHASSIS-1A1	992 5948 001	7-7
7-5	PDM PC BOARD	992 3813 001	7-8
7-6	PC BD XFMRLESS AND INPUT	992 5934 001	7-9
7-7	AUDIO DRIVER	992 3815 001	7-12
7-8	PC ASSY ME1	992 4474 001	7-13
7-9	RF AND OVERLOAD	992 3816 002	7-14
7-10	OSCILLATOR	992 3817 001	7-15
7-11	RF DRIVER, 1A2A3	992 3819 002	7-17
7-12	RF DRIVER MODULE	992 3820 001	7-18
7-13	FLAG/OVERLOAD PC	992 4962 002	7-19
7-14	PA GRID, ISO PLATE	992 3821 002	7-21
7-15	AC POWER PANEL, 1A4	992 3822 002	7-22
7-16	RELAY OVERLOAD BD	992 4961 001	7-23
7-17	POWER SUPPLY, 1A5	992 4032 002	7-24
7-18	LEFT METER PANEL 1A7	992 3825 002	7-25
7-19	DIRECTIONAL COUPLER	992 3826 001	7-26
7-20	RT MRT PANE	992 3827 001	7-27
7-21	HV RECTIFIER	992 4036 001	7-28
7-22	MOD SCR PS/MOD MON	992 4033 001	7-29
7-23	METER MULTIPLIER	938 4433 004	7-30
7-24	PWB, HV PROTECTION MW5/10	992 6396 001	7-31



Table 7-2. XMTR MW5B 5KW - 994 8622 001

REF. SYMBOL	HARRIS PART NO.	DESCRIPTION	QTY	UM
1V1	374 0074 000	TUBE 4CX3000A/8169	1.0	
1V2	374 0093 000	TUBE 3CX2500F3	1.0	
	994 8622 002	MW5B (BASIC) XMTR	1.0	

Table 7-3. MW5B (BASIC) XMTR - 994 8622 002

REF. SYMBOL	HARRIS PART NO.	DESCRIPTION	QTY	UM
1A1	992 5948 001	PDM-CHASSIS-1A1	1.0	
1A2	992 3816 002	RF AND OVERLOAD	1.0	
1A3	992 3821 002	PA GRID, ISO PLATE	1.0	
1A4	992 3822 002	AC POWER PANEL, 1A4	1.0	
1A5	992 4032 002	POWER SUPPLY, 1A5	1.0	
1A6	992 3824 001	FEEDBACK DETECTOR	1.0	
1A7	992 3825 002	LEFT METER PANEL 1A7	1.0	
1A8	992 3826 001	DIRECTIONAL COUPLER	1.0	
1A9	992 3827 001	RT MRT PANEL	1.0	
1A10	992 4036 001	HV RECTIFIER	1.0	
1A11	992 4033 001	MOD SCR PS/MOD MON	1.0	
1A12	929 1979 001	ASSY, GRD SWITCH	1.0	
1B1	436 0196 000	MOTOR 110/220V 50HZ	1.0	
1CR1,1CR2,1CR3	384 0567 000	DIODE, UNITRODE		
1CR4,1CR5,1CR6				
1CR7,1CR8,1CR9				
1CR10,1CR11				
1CR12,1CR13				13.0
1CR14	384 0020 000	RECTIFIER IN4005	1.0	
1CR15,1CR16	384 0639 000	RECTIFIER UFS10		
1CR17				3.0
1C1	510 0706 000	CAP 2.90 UF 20KV	1.0	
1C2,1C3	508 0345 000	CAP .47UF 200V 10%	2.0	
1C4	500 0477 000	CAP .01UF 10% 2500V	1.0	
1C5	504 0383 000	CAP 1500PF 25KV	1.0	
1C6	524 0314 000	CAP 50UF 450V	1.0	
1C8	504 0383 000	CAP 1500PF 25KV	1.0	
1C10	504 0248 000	CAP. MICA 750PF 20KV	1.0	
1C11,1C12	516 0402 000	CAP 4800 PF 20KV	2.0	
1C14	514 0145 000	CAP VAR 25-500PF	1.0	
1C15	510 0706 000	CAP 2.90 UF 20KV	1.0	
1C16,1C17	516 0207 000	CAP HV 25 UUF 15KV	2.0	
1C23	516 0082 000	CAP, DISC .01UF 1KV GMV	1.0	
1C24,1C25	500 0833 000	CAP, MICA 390PF 500V 5%	2.0	
1C26	500 0783 000	CAP 5100 PF 500V 5%	1.0	
1C27,1C28	516 0082 000	CAP, DISC .01UF 1KV GMV	2.0	
1DS1,1DS2	396 0111 000	LAMP 6W 6S6DC130	2.0	
1E2	560 0041 000	ARRESTER, VOLT SURGE	1.0	
1E8	927 7092 001	CARBON BLOCK ASSY	1.0	
1J1,1J2	620 0410 000	JACK, BULKHEAD UG-657/U	2.0	
1L1	939 0076 001	COIL ASSEMBLY	1.0	
1L2	939 0076 002	COIL ASSEMBLY	1.0	
1L3	939 0076 003	COIL ASSEMBLY	1.0	
1L4	939 0012 001	COIL ASSEMBLY	1.0	
1L5	939 0129 001	COIL ASSEMBLY	1.0	
1L6,1L7	938 9963 001	COIL ASSEMBLY	2.0	
1L9	492 0309 000	INDUCTOR VAR 28UH	1.0	
1L10	931 6138 047	COIL FXD 26FB2843	1.0	

Table 7-3. MW5B (BASIC) XMTR - 994 8622 002 (Continued)

REF. SYMBOL	HARRIS PART NO.	DESCRIPTION	QTY	UM
1L11	938 0503 001	COIL ASSY MOD MON PI	1.0	
1L12	938 3192 001	RIBBON TYPE COIL	1.0	
1L13	942 3236 001	COIL ASSY BC10P	1.0	
1R1	540 0587 000	RES 100.0 OHM 2W 5%	1.0	
1R3,1R4	540 0563 000	RES 10.0 OHM 2W 5%	2.0	
1R5	540 0685 000	RES 1.2M OHM 2W 5%	1.0	
1R6	540 0073 000	RES 10.0K OHM 1/2W 5%	1.0	
1R7	542 0207 000	RES 50.0 OHM 50W	1.0	
1R8	540 0837 000	RES 250.0 OHM 275W 10%	1.0	
1R9	542 0167 000	RES 10.0 OHM 25W	1.0	
1R10,1R11,1R12 1R13,1R14	914 3424 005	METER MULTIPLIER	5.0	
1R15	540 0635 000	RES 10.0K OHM 2W 5%	1.0	
1R16	548 0329 000	RES 10K OHM 1/2W 1%	1.0	
1R17	542 1551 000	RES 10.0 OHM 185W	1.0	
1R18	540 0637 000	RES 12.0K OHM 2W 5%	1.0	
1R19	540 0356 000	RES 10.0K OHM 1W 5%	1.0	
1R20	540 0837 000	RES 250.0 OHM 275W 10%	1.0	
1R21,1R22	540 0049 000	RES 1.0K OHM 1/2W 5%	2.0	
1S1	604 0397 000	SW, PRESS.	1.0	
1S2	604 0196 000	SW, INTLK SPDT DOOR	1.0	
1S3,1S4	604 0798 000	SW, SPDT CHEAT INTLK	2.0	
1S6	604 0061 000	SW, SPDT	1.0	
1S5A,1S5B	590 0037 000	SOLENOID 240V 60HZ	2.0	
1TB1	614 0681 000	TERM BOARD BTH6	1.0	
1TB2	614 0067 000	TERM BOARD 23 TERM	1.0	
1TB3	614 0071 000	TERM BOARD 4 TERM	1.0	
1TB4	614 0054 000	TERM BOARD 10 TERM	1.0	
1T1	916 5176 001	TOROID ASSY	1.0	
1T2	472 1042 000	XFMR FILAMENT	1.0	
1T3	472 1039 000	XFMR, FILAMENT	1.0	
1T4	472 0946 000	XFMR POWER	1.0	
1T5	472 0209 000	XFMR ISOLATION	1.0	
1XDS1,1XDS2	406 0009 000	SOCKET PILOT LIGHT	2.0	
1XV1	404 0177 000	SOCKET Y383	1.0	
	358 0185 000	RCPTCL 85 SPRING	6.0	
	402 0001 000	FUSE CLIP 31 TO 60A	6.0	
#1C18,#1C18A	402 0004 000	FUSE CLIP 0 TO 30A	2.0	
#1B1	424 0497 000	V-BELT A36	1.0	
	432 0195 000	BLOWER A10-4ACE	1.0	
	433 0069 000	BOOT, BLOWER	1.0	
	438 0089 000	BUSHING, SDS	1.0	
#1B1	438 0090 000	BUSHING, SH	1.0	
	438 0091 000	SHEAVE, COMBINATION	1.0	
#1B1	438 0092 000	SHEAVE, COMBINATION	1.0	
	452 0026 000	GEAR MITER 16 TEETH	4.0	
#1Z1	540 0833 000	RES 100.0 OHM 100W 10%	1.0	
	648 0064 000	COUNTER 815 5482 004	2.0	
	650 0138 000	KNOB, ROUND DIAL SKIRTED	1.0	

Table 7-3. MW5B (BASIC) XMTR - 994 8622 002 (Continued)

REF. SYMBOL	HARRIS PART NO.	DESCRIPTION	QTY	UM
#1C14, #1L13	650 0147 000	KNOB, CRANK	2.0	
	815 4279 001	FILTER, AIR	1.0	
	829 1869 001	WINDOW	1.0	
#1Z1	916 8224 001	COIL ASSEMBLY	1.0	
	928 7002 002	CABLE ASS'Y. MAIN	1.0	
	992 6396 001	PWB, HV PROTECTION MW5/10	1	

Table 7-4. PDM-CHASSIS-1A1 - 992 5948 001

REF. SYMBOL	HARRIS PART NO.	DESCRIPTION	QTY	UM
A1	992 3813 001	PDM PC BOARD	1.0	
A2	992 5934 001	PC BD XFMRLESS AND INPUT	1.0	
A3	992 3815 001	AUDIO DRIVER	1.0	
A4	992 4474 001	PC ASSY ME1	1.0	
A4DS1	384 0610 000	LED, GREEN	1.0	
A4DS2,A4DS3	384 0611 000	LED, RED	2.0	
A4T1	472 0730 000	XFMR, CTL P8395	1.0	
CR1	386 0101 000	ZENER 1N2992A 39V	1.0	
C1,C2	516 0067 000	CAP DISC .003UF 1KV 20%	2.0	
C003	516 0082 000	CAP, DISC .01UF 1KV GMV	1.0	
C004	500 1194 000	CAP 7500PF 500V 5%	1.0	
C005,C006,C007 C008,C009	516 0082 000	CAP, DISC .01UF 1KV GMV	5.0	
C10	508 0497 000	CAP .47UF 600V	1.0	
C11	516 0067 000	CAP DISC .003UF 1KV 20%	1.0	
C12	522 0382 000	CAP 150UF 50V	1.0	
F1	398 0054 000	FUSE SLOW CART 1A 250V	1.0	
L1	476 0383 000	CHOKE 8 HY C1722	1.0	
R2	550 0362 000	POT,MOTORIZED, DUAL	1.0	
R3	552 0250 000	POT 2000 OHM 4W	1.0	
R4	542 0084 000	RES 3.0K OHM 10W	1.0	
R5	542 0298 000	RES 2.0K OHM 100W	1.0	
R6	542 0191 000	RES 10.0K OHM 25W	1.0	
R7	542 0103 000	RES 20.0K OHM 10W	1.0	
S1	604 0196 000	SW, INTLK SPDT DOOR	1.0	
S2	604 0471 000	SW, TGL 4PDT	1.0	
TB1	614 0090 000	TERM BOARD 23 TERM	1.0	
XF1	402 0024 000	FUSE HOLDER	1.0	
	650 0021 000	KNOB RD SKIRT .911	1.0	
	929 2033 003	CABLE ASSY, PDM	1.0	

Table 7-5. PDM PC BOARD - 992 3813 001

REF. SYMBOL	HARRIS PART NO.	DESCRIPTION	QTY	UM
CR1,CR2,CR3	384 0134 000	DIODE, SILICON 1N914	3.0	
CR4	386 0092 000	ZENER 1N4744 15V	1.0	
CR5	386 0383 000	ZENER LVA43A 4.3V	1.0	
CR6	384 0134 000	DIODE, SILICON 1N914	1.0	
C1,C2,C3	500 0882 000	CAP 3600PF 500V 5%	3.0	
C4	516 0393 000	CAP DISC .025UF 500V	1.0	
C6	516 0082 000	CAP, DISC .01UF 1KV GMV	1.0	
C7	516 0393 000	CAP DISC .025UF 500V	1.0	
C8	500 0783 000	CAP 5100 PF 500V 5%	1.0	
C9	516 0054 000	CAP, DISC .001UF 1KV 10%	1.0	
C10	526 0057 000	CAP 100UF 20V 20%	1.0	
C11	526 0020 000	CAP 15UF 20V 10PCT	1.0	
C12	516 0054 000	CAP, DISC .001UF 1KV 10%	1.0	
C13	500 0837 000	CAP, MICA 510PF 500V 5%	1.0	
C14	516 0082 000	CAP, DISC .01UF 1KV GMV	1.0	
DS1	384 0568 000	DIODE, LED	1.0	
L1	492 0344 000	INDTOR VAR VIV-1500	1.0	
L2	494 0190 000	CHOKE, RF 3300 UH 80 MA	1.0	
Q1,Q2	380 0082 000	TRANSISTOR 2N1893	2.0	
Q3,Q4	380 0083 000	TRANSISTOR 2N2369	2.0	
Q5	380 0204 000	TRANSISTOR D44C9	1.0	
RT1	559 0010 000	THERMISTOR 1K OHM	1.0	
R1	540 0075 000	RES 12.0K OHM 1/2W 5%	1.0	
R2	540 0071 000	RES 8.2K OHM 1/2W 5%	1.0	
R3	540 0053 000	RES 1.5K OHM 1/2W 5%	1.0	
R4	540 0047 000	RES 820.0 OHM 1/2W 5%	1.0	
R5	540 0049 000	RES 1.0K OHM 1/2W 5%	1.0	
R6	540 0059 000	RES 2.7K OHM 1/2W 5%	1.0	
R7	540 0068 000	RES 6.2K OHM 1/2W 5%	1.0	
R8	540 0017 000	RES 47.0 OHM 1/2W 5%	1.0	
R9	540 0066 000	RES 5.1K OHM 1/2W 5%	1.0	
R10	540 0053 000	RES 1.5K OHM 1/2W 5%	1.0	
R11	540 0040 000	RES 430.0 OHM 1/2W 5%	1.0	
R12	540 0025 000	RES 100.0 OHM 1/2W 5%	1.0	
R13	540 0050 000	RES 1.1K OHM 1/2W 5%	1.0	
R14	540 0059 000	RES 2.7K OHM 1/2W 5%	1.0	
R15	540 0613 000	RES 1.2K OHM 2W 5%	1.0	
R16	540 0001 000	RES 10.0 OHM 1/2W 5%	1.0	
R17	540 0073 000	RES 10.0K OHM 1/2W 5%	1.0	
R18	540 0001 000	RES 10.0 OHM 1/2W 5%	1.0	
R19	540 0611 000	RES 1.0K OHM 2W 5%	1.0	
R20	540 0608 000	RES 750.0 OHM 2W 5%	1.0	
R21,R22	540 0049 000	RES 1.0K OHM 1/2W 5%	2.0	
R23	540 0001 000	RES 10.0 OHM 1/2W 5%	1.0	
R24,R25,R26,R27	540 0606 000	RES 620.0 OHM 2W 5%	4.0	
R28	540 0618 000	RES 2.0K OHM 2W 5%	1.0	
	938 9389 001	BOARD ASSY.	1.0	

**WARNING:** Disconnect primary power prior to servicing.

Table 7-6. PC BD XFMRLESS AND INPUT - 992 5934 001

REF. SYMBOL	HARRIS PART NO.	DESCRIPTION	QTY	UM
CR1	384 0663 000	DIODE BRIDGE VM28	1.0	
CR2,CR3,CR4	384 0205 000	DIODE SILICON 1N914	3.0	
CR5,CR6	384 0020 000	RECTIFIER IN4005	2.0	
CR7,CR8	384 0205 000	DIODE SILICON 1N914	2.0	
CR9	386 0106 000	ZENER 1N4737 7.5V	1.0	
CR10,CR11	386 0082 000	ZENER 1N4744A 15V	2.0	
CR12,CR13	384 0205 000	DIODE SILICON 1N914	2.0	
CR14,CR15	384 0663 000	DIODE BRIDGE VM28	2.0	
CR16	384 0205 000	DIODE SILICON 1N914	1.0	
C1,C2,C3,C4	516 0074 000	CAP, DISC .005UF 1KV 20%	4.0	
C5,C6,C7,C8,C9	500 0759 000	CAP, MICA 100PF 500V 5%		6.0
C10				6.0
C11,C12	516 0453 000	CAP .1UF 100V 20%	2.0	
C13	500 0759 000	CAP, MICA 100PF 500V 5%	1.0	
C14	500 0832 000	CAP, MICA 360PF 500V 5%	1.0	
C15	500 0838 000	CAP, MICA 560PF 300V 5%	1.0	
C16	500 0759 000	CAP, MICA 100PF 500V 5%	1.0	
C17	500 0827 000	CAP, MICA 130PF 500V 5%	1.0	
C18,C19,C20,C21	516 0453 000	CAP .1UF 100V 20%	4.0	
C22	522 0524 000	CAP 10 UF 25V 20%	1.0	
C23	526 0102 000	CAP 150UF 6V 20%	1.0	
C24	516 0082 000	CAP, DISC .01UF 1KV GMV	1.0	
C25	522 0524 000	CAP 10 UF 25V 20%	1.0	
C26,C27	526 0097 000	CAP 47 UF 35V 20%	2.0	
C28,C29	526 0109 000	CAP 22UF 20V 20%	2.0	
C30	500 0834 000	CAP, MICA 430PF 500V 5%	1.0	
C31	522 0524 000	CAP 10 UF 25V 20%	1.0	
C32,C33	522 0232 000	CAP 1 UF 25V	2.0	
C34	516 0082 000	CAP, DISC .01UF 1KV GMV	1.0	
C35	522 0255 000	CAP 15 UF 50V	1.0	
C36	526 0108 000	CAP 4.7UF 35V 20%	1.0	
C37,C38	522 0524 000	CAP 10 UF 25V 20%	2.0	
C39	500 0840 000	CAP, MICA 680PF 300V 5%	1.0	
C40	526 0109 000	CAP 22UF 20V 20%	1.0	
C41	508 0258 000	CAP .001 UF 600V 10%	1.0	
C42	508 0271 000	CAP .022UF 200V 10%	1.0	
C43,C44	508 0424 000	CAP .15 UF 50V 5%	2.0	
C45	522 0523 000	CAP 470UF 16V	1.0	
K1	572 0127 000	RELAY 4PDT 24VDC	1.0	
L1,L2	494 0419 000	CHOKE RF 1000.0UH	2.0	
L3,L4	494 0199 000	CHOKE RF 2200UH 10%	2.0	
P1	610 0679 000	PLUG, SHORTING	1.0	
Q1,Q2,Q3	380 0125 000	TRANSISTOR 2N4401	3.0	
Q4	380 0126 000	TRANSISTOR 2N4403	1.0	
R1,R2,R3,R4	540 0889 000	RES 110.0 OHM 1/4W 5%	4.0	
R5,R6	540 0908 000	RES 680.0 OHM 1/4W 5%	2.0	
R7,R8	540 0984 000	RES 1.0M OHM 1/4W 5%	2.0	
R9,R10	540 0936 000	RES 10.0K OHM 1/4W 5%	2.0	
R11	550 0958 000	POT 10K OHM 1/2 W 10%	1.0	

Table 7-6. PC BD XFMRLESS AND INPUT - 992 5934 001 (Continued)

REF. SYMBOL	HARRIS PART NO.	DESCRIPTION	QTY	UM
R12	540 0912 000	RES 1.0K OHM 1/4W 5%	1.0	
R13,R14,R15,R16	540 0936 000	RES 10.0K OHM 1/4W 5%	4.0	
R17	540 0935 000	RES 9.1K OHM 1/4W 5%	1.0	
R18	540 0936 000	RES 10.0K OHM 1/4W 5%	1.0	
R19	540 1334 000	RES NETWORK 15K OHM	1.0	
R20	540 0935 000	RES 9.1K OHM 1/4W 5%	1.0	
R21	540 0904 000	RES 470.0 OHM 1/4W 5%	1.0	
R22	540 0923 000	RES 3.0K OHM 1/4W 5%	1.0	
R23	540 0922 000	RES 2.7K OHM 1/4W 5%	1.0	
R24	540 0950 000	RES 39.0K OHM 1/4W 5%	1.0	
R25	540 0929 000	RES 5.1K OHM 1/4W 5%	1.0	
R26	540 0952 000	RES 47.0K OHM 1/4W 5%	1.0	
R27	540 0880 000	RES 47.0 OHM 1/4W 5%	1.0	
R28	540 0977 000	RES 510.0K OHM 1/4W 5%	1.0	
R29	550 0958 000	POT 10K OHM 1/2 W 10%	1.0	
R30	540 0936 000	RES 10.0K OHM 1/4W 5%	1.0	
R31	540 0872 000	RES 22.0 OHM 1/4W 5%	1.0	
R32	540 0922 000	RES 2.7K OHM 1/4W 5%	1.0	
R33	540 0929 000	RES 5.1K OHM 1/4W 5%	1.0	
R34	540 0872 000	RES 22.0 OHM 1/4W 5%	1.0	
R35	550 0623 000	POT, 5K OHM .5W 10%	1.0	
R36	540 0905 000	RES 510.0 OHM 1/4W 5%	1.0	
R37	540 0912 000	RES 1.0K OHM 1/4W 5%	1.0	
R38	550 0626 000	POT, 10K OHM .5W 10%	1.0	
R39	540 0904 000	RES 470.0 OHM 1/4W 5%	1.0	
R40	540 0936 000	RES 10.0K OHM 1/4W 5%	1.0	
R41,R42	550 0958 000	POT 10K OHM 1/2 W 10%	2.0	
R43	540 0587 000	RES 100.0 OHM 2W 5%	1.0	
R44	540 0912 000	RES 1.0K OHM 1/4W 5%	1.0	
R45	540 0916 000	RES 1.5K OHM 1/4W 5%	1.0	
R46	540 0587 000	RES 100.0 OHM 2W 5%	1.0	
R47	540 0916 000	RES 1.5K OHM 1/4W 5%	1.0	
R48	540 0912 000	RES 1.0K OHM 1/4W 5%	1.0	
R49	540 0943 000	RES 20.0K OHM 1/4W 5%	1.0	
R50	540 0628 000	RES 5.1K OHM 2W 5%	1.0	
R51	540 0878 000	RES 39.0 OHM 1/4W 5%	1.0	
R52,R53	550 0961 000	POT 50K OHM 1/2W 10%	2.0	
R54	540 0932 000	RES 6.8K OHM 1/4W 5%	1.0	
R55	540 0942 000	RES 18.0K OHM 1/4W 5%	1.0	
R56	540 0949 000	RES 36.0K OHM 1/4W 5%	1.0	
R57	540 0966 000	RES 180.0K OHM 1/4W 5%	1.0	
R58	540 0912 000	RES 1.0K OHM 1/4W 5%	1.0	
R59,R60	540 0936 000	RES 10.0K OHM 1/4W 5%	2.0	
R61	540 0928 000	RES 4.7K OHM 1/4W 5%	1.0	
R62	540 0930 000	RES 5.6K OHM 1/4W 5%	1.0	
R63	540 0912 000	RES 1.0K OHM 1/4W 5%	1.0	
R64	540 0899 000	RES 300.0 OHM 1/4W 5%	1.0	
R65	540 0927 000	RES 4.3K OHM 1/4W 5%	1.0	
R66	550 0956 000	POT 2000 OHM 1/2W 10%	1.0	

WARNING: Disconnect primary power prior to servicing.



Table 7-6. PC BD XFMRLESS AND INPUT - 992 5934 001 (Continued)

REF. SYMBOL	HARRIS PART NO.	DESCRIPTION	QTY	UM
S1	602 0143 000	SW, LEV DPDT DIP	1.0	
T1	472 0713 000	XFMR, POWER	1.0	
U1	382 0552 000	IC TL074CN3	1.0	
U2	382 0636 000	IC TL071CP3	1.0	
U3	382 0711 000	IC AD534-JH	1.0	
XK1	404 0214 000	RELAY SOCKET	1.0	
XR19	404 0675 000	SOCKET, IC 16 CONT	1.0	
XU3	404 0303 000	SOCKET, IC 10 PIN	1.0	
	943 3854 001	PC BD AUDIO INPUT PDM	1.0	

Table 7-7. AUDIO DRIVER - 992 3815 001

REF. SYMBOL	HARRIS PART NO.	DESCRIPTION	QTY	UM
CR1,CR2,CR3,CR4 CR5,CR6	384 0134 000	DIODE, SILICON 1N914	6.0	
CR7	386 0124 000	ZENER 1N4736A 6.8V	1.0	
CR8,CR9,CR10	386 0343 000	ZENER 1N3001A 68V	3.0	
CR11	386 0344 000	ZENER 1N2988A 27V	1.0	
CR12	384 0566 000	DIODE MR834	1.0	
CR13	384 0134 000	DIODE, SILICON 1N914	1.0	
CR14	384 0368 000	RECTIFIER 1N5054	1.0	
CR15	386 0087 000	ZENER 1N2995A 47V	1.0	
C1,C2,C3,C4,C5 C6	500 0804 000	CAP, MICA 10PF 500V 5%	6.0	
C7	516 0074 000	CAP, DISC .005UF 1KV 20%	1.0	
C8	522 0522 000	CAP 15 UF 450V	1.0	
C9	516 0087 000	CAP DISC .05UF 600V	1.0	
C10	516 0082 000	CAP, DISC .01UF 1KV GMV	1.0	
C11	522 0521 000	CAP 100UF 150V	1.0	
Q1,Q2	380 0478 000	TRANSISTOR SVT-350-3	2.0	
R1	540 0001 000	RES 10.0 OHM 1/2W 5%	1.0	
R2	540 0033 000	RES 220.0 OHM 1/2W 5%	1.0	
R3	540 0563 000	RES 10.0 OHM 2W 5%	1.0	
R4	540 0060 000	RES 3.0K OHM 1/2W 5%	1.0	
R5	540 0571 000	RES 22.0 OHM 2W 5%	1.0	
R6	540 0670 000	RES 300.0K OHM 2W 5%	1.0	
R7	540 0073 000	RES 10.0K OHM 1/2W 5%	1.0	
R8	552 0794 000	POT 20 OHM 2W	1.0	
R9	540 0032 000	RES 200.0 OHM 1/2W 5%	1.0	
R10	540 0049 000	RES 1.0K OHM 1/2W 5%	1.0	
R11	542 1052 000	RES 40.0 OHM 10W	1.0	
R12,R13	540 1166 000	RES 2.7 OHM 1/2W 5%	2.0	
R14	540 0670 000	RES 300.0K OHM 2W 5%	1.0	
R15	540 0073 000	RES 10.0K OHM 1/2W 5%	1.0	
	939 0110 001	PRINTED BOARD	1.0	

Table 7-8. PC ASSY ME1 - 992 4474 001

REF. SYMBOL	HARRIS PART NO.	DESCRIPTION	QTY	UM
CR1, CR2, CR3, CR4	384 0020 000	RECTIFIER IN4005	4.0	
CR5	386 0145 000	ZENER 1N3022A 12V	1.0	
CR6	384 0134 000	DIODE, SILICON 1N914	1.0	
CR7	386 0145 000	ZENER 1N3022A 12V	1.0	
CR8	384 0134 000	DIODE, SILICON 1N914	1.0	
C1, C2	522 0417 000	CAP 1000UF 25V	2.0	
F1	398 0011 000	FUSE FAST CART .250A 250V	1.0	
Q1	380 0126 000	TRANSISTOR 2N4403	1.0	
Q2, Q3	380 0125 000	TRANSISTOR 2N4401	2.0	
Q4	380 0126 000	TRANSISTOR 2N4403	1.0	
R1, R2	540 0018 000	RES 51.0 OHM 1/2W 5%	2.0	
R3	540 0055 000	RES 1.8K OHM 1/2W 5%	1.0	
R4, R5	540 0018 000	RES 51.0 OHM 1/2W 5%	2.0	
R6, R7	540 0025 000	RES 100.0 OHM 1/2W 5%	2.0	
R8	540 0055 000	RES 1.8K OHM 1/2W 5%	1.0	
R9, R10	540 0021 000	RES 68.0 OHM 1/2W 5%	2.0	
R11	540 0059 000	RES 2.7K OHM 1/2W 5%	1.0	
R12, R13	540 0014 000	RES 36.0 OHM 1/2W 5%	2.0	
R14	540 0066 000	RES 5.1K OHM 1/2W 5%	1.0	
R15	540 0615 000	RES 1.5K OHM 2W 5%	1.0	
R16	550 0966 000	POT 2K OHM 1/2W/.3W 10%	1.0	
R17	540 0035 000	RES 270.0 OHM 1/2W 5%	1.0	
R18	540 0332 000	RES 1.0K OHM 1W 5%	1.0	
R19	540 0083 000	RES 27.0K OHM 1/2W 5%	1.0	
R20	550 0966 000	POT 2K OHM 1/2W/.3W 10%	1.0	
R21	540 0035 000	RES 270.0 OHM 1/2W 5%	1.0	
R22	540 0332 000	RES 1.0K OHM 1W 5%	1.0	
R23	540 0083 000	RES 27.0K OHM 1/2W 5%	1.0	
S1	604 0813 000	SW, PB 4 STATIONS	1.0	
TB1	614 0696 000	TERM BOARD 5 TERM	1.0	
	939 1062 001	P.C. BOARD	1.0	
	402 0129 000	CLIP FUSE	2.0	

Table 7-9. RF AND OVERLOAD - 992 3816 002

REF. SYMBOL	HARRIS PART NO.	DESCRIPTION	QTY	UM
A1	992 3817 001	OSCILLATOR	1.0	
A3	992 3819 002	RF DRIVER, 1A2A3	1.0	
R4	552 0307 000	RHEOSTAT 10 OHM 25W	1.0	
S1	604 0196 000	SW, INTLK SPDT DOOR	1.0	
TB1	614 0090 000	TERM BOARD 23 TERM	1.0	
1A2A2	992 4962 002	FLAG/OVERLOAD PC	1.0	

Table 7-10. OSCILLATOR - 992 3817 001

REF. SYMBOL	HARRIS PART NO.	DESCRIPTION	QTY	UM
CR1	386 0082 000	ZENER 1N4744A 15V	1.0	
CR2	386 0135 000	ZENER 1N4733A 5.1V	1.0	
CR3,CR4,CR5	384 0134 000	DIODE, SILICON 1N914	3.0	
CR6	384 0020 000	RECTIFIER IN4005	1.0	
C1	520 0443 000	CAP, VAR 2.4-24.5PF	1.0	
C2	500 0805 000	CAP MICA 12UUF 500V	1.0	
C3	500 0837 000	CAP, MICA 510PF 500V 5%	1.0	
C4	516 0387 000	CAP .47 UF 10V	1.0	
C5	500 0761 000	CAP, MICA 150PF 500V 5%	1.0	
C6	516 0080 000	CAP DISC .01UF 600V	1.0	
C7	520 0443 000	CAP, VAR 2.4-24.5PF	1.0	
C8	500 0805 000	CAP MICA 12UUF 500V	1.0	
C9	500 0837 000	CAP, MICA 510PF 500V 5%	1.0	
C10	516 0387 000	CAP .47 UF 10V	1.0	
C11	500 0761 000	CAP, MICA 150PF 500V 5%	1.0	
C12	516 0080 000	CAP DISC .01UF 600V	1.0	
C13,C14,C15,C16	508 0378 000	CAP .22 UF 100V 10%	4.0	
DS1,DS2	384 0568 000	DIODE, LED	2.0	
F1	398 0017 000	FUSE FAST CART 1A 250V	1.0	
K1	574 0352 000	RELAY CORREED CC-12	1.0	
L1	494 0196 000	CHOKE RF 100UH	1.0	
L2	494 0361 000	CHOKE, 55UH, 500 MA	1.0	
Q1,Q2,Q3	380 0083 000	TRANSISTOR 2N2369	3.0	
Q4	380 0204 000	TRANSISTOR D44C9	1.0	
R1	540 0087 000	RES 39.0K OHM 1/2W 5%	1.0	
R2	540 0079 000	RES 18.0K OHM 1/2W 5%	1.0	
R3	540 0015 000	RES 39.0 OHM 1/2W 5%	1.0	
R4	540 0035 000	RES 270.0 OHM 1/2W 5%	1.0	
R5	540 0049 000	RES 1.0K OHM 1/2W 5%	1.0	
R6	540 0065 000	RES 4.7K OHM 1/2W 5%	1.0	
R7	540 0087 000	RES 39.0K OHM 1/2W 5%	1.0	
R8	540 0079 000	RES 18.0K OHM 1/2W 5%	1.0	
R9	540 0015 000	RES 39.0 OHM 1/2W 5%	1.0	
R10	540 0035 000	RES 270.0 OHM 1/2W 5%	1.0	
R11	540 0049 000	RES 1.0K OHM 1/2W 5%	1.0	
R12	540 0065 000	RES 4.7K OHM 1/2W 5%	1.0	
R13,R14,R15	540 0611 000	RES 1.0K OHM 2W 5%	3.0	
R16	540 0046 000	RES 750.0 OHM 1/2W 5%	1.0	
R17	540 0065 000	RES 4.7K OHM 1/2W 5%	1.0	
R18	540 0611 000	RES 1.0K OHM 2W 5%	1.0	
R19	540 0025 000	RES 100.0 OHM 1/2W 5%	1.0	
R21	540 1129 000	RES 1.5K OHM 1/2W 5%	1.0	
R22	540 0041 000	RES 470.0 OHM 1/2W 5%	1.0	
R23,R24	540 0577 000	RES 39.0 OHM 2W 5%	2.0	
R25	540 0051 000	RES 1.2K OHM 1/2W 5%	1.0	
R26,R27	540 0032 000	RES 200.0 OHM 1/2W 5%	2.0	
S1	604 0748 000	SW, TGL 2 POS	1.0	
U1	382 0074 000	IC 7476	1.0	
XF1,XF1A	402 0129 000	CLIP FUSE	2.0	

Table 7-10. OSCILLATOR - 992 3817 001 (Continued)

REF. SYMBOL	HARRIS PART NO.	DESCRIPTION	QTY	UM
XU1	404 0306 000	SOCKET, IC 583529-1	1.0	
XY1,XY2	404 0267 000	SOCKET CRYSTAL	2.0	
	938 9889 001	PRINTED BOARD	1.0	

Table 7-11. RF DRIVER, 1A2A3 - 992 3819 002

REF. SYMBOL	HARRIS PART NO.	DESCRIPTION	QTY	UM
A1,A2,A3,A4,A5	992 3820 001	RF DRIVER MODULE	5.0	
DS1	396 0120 000	LAMP .035A 28V 1819	1.0	
DS2,DS3,DS4,DS5	396 0046 000	LAMP .25 AMP 6 TO 8V	4.0	
F1,F2,F3,F4,F5	398 0090 000	FUSE SLOW CART 3A 32V	5.0	
L1	492 0603 000	COIL, VAR 1-2.5UH	1.0	
R1,R2	540 0044 000	RES 620.0 OHM 1/2W 5%	2.0	
R3	542 0049 000	RES 1.0 OHM 10W	1.0	
R5,R6,R7,R8	540 0583 000	RES 68.0 OHM 2W 5%	4.0	
XDS1,XDS2,XDS3	406 0317 000	SOCKET. LAMP 7-08		
XDS4,XDS5			5.0	
XF1,XF2,XF3,XF4	402 0024 000	FUSE HOLDER		
XF5			5.0	
	928 6787 001	PRINTED ASSEMBLY	1.0	
	928 7106 001	CABLE ASSEMBLY	1.0	

Table 7-12. RF DRIVER MODULE - 992 3820 001

REF. SYMBOL	HARRIS PART NO.	DESCRIPTION	QTY	UM
CR3,CR4	384 0678 000	DIODE, FAST RECOVERY	2.0	
C1	500 0883 000	CAP 4700PF 500V 5%	1.0	
C2,C3	508 0345 000	CAP .47UF 200V 10%	2.0	
Q1,Q2	380 0513 000	TRANSISTOR	2.0	
R1	540 0716 000	RES 10.0 OHM 2W 10%	1.0	



Table 7-13. FLAG/OVERLOAD PC - 992 4962 002

REF. SYMBOL	HARRIS PART NO.	DESCRIPTION	QTY	UM
CR1,CR2,CR3,CR4 CR5,CR6,CR7,CR8 CR9,CR10,CR11 CR12,CR13,CR14 CR15	384 0020 000	RECTIFIER IN4005		15.0
CR16	386 0092 000	ZENER 1N4744 15V	1.0	
CR17	384 0020 000	RECTIFIER IN4005	1.0	
CR19	386 0383 000	ZENER LVA43A 4.3V	1.0	
CR20	386 0169 000	ZENER 1N5352A 15V	1.0	
CR21	386 0345 000	ZENER 1N5342 6.8V	1.0	
CR22	384 0020 000	RECTIFIER IN4005	1.0	
C1	522 0254 000	CAP 10 UF 50V	1.0	
C2	522 0257 000	CAP 35UF 50V	1.0	
C3,C4,C5,C6,C7 C8,C9	516 0082 000	CAP, DISC .01UF 1KV GMV		7.0
C010	526 0359 000	CAP 47UF 20V 10%	1.0	
C11	526 0361 000	CAP 68 UF 60V	1.0	
C12	508 0503 000	CAP .027UF 50V 10%	1.0	
DS1	384 0568 000	DIODE, LED	1.0	
F1	398 0019 000	FUSE FAST CART 2A 250V	1.0	
K1,K2,K3,K4,K5	574 0351 000	RLY LATCHING CC-69	5.0	
K6,K7	574 0352 000	RELAY CORREED CC-12	2.0	
Q1,Q2	380 0179 000	TRANSISTOR MPS-U45	2.0	
R1,R2	540 0611 000	RES 1.0K OHM 2W 5%	2.0	
R3	540 0025 000	RES 100.0 OHM 1/2W 5%	1.0	
R4	540 0606 000	RES 620.0 OHM 2W 5%	1.0	
R5	540 0053 000	RES 1.5K OHM 1/2W 5%	1.0	
R6	540 0089 000	RES 47.0K OHM 1/2W 5%	1.0	
R7	540 0025 000	RES 100.0 OHM 1/2W 5%	1.0	
R8	540 0121 000	RES 1.0M OHM 1/2W 5%	1.0	
R9	540 0073 000	RES 10.0K OHM 1/2W 5%	1.0	
R10	540 0121 000	RES 1.0M OHM 1/2W 5%	1.0	
R11	540 0017 000	RES 47.0 OHM 1/2W 5%	1.0	
R12,R13,R14,R15	540 0611 000	RES 1.0K OHM 2W 5%	4.0	
R16	540 0073 000	RES 10.0K OHM 1/2W 5%	1.0	
R17,R18,R19	540 0065 000	RES 4.7K OHM 1/2W 5%	3.0	
R20,R21	540 0073 000	RES 10.0K OHM 1/2W 5%	2.0	
R22	540 0089 000	RES 47.0K OHM 1/2W 5%	1.0	
R23,R24	550 0351 000	POT, TRIMMER 10K OHM	2.0	
R25	540 0912 000	RES 1.0K OHM 1/4W 5%	1.0	
R26	550 0806 000	POT., 500K OHM, 1/4W	1.0	
R27	540 0960 000	RES 100.0K OHM 1/4W 5%	1.0	
R28	540 0936 000	RES 10.0K OHM 1/4W 5%	1.0	
R29,R30	540 0984 000	RES 1.0M OHM 1/4W 5%	2.0	
R31	540 0940 000	RES 15.0K OHM 1/4W 5%	1.0	
R32	550 0367 000	POT 50K OHM 1/4W 20%	1.0	
R33	540 1008 000	RES 10.0M OHM 1/4W 5%	1.0	
R34	540 0073 000	RES 10.0K OHM 1/2W 5%	1.0	
R35	540 0611 000	RES 1.0K OHM 2W 5%	1.0	

Table 7-13. FLAG/OVERLOAD PC - 992 4962 002 (Continued)

REF. SYMBOL	HARRIS PART NO.	DESCRIPTION	QTY	UM
R36	540 0608 000	RES 750.0 OHM 2W 5%	1.0	
R37	540 0622 000	RES 3.0K OHM 2W 5%	1.0	
R38,R39	540 0912 000	RES 1.0K OHM 1/4W 5%	2.0	
R40	540 0090 000	RES 51.0K OHM 1/2W 5%	1.0	
S1	604 0748 000	SW, TGL 2 POS	1.0	
U1	382 0415 000	IC 324	1.0	
XF1A,XF1B	402 0129 000	CLIP FUSE	2.0	
XU1	404 0305 000	SOCKET, IC 583527-1	1.0	
	929 7127 001	PC BD ASSY	1.0	

Table 7-14. PA GRID, ISO PLATE - 992 3821 002

REF. SYMBOL	HARRIS PART NO.	DESCRIPTION	QTY	UM
C1	514 0145 000	CAP VAR 25-500PF	1.0	
C1	530 0002 000	FLG MTG TERM FMOB	1.0	
C1	530 0005 000	FLG MTG TERMINAL FM2	1.0	
C3	514 0330 000	CAP VAR 10-50PF 30KV	1.0	
C4	516 0206 000	CAP HV 1000 UUF 5000	1.0	
C5,C6	516 0509 000	CAP 2.2UF 50V 20%	2.0	
C7,C8	500 0657 000	CAP .03UF 600VDC 10%	2.0	
C9	516 0209 000	CAP HV 100 UUF 15KV	1.0	
L1	928 6796 001	COIL ASSEMBLY	1.0	
L2	494 0098 000	CHOKER R.F. 1 MHY	1.0	
M1	632 0888 000	METER, 0-300 MADC	1.0	
M2	632 1007 000	METER 0-1.5ADC	1.0	
R1,R2,R3	542 0303 000	RES 10.0K OHM 100W	3.0	
	929 0135 001	CAPACITOR, MOD	1.0	

Table 7-15. AC POWER PANEL, 1A4 - 992 3822 002

REF. SYMBOL	HARRIS PART NO.	DESCRIPTION	QTY	UM
A1	992 4961 001	RELAY OVERLOAD BD	1.0	
CB1, CB2, CB3	606 0521 000	BREAKER, CKT 15 AMP	3.0	
CB4	606 0465 000	BREAKER, CKT 3 AMPS	1.0	
CB5	606 0475 000	BREAKER, CKT 5A	1.0	
CB6	606 0465 000	BREAKER, CKT 3 AMPS	1.0	
CB7	606 0466 000	BREAKER, CKT 0.1 AMP	1.0	
CB8, CB9	606 0467 000	BREAKER, CKT 2 AMPS	2.0	
K1	570 0120 000	CONTACTOR 40 AMP	1.0	
K2	574 0062 000	RELAY LATCHING 4 PDT	1.0	
K3	570 0120 000	CONTACTOR 40 AMP	1.0	
K4	570 0224 000	CONTACTOR 40 AMP	1.0	
K5	574 0062 000	RELAY LATCHING 4 PDT	1.0	
K6	570 0120 000	CONTACTOR 40 AMP	1.0	
M1	636 0035 000	METER 115V 60HZ	1.0	
R1, R2, R3	542 0083 000	RES 2.5K OHM 10W	3.0	
R4	552 0430 000	RHEOSTAT 10 OHM 225W	1.0	
R5	552 0386 000	RHEO, 200 OHM 100W	1.0	
R6, R7, R8	542 1010 000	RES 5.5 OHM 155W	3.0	
R9	552 0769 000	RHEO 350 OHM 12.5W	1.0	
R10	552 0385 000	RHEO, 100 OHM 100W	1.0	
R12	542 0083 000	RES 2.5K OHM 10W	1.0	
S1	915 2583 006	MOD. MON. SELETOR SW.	1.0	
	650 0021 000	KNOB RD SKIRT .911	1.0	
	650 0148 000	KNOB ROUND 225 3 5G	1.0	

Table 7-16. RELAY OVERLOAD BD - 992 4961 001

REF. SYMBOL	HARRIS PART NO.	DESCRIPTION	QTY	UM
CR1	386 0375 000	ZENER 1N5335 3.9V	1.0	
CR2,CR3	384 0020 000	RECTIFIER IN4005	2.0	
C1	522 0372 000	CAP 2500 UF 15V	1.0	
C2	522 0392 000	CAP 400UF 50 VDC	1.0	
K1,K2	574 0225 000	RELAY 6VDC 4PDT	2.0	
K3,K4	572 0127 000	RELAY 4PDT 24VDC	2.0	
R1	540 0571 000	RES 22.0 OHM 2W 5%	1.0	
R2	540 0587 000	RES 100.0 OHM 2W 5%	1.0	
R3	540 0045 000	RES 680.0 OHM 1/2W 5%	1.0	
TD1	576 0121 000	RELAY, DELAY 26N05T	1.0	
XK1,XK2,XK3,XK4	404 0214 000	RELAY SOCKET	4.0	
XTD1	404 0059 000	SOCKET TUBE 9 PIN	1.0	
	939 2803 001	PC BOARD	1.0	

Table 7-17. POWER SUPPLY, 1A5 - 992 4032 002

REF. SYMBOL	HARRIS PART NO.	DESCRIPTION	QTY	UM
CR1,CR2,CR3,CR4	384 0315 000	RECT SILICON 40HF60	4.0	
CR5,CR6,CR7,CR8	384 0020 000	RECTIFIER IN4005	4.0	
C1,C2,C3,C4	524 0313 000	CAP 25,000UF 40VDC	4.0	
C5	522 0133 000	CAP 16 UF 450V	1.0	
L1	476 0384 000	CHOKE 1 HY 350MADC	1.0	
R1,R2,R3,R4	542 0060 000	RES 100.0 OHM 10W	4.0	
R5,R6	540 0060 000	RES 3.0K OHM 1/2W 5%	2.0	
R7,R8	542 0282 000	RES 1.0 OHM 100W	2.0	
R9	540 0659 000	RES 100.0K OHM 2W 5%	1.0	
R10	542 0170 000	RES 50.0 OHM 25W	1.0	
TB1	614 0053 000	TERM BOARD 9 TERM	1.0	
T1	472 0992 000	XFMR, LOW VOLTAGE	1.0	
T2	472 0954 000	XFMR, BIAS	1.0	
	929 1857 001	CABLE ASSY	1.0	

Table 7-18. LEFT METER PANEL 1A7 - 992 3825 002

REF. SYMBOL	HARRIS PART NO.	DESCRIPTION	QTY	UM
CR1	384 0134 000	DIODE, SILICON 1N914	1.0	
C1,C2,C4,C5	516 0082 000	CAP, DISC .01UF 1KV GMV	4.0	
DS2,DS3,DS4,DS5	396 0060 000	LAMP .04 AMP 28V 327	4.0	
M1	632 0777 000	METER 0-12/0-30 SCL	1.0	
M2	632 0775 000	METER 0-1.5ADC SCALE	1.0	
R1	550 0059 000	POT, 500 OHM 2W	1.0	
R2	540 0049 000	RES 1.0K OHM 1/2W 5%	1.0	
R3	540 0057 000	RES 2.2K OHM 1/2W 5%	1.0	
R4	550 0066 000	POT 7.5K OHM 2W	1.0	
R5	540 0065 000	RES 4.7K OHM 1/2W 5%	1.0	
R6	540 0099 000	RES 120.0K OHM 1/2W 5%	1.0	
R7	540 0186 000	RES 4.7K OHM 1/2W 5%	1.0	
R8	550 0065 000	POT 5K OHM 2W 10%	1.0	
S1,S2,S3,S4,S5	604 0445 000	SW, PB LESS LENS CAP		
S6			6.0	
	500 0783 000	CAP 5100 PF 500V 5%	1.0	
	598 0118 000	LENS CAP SW GREEN	2.0	
	598 0119 000	LENS CAP, SW, RED	2.0	
	598 0189 000	LENS CAP, YELLOW	1.0	
	598 0194 000	LENS CAP, BLUE	1.0	
	650 0028 000	KNOB RD SKIRT 1.135	1.0	
	914 9494 006	MOD SW CTL	1.0	

Table 7-19. DIRECTIONAL COUPLER - 992 3826 001

REF. SYMBOL	HARRIS PART NO.	DESCRIPTION	QTY	UM
CR1,CR2	384 0205 000	DIODE SILICON 1N914	2.0	
C1,C2	500 0837 000	CAP, MICA 510PF 500V 5%	2.0	
C3	520 0119 000	CAP VAR 6.7-140PF	1.0	
C4	500 0826 000	CAP, MICA 120PF 500V 5%	1.0	
C6,C7	500 0807 000	CAP MICA 18UUF 500V	2.0	
C8	500 0826 000	CAP, MICA 120PF 500V 5%	1.0	
C9	520 0119 000	CAP VAR 6.7-140PF	1.0	
C11,C12	500 0837 000	CAP, MICA 510PF 500V 5%	2.0	
R1	540 0089 000	RES 47.0K OHM 1/2W 5%	1.0	
R2	550 0073 000	POT, 100K OHM 2W	1.0	
R3	540 0089 000	RES 47.0K OHM 1/2W 5%	1.0	
R4,R5	540 0587 000	RES 100.0 OHM 2W 5%	2.0	
R6	540 0089 000	RES 47.0K OHM 1/2W 5%	1.0	
R7	550 0073 000	POT, 100K OHM 2W	1.0	
R8	540 0089 000	RES 47.0K OHM 1/2W 5%	1.0	
R9	540 0092 000	RES 62.0K OHM 1/2W 5%	1.0	
T1	914 6686 001	TRANSFORMER	1.0	

**WARNING:** Disconnect primary power prior to servicing.



Table 7-20. RT MRT PANEL - 992 3827 001

REF. SYMBOL	HARRIS PART NO.	DESCRIPTION	QTY	UM
C1,C2	516 0082 000	CAP, DISC .01UF 1KV GMV	2.0	
DS1,DS2,DS3,DS4	384 0730 000	LED, RED, 5082-4855		
DS5			5.0	
M1	632 0774 000	METER 0-6KVDC SCALE	1.0	
M2	632 0778 000	METER 0-10KW SCALE	1.0	
R1	550 0061 000	POT, 1K OHM 2W	1.0	
R2	548 0181 000	RES 6190 OHM .5W 1%	1.0	
R3	548 1204 000	RES 22.6K OHM 1/4W 1%	1.0	
R4	550 0061 000	POT, 1K OHM 2W	1.0	
S1	604 0405 000	SW, PB BLK SPDT	1.0	
S2	914 9494 007	MOD SW CTL	1.0	
	650 0028 000	KNOB RD SKIRT 1.135	1.0	
	815 3002 002	GLASS	1.0	
	928 6897 001	BOARD, LED MTG.	1.0	

Table 7-21. HV RECTIFIER - 992 4036 001

REF. SYMBOL	HARRIS PART NO.	DESCRIPTION	QTY	UM
CR1,CR2,CR3,CR4 CR5,CR6,CR7,CR8 CR9,CR10,CR11 CR12	384 0582 000	RECT, SILICON EFT-15H20		
	828 6040 001	BOARD, MOUNTING	12.0	
	852 7591 002	SCHEMATIC	1.0	
			0	

**WARNING:** Disconnect primary power prior to servicing.

Table 7-22. MOD SCR PS/MOD MON - 992 4033 001

REF. SYMBOL	HARRIS PART NO.	DESCRIPTION	QTY	UM
CR1	384 0764 000	RECT., BRIDGE 15A 600	1.0	
C1	524 0139 000	CAP 330 UF 450V	1.0	
C2	522 0372 000	CAP 2500 UF 15V	1.0	
J1	620 0410 000	JACK, BULKHEAD UG-657/U	1.0	
K1	574 0040 000	RELAY DPDT 115VAC	1.0	
R1	542 0167 000	RES 10.0 OHM 25W	1.0	
R2	540 0075 000	RES 12.0K OHM 1/2W 5%	1.0	
R3	552 0085 000	RES ADJ 50 OHM 50W	1.0	
R4	542 0105 000	RES 25.0K OHM 12W	1.0	
TB1	614 0050 000	TERM BOARD 6 TERM	1.0	
T1	472 0993 000	XFMR, SCREEN	1.0	

Table 7-23. METER MULTIPLIER - 938 4433 004

REF. SYMBOL	HARRIS PART NO.	DESCRIPTION	QTY	UM
R1,R2,R3,R4,R5 R6,R7,R8,R9,R10 R11,R12,R13,R14 R15,R16,R17,R18 R19,R20	548 0373 000	RES 249K OHM 1/2W 1%	20.0	

Table 7-24. PWB, HV PROTECTION MW5/10 - 992 6396 001

REF. SYMBOL	HARRIS PART NO.	DESCRIPTION	QTY	UM
CR001	384 0663 000	DIODE BRIDGE VM28	1.0	
CR002,CR003	386 0366 000	ZENER 1N5359A 24V	2.0	
CR004	384 0205 000	DIODE SILICON 1N914	1.0	
CR005,CR006	384 0597 000	RECT 1N4002		
CR007,CR008			4.0	
CR009,CR010	384 0431 000	RECT. 1N4001		
CR011,CR012				
CR013,CR014			6.0	
C001	516 0793 000	CAP 470PF 15KVDC	1.0	
C002	516 0411 000	CAP .1UF 50V DISC	1.0	
C003,C004	522 0394 000	CAP 100UF 50V	2.0	
C005,C006	526 0238 000	CAP 33UF 35V 20%	2.0	
C007	516 0085 000	CAP DISC .03UF 600V	1.0	
C008	500 0759 000	CAP, MICA 100PF 500V 5%	1.0	
C009	516 0453 000	CAP .1UF 100V 20%	1.0	
C010	500 0844 000	CAP, MICA 1000PF 100V 5%	1.0	
C011	516 0453 000	CAP .1UF 100V 20%	1.0	
C012,C013,C014	508 0543 000	CAP .1UF 160V 1%		
C015,C016,C017			6.0	
C018	506 0233 000	CAP .1UF 63V 5%	1.0	
C019,C020	516 0453 000	CAP .1UF 100V 20%	2.0	
C021	500 0759 000	CAP, MICA 100PF 500V 5%	1.0	
C022	516 0453 000	CAP .1UF 100V 20%	1.0	
C023	506 0234 000	CAP .0022UF 63V 5%	1.0	
C024	516 0453 000	CAP .1UF 100V 20%	1.0	
C025	526 0049 000	CAP 6.8UF 35V 20%	1.0	
C026,C027	516 0453 000	CAP .1UF 100V 20%	2.0	
C028	526 0097 000	CAP 47 UF 35V 20%	1.0	
C029	516 0054 000	CAP, DISC .001UF 1KV 10%	1.0	
C030	500 0844 000	CAP, MICA 1000PF 100V 5%	1.0	
C031,C032	526 0351 000	CAP 6.8UF 50V 20%	2.0	
C033,C034,C035	516 0453 000	CAP .1UF 100V 20%		
C036,C037,C038			6.0	
DS1	384 0662 000	L.E.D. RED	1.0	
E1	913 3562 001	CARBON BLOCK HOLDER	1.0	
F001	398 0006 000	FUSE FAST CART .125A 250V	1.0	
Q001,Q002	380 0125 000	TRANSISTOR 2N4401	2.0	
R01,R02	540 0912 000	RES 1.0K OHM 1/4W 5%	2.0	
R3,R4	542 0018 000	RES 200.0 OHM 5W	2.0	
R005	540 0967 000	RES 200.0K OHM 1/4W 5%	1.0	
R006	540 0955 000	RES 62.0K OHM 1/4W 5%	1.0	
R7	550 0954 000	POT 100K .5W MULTITURN	1.0	
R008	548 1431 000	RES 78.7K OHM 1/4W 1%	1.0	
R009	548 0997 000	RES 20K OHM 1/4W 1%	1.0	
R010	548 1398 000	RES 11.5K OHM 1/4W 1%	1.0	
R011,R012	548 1395 000	RES 43.2K OHM 1/4W 1%	2.0	
R013	548 1431 000	RES 78.7K OHM 1/4W 1%	1.0	
R014	548 1455 000	RES 28K OHM 1/4W 1%	1.0	
R015	548 1362 000	RES 13.3K OHM 1/4W 1%	1.0	

Table 7-24. PWB, HV PROTECTION MW5/10 - 992 6396 001 (Continued)

REF. SYMBOL	HARRIS PART NO.	DESCRIPTION	QTY	UM
R016,R017	548 0866 000	RES 56.2K OHM 1/4W 1%	2.0	
R018	548 1431 000	RES 78.7K OHM 1/4W 1%	1.0	
R019	548 1400 000	RES 17.8K OHM 1/4W 1%	1.0	
R020	548 0414 000	RES 8870 OHM 1/4W 1%	1.0	
R021,R022	548 1451 000	RES 36.5K OHM 1/4W 1%	2.0	
R023	540 0973 000	RES 360.0K OHM 1/4W 5%	1.0	
R24	540 0912 000	RES 1.0K OHM 1/4W 5%	1.0	
R25	540 0936 000	RES 10.0K OHM 1/4W 5%	1.0	
R027	540 0920 000	RES 2.2K OHM 1/4W 5%	1.0	
R028	540 0938 000	RES 12.0K OHM 1/4W 5%	1.0	
R029,R030	540 0921 000	RES 2.4K OHM 1/4W 5%	2.0	
R031	540 0923 000	RES 3.0K OHM 1/4W 5%	1.0	
R032	540 0948 000	RES 33.0K OHM 1/4W 5%	1.0	
R033	540 0928 000	RES 4.7K OHM 1/4W 5%	1.0	
R034	540 0886 000	RES 82.0 OHM 1/4W 5%	1.0	
R035	540 0042 000	RES 510.0 OHM 1/2W 5%	1.0	
R036	540 0952 000	RES 47.0K OHM 1/4W 5%	1.0	
R038	540 0929 000	RES 5.1K OHM 1/4W 5%	1.0	
R39,R40,R41,R42	540 0936 000	RES 10.0K OHM 1/4W 5%	4.0	
R043	540 0964 000	RES 150.0K OHM 1/4W 5%	1.0	
R044	540 0046 000	RES 750.0 OHM 1/2W 5%	1.0	
R45	540 0936 000	RES 10.0K OHM 1/4W 5%	1.0	
R046	540 0947 000	RES 30.0K OHM 1/4W 5%	1.0	
R047	540 0984 000	RES 1.0M OHM 1/4W 5%	1.0	
R048	540 0947 000	RES 30.0K OHM 1/4W 5%	1.0	
R049,R050	540 0919 000	RES 2.0K OHM 1/4W 5%	2.0	
R51	540 0936 000	RES 10.0K OHM 1/4W 5%	1.0	
R052	540 0317 000	RES 240.0 OHM 1W 5%	1.0	
R053	540 0936 000	RES 10.0K OHM 1/4W 5%	1.0	
TB1	614 0715 000	TERM BOARD 4 TERM	1.0	
TP001,TP002	610 0750 000	TEST PROBE, TYPE C		
TP003			3.0	
T001	472 1299 000	XFMR, POWER	1.0	
U001,U002	382 0552 000	IC TL074CN3	2.0	
U003	382 0452 000	IC LM311/CA311	1.0	
U004	382 0359 000	IC 7815	1.0	
U005	382 0972 000	IC 4071B	1.0	
U006	382 0366 000	IC MC14528BCP	1.0	
U007	382 0588 000	IC 4013	1.0	
U008	382 0971 000	IC 4069UB	1.0	
U009	382 0360 000	IC 7915	1.0	
U010	382 0523 000	IC MC14066BCPDS	1.0	
XU01,XU02	404 0674 000	SOCKET, IC 14 CONT	2.0	
XU03	404 0673 000	SOCKET, IC 8 CONT	1.0	
XU05	404 0674 000	SOCKET, IC 14 CONT	1.0	
XU006	404 0675 000	SOCKET, IC 16 CONT	1.0	
XU07,XU08,XU10	404 0674 000	SOCKET, IC 14 CONT	3.0	
	402 0129 000	CLIP FUSE	2	
	943 4219 001	PWB ASSY, HV PROTECTION	1	

## SECTION VIII

## DIAGRAMS

8-1. INTRODUCTION

8-2. This section provides schematic diagrams necessary for maintaining the HARRIS MW-5B AM BROADCAST TRANSMITTER. The following diagrams and wire running lists are contained in this section:

<u>Figure</u>	<u>Title</u>	<u>Number</u>	<u>Page</u>
8-1	RF and Overload Assembly 1A2, Schematic	852 8726 001	8-3/8-4
8-2	MW-5B AM BROADCAST TRANSMITTER, Overall Schematic	852 7591 002	8-5/8-6
8-3	Modulation Enhancer 1A1A4, Schematic	839 1066 001	8-7/8-8
8-4	PDM and Audio Driver 1A1, Schematic Sheet 1	839 6354 001	8-9/8-10
8-4	PDM and Audio Driver 1A1, Schematic Sheet 2	839 6354 001	8-11/8-12
8-5	MW-5B Transmitter Frequency Determin- ing Components	839 0114 001	8-13/8-14
8-6	MW-5B Transmitter Control Circuits, Schematic	843 2132 001	8-15/8-16
8-7	High Voltage Protection Circuitry	839 6611 001	8-17/8-18
8-8	Wire Running List (Sheet 1 of 9)	816 5242 002	8-19/8-20
8-8	Wire Running List (Sheet 2 of 9)	816 5242 002	8-21/8-22
8-8	Wire Running List (Sheet 3 of 9)	816 5242 002	8-23/8-24
8-8	Wire Running List (Sheet 4 of 9)	816 5242 002	8-25/8-26
8-8	Wire Running List (Sheet 5 of 9)	816 5242 002	8-27/8-28
8-8	Wire Running List (Sheet 6 of 9)	816 5242 002	8-29/8-30
8-8	Wire Running List (Sheet 7 of 9)	816 5242 002	8-31/8-32
8-8	Wire Running List (Sheet 8 of 9)	816 5242 002	8-33/8-34
8-8	Wire Running List (Sheet 9 of 9)	816 5242 002	8-35/8-36

<u>Figure</u>	<u>Title</u>	<u>Number</u>	<u>Page</u>
8-9	Wire Running List, PDM and Audio (Sheet 1 of 2)	816 5241 005	8-37/8-38
8-9	Wire Running List, PDM and Audio (Sheet 2 of 2)	816 5241 005	8-39/8-40
8-10	Wire Running List, Oscillator and RF Driver Cable (Sheet 1 of 2)	816 4916 001	8-41/8-42
8-10	Wire Running List, Oscillator and RF Driver Cable (Sheet 2 of 2)	816 4916 001	8-43/8-44
8-11	Wire Running List, Low Voltage and Modulator Bias	816 5020 002	8-45/8-46
8-12	Wire Running List, 1A11	816 5041 001	8-47/8-48



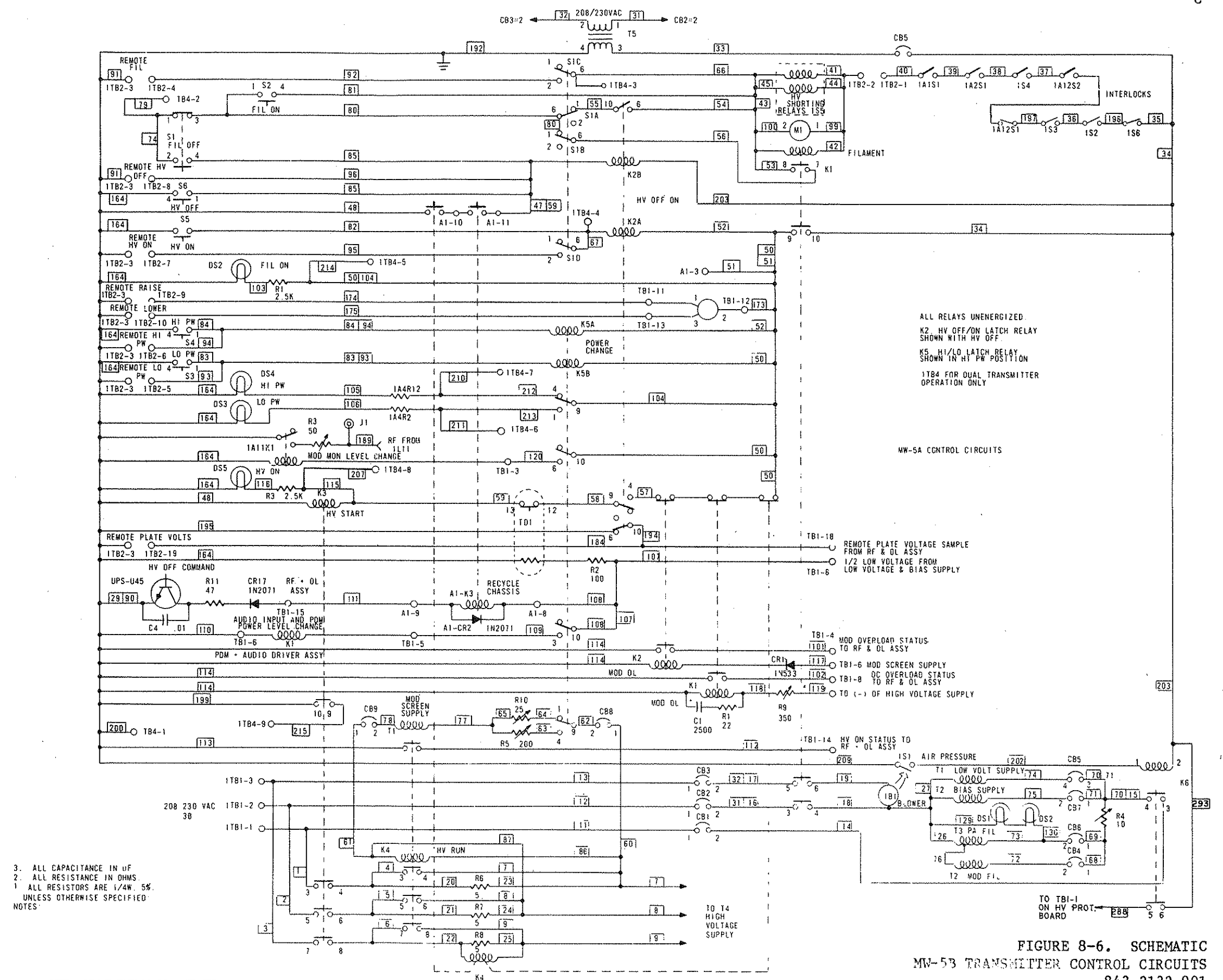

3. ALL CAPACITANCE IN UF  
 2. ALL RESISTANCE IN OHMS  
 1. ALL RESISTORS ARE 1/4W. 5%  
 UNLESS OTHERWISE SPECIFIED  
 NOTES

FIGURE 8-6. SCHEMATIC  
 MW-5B TRANSMITTER CONTROL CIRCUITS  
 843 2132 001

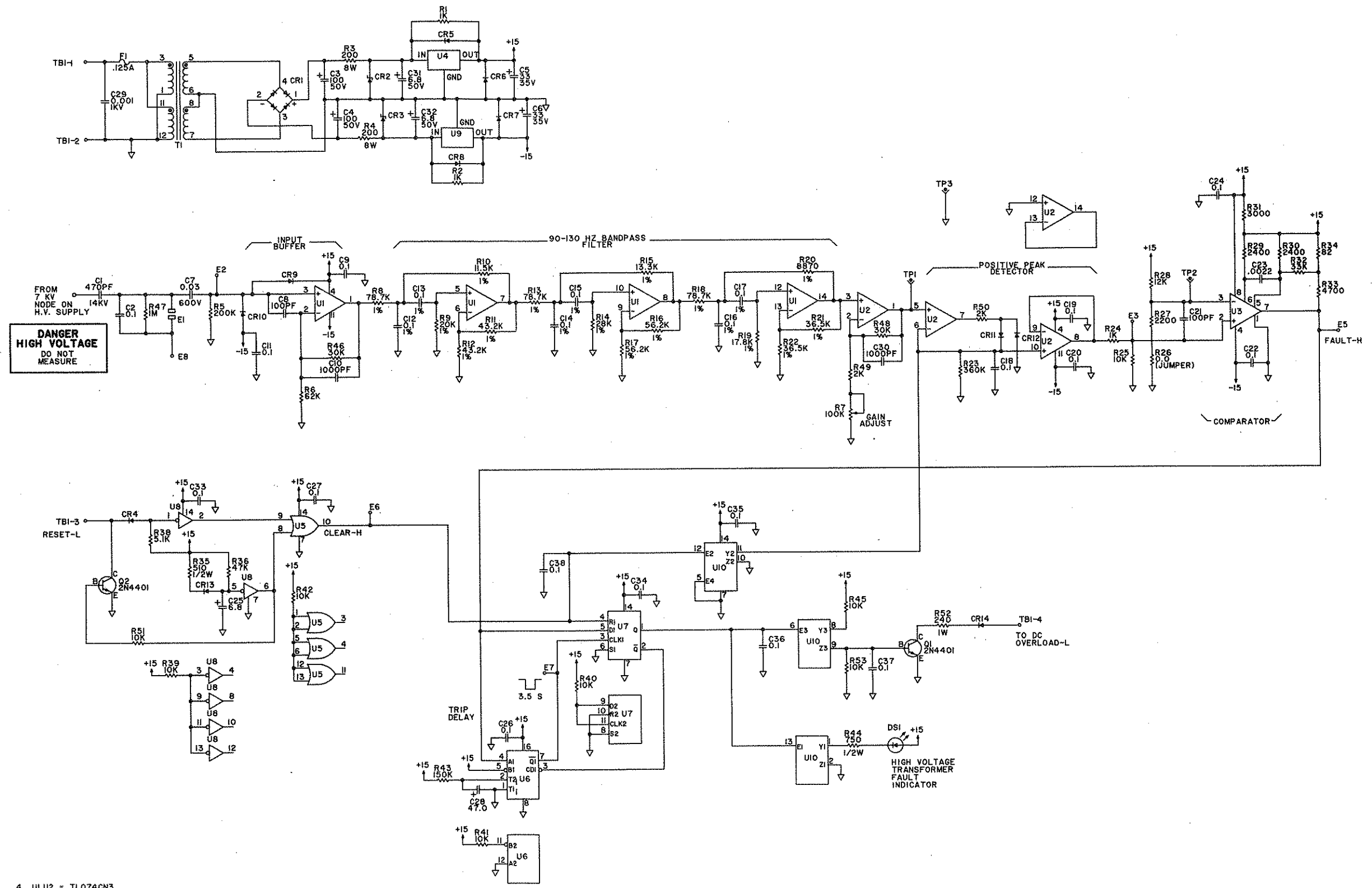

4. U1, U2 = TL074CN3  
 U3 = LM311/CA311  
 U4 = 7815  
 U5 = 4071B  
 U6 = MCI4528BCP  
 U7 = 4013  
 U8 = 4069UB  
 U9 = 7915  
 U10 = MCI4066BCPDS
3. CR1 = VM28  
 CR2, CR3 = IN5359A  
 CR5-CR8 = IN4002  
 CR9-CR14 = IN4001  
 CR4 = IN914
2. ALL RESISTORS ARE IN OHMS, 1/4W, 5%
1. ALL CAPACITANCE IS IN UF  
 UNLESS OTHERWISE NOTED:

If You Didn't Get This From My Site,  
 Then It Was Stolen From...  
[www.SteamPoweredRadio.Com](http://www.SteamPoweredRadio.Com)

FIGURE 8-7. HIGH VOLTAGE PROTECTION CIRCUITRY  
 839 6611 001

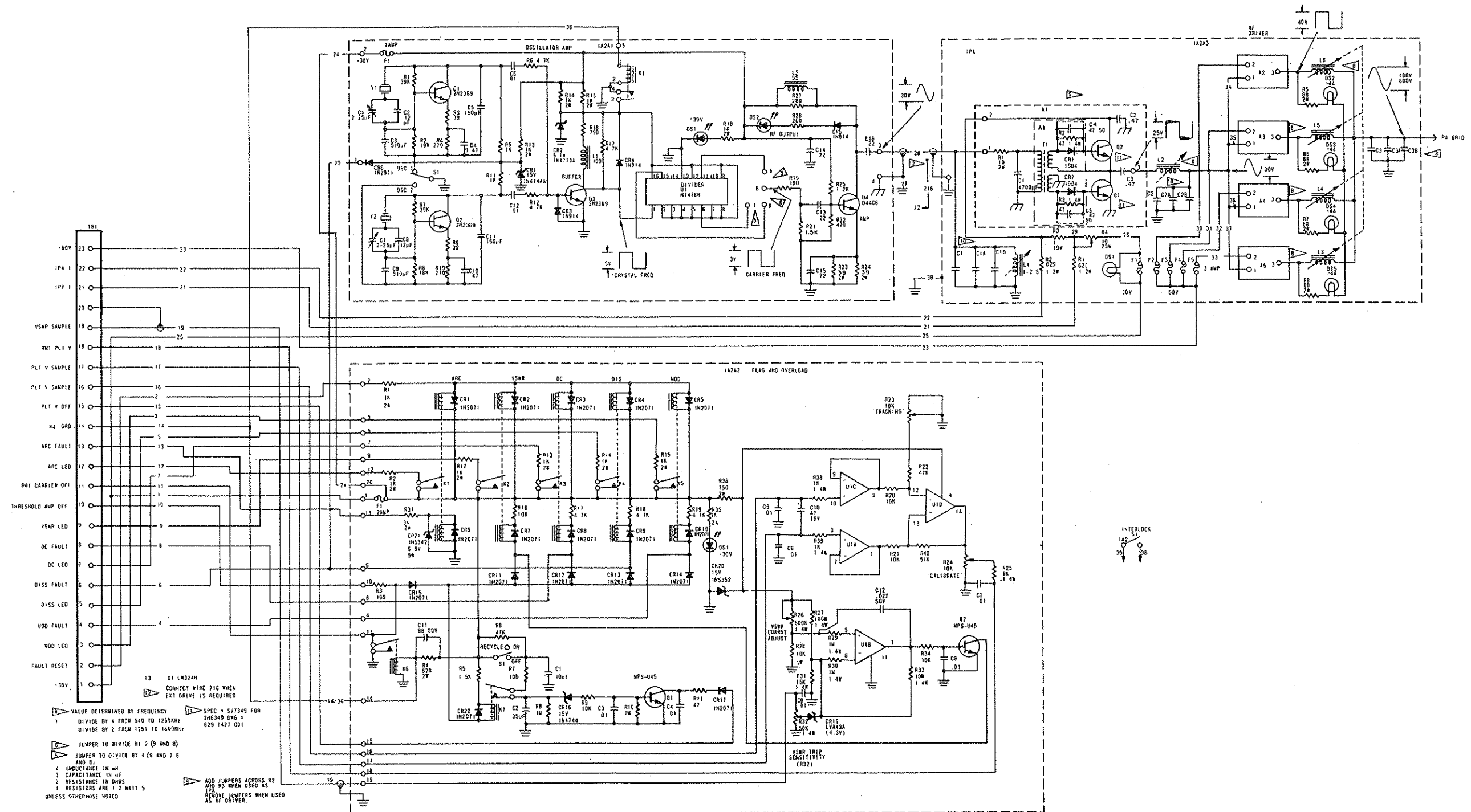
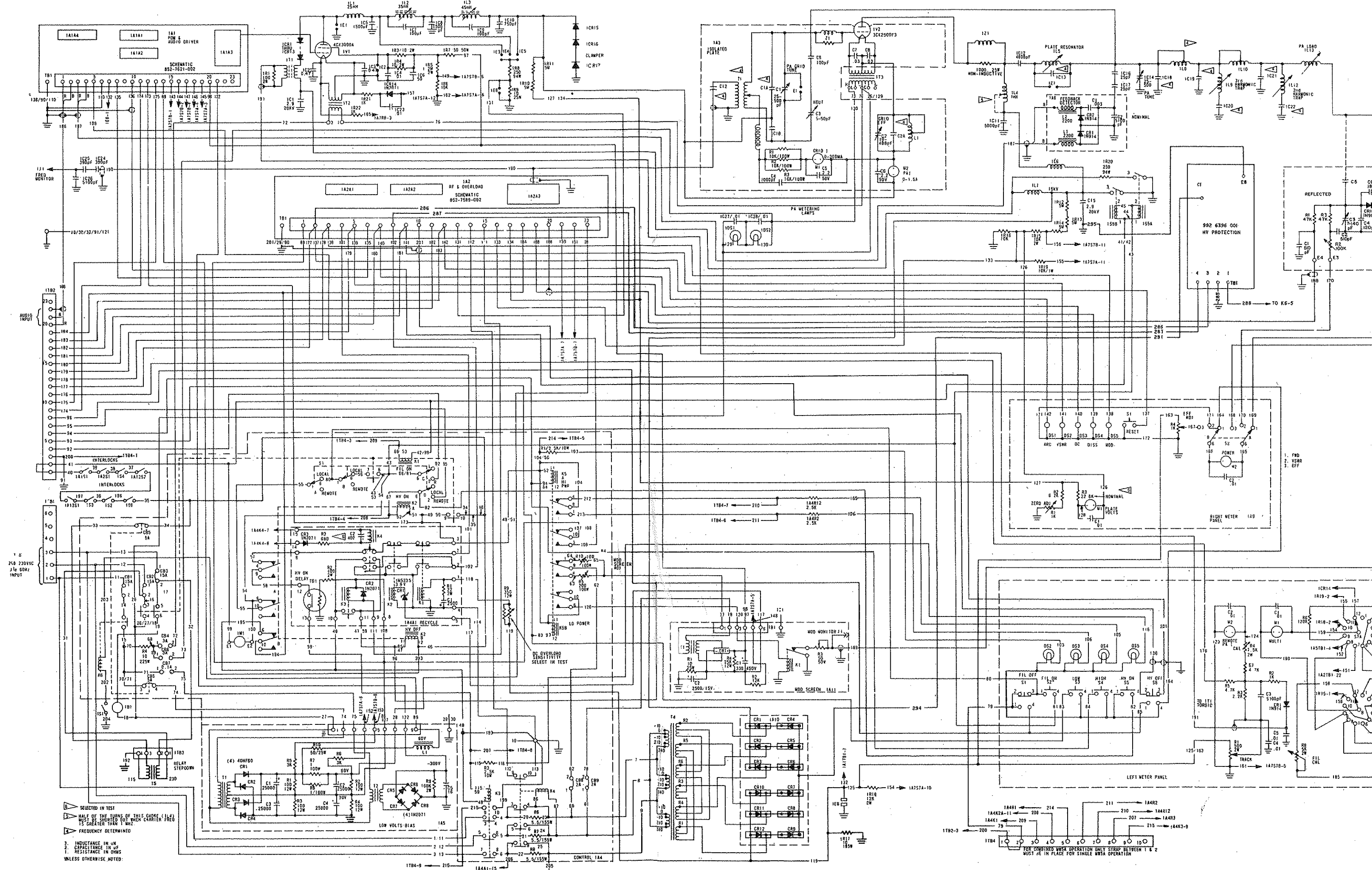
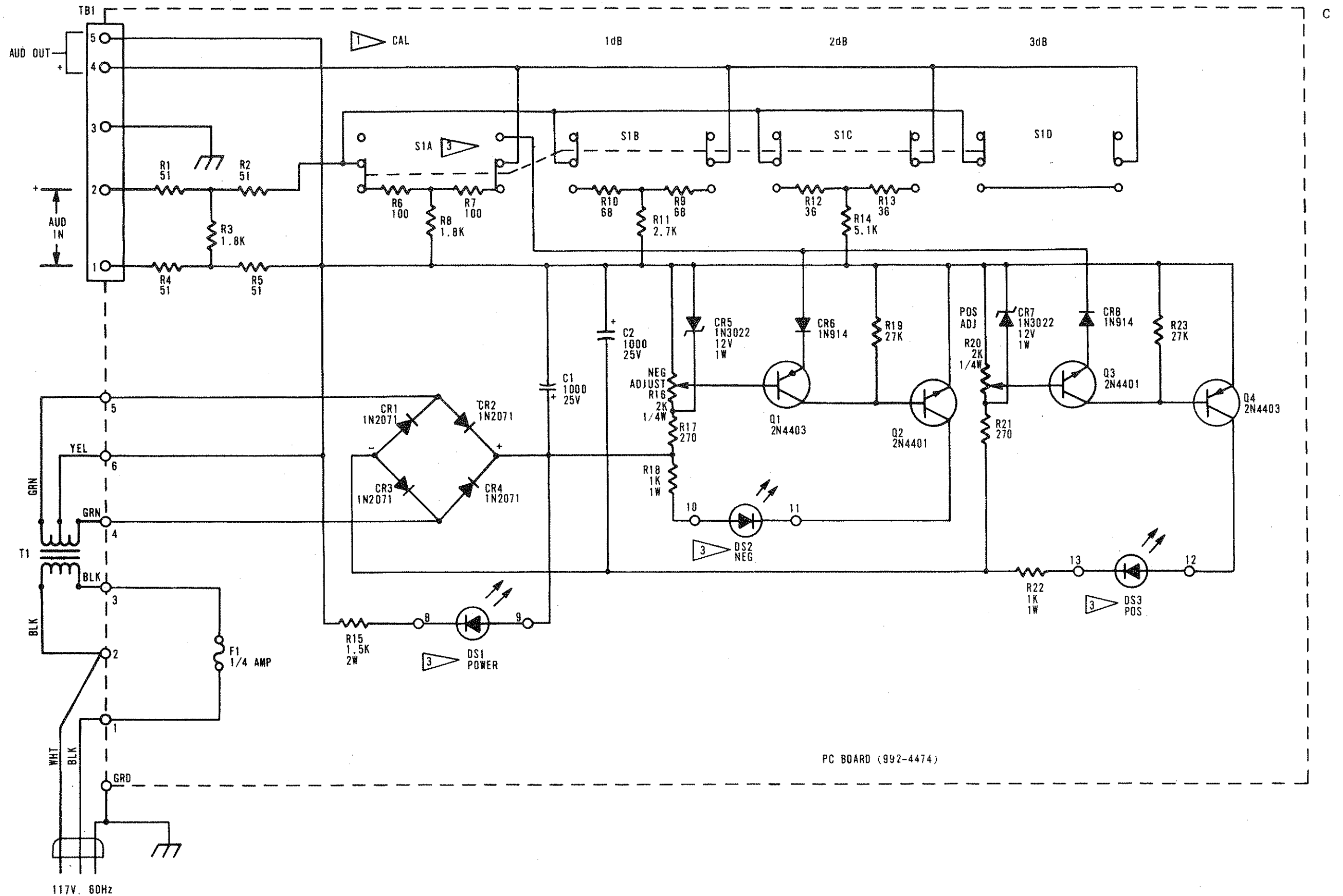

FIGURE 8-1. SCHEMATIC  
RF AND OVERLOAD ASSEMBLY 1A2  
852 8726 001

If You Didn't Get This From My Site,  
Then It Was Stolen From...  
www.SteamPoweredRadio.Com



If You Didn't Get This From My Site,  
Then It Was Stolen From...



NOTES:  
 2 TERM 2 IS + INPUT FROM LIMITER  
 TERM 4 IS + INPUT TO THE TRANSMITTER  
 1 SWITCH IS SHOWN IN CAL POSITION

5 ALL CAPACITORS 1 WATT MICROFARADS UNLESS NOTED  
 4 ALL RESISTORS 1/2 WATT UNLESS NOTES  
 3 COMPONENT MOUNTED ON FRONT PANEL

If You Didn't Get This From My Site,  
 Then It Was Stolen From...  
[www.SteamPoweredRadio.Com](http://www.SteamPoweredRadio.Com)

FIGURE 8-3. SCHEMATIC  
 MODULATIN ENHANCER 1A1A4  
 839 1066 001

888-2109-010  
 8-7/8-8

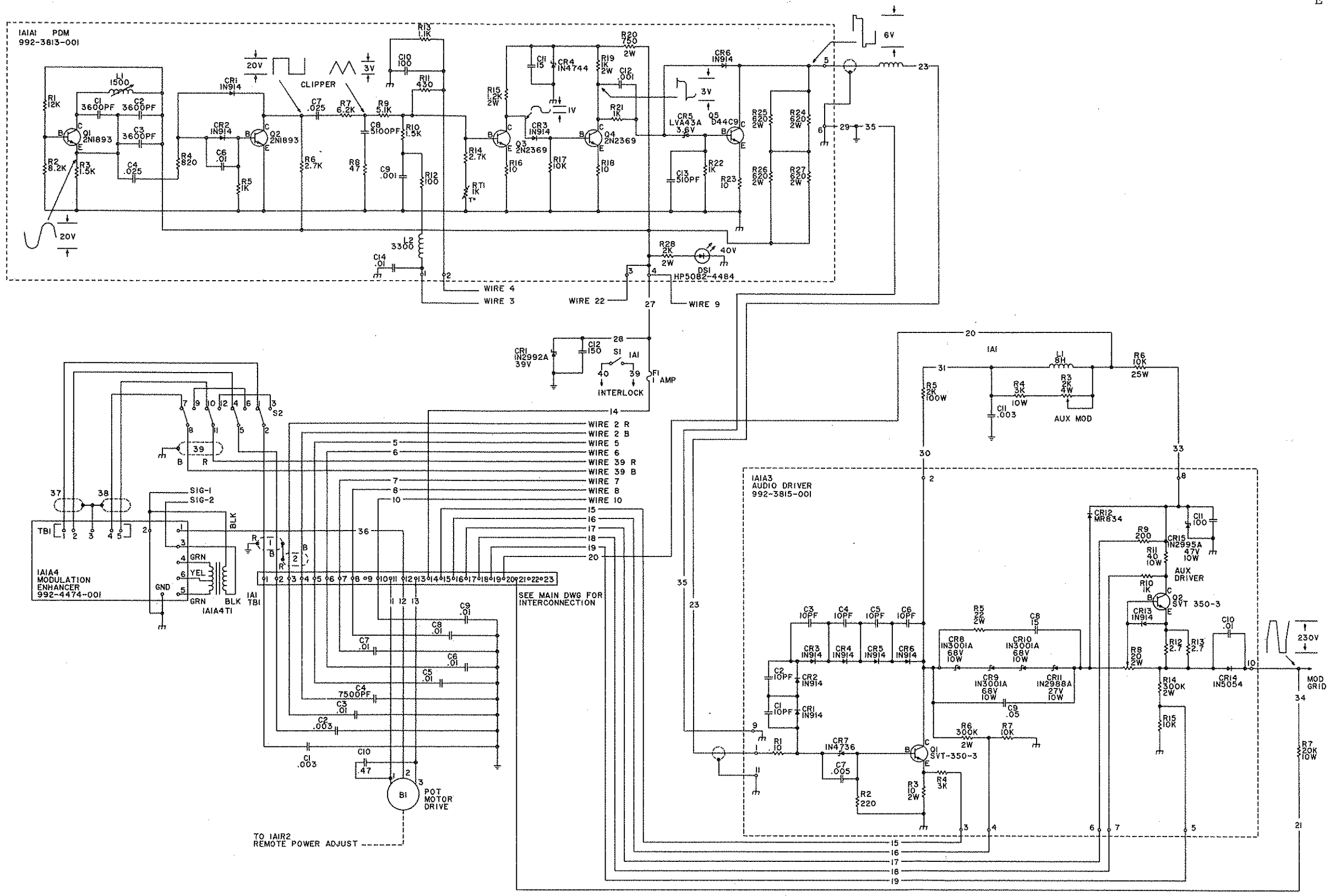
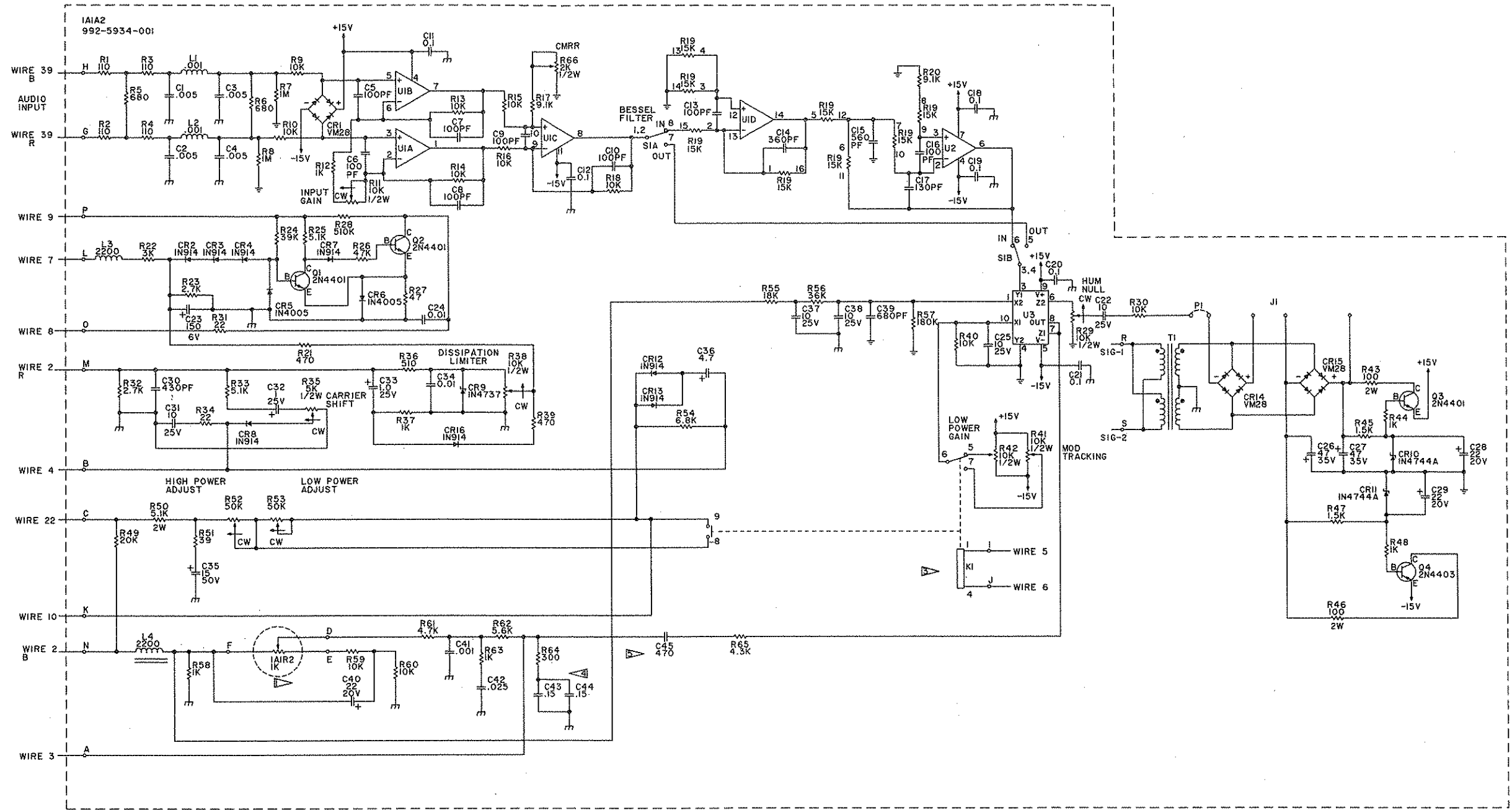

FIGURE 8-4. SCHEMATIC  
PDM AND AUDIO DRIVER 1A1  
(SHEET 1 OF 2)  
839 6354 001

- 4. INDUCTANCE IN UH.
- 3. CAPACITANCE IN UF.
- 2. RESISTANCE IN OHMS.
- 1. RESISTORS ARE 1/2 WATT 5% UNLESS OTHERWISE NOTED.

If You Didn't Get This From My Site,  
Then It Was Stolen From...  
[www.SteamPoweredRadio.Com](http://www.SteamPoweredRadio.Com)



▽ C45 DETERMINES XMTR LF RESPONSE. IT MAY BE DECREASED IN VALUE IF DC OVERLOADS ARE PREVALENT

▽ R64, C43, C44 MAY BE SELECTED IN TEST FOR FLATEST FREQUENCY RESPONSE

▽ KI SHOWN IN RELAXED (LOW POWER) STATE

2. IC IDENTIFICATION:  
 U1 - TL074CN3  
 U2 - TLO71CP3  
 U3 - ADS34JH

▽ NOT ON BOARD. PART OF POT MOTOR DRIVE

FIGURE 8-4. SCHEMATIC  
 PDM AND AUDIO DRIVER IA1  
 (SHEET 2 OF 2)  
 839 6354 001-F

If You Didn't Get This From My Site,  
 Then It Was Stolen From...  
[www.SteamPoweredRadio.Com](http://www.SteamPoweredRadio.Com)

FREQ. kHz	1A2A3 C3	1A2A3 C3A	1A2A3 C3B	TYPE 292 PLATE EFF. C13	VAC TANK PAD C18	VAC C18A	TYPE 293 C19	TYPE 292 C20	TYPE 293 C21	TYPE 293 C22	L8	1A3-C1A, B TYPE 291	1A3-C2A	1A3-T1	1A3-C12	1A2A3-L2	1A2A3 L3, 4, 5, 6
540-590	504-0370-000	504-0370-000	504-0385-000	504-0275-000	512-0056-000	512-0053-000 250pF	504-0354-000	504-0265-000	504-0379-000	504-0378-000	942-4978-001	504-0411-000 1600pF	504-0285-000	943-0005-003	504-0044-000	816-4837-001	816-4838-001
600-640	.01	.01	.005	820pF	500pF	NONE	5100pF	1000pF	4300pF	1200pF			.0039		.006		
650-690	↓	↓	↓	504-0263-000	↓	↓	504-0379-000	504-0275-000	504-0353-000	504-0256-000		504-0410-000 1200pF	504-0041-000	↓	↓		
700-740				500pF			4300pF	820pF	3000pF	1000pF			.003		504-0043-000		
750-790		504-0385-000		↓			↓		↓				↓		.005		
800-840		.005		504-0349-000	↓		504-0353-000	504-0263-000	504-0374-000				943-0005-002		↓		
850-890				240pF	NONE		3000pF	500pF	2000pF				504-0039-000		504-0041-000		
900-940				↓		512-0053-000	↓						.002		.003		
950-990				↓		250pF	↓								↓		
1000-1040	504-0385-000		504-0267-000	504-0348-000			↓		↓			504-0409-000 820pF			943 0005 001	504-0039-000	
1050-1090	.005		.002	150pF			↓		↓						.002		
1100-1140				↓			↓		↓						↓		
1150-1190				↓			504-0374-000		504-0377-000	504-0247-000			504-0037-000		↓		
1200-1240				↓			2000pF		1500pF	500pF			.001		↓		
1250-1290		504-0267-000	504-0368-000	↓								504-0367-000 560pF			504-0038-000		
1300-1340		.002	.003	↓											.0015		
1350-1390				504-0347-000											↓	816-4837-002	816-4838-002
1400-1440				120pF								504-0408-000 400pF			504-0037-000		
1450-1490				↓											.001		
1500-1540	504-0267-000		504-0267-000												504-0283-000		
1550-1590	.002		.002												.00082		
1600-1640	↓	↓	↓	↓			↓	↓	↓	↓	↓	↓	↓	↓	↓	↓	↓

FREQ. kHz	1A2A3 C1	1A2A3 C1A	1A2A3 C2	1A2A3 C2A
540-590	508-0264-000	508-0264-000	508-0264-000	500-1195-000
600-640	.03	.03	.03	.01
650-690	↓	NONE	↓	NONE
700-740				
750-790			508-0261-000	
800-840	508-0261-000		.02	
850-890	.02		500-1195-000	
900-940			.01	
950-990			500-0846-000	
1000-1040			8200	
1050-1090			↓	
1100-1140	500-1195-000		500-0901-000	
1150-1190	.01		6800	
1200-1240	500-0846-000		500-0783-000	
1250-1290	8200		5100	
1300-1340	↓		500-0883-000	
1350-1390	500-0901-000		4700	
1400-1440	6800		↓	
1450-1490	500-0783-000		500-0882-000	
1500-1540	5100		3600	
1550-1590	500-0902-000		500-0845-000	
1600-1640	3300	↓	2000	↓

FIGURE 8-5. MW-5B TRANSMITTER  
FREQUENCY DETERMINING COMPONENTS  
839 0114 001



MM-5 MAIN CABLE

C

DATE		RUNNING SHEET		CABLE NO.	
WIRE NO.	FROM		WIRE SIZE AND TYPE	TO	
	EQUIPMENT	TERMINAL		EQUIPMENT	TERMINAL
1	1A4K3	3	#8 Black Strd.	1TB1	1
2	1A4K3	5	"	1TB1	2
3	1A4K3	7	"	1TB1	3
4	1A4K3	4	#10 Grey Strd.	1A4K4	3
5	1A4K3	6	"	1A4K4	5
6	1A4K3	8	"	1A4K4	7
7	1A4K4	4	"	1T4	01
8	1A4K4	6	"	1T4	02
9	1A4K4	8	"	1T4	03
10	1A4Gnd	Stud	"	Cab. Gnd.	Stud
11	1A4K3	3	#14 Blue Strd.	1A4CB1	1
12	1A4K3	5	"	1A4CB2	1
13	1A4K3	7	"	1A4CB3	1
14	1A4CB1	2	"	1A4K6	3
15	1A4R4	1	"	1A4K6	4
16	1A4CB2	2	"	1A4K1	3
17	1A4CB3	2	"	1A4K1	5
18	1A4K1	4	"	1B1	1
19	1A4K1	6	"	1B1	2
20	1A4K3	4	"	1A4R6	1
21	1A4K3	6	"	1A4R7	1
22	1A4K3	8	"	1A4R8	1
23	1A4R6	2	"	1A4K4	4
24	1A4R7	2	"	1A4K4	6
25	1A4R8	2	"	1A4K4	8
26	1A4K1	4	"	1T3	-
27	1A4K1	4	"	1A5TB1	1
28	1A2TB1	23	#14 Blue Strd.	1A5TB1	7

FIGURE 8-8. WIRE RUNNING LIST  
(SHEET 1 OF 9)  
816 5242 002

888-2109-010  
8-19/8-20

DATE		RUNNING SHEET		CABLE NO.	
WIRE NO	FROM		WIRE SIZE AND TYPE	TO	
	EQUIPMENT	TERMINAL		EQUIPMENT	TERMINAL
29	1A2Gnd.	Stud	#14 Blue Strd.	1A5Gnd.	Stud
30	1A5Gnd	Stud	#14 Blue Strd.	Cab. Gnd.	Stud
31	1TB3	1	#16 Brown Strd.	1A4K1	3
32	1TB3	2	"	1A4K1	5
33	1TB3	3	"	1A4CB5	1
34	1A4CB5	2	"	1A4K1	10
35	1A4K1	10	"	1S6	N.O.
36	1S2	c	"	1S3	N.O.
37	1A72S2	c	"	1S4	N.O.
38	1S4	c	"	1A2S1	N.O.
39	1A2S1	c	"	1A1S1	N.O.
40	1A1S1	c	"	1TB2	1
41	1S5B	1	"	1TB2	2
42	1S5A	1	"	1A4K1	2
43	1S5A	2	"	1A4K1	8
44	1S5A	1	"	1S5B	1
45	1S5A	2	"	1S5B	2
46	1A4K1	10	"	1A4K2B	12
47	1A4K2B	11	"	1A4A1	11
48	1A4A1	10	"	1A4K3	2
49	1A4K1	9	"	1A4A1	3
50	1A4K1	9	"	1A4R1	1
51	1A4A1	3	"	1A4K2A	12
52	1A4K2A	12	"	1A4K5A	11
53	1A4K1	1	"	1A4K1	8
54	1A4K1	8	"	1A4K2A	6
55	1A4K2A	10	"	1A4S1A	1
56	1A4S1B	6	#16 Brown Strd.	1A4K1	7

FIGURE 8-8. WIRE RUNNING LIST  
(SHEET 2 OF 9)  
816 5242 002

888-2109-010  
8-21/8-22

WARNING: Disconnect primary power prior to servicing.

DATE		RUNNING SHEET		CABLE NO.	
WIRE NO.	FROM		WIRE SIZE AND TYPE	TO	
	EQUIPMENT	TERMINAL		EQUIPMENT	TERMINAL
57	1A4K2A	4	#16 Brown Strd.	1A4A1	6
58	1A4K2A	9	"	1A4A1	12
59	1A4K1	1	"	1A4A1	13
60	1A4K4	4	"	1A4CB8	1
61	1A4P4	6	"	1A4CB9	1
62	1A4CB8	2	"	1A4K5B	9
63	1A4K5B	4	"	1A4R5	1
64	1A4K5B	1	"	1A4R10	1
65	1A4R5	3	"	1A4R10	3
66	1A4K1	1	"	1A4S1C	6
67	1A4K2A	11	"	1A4S1D	6
68	1A4R4	3	"	1A4CB4	1
69	1A4R4	3	"	1A4CB6	1
70	1A4R4	1	"	1A4CB5	3
71	1A4CB5	3	"	1A4CB7	1
72	1A4CB4	2	"	1T2	3
73	1A4CB6	2	"	1T3	H
74	1A4CB5	4	"	1A5TB1	2
75	1A4CB7	2	"	1A5TB1	3
76	1T2	1	"	1T3	-
77	1A4R5	3	"	1A11TB1	1
78	1A4CB9	2	"	1A11TB1	2
79	1TB4	2	"	1A7S1	2
80	1A4S1A	6	"	1A7S1	3
81	1A4S1C	6	"	1A7S2	4
82	1A4S1D	6	"	1A7S5	1
83	1A4K5B	12	"	1A7S3	1
84	1A4F3A	12	#16 Brown Strd.	1A7S4	1

FIGURE 8-8. WIRE RUNNING LIST  
(SHEET 3 OF 9)  
816 5242 002

888-2109-010  
8-23/8-24

DATE 8-16-73		RUNNING SHEET		CABLE NO.	
WIRE NO	FROM		WIRE SIZE AND TYPE	TO	
	EQUIPMENT	TERMINAL		EQUIPMENT	TERMINAL
85	1A4K1B	11	#16 Brown Strd.	1A7S6	1
86	1A4R6	2	"	1A4K4	1
87	1A4R7	2	"	1A4K4	2
88	1A5TB1	6	"	1A2TB1	1
89	1A1TB1	14	"	1A5TB1	9
90	1A1Gnd.	Stud	"	1A2Gnd.	Stud
91	Cab. Gnd.	Stud	"	1TB2	3
92	1A4S1C	2	"	1TB2	4
93	1A4K5B	12	"	1TB2	5
94	1A4K5A	12	"	1TB2	6
95	1A4S1D	2	"	1TB2	7
96	1A4K2B	11	#16 Brown Strd.	1TB2	8
97	1A1TB1	4	#18 Red Strd.	1R7	2
98	1A1TB1	4	#18 Red Strd.	1A1TB1	20
99	1A4M1	1	#20 White Strd.	1A4K1	2
100	1A4M1	2	"	1A4K2A	6
101	1A4A1	7	"	1A2TB1	4
102	1A4A1	2	"	1A2TB1	8
103	1A4R1	2	"	1A7DS2	1
104	1A4R1	1	"	1A4K5A	9
105	1A4R12	1	"	1A7DS4	1
106	1A4R2	1	"	1A7DS3	1
107	1A4K5A	10	"	1A5TB1	6
108	1A4K5A	10	"	1A4A1	8
109	1A4K5A	3	"	1A1TB1	5
110	1A1TB1	6	"	1A1Gnd.	Stud
111	1A4A1	7	"	1A2TB1	15
112	1A4K4	9	#20 White Strd.	1A2TB1	14

FIGURE 8-8. WIRE RUNNING LIST  
(SHEET 4 OF 9)  
816 5242 002

888-2109-010  
8-25/8-26

DATE		RUNNING SHEET		CABLE NO.	
WIRE NO	FROM		WIRE SIZE AND TYPE	TO	
	EQUIPMENT	TERMINAL		EQUIPMENT	TERMINAL
113	1A4K4	10	#20 White Strd.	1A4Gnd.	Stud
114	1A4A1	4	"	1A4Gnd.	Stud
115	1A4R3	1	"	1A4K3	1
116	1A4R3	2	"	1A7DS5	1
117	1A4A1	5	"	1A11TB1	6
118	1A4A1	1	"	1A4R9	1
119	1A4R9	3	"	1R17	1
120	1A4K5B	6	"	1A11TB1	3
121	Cab. Gnd.	Stud	"	1A11Gnd.	Stud
122	1A5TB1	8	"	1A1TB1	21
123	1A7M2	+	"	1A7R1	Gnd. Lug.
124	1A7M2	-	"	1A7R4	1
125	1R17	1	"	1A7R1	3
126	1R15	2	"	1A9M1	+
127	1R10	2	"	1A9R3	1
128	1A9R3	2	"	1A9M1	-
129	1T3	-	"	1DS1	1
130	1T3	H	"	1DS2	2
131	1R9	1	"	1A2TB1	13
132	1E8	1	"	1A1TB1	7
133	1R16	1	"	1A2TB1	16
134	1R10	2	"	1A2TB1	17
135	1A1TB1	8	"	1A2TB1	6
136	1A1TB1	10	Coax RG196U	1A7S6	2
Shld	1A1TB1	Gnd Stud	Coax RG196U	1A7S6	Gnd
137	1A2TB1	2	No.20 White Strd.	1A9S1	C
138	1A2TB1	3	"	1A9DS5	1
139	1A2TB1	5	"	1A9DS4	1
140	1A2TB1	7	#20 White Strd.	1A9DS3	1

E

FIGURE 8-8. WIRE RUNNING LIST  
(SHEET 5 OF 9)  
816 5242 002

888-2109-010  
8-27/8-28

DATE		RUNNING SHEET		CABLE NO.	
WIRE NO	FROM		WIRE SIZE AND TYPE	TO	
	EQUIPMENT	TERMINAL		EQUIPMENT	TERMINAL
141	1A2TB1	9	#20 White Strd.	1A9DS2	1
142	1A2TB1	12	"	1A9DS1	1
143	1A1TB1	15	"	1A7S7B	1
144	1A1TB1	16	"	1A7S7B	2
145	1A1TB1	19	"	1A7S7A	3
146	1A1TB1	18	"	1A7S7A	4
147	1A1TB1	17	"	1A7S7B	4
148	1A11TB1	5	"	1A7S7A	5
149	1R5	2	"	1A7S7B	6
150	1A2TB1	21	"	1A7S7B	7
151	1A2TB1	22	"	1A7S7A	7
152	1A5TB1	4	"	1A7S7A	8
153	1A5TB1	5	"	1A7S7B	8
154	1R18	2	"	1A7S7A	10
155	1R15	3	"	1A7S7A	11
156	1R19	2	"	1A7S7B	11
157	1CR14	ANODE	"	1A7S7A	12
158	1R8	1	"	1A7S7B	12
159	1A7M1	-	"	1A7S7A	13
160	1A7M1	+	"	1A7S7B	13
161	1A7R1	Gnd. Lug	"	1A7S7B	5
162	1R6	Gnd Lug	"	1A7S7A	6
163	1A7R1	3	"	1A9R4	3
164	1A7S6	4	"	1A9S2B	1
165	1A9S2A	6	"	1A9M2	-
166	1A9S2B	6	"	1A9M2	+
167	1A9R4	2	"	1A9S2B	3
168	1A8E1	1	#20 White Strd.	1A9S2A	3

FIGURE 8-8. WIRE RUNNING LIST

(SHEET 6 OF 9)

816 5242 002

888-2109-010

8-29/8-30

DATE		RUNNING SHEET		CABLE NO.	
WIRE NO.	FROM		WIRE SIZE AND TYPE	TO	
	EQUIPMENT	TERMINAL		EQUIPMENT	TERMINAL
190	1A2A3C3	2	RG/58 Coax (Center Conductor)	1C2L	
190	1A2A3C3	1	" " (Shield)	1J1	Gnd
191	1T1	1	RG/196 Coax (Center Conductor)	1A7CR1	Cathode
191	1T1	2	" " (Shield)	1A7C3	2
192	1TB3	4	#16 Brown Strd.	Cab. Gnd	Stud
193	1A4K3	2	#16 Brown Strd.	1A4 Grd	Stud
194	1A4K2B	10	#20 White	1A2TB1	18
195	1A4K2B	6	#20 White	1A4 Grd.	Stud
196	1S2	C	#16 Brown	1S6	N.O.
197	1S3	C	#16 Brown	1A12S1	C
198	1TB1	4	#10 Gray	1A4E3	Stud
199	1A4K3	10	#20 White	1A4'Grd	Stud
200	1TB2	3	#16 Brown	1TB4	1
201	1A2TB1	10	Coax RG196U	1A7S6	3
Shield	1A2TB1	Gnd Stud	Coax RG196U	1A7S6	Gnd
202	1A4K6	1	#20 White	1S1	C
203	1A4K6	2	#20 White	1A4K2B	12
204	1S1	NO	#20 White	Gnd Lug	AT 1R16
205	1A4A1	14	#16 Brown	1A4R8	2
206	1A4A1	15	#16 Brown	1A4R8	1
207	1A4R3	1	#20 white	1TB4	8
208	1A4K2A	11	"	1TB4	4
209	1A4K1	1	"	1TB4	3
210	1A4R12	2	"	1TB4	7
211	1A4R2	2	"	1TB4	6
212	1A4K5A	4	"	1A4R12	2
213	1A4K5A	1	"	1A4R2	2
214	1A4R1	1	"	1TB4	5
215	1TB4	9	"	1A4K3	9

E

FIGURE 8-8. WIRE RUNNING LIST  
(SHEET 8 OF 9)  
816 5242 002

888-2109-010  
8-33/8-34





DATE	RUNNING SHEET		816 5241 005	CABLE NO.	See Sheet 1	
WIRE NO.	FROM		WIRE SIZE AND TYPE	TO		
	EQUIPMENT	TERMINAL		EQUIPMENT	TERMINAL	
1R	1A1TB1	1	BELDEN 8451 253-0059-000	S2	2	
1B	1A1TB1	2	BELDEN 8451 253-0059-000	S2	5	
1S	1A1GND	GND STUD	BELDEN 8451 253-0059-000	OUT	OFF	
2R	1A1TB1	3	BELDEN 8451 253-0059-000	1A1A2	M	
2B	1A1TB1	4	BELDEN 8451 253-0059-000	1A1A2	N	
2S	1A1GND	GND STUD	BELDEN 8451 253-0059-000	OUT	OFF	
3	1A1A1	1	#20 WHITE 252-0003-000	1A1A2	A	
4	1A1A1	2	#20 WHITE 252-0003-000	1A1A2	B	
5	1A1TB2	5	#20 WHITE 252-0003-000	1A1A2	I	
6	1A1TB1	6	#20 WHITE 252-0003-000	1A1A2	J	
7	1A1TB1	7	#20 WHITE 252-0003-000	1A1A2	L	
8	1A1TB1	8	#20 WHITE 252-0003-000	1A1A2	O	
9	1A1A1	4	#20 WHITE 252-0003-000	1A1A2	P	
10	1A1TB1	10	#20 WHITE 252-0003-000	1A1A2	K	
11	1A1TB1	11	#20 WHITE 252-0003-000	1A1B1	1	
12	1A1TB1	12	#20 WHITE 252-0003-000	1A1B1	2	
13	1A1TB1	13	#20 WHITE 252-0003-000	1A1B1	3	
14	1A1TB1	14	#16 BROWN 252-0005-000	1A1XF1	1	
15	1A1TB1	15	#20 WHITE 252-0003-000	1A1A3	3	
16	1A1TB1	16	#20 WHITE 252-0003-000	1A1A3	4	
17	1A1TB1	17	#20 WHITE 252-0003-000	1A1A3	6	
18	1A1TB1	18	#20 WHITE 252-0003-000	1A1A3	7	
19	1A1TB1	19	#20 WHITE 252-0003-000	1A1A3	5	
20	1A1TB1	20	#20 WHITE 252-0003-000	1A1R6	1	
21	1A1TB1	21	#20 WHITE 252-0003-000	1A1R7	2	
22	1A1A1	3	#20 WHITE 252-0003-000	1A1A2	C	

FIGURE 8-9. WIRE RUNNING LIST  
PDM AND AUDIO  
(SHEET 1 OF 2)  
816 5241 005

888-2109-010  
8-37/8-38

DATE		RUNNING SHEET		816 5241 005		CABLE NO.	
7-24-81						See Sheet 1	
WIRE NO.	FROM		WIRE SIZE AND TYPE	TO			
	EQUIPMENT	TERMINAL		EQUIPMENT	TERMINAL		
23W	1A1A1	5	RG196/U COAX 618-0206-000	1A1A3	1		
23S	1A1A1	6	RG196/U COAX 618-0206-000	1A1A3	11		
24	1A1R2	1	#20 WHITE 252-0003-000	1A1A2	E		
25	1A1R2	2	#20 WHITE 252-0003-000	1A1A2	D		
26	1A1R2	3	#20 WHITE 252-0003-000	1A1A2	F		
27	1A1XF1	2	#20 WHITE 252-0003-000	1A1A1	4		
28	1A1XF1	2	#20 WHITE 252-0003-000	1A1CR1	CATHODE		
29	1A1GND	STUD	#20 WHITE 252-0003-000	1A1A1	6		
30	1A1A3	2	#20 WHITE 252-0003-000	1A1R5	2		
31	1A1R4	1	#20 WHITE 252-0003-000	1A1R5	1		
33	1A1R6	2	#20 WHITE 252-0003-000	1A1A3	8		
34	1A1R7	1	#20 WHITE 252-0003-000	1A1A3	10		
35	1A1GND	STUD	#20 WHITE 252-0003-000	1A1A3	9		
36	1A1TB1	12	#20 WHITE 252-0003-000	1A1A4	2		
37R	S2	1	BELDEN 8451 253-0059-000	1A1A4-TB1	1		
37B	S2	4		1A1A4-TB1	2		
37S	CUT OFF			1A1A4-TB1	3		
38R	S2	7	BELDEN 8451 253-0059-000	1A1A4-TB1	4		
38B	S2	10		1A1A4-TB1	5		
38S	CUT OFF			1A1A4-TB1	3		
39R	S2	11	BELDEN 8451 253-0059-000	1A1A2	G		
39B	S2	8	BELDEN 8451 253-0059-000	1A1A2	H		
39S	S2	GND STUD		CUT OFF			
40	1A2TB1	2	#20 STRANDED	1A2A2	P		
41	1A1A4	3	#20 STRANDED	1A2A2	R		

FIGURE 8-9. WIRE RUNNING LIST  
PDM AND AUDIO  
(SHEET 2 OF 2)  
816 5241 005

888-2109-010  
8-39/8-40

O.L., OSC and R.F. DVR, CABLE

DATE		RUNNING SHEET			CABLE NO.	
WIRE NO.	FROM		WIRE SIZE AND TYPE	TO		
	EQUIPMENT	TERMINAL		EQUIPMENT	TERMINAL	
1	1A2TB1	1	# 16	Brown std	1A2A2	1
2	1A2TB1	2	# 20	white "	1A2A2	2
3	1A2TB1	3	# 20	" "	1A2A2	3
4	1A2TB1	4	# 20	" "	1A2A2	4
5	1A2TB1	5	# 20	" "	1A2A2	5
6	1A2TB1	6	# 20	" "	1A2A2	6
7	1A2TB1	7	# 20	" "	1A2A2	7
8	1A2TB1	8	# 20	" "	1A2A2	8
9	1A2TB1	9	# 20	" "	1A2A2	9
10	1A2TB1	10	# 20	" "	1A2A2	10
11	1A2TB1	11	# 20	" "	1A2A2	11
12	1A2TB1	12	# 20	" "	1A2A2	12
13	1A2TB1	13	# 20	" "	1A2A2	13
14	1A2TB1	14	# 20	" "	1A2A2	14
15	1A2TB1	15	# 20	" "	1A2A2	15
16	1A2TB1	16	# 20	" "	1A2A2	16
17	1A2TB1	17	# 20	" "	1A2A2	17
18	1A2TB1	18	# 20	" "	1A2A2	18
19W	1A2TB1	19	8411	Belden	1A2A2	19
19S	1A2TB1	20	"	"	1A2A2	Grnd
20	1A2A1	1	# 20	white std.	1A2A2	6
21	1A2TB1	21	# 20	" "	1A2A3R1	1
22	1A2TB1	22	# 20	" "	1A2A3R2	1
23	1A2TB1	23	# 14	Blue "	1A2A3XF2	1
24	1A2A2	20	# 16	Brown "	1A2A1	2
25	1A2TB1	1	# 16	" "	1A2A3XF1	1
26	1A2A3XF1	2	# 20	white "	1A2A3R4	1
27	1A2A1	4	# 20	"	1A2Grnd	Stud

FIGURE 8-10. WIRE RUNNING LIST  
OSCILLATOR AND RF DRIVER CABLE  
(SHEET 1 OF 2)

816 4916 001

888-2109-010  
8-41/8-42



LOW VOLTAGE AND MOD. BIAS SUPPLY CABLE

DATE		RUNNING SHEET 1A5		CABLE NO.	
WIRE NO	FROM		WIRE SIZE AND TYPE	TO	
	EQUIPMENT	TERMINAL		EQUIPMENT	TERMINAL
1	1A5TB1	1	#16 Strd.	1A5T1	1
2	1A5TB1	2	#16 "	1A5T1	3
3	1A5TB1	3	#20 "	1A5T2	3
4	1A5TB1	4	#20 "	1A5R6	1
5	1A5TB1	5	#20 "	1A5R5	1
6	1A5TB1	6	#16 "	1A5T1	5
7	1A5TB1	7	#14 "	1A5R7	2
8	1A5TB1	8	#20 "	1A5C5	-
9	1A5TB1	9	#16 "	1A5L1	TP
10	1A5T1	4	#14 "	1A5CR1	Anode
11	1A5T1	6	#14 "	1A5CR3	Anode
12	1A5C2	+	#14 "	1A5R7	?
13	1A5CR1	Cathode	#14 "	1A5R7	1
14	1A5C1	+	#14 "	1A5R7	1
15	1A5T1	5	#16 "	1A5C's	Com. strap
16	1A5TB1	1	#20 "	1A5T2	1
17	1A5T2	4	#20 "	1A5CR6	Anode
18	1A5T2	5	#20 "	1A5CR8	Anode
19	1A5R10	1	#14 "	1A5C1	+
JUMPERS					
	1A5C4	-	#14 "	1A5C4	Gnd. Stud
	1A5C4	-	#14 "	1A5C3	-
	1A5CR2	Anode	#14 "	1A5CR2 & 4	Gnd. Stud
	1A5CR4	Anode	#14 "	1A5CR2 & 4	Gnd. Stud
	1A5CR1	Anode	#14 "	1A5CR2	Cathode
	1A5CR3	Anode	#14 "	1A5CR4	Cathode
	1A5CR1	Cathode	#14 "	1A5CR3	Cathode

FIGURE 8-11. WIRING RUNNING LIST  
 LOW VOLTAGE AND MODULATOR BIAS  
 816 5020 002

888-2109-010  
 8-45/8-46

If You Didn't Get This From My Site,  
 Then It Was Stolen From...

MOD. SCREEN SUPPLY AND MOD. MON. CABLE

DATE		RUNNING SHEET 1A11		CABLE NO.	
WIRE NO	FROM		WIRE SIZE AND TYPE	TO	
	EQUIPMENT	TERMINAL		EQUIPMENT	TERMINAL
1	1A11T1	1	#16 STRD.	1A11T1	1
2	1A11T1	2	#16 "	1A11T1	3
3	1A11T1	3	#20 "	1A11K1	2
4	1A11T1	4	#18 "	1A11C1	+
5	1A11T1	5	#20 "	1A11R2	2
6	1A11T1	6	#20 "	1A11R1	1
7	1A11T1	4	#18 "	1A11C1	AC1
8	1A11T1	5	#18 "	1A11C1	AC2
9	1A11C1	+	#18 "	1A11C1	+
10	1A11C1	-	#18 "	1A11C1	-
11	1A11C1	-	#18 "	1A11R1	1
JUMPERS					
	1A11R1	2	#18 "	1A11R1	Gnd. Lug
	1A11K1	1	#20 "	1A11K1	Gnd. Lug
	1A11K1	1	#20 Buss	1A11K1	3
	1A11K1	5	#20 Strd.	1A11R3	2
	1A11R3	1	#20 "	1A11J1	Center
	1A11R3	1	#20 "	1A11R3	Wiper

FIGURE 8-12. WIRE RUNNING LIST  
1A11

816 5041 001

888-2109-001  
8-47/8-48

APPENDIX A

DATA

APPENDIX A

DATA

A-1. INTRODUCTION

A-2. This appendix contains the following data pertaining to the HARRIS MW-5B AM BROADCAST TRANSMITTER.

DATA SHEET

3CX2500F3/8251

4CX3000A/8169

ENGINEERING NEWSLETTER

LIFE VS FILAMENT VOLTAGE

HARRIS ENGINEERING

POWER DISTRIBUTION RECOMMENDATION



**Eimac**

**E I M A C**

**8251**  
**3CX2500F3**

**MEDIUM MU**  
**TRIODE**

The EIMAC 3CX2500F3 is an all ceramic and metal, medium-mu, forced-air cooled, external anode transmitting triode with a maximum plate dissipation rating of 2500 watts. Relatively high power output as an amplifier, oscillator, or modulator may be obtained from this tube at low plate voltages. The 3CX2500F3 is an exact replacement for the EIMAC 3X2500F3 and is suggested for use where higher ambient temperatures are to be expected or greater reliability is required. The all ceramic and metal construction allows a greater margin of safety with respect to tube operating temperatures while permitting higher processing temperatures to insure longer life.

The tube is equipped with flexible filament and grid leads which simplify socketing and equipment design for industrial and communication frequencies below 30 megahertz.

**GENERAL CHARACTERISTICS**

**ELECTRICAL**

	<u>Min.</u>	<u>Nom.</u>	<u>Max.</u>	
Filament: Thoriated Tungsten				
Voltage	-	7.5		volts
Current	-	48	53	amperes
Amplification Factor	-	19	26	
Direct Interelectrode Capacitances				
Grid-Plate	-	16.8	23.2	pF
Grid-Filament	-	29.2	40.2	pF
Plate-Filament	-	0.6	1.2	pF
Transconductance (Ib=830 ma., Eb=3000 v.)	-	20,000		umhos
Highest Frequency for Maximum Ratings	-		30	MHz

**MECHANICAL**

Base	-	-	-	-	-	See outline drawing
Mounting	-	-	-	-	-	Vertical, base down or up
Maximum Anode Core and Seal Temperatures	-	-	-	-	-	250°C
Cooling	-	-	-	-	-	Forced Air
Maximum Over-all Dimensions:						
Length (Does not include filament connectors)	-	-	-	-	-	8.6 inches
Diameter	-	-	-	-	-	4.16 inches
Length of filament Connectors (Approximate)	-	-	-	-	-	9.5 inches
Net Weight	-	-	-	-	-	7.5 pounds
Shipping Weight (Approximate)	-	-	-	-	-	17 pounds

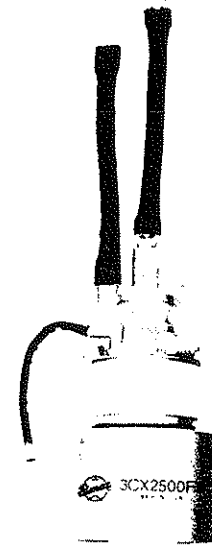

**RADIO-FREQUENCY POWER**  
**AMPLIFIER OR OSCILLATOR**

Conventional Neutralized Amplifier,  
Class-C FM or Telegraphy  
(Key-down Conditions)

**MAXIMUM RATINGS**

DC PLATE VOLTAGE	-	6000	VOLTS
DC PLATE CURRENT	-	2.5	AMPS
PLATE DISSIPATION	-	2500	WATTS
GRID DISSIPATION	-	150	WATTS

**TYPICAL OPERATION (Frequencies below 30 MHz)**

DC Plate Voltage	-	-	-	4000	5000	6000	volts
DC Plate Current	-	-	-	2.5	2.5	2.08	amps
DC Grid Voltage	-	-	-	-300	-450	-500	volts
DC Grid Current	-	-	-	245	265	180	ma
Peak RF Grid Input Voltage*	-	-	-	580	750	765	volts
Driving Power*	-	-	-	142	197	136	watts
Grid Dissipation*	-	-	-	68	78	46	watts
Plate Input Power	-	-	-	-	10,000	12,500	watts
Plate Dissipation	-	-	-	2500	2500	2500	watts
Plate Output Power	-	-	-	7500	10,000	10,000	watts

\*Approximate values.

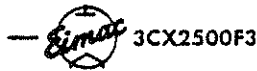

**PLATE-MODULATED RADIO-FREQUENCY AMPLIFIER**  
 Conventional Neutralized Amplifier,  
 Class-C Telephony (Carrier Conditions)

**MAXIMUM RATINGS**

DC PLATE VOLTAGE	-	5500 VOLTS
DC PLATE CURRENT	-	2.0 AMPS
PLATE DISSIPATION	-	1670 VOLTS
GRID DISSIPATION	-	150 WATTS

**TYPICAL OPERATION (Frequencies below 30 MHz)**

DC Plate Voltage	-	-	-	4000	4500	5000	volts
DC Plate Current	-	-	-	1.67	1.47	1.25	amps
DC Grid Voltage	-	-	-	-450	-500	-550	volts
DC Grid Current*	-	-	-	180	140	150	ma
Peak RF Grid Input Voltage*	-	-	-	685	715	760	volts
Driving Power*	-	-	-	125	100	115	watts
Grid Dissipation*	-	-	-	43	30	32	watts
Plate Input Power	-	-	-	6670	6615	6250	watts
Plate Dissipation	-	-	-	1670	1315	950	watts
Plate Output Power	-	-	-	5000	5300	5300	watts

\*Approximate values.

**AUDIO-FREQUENCY POWER AMPLIFIER OR MODULATOR**  
 Class-AB or B

**MAXIMUM RATINGS**

DC PLATE VOLTAGE	-	6000 VOLTS
DC PLATE CURRENT	-	2.5 AMPS
PLATE DISSIPATION	-	2500 WATTS
GRID DISSIPATION	-	150 WATTS

**TYPICAL OPERATION (Sinusoidal wave, two tubes unless noted)**

DC Plate Voltage	-	-	-	4000	5000	6000	volts
DC Grid Voltage <sup>1</sup>	-	-	-	-150	-190	-240	volts
Zero-Signal DC Plate Current	-	-	-	0.6	0.5	0.4	amps
Max-Signal DC Plate Current	-	-	-	4.0	3.2	3.0	amps
Effective Load, Plate to Plate	-	-	-	2200	3600	4650	ohms
Peak AF Grid Input Voltage (per tube)*	-	-	-	340	360	390	volts
Max-Signal Peak Driving Power*	-	-	-	340	230	225	watts
Max-Signal Nominal Driving Power*	-	-	-	170	115	113	watts
Max-Signal Plate Output Power	-	-	-	11,000	11,000	13,000	watts

\*Approximate values.

<sup>1</sup>Adjust to give listed zero-signal plate current.

IF IT IS DESIRED TO OPERATE THIS TUBE UNDER CONDITIONS WIDELY DIFFERENT FROM THOSE GIVEN UNDER "TYPICAL OPERATION," POSSIBLY EXCEEDING THE MAXIMUM RATINGS GIVEN FOR CW SERVICE, WRITE EIMAC DIVISION OF VARIAN, FOR INFORMATION AND RECOMMENDATIONS.

**APPLICATION**

**Cooling**—Forced-air cooling must be provided to hold the ceramic-to-metal seals and anode core temperature below the maximum rating of 250°C. At ambient temperatures above 50 C, at higher altitudes and at operating temperatures above 30 MHz, additional air flow must be provided. Sea level and 10,000 foot altitude air-flow requirements to maintain seal temperatures below 200°C in 50 C ambient air are tabulated below ( for operation below 30 MHz).

Anode-to-Base Air Flow <sup>1</sup>				
Sea Level			10,000 Feet	
Anode Dissipation Watts	Air Flow CFM	Pressure Drop Inches Water	Air Flow CFM	Pressure Drop Inches Water
1500	33	.6	48	.9
2500	66	1.25	96	1.82

Base-to-Anode Air Flow				
Sea Level			10,000 Feet	
Anode Dissipation Watts	Air Flow CFM	Pressure Drop Inches Water	Air Flow CFM	Pressure Drop Inches Water
1500	32	.6	47	.9
2500	57	1.0	83	1.5

<sup>1</sup>Since the power dissipated by the filament represents about 400 watts and since grid dissipation can, under some conditions represent another 150 watts, allowance has been made in preparing this tabulation for an additional 550 watts.

<sup>2</sup>When air is supplied in the anode-to-base direction, a minimum of 3 cfm must be directed into the filament-stem structure between the inner and outer filament terminals to maintain the base seals below 250°C. No separate air is required with base-to-anode airflow.

**Filament Voltage** — The filament voltage, as measured directly at the tube, should be 7.5 volts with maximum allowable variations due to line fluctuation of from 7.12 to 7.87 volts. Tube life may be extended by operation at the lower end of this range.

**Bias Voltage** — There is little advantage in using bias voltages in excess of those given under "TYPICAL OPERATION" except in certain very specialized applications. Where bias is obtained from a grid resistor, suitable protective means must be provided to prevent excessive plate dissipation in the event of loss of excitation.

**Plate Voltage** — The plate-supply voltage for the 3CX2500F3 should not exceed 6000 volts. In most cases there is little advantage in using plate-supply voltages higher than those given under "TYPICAL OPERATION" for the power output desired.

**Grid Dissipation** — The power dissipated by the grid of the 3CX2500F3 must never exceed 150 watts. Grid dissipation is the product of dc current and peak positive grid voltage.

In equipment in which the plate loading varies widely, such as oscillators used for radio-frequency heating, care should be taken to make certain that the grid dissipation does not exceed the maximum rating under any condition of loading. With lightly loaded conditions the grid driving power should be reduced so that the grid current does not exceed one-tenth of the plate current.

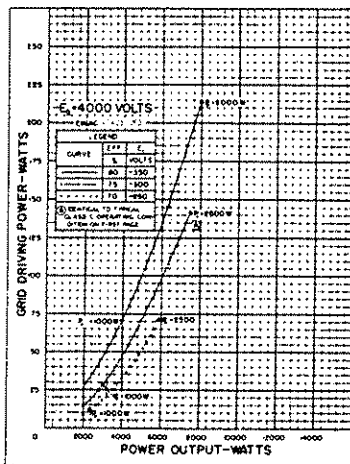
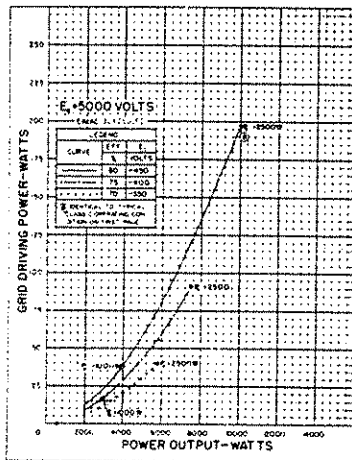
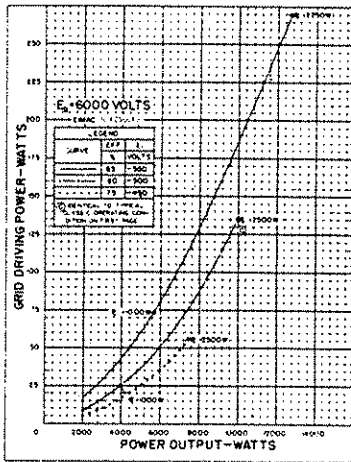

DIMENSIONAL DATA			
REF.	MIN.	MAX.	NOM.
A	4 1/32	4 5/32	
B	25/32	27/32	
C		3 8/8	
D	6.375	6.625	
E	.050	.090	
F	.812	.937	
G	11/16	13/16	
H	7.000	7.600	
K	3/8	7/16	
L		1 1/8	
M	7.000	7.600	
N	1 3/8	1 5/8	
P	7.937	8.437	
Q	5 7/8	4 1/4	
R			
S	1 3/16	1 11/16	
T	6	9	
U	6.937	8.437	

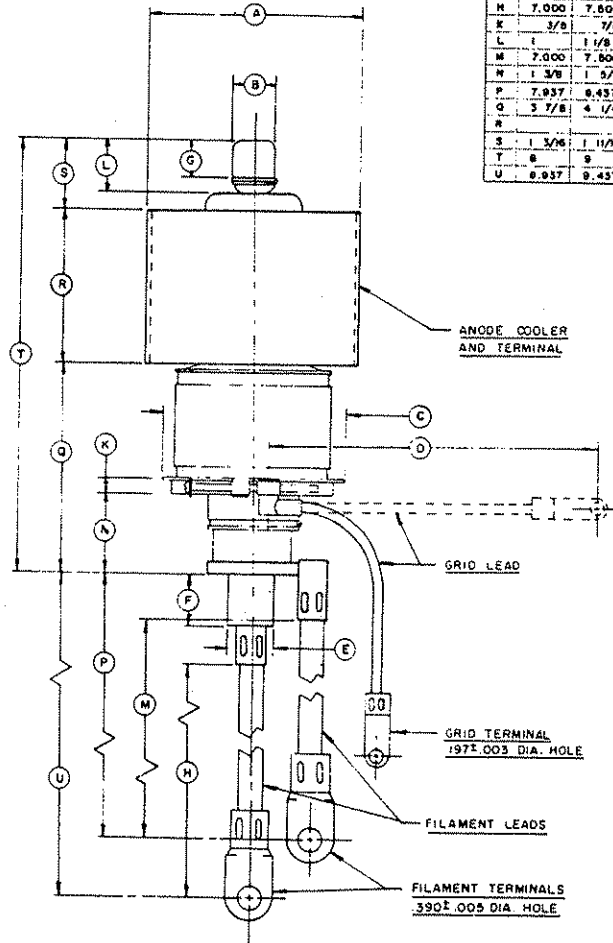

**DRIVING POWER vs. POWER OUTPUT**

The three charts on this page show the relationship of plate efficiency, power output and approximate grid driving power at plate voltages of 4000, 5000 and 6000 volts. These charts show combined grid and bias losses only. The driving-power and power-output figures do not include circuit losses. The plate dissipation in watts is indicated by P<sub>p</sub>. Points A, B, and C are identical to the typical Class C operating conditions shown on the first page under 4,000, 5000 and 6000 volts respectively.



3CX2500F3

EIMAC 3CX2500F3  
 CONSTANT CURRENT  
 CHARACTERISTICS

— PLATE CURRENT — AMPERES  
 ..... GRID CURRENT — AMPERES

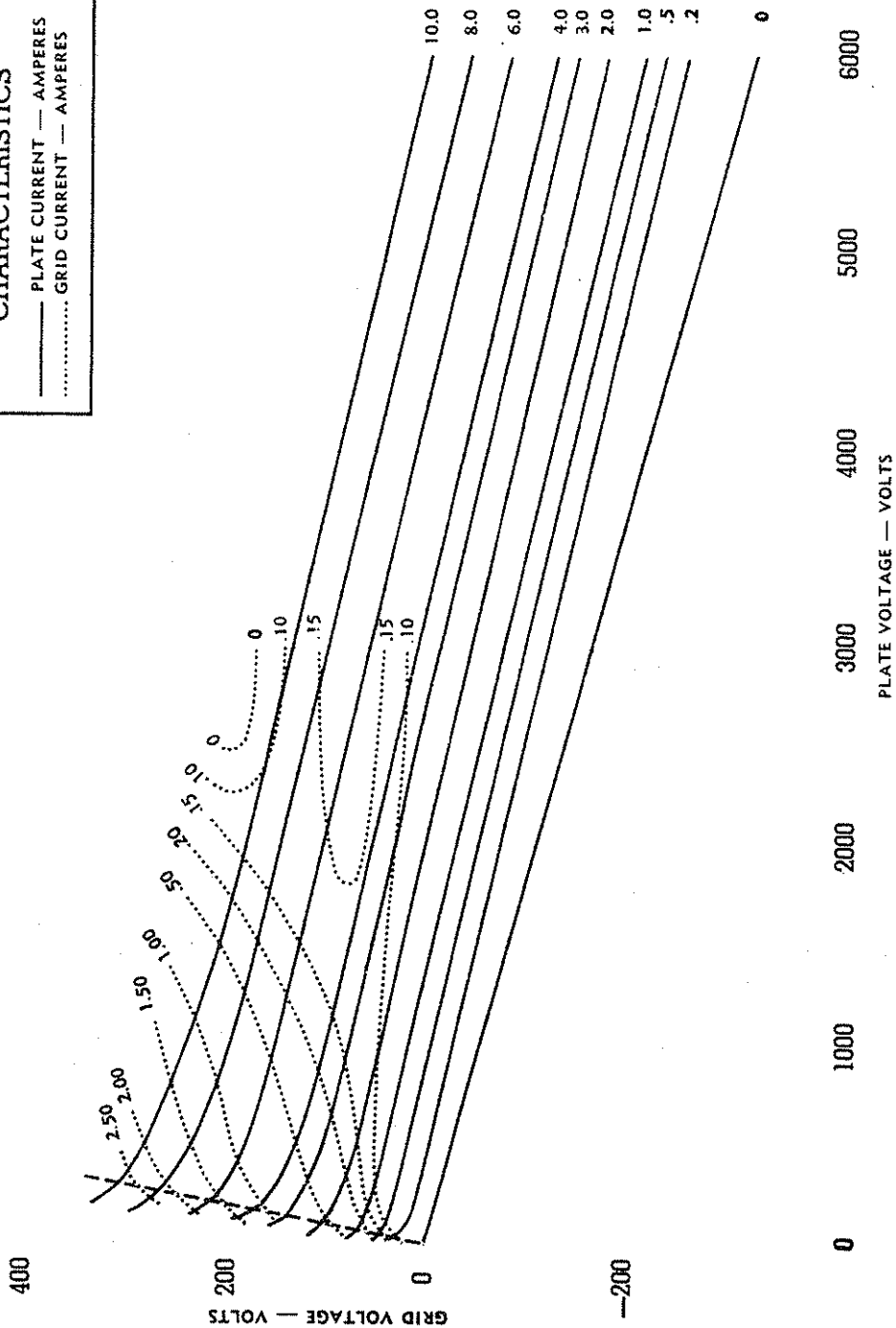

4

A-6

888-2109-010

If You Didn't Get This From My Site,  
Then It Was Stolen From...

www.SteamPoweredRadio.Com WARNING: Disconnect primary power prior to servicing



TECHNICAL DATA

8169  
4CX3000A  
RADIAL-BEAM  
POWER TETRODE

The EIMAC 8169/4CX3000A is a ceramic/metal power tetrode designed to be used as a Class AB<sub>1</sub> linear amplifier in audio or radio-frequency applications. Its low intermodulation distortion characteristics make it especially suitable for single-sideband service, where it will produce a minimum power output of 5000 watts in Class AB<sub>1</sub> service with intermodulation distortion at least 32 dB down for 3rd order products and 37 dB down for 5th order products.

The tube is also recommended for use as a Class C rf power amplifier and plate-modulated rf power amplifier. It is forced-air cooled, with a maximum anode dissipation rating of 3500 watts.

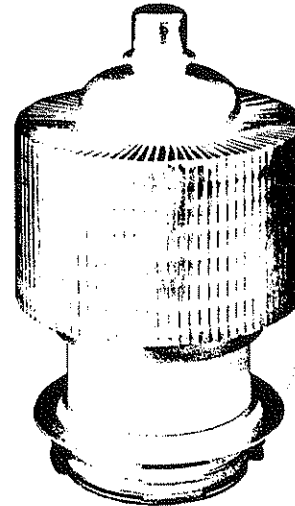

GENERAL CHARACTERISTICS<sup>1</sup>

ELECTRICAL

Filament: Thoriated Tungsten

Voltage .....	9.0 ± 0.45 V	
Current (at 9.0 volts) .....	41.5 A	
Amplification Factor (grid to screen) .....	5.5	
Frequency for Maximum Ratings (CW) .....		150 MHz
Direct Interelectrode Capacitance (grounded cathode) <sup>2</sup>		
Cin .....		130 pF
Cout .....		12.5 pF
Cgp .....		1.2 pF
Direct Interelectrode Capacitance (grounded grid) <sup>2</sup>		
Cin .....		61 pF
Cout .....		12.5 pF
Cpk .....		0.15 pF

1. Characteristics and operating values are based upon performance tests. These figures may change without notice as the result of additional data or product refinement. EIMAC Division of Varian should be consulted before using this information for final equipment design.
2. Capacitance values are for a cold tube as measured in a special shielded fixture in accordance with Electronic Industries Association Standard RS-191.

MECHANICAL

Base ..... Special ring and breechblock terminal surfaces

(Revised 1-20-76) © 1965, 1967, 1969, 1976 by Varian

Printed in U.S.A.

EIMAC division of varian / 301 industrial way / san carlos / california 94070

888-2109-010

A-7



8169/4CX3000A

Maximum Operating Temperature:  
 Ceramic Metal Seals and Anode Core ..... 250°C  
 Recommended Air System Socket ..... EIMAC SK-1400 series  
 Recommended Air Chimney ..... EIMAC SK-1406  
 Operating Position ..... Axis vertical, base up or down  
 Maximum Overall Dimensions:  
 Length ..... 7.90 In; 20.07 cm  
 Diameter ..... 4.62 In; 11.73 cm  
 Cooling ..... Forced Air  
 Net Weight ..... 5.5 lb; 2.5 kg

**RADIO-FREQUENCY POWER AMPLIFIER OR OSCILLATOR**

Class-C Telephony or FM  
 (Key-down conditions)

**ABSOLUTE MAXIMUM RATINGS:**

DC PLATE VOLTAGE ..... 7000 VOLTS  
 DC SCREEN VOLTAGE ..... 1000 VOLTS  
 DC PLATE CURRENT ..... 2.0 AMPERES  
 PLATE DISSIPATION ..... 3000 WATTS  
 SCREEN DISSIPATION ..... 175 WATTS  
 GRID DISSIPATION ..... 50 WATTS

**TYPICAL OPERATION**

Plate Voltage ..... 5000 7000 Vdc  
 Screen Voltage ..... 500 500 Vdc  
 Grid Voltage ..... -280 -300 Vdc  
 Plate Current ..... 1.9 1.9 Adc  
 Screen Current<sup>1</sup> ..... 250 230 mAdc  
 Grid Current<sup>1</sup> ..... 100 100 mAdc  
 Peak RF Grid Voltage<sup>1</sup> ..... 385 405 v  
 Driving Power<sup>1</sup> ..... 39 41 W  
 Plate Dissipation ..... 1900 2300 W  
 Plate Output Power ..... 7600 11,000 W

1. Approximate value.

**PLATE-MODULATED RADIO-FREQUENCY POWER AMPLIFIER**

Class-C Telephony (Carrier Conditions unless noted)

**ABSOLUTE MAXIMUM RATINGS:**

DC PLATE VOLTAGE ..... 5000 VOLTS  
 DC SCREEN VOLTAGE ..... 600 VOLTS  
 DC PLATE CURRENT ..... 1.4 AMPERES  
 PLATE DISSIPATION<sup>2</sup> ..... 2000 WATTS  
 SCREEN DISSIPATION ..... 175 WATTS  
 GRID DISSIPATION ..... 50 WATTS

1. Approximate value.  
 2. Corresponds to 3000 watts at 100% sine-wave mod.

**TYPICAL OPERATION**

Plate Voltage ..... 5000 Vdc  
 Screen Voltage ..... 500 Vdc  
 Peak AF Screen Voltage  
 (For 100% Modulation)<sup>1</sup> ..... 415 v  
 Grid Voltage ..... -375 Vdc  
 Plate Current ..... 1.4 Adc  
 Screen Current<sup>1</sup> ..... 170 mAdc  
 Grid Current<sup>1</sup> ..... 68 mAdc  
 Peak RF Grid Voltage<sup>1</sup> ..... 455 v  
 Grid Driving Power<sup>1</sup> ..... 31 W  
 Plate Dissipation ..... 1250 W  
 Plate Output Power ..... 5750 W

**AUDIO-FREQUENCY AMPLIFIER OR MODULATOR**

Class-AB

**ABSOLUTE MAXIMUM RATINGS (Per Tube)**

DC PLATE VOLTAGE ..... 6000 VOLTS  
 DC SCREEN VOLTAGE ..... 1000 VOLTS  
 DC PLATE CURRENT ..... 2.0 AMPERES  
 PLATE DISSIPATION ..... 3500 WATTS  
 SCREEN DISSIPATION ..... 175 WATTS  
 GRID DISSIPATION ..... 50 WATTS

1. Per Tube.  
 2. Approximate values.

**TYPICAL OPERATION (Two Tubes), Class AB<sub>1</sub>**

Plate Voltage ..... 5000 6000 Vdc  
 Screen Voltage ..... 850 850 Vdc  
 Grid Voltage<sup>1</sup> ..... -180 -200 Vdc  
 Max-Signal Plate Current ..... 3.6 3.1 Adc  
 Zero-Signal Plate Current ..... 1.0 0.7 Adc  
 Max-Signal Screen Current<sup>2</sup> ..... 170 120 mAdc  
 Zero-Signal Screen Current<sup>2</sup> ..... 0 0 mAdc  
 Peak AF Driving Voltage<sup>1,2</sup> ..... 155 175 v  
 Driving Power ..... 0 0 W  
 Load Resistance, Plate-to-Plate ..... 3000 4160 Ω  
 Max-Signal Plate Dissipation<sup>1</sup> ..... 3300 3100 W  
 Max-Signal Plate Output Power ..... 11,400 12,400 W

**RADIO-FREQUENCY LINEAR AMPLIFIER**  
 Class AB

**ABSOLUTE MAXIMUM RATINGS:**

DC PLATE VOLTAGE	7000 VOLTS
DC SCREEN VOLTAGE	1000 VOLTS
DC PLATE CURRENT	2.0 AMPERES
PLATE DISSIPATION	3500 WATTS
SCREEN DISSIPATION	175 WATTS
GRID DISSIPATION	50 WATTS

1. Approximate values.

**TYPICAL OPERATION Class AB<sub>1</sub>, Grid Driven**

Plate Voltage	5000 Vdc
Screen Voltage	850 Vdc
Grid Voltage	-180 Vdc
Zero-Signal Plate Current	0.5 Adc
Single-Tone Plate Current	1.65 Adc
Single-Tone Screen Current <sup>1</sup>	25 mAdc
Two-Tone Plate Current <sup>1</sup>	1.10 Adc
Two-Tone Screen Current <sup>1</sup>	20 mAdc
Peak RF Grid Voltage <sup>1</sup>	155 v
Driving Power	0 W
Peak Envelope Useful Output Power <sup>1</sup>	5300 W
Intermodulation Distortion Products (without negative feedback) 3rd Order	-35 dB
5th Order	-40 dB

NOTE: TYPICAL OPERATION data are obtained from direct measurement or by calculation from published characteristic curves. Adjustment of the rf grid voltage to obtain the specified plate current at the specified bias, screen and plate voltages is assumed. If this procedure is followed, there will be little variation in output power when the tube is changed, even though there may be some variation in grid and screen current. The grid and screen currents which result when the desired plate current is obtained are incidental and vary from tube to tube. These current variations cause no difficulty so long as the circuit maintains the correct voltage in the presence of the variations in current. In the case of Class C Service, if grid bias is obtained principally by means of a grid resistor, the resistor must be adjustable to obtain the required bias voltage when the correct rf grid voltage is applied.

**RANGE VALUES FOR EQUIPMENT DESIGN**

	Min.	Max.
Filament Current, at 9:0 volts	39.5	43.5 A
Interelectrode Capacitance (grounded cathode) <sup>1</sup>		
C <sub>in</sub>	120	140 pF
C <sub>out</sub>	10.5	14.5 pF
C <sub>gp</sub>	---	1.40 pF
Interelectrode Capacitance (grounded grid) <sup>1</sup>		
C <sub>in</sub>	55.0	67.0 pF
C <sub>out</sub>	10.5	14.5 pF
C <sub>pk</sub>	---	0.20 pF
Grid Voltage (E <sub>b</sub> = 2000 Vdc; E <sub>c2</sub> = 750 Vdc; adjust for I <sub>b</sub> = 1000 mAdc)	-95	-127 Vdc
Grid Cut off Voltage (E <sub>b</sub> = 4000 Vdc; E <sub>c2</sub> = 850 Vdc; adjust for I <sub>b</sub> = 1.0 mAdc)	---	-310 Vdc

1. Capacitance values are for a cold tube as measured in a special shielded fixture in accordance with Electronic Industries Association Standard RS-191.

**APPLICATION**
**MECHANICAL**

**MOUNTING** - The 4CX3000A must be operated with its axis vertical. The base of the tube may be down or up at the convenience of the circuit designer.

**SOCKETING** - The EIMAC sockets, type SK-1400A and SK-1470A, have been designed especially for the base of the 4CX3000A. The SK-1400A has no contacts grounded to the socket shell and has an integral screen grid bypass capacitor of 1800 pF, with a 1000 DCWV rating.



8169/4CX3000A

The SK-1470A has no bypass capacitor and the screen grid contacts are directly grounded to the socket shell.

The use of recommended air-flow rates through these sockets provides effective forced-air cooling of the tube. Air forced into the bottom of the socket passes over the tube terminals through the Air Chimney SK-1406, and through the anode cooling fins.

**COOLING** - The maximum temperature rating for the external surfaces of the 4CX3000A is 250°C. Sufficient forced-air circulation must be provided to keep the temperature of the anode at the base of the cooling fins and the temperature of the ceramic/metal seals below 250°C. Air-flow requirements to maintain seal temperature at 200°C in 40°C ambient air are tabulated below (for operation below 30 megahertz).

Plate Dissipation* (Watts)	SEA LEVEL		10,000 FEET	
	Air Flow (CFM)	Pressure Drop (In. of Water)	Air Flow (CFM)	Pressure Drop (In. of Water)
1500	36.5	0.3	53	0.4
2500	60	0.8	88	1.2
3500	86	1.6	125	2.3

\* Since the power dissipated by the filament represents about 450 watts and since grid-plus-screen dissipation can, under some conditions, represent another 225 watts, allowance has been made in preparing this tabulation for an additional 675 watts dissipation.

The blower selected in a given application must be capable of supplying the desired air flow at a back pressure equal to the pressure drop shown above plus any drop encountered in ducts and filters.

*At other altitudes and ambient temperatures the flow rate must be modified to obtain equivalent cooling.* The flow rate and corresponding pressure differential must be determined individually in such cases, using rated maximum temperatures as the criteria for satisfactory cooling.

#### ELECTRICAL

**FILAMENT OPERATION** - The peak emission at rated filament voltage of the EIMAC 4CX3000A is normally many times the peak emission required for communication service. A small decrease in filament temperature due to reduction of filament voltage can increase the life of

the 4CX3000A by a substantial percentage. It is good practice to determine the nominal filament voltage for a particular application that will not affect the operation of the equipment. This is done by measuring some important parameter of performance such as plate current, power output, or distortion while filament voltage is reduced on the 4CX3000A. At some point in filament voltage there will be a noticeable reduction in plate current, or power output, or an increase in distortion. Operation may be at a filament voltage slightly higher than that point at which performance appears to deteriorate. This voltage should be measured at the socket with a 1% meter and periodically checked to maintain proper operation.

**GRID OPERATION** - The 4CX3000A grid has a maximum dissipation rating of 50 watts. Precautions should be observed to avoid exceeding this rating. The grid bias and driving power should be kept near the values shown in the "Typical Operation" sections of the data sheet whenever possible. The maximum grid circuit resistance should not exceed 100,000 ohms per tube.

**SCREEN OPERATION** - The power dissipated by the screen of the 4CX3000A must not exceed 175 watts.

Screen dissipation, in cases where there is no ac applied to the screen, is the simple product of the screen voltage and the screen current. If the screen voltage is modulated, the screen dissipation will depend upon loading, driving power, and carrier screen voltage.

Screen dissipation is likely to rise to excessive values when the plate voltage, bias voltage, or plate load are removed with filament and screen voltages applied. Suitable protective means must be provided to limit the screen dissipation to 175 watts in the event of circuit failure.

**PLATE DISSIPATION** - The plate-dissipation rating for the 4CX3000A is 3500 watts. When it is operated as a plate-modulated rf amplifier, under carrier conditions, the maximum plate dissipation is 2000 watts.

**FAULT PROTECTION** - In addition to normal cooling airflow interlock and plate and screen over-current interlocks, it is good practice to protect the tube from internal damage which could result from occasional plate arcing at high plate voltage.





In all cases some protective resistance, at least one or two ohms, should be used in series with the tube anode to absorb power supply stored energy in case a plate arc should occur. Where stored energy is high, it is recommended that some form of electronic crowbar be used which will discharge power supply capacitors in as short a time as possible following indication of start of a plate arc.

**HIGH VOLTAGE** - Normal operating voltages used with the 4CX3000A are deadly, and the equipment must be designed properly and operating precautions must be followed. Design all equipment so that no one can come in contact with high voltages. All equipment must include safety enclosures for high-voltage circuits and terminals, with interlock switches to open primary circuits of the power supply and to discharge high-voltage condensers whenever access doors are opened. Interlock switches must not be bypassed or "cheated" to allow operation with access doors open. Always remember that HIGH VOLTAGE CAN KILL.

**INTERELECTRODE CAPACITANCE** - The actual internal interelectrode capacitance of a tube is influenced by many variables in most applications, such as stray capacitance to the chassis, capacitance added by the socket used, stray capacitance between tube terminals, and

wiring effects. To control the actual capacitance values within the tube, as the key component involved, the industry and the Military Services use a standard test procedure as described in Electronic Industries Association Standard RS-191. This requires the use of specially constructed test fixtures which effectively shield all external tube leads from each other and eliminates any capacitance reading to "ground". The test is performed on a cold tube. Other factors being equal, controlling internal tube capacitance in this way normally assures good interchangeability of tubes over a period of time, even when the tube may be made by different manufacturers. The capacitance values shown in the manufacturer's technical data, or test specifications, normally are taken in accordance with Standard RS-191.

The equipment designer is therefore cautioned to make allowance for the actual capacitance values which will exist in any normal application. Measurements should be taken with the socket and mounting which represent approximate final layout if capacitance values are highly significant in the design.

**SPECIAL APPLICATIONS** - If it is desired to operate this tube under conditions widely different from those given here, write to Power Grid Tube Product Manager, EIMAC Division of Varian, 301 Industrial Way, San Carlos, California 94070 for information and recommendations.



8169/4CX3000A

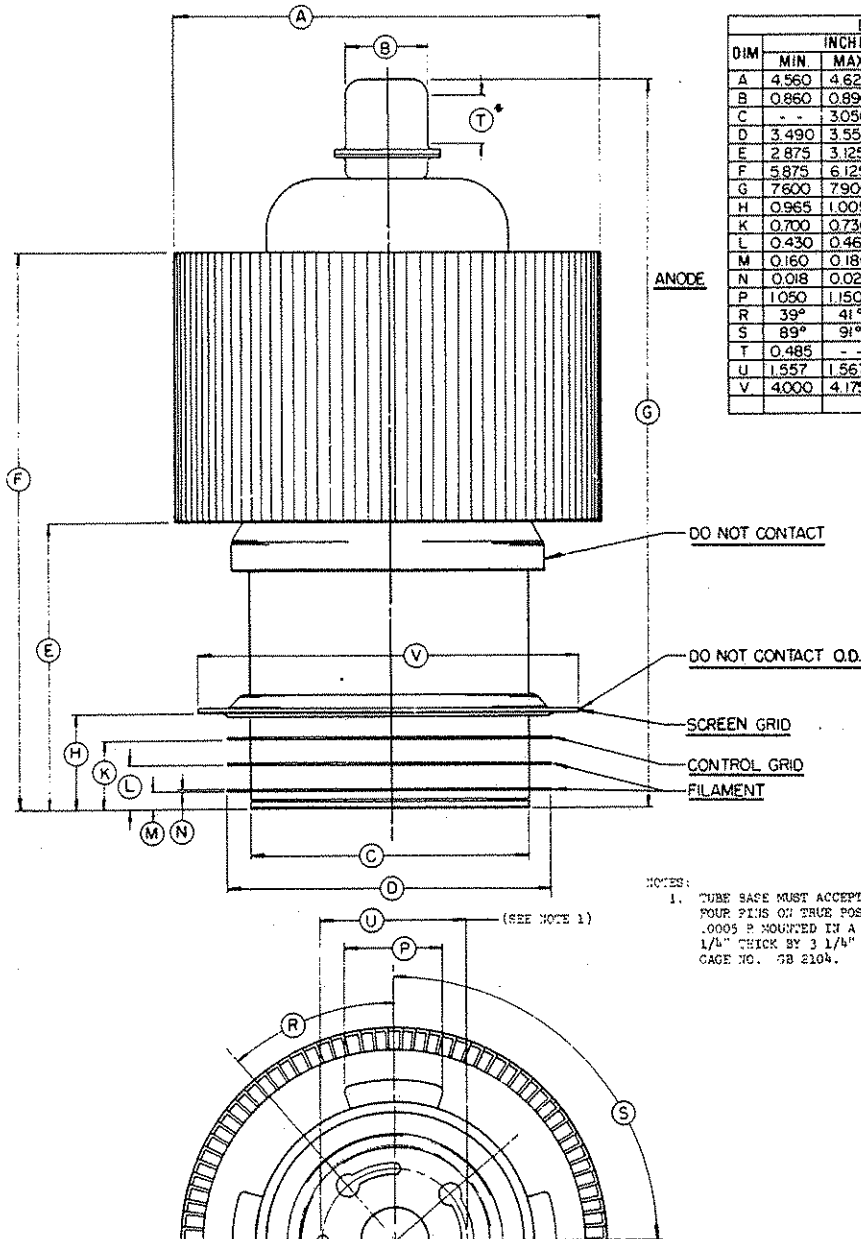

DIM	INCHES			MILLIMETERS		
	MIN	MAX	REF.	MIN	MAX	REF.
A	4.560	4.625	- -	115.82	117.48	- -
B	0.860	0.890	- -	21.84	22.61	- -
C	- -	3.050	- -	- -	77.44	- -
D	3.490	3.550	- -	88.65	90.17	- -
E	2.875	3.125	- -	73.03	79.38	- -
F	5.875	6.125	- -	149.23	155.58	- -
G	7.600	7.900	- -	193.04	200.66	- -
H	0.965	1.005	- -	24.51	25.53	- -
K	0.700	0.730	- -	17.78	18.54	- -
L	0.430	0.460	- -	10.92	11.68	- -
M	0.160	0.180	- -	4.06	4.57	- -
N	0.018	0.025	- -	0.46	0.64	- -
P	1.050	1.150	- -	26.67	29.21	- -
R	39°	41°	- -	39°	41°	- -
S	89°	91°	- -	89°	91°	- -
T	0.485	- -	- -	12.32	- -	- -
U	1.557	1.567	- -	39.55	39.80	- -
V	4.000	4.175	- -	101.60	106.05	- -

NOTES:  
 1. TUBE FACE MUST ACCEPT A GAGE WITH FOUR PINS ON TRUE POSITION WITHIN .0005 P MOUNTED IN A BASE PLATE 1/4" THICK BY 3 1/4" DIA. EIMAC CAGE NO. 38 2104.



**EIMAC 4CX3000A  
IM DISTORTION VS.  
POWER OUTPUT**

(As function of zero-signal  
plate current)

$E_b = 5000$  Volts,  $E_{c2} = 850$  Volts

$R_L = 1700$  Ohms,  $F_1 = 1.980$  MHz

$F_2 = 1.982$  MHz

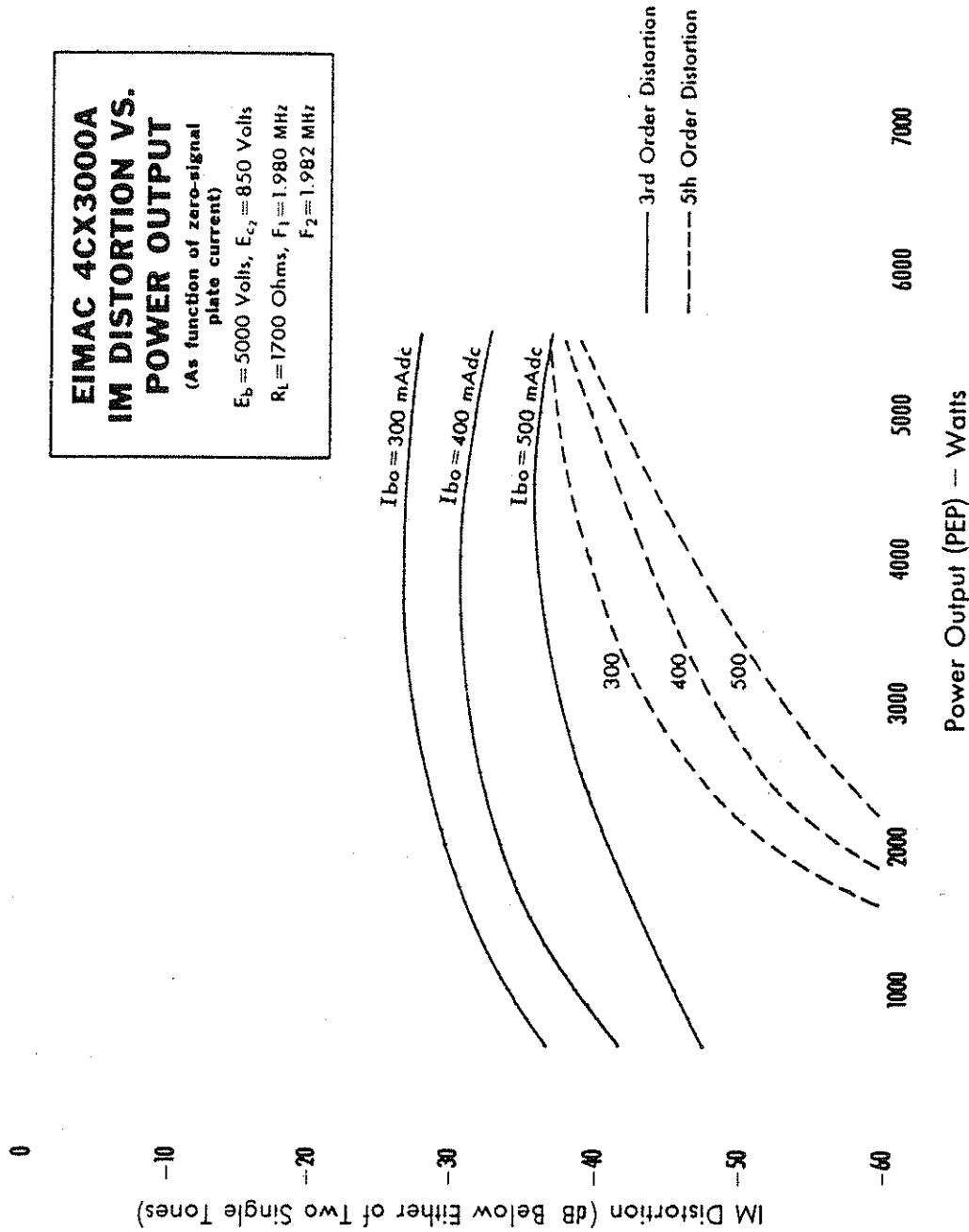



**EIMAC 4CX3000A**  
**TYPICAL CONSTANT**  
**CURRENT**  
**CHARACTERISTICS**  
 SCREEN VOLTAGE = 500 VOLTS  
 ——— PLATE CURRENT — AMPERES  
 - - - SCREEN CURRENT — AMPERES  
 - - - - GRID CURRENT — AMPERES

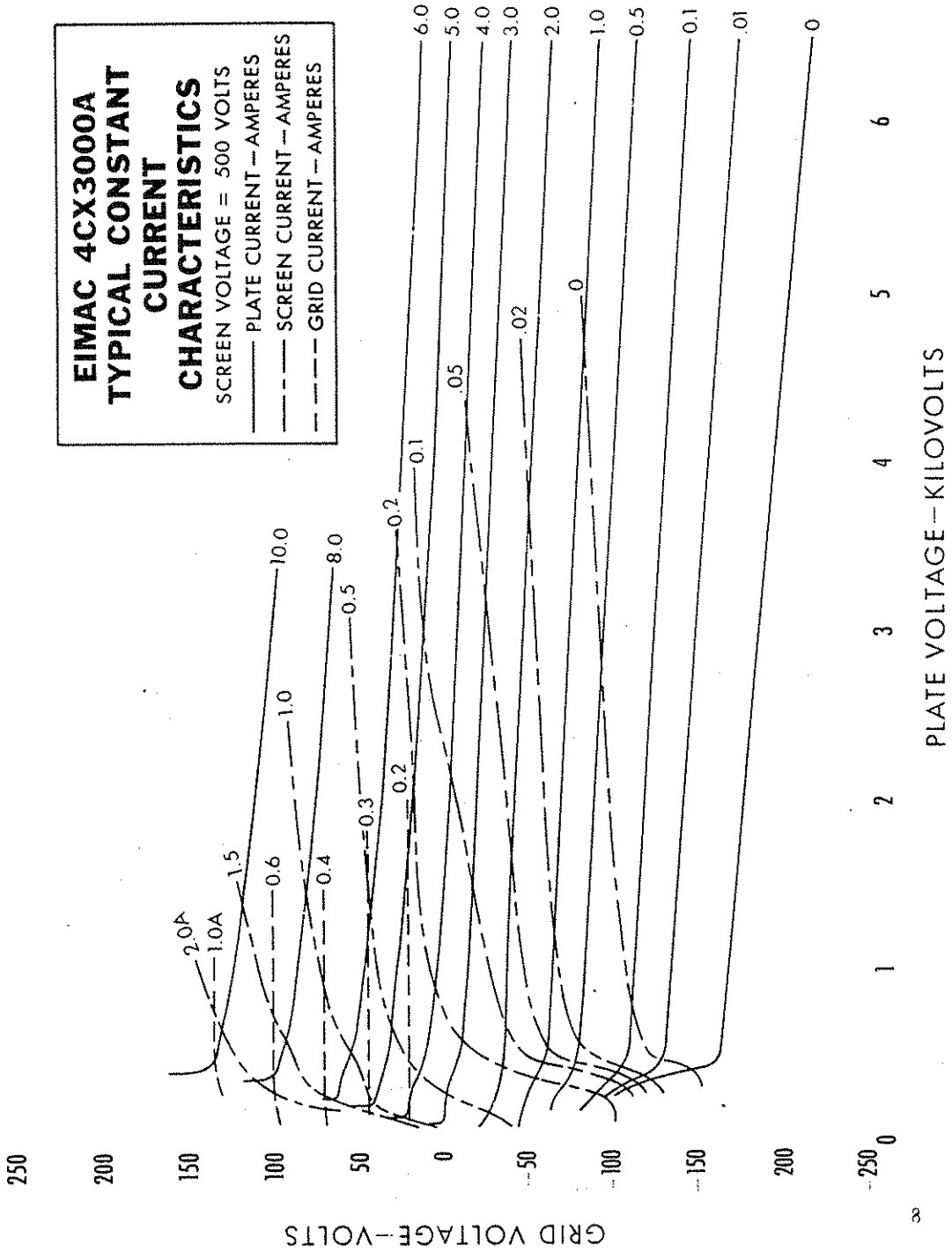



8169/4CX3000A

**EIMAC 4CX3000A**  
**TYPICAL CONSTANT**  
**CURRENT**  
**CHARACTERISTICS**  
 SCREEN VOLTAGE = 850 VOLTS

— PLATE CURRENT — AMPERES  
 - - - SCREEN CURRENT — AMPERES  
 - - - GRID CURRENT — AMPERES

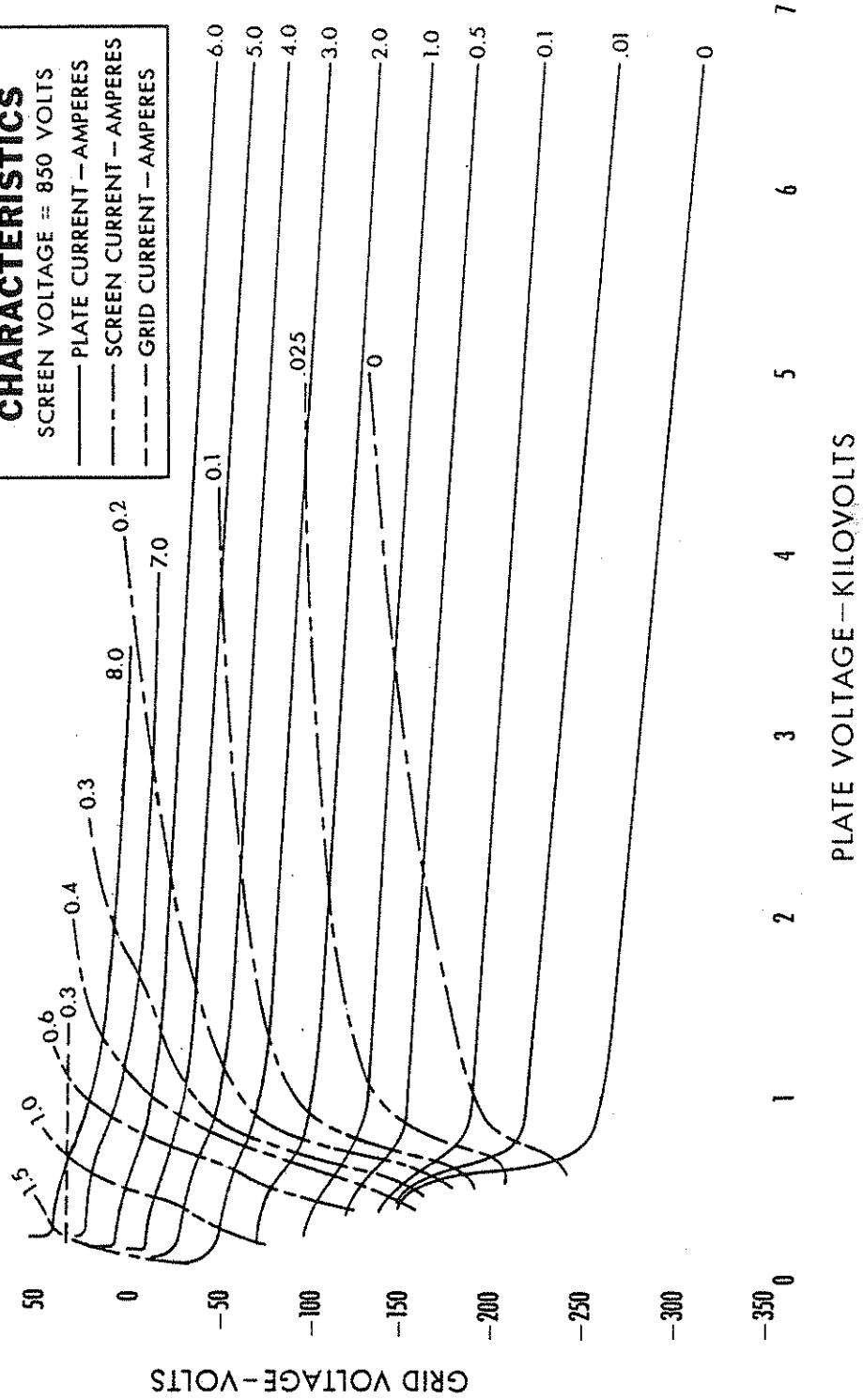

6

888-2109-010

A-15/A-16



## engineering newsletter

### LIFE VS. FILAMENT VOLTAGE

#### TUBE TYPES WITH THORIATED-TUNGSTEN FILAMENTS OR CATHODES.

Power tube users and equipment manufacturers are naturally interested in extending the life of these tubes. A very large factor in tube life is the temperature of the thoriated-tungsten cathode.

The equipment manufacturer and the end user of the equipment have more control over tube life through proper adjustment of filament voltage (filament power) than is generally realized. This is true because tube ratings and most equipment designs are conservative in peak cathode emission required of the tube compared with peak cathode emission available at nominal rated filament voltage.

It is good practice to determine in the field for each particular combination of equipment and operating power level, the nominal filament voltage for best life. This is best done in the field by measuring some important parameter of performance such as plate current, power output, or distortion while filament voltage on the power tube is reduced. At some point in filament voltage there will be a noticeable reduction in plate current, or power output, or an increase in distortion. Operation may safely be at a filament voltage slightly higher than that point at which performance appeared to deteriorate. A recheck should be made in 12 to 24 hours to make certain that emission is stable.

The thoriated-tungsten filament or cathode is processed in a hydro-carbon atmosphere to form a deep layer of di-tungsten carbide on the surface. Stable emission is not possible without the carbide. If the carbide layer is too deep the filament becomes too brittle to withstand shipping and handling. The end of useful life for this type of filament occurs when most of the carbon has evaporated or combined with residual gas, depleting the carbide surface layer.

Theoretically it is estimated that a 3% increase in filament voltage will result in a 20°K increase in temperature, a 20% increase in peak emission, and a 50% decrease in life due to carbon loss. This, of course, works the other way, too. For a small decrease in temperature and peak emission, life of the carbide layer and hence tube life can be increased by a substantial percentage. Peak emission as meant here is the emission obtained in the test for emission described in the Test Specification. This is normally many times the peak emission required in communication service.

ENL-12

Continued.....

*an application engineering service - eimac, division of varian*

Obviously, if small percentage variations in filament voltage are to have a large percentage effect on tube life, it is important to be able to measure and adjust filament voltage measured at the tube terminals with accuracy of about 1%.

The common rectifier type of multimeter which is used for almost every measurement in electronic gear, should not be relied on for AC filament voltage measurement. A simple iron-vane AC meter which has recently been checked against a reliable standard is the best inexpensive instrument for this measurement because it responds to the RMS, or heating value, of the voltage wave form.

As a guide for use with most communications, and broadcast equipment, to get the best life service from your EIMAC power tubes, the following table has been prepared. It is not meant to imply that lower filament voltage will not be satisfactory in some instances.

SUGGESTED NOMINAL FILAMENT VOLTAGE

FOR

EXTENDED LIFE IN BROADCAST AND COMMUNICATION SERVICE

TUBE TYPE

3X2500A3 and F3	7.2 volts
3X3000A1 and A7	7.2
3CX2500A3 and F3	7.2
3CX3000A1 and A7	7.2
3CX10,000A3, A1 and A7	7.2
3CX15,000A3	6.0
6697A	12.3
4-125A	4.8
4-400A	4.8
4-1000A	7.2
4W20,000A	(2300 watts cathode heating power)
4CX3000A	8.6 volts
4CX5000A	7.2
4CX10,000D	7.2
4CX15,000A	6.0
4CX35,000C	9.0
4CV100,000C	9.0
4E27A	4.8
5-500A	9.5
5CX1500A	4.8
5CX3000A	8.6

Credit is due the paper, High Power Transmitting Valves ---, by Walker, Aldous, Roach, Webb and Goodchild, IEE Paper No. 3200E March, 1960, also the paper Life Expectancy Tubes ---, Eitel-McCullough, October 6, 1963, by Paul Williams.

Page 2

WHM65D29  
MOD. 9-20-65

HARRIS ENGINEERING DEPARTMENT  
POWER DISTRIBUTION RECOMMENDATION

Radio and Television transmitters using three-phase power must operate with the line-to-line voltages well balanced. Operation with the incoming line-to-line voltages substantially unbalanced will increase the ripple from the three-phase power supplies, primarily at twice the power line frequency, and thus increase the hum of the transmitter. Unbalanced line voltages result in unbalanced currents in the windings of the three-phase transformers, and in unbalanced currents in the windings of three-phase motors.

Three-phase motors should be run with line voltage balance within 1%; a 3-1/2 percent line voltage unbalanced will produce a temperature rise approximately 25% above normal in the winding carrying the greater of the unbalanced currents, while a 5% unbalance will produce a temperature rise approximately 50% greater than normal.

The regulation of a three-phase open delta transformer bank is much poorer than that of a closed delta bank.<sup>(1)</sup> The closed delta bank is symmetrical; the open delta is not; so the regulation in each of the three phases differs widely, and the effect of this may be an appreciable line voltage unbalance. The regulation of a closed delta is symmetrical on each phase.

Depending upon the impedances of the two transformers making up the open delta this appreciable line voltage unbalance may be great enough to impair satisfactory operation of the transmitter. HARRIS customers have experienced this with open delta distribution, and when the third transformer was added for closed delta service, the problem disappeared.

Transient overvoltages with open delta distribution can cause transmitter damage, particularly to the silicon rectifiers used in the main HV power supply. This is sometimes troublesome when the open delta transformers are at the end of a long overhead open wire distribution system. Several HARRIS

---

1. "Transformer Engineering" - Blume, Boyajian, Camilli, Lennox, Minneci, & Montsinger (John Wiley & Sons). 2nd 1967.



customers, upon following the HARRIS recommendation and adding the third transformer, have found the difficulty gone.

Although the above argument specifically calls out Closed Delta distribution, a WYE distribution also uses three transformers, and is symmetric, avoiding the difficulties arising from the non-symmetrical configuration of the Open Delta distribution.

#### WYE TYPE POWER DISTRIBUTION

In large segments of the world the power distribution is four-wire WYE. Single phase service is derived between the neutral of the WYE distribution and any one of the three other wires.

Three-phase main power supply transformers for small transmitters - 10 kilowatts or less - in the United States are generally operated from three-phase lines in the 210 to 250 volt range, line to line. HARRIS has adopted the practice of specifying three-phase transformers for transmitters of this class with three separate primaries, each having appropriate taps to accommodate the several nominal voltages in this range. For service in the United States these primaries are connected in Delta.

For service in those parts of the world in which the power distribution is four-wire WYE in the 360 to 415-volt range these three primaries are connected in WYE, with each primary tapped for the line to neutral voltage. The neutral point of the three primaries of the transformer within the transmitter is solidly connected to the power distribution system neutral, to provide a path for zero sequence currents, as well as any harmonic currents which might flow due to the rectification of the secondary voltages.

The line-to-line voltage is equal to the line to neutral voltage multiplied by the square root of three (1.732 approximately), nominally.

Typical system voltages: (Nominal)

LINE TO NEUTRAL (single phase)

LINE TO LINE (three phase)

210 volts

364 volts

220 volts

380 volts

230 volts

400 volts

240 volts

415 volts

250 volts

433 volts

In summary, either a closed delta or WYE distribution system is satisfactory for HARRIS transmitter.