

# INSTRUCTION BOOK



M-6160

SUBCARRIER GENERATOR



<b>HARRIS</b>	<b>GATES</b>
<b>INTERTYPE</b>	
<b>CORPORATION</b>	

**GATES RADIO COMPANY**

A Subsidiary of Harris-Intertype Corporation

QUINCY, ILLINOIS, 62302

If You Didn't Get This From My Site,  
Then It Was Stolen From...

[www.SteamPoweredRadio.Com](http://www.SteamPoweredRadio.Com)

## **REPLACEMENT PARTS**

When ordering replacement parts please address your order to:

**GATES RADIO COMPANY**  
**Order Department**  
**Quincy, Illinois 62302**

The following information must be supplied if applicable:

- (1) Quantity required.
- (2) Gates Part Number—Ten digit I.B.M. or M number.
- (3) Item or Symbol Number from Instruction Book schematic or Parts List.
- (4) Type Number of equipment in which component is used.
- (5) Complete address for shipping and billing instructions.

## **RETURNS AND EXCHANGES**

Do not return any merchandise without our written approval and Return Authorization. We will provide special shipping labels and a code number that will assure proper handling and prompt issuance of credit. Please furnish a detailed report to assure prompt handling of returned merchandise. Custom built equipment or merchandise specially ordered for you is not returnable. Where return of standard equipment is allowed by Gates, a restocking fee of 15% will be charged. All returned merchandise must be sent freight prepaid and properly insured by the customer. When writing to Gates Radio Company about your order, it will be helpful if you specify the Gates Factory Order Number or Invoice Number.

## **MODIFICATIONS**

Gates reserves the right to modify the design and specifications of the equipment shown in this Instruction Book without notice or to withdraw any item from sale provided, however, that any modifications shall not adversely affect the performance of the equipment so modified.

INSTRUCTION BOOK  
994-6160-001 SUBCARRIER GENERATOR  
WITH AUTOMATIC MUTING

888-0798-001

Gates Radio Company  
Quincy, Illinois

ADDENDUM

994 6160 001 SUBCARRIER GENERATOR

WITH AUTOMATIC MUTING

In the 41 KC SCA units, the value of L3 has been increased from 25 MH to 50 MH. The Gates Stock Number is 494 0093 000 for the 50 MH choke. The new choke was installed to reduce the distortion of the 41 KC carrier frequency.

1/6/65

Gates Radio Company  
Quincy, Illinois

ADDENDUM SHEET

994 6160 001 SUBCARRIER GENERATOR

WITH AUTOMATIC MUTING

The M-6160 Subcarrier Generator is designed to function with the M-6146 Stereo Generator. The interconnecting power cable must be installed by the customer who is receiving each unit separately. The audio input leads are already installed in the Stereo Generator. The audio and power leads must be installed in the U.S. component connector (P2) which is furnished.

Method of assembly and proper connections are indicated on Assembly Instruction for connector, P2 which is included in this Instruction Book.

For additional information refer to:

Schematic 842 3509 001 (Stereo Generator, M6146)

Schematic 842 3644 001 (Subcarrier Generator, M6160)

3/8/63

Gates Radio Company  
Quincy, Illinois

ADDENDUM SHEET

994 6160 001 SUBCARRIER GENERATOR

WITH AUTOMATIC MUTING

1. When setting the frequency of the subcarrier generator, back cover should be on. If cover is removed later, the output frequency is apt to change.
  
2. If interference is experienced from a strong local AM broadcast station, it may be necessary to shift the frequency of the individual oscillators of the subcarrier generator to other than specified. For example: A strong local signal on 810 KC produces a beat note on the 67 KC subcarrier. Change the subcarrier oscillators to 723 and 790 KC or to 830 and 897 KC to obtain a "clean" 67 KC subcarrier.

6/20/62

Gates Radio Company  
Quincy, Illinois

INDEX

	Page
SPECIFICATIONS.....	1
FRONT PANEL CONTROLS.....	2
BRIEF DESCRIPTION.....	1 - 2
ADJUSTMENT AND SETTING UP PROCEDURES.....	3
AUDIO INPUT LEVELS.....	3
RESPONSE.....	4
MODULATION OF MAIN CARRIER BY SUBCARRIER.....	4 - 5
MUTING LEVELS AND TIME CONSTANTS.....	6 - 7
OPERATIONAL AND TECHNICAL ASPECTS.....	8 - 10
SUMMARY.....	11-12
ASSEMBLY INSTRUCTION FOR CONNECTOR P2 .....	13
FIELD INSTALLATION OF SUB-CARRIER GENERATOR ..	14
PARTS LIST .....	1 - 3
DRAWINGS:	
813 7663 001 - Response Curves	
826 8773 001 - Block Diagram	
826 8798 001 - Sideband Distribution	
826 8797 001 - Spectrum Distribution	
826 8796 001 - Spectrum Distribution	
937 9642 001 - Power Cable	
842 3644 001 - Schematic	
814 1678 001 - Sub-Carrier Generator Placement in Stereo Generators	

6/20/62

994 6160 001

SPECIFICATIONS - 994 6160 001 (M6160)

SUB CARRIER GENERATOR WITH AUTOMATIC MUTING

Frequency: Any, between 25 and 75 KC

Frequency Stability:  $\pm$  500 Cycles

Audio Input: 600 ohm impedance balanced, +10 dbm, +2 db. for  $\pm$ 5 KC deviation at 400 cycles.

Modulation Distortion:  $\pm$ 5 KC deviation - better than 1%  
(30-15,000 cycles)  $\pm$ 7.5 KC deviation - better than 1.5%  
 $\pm$ 10 KC deviation - better than 2.5%

Audio Response: Flat or 50 microsecond (modified)\*

FM Noise: -55 db. (reference  $\pm$ 5 KC at 400 cycles)

Amplitude Ripple: 5% or less  
(due to frequency deviation)

Output Level: 1.5 VPP. adjustable by front panel control.  
(into 100K ohm)

Power Requirements: 150 V.D.C. @ 5 MA.  
6.3 V.A.C. @ .75 A.

Tube Complement (3): 2 - 12AX7  
1 - 5725 (6AS6)

Automatic Mute Level: Variable from 0 to -40 db. by front panel control.

Weight: 1 lb., 7 oz. Complete

Dimensions: Front Panel, 7" x 4 1/8" rear cover,  
6" x 3 1/2" x 2 1/2" deep (designed to fit in panel slot of 6 1/4" x 3 3/8")

\* All generators normally supplied with modified 50 microsecond pre-emphasis ( 4 db roll-off at 15 KC) except 67 KC generator for use with FM Stereo shipped with flat response ( 4 db. roll-off at 15 KC).

6/20/62

-1-

994-6160-001



FRONT PANEL CONTROLS

L1 Adjusts frequency of oscillator  
number 1

L2 Adjusts frequency of oscillator  
number 2

Output  
(R17) Adjusts sub-carrier output level  
at J1

Mute  
(R39) Determines audio input level at which  
Sub-carrier will switch off.

S1 Function switch:  
Off - +150 removed from all stages  
S- Mute short time constant  
M- Mute medium time constant  
L- Mute long time constant  
ON- Sub-carrier continuous output  
at J1

6/20/62

-2-

994 6160 001

## SUBCARRIER GENERATOR

### Brief Description

When engaged in FM broadcasting the FCC allows transmission of supersonic signals in the region of from 25 to 75 KC for the purpose of subsidiary communications. Transmission of these supersonic signals is referred to as Multiplexing. Transmission of these multiplex, or supersonic, signals is then used for the purpose of background music in stores, restaurants and factories, or for the purpose of broadcasting weather and other information. Probable and possible future use of this type of transmission appears to be unlimited.

Gates method of producing multiplex signals in the 994-6160-001 Generator will be briefly explained at this point. Refer to block diagram and schematic.

Each section of V1 is a Colpitts oscillator. The first section of V1 oscillates at 800 KC. The second section of V1 oscillates above 800 KC by the difference of the subcarrier frequency.

Each of these signals may be frequency modulated by means of CR1, in V1A, and CR2 in V1B. These are special types of silicon diodes known as voltage variable capacitors.

These two signals are then mixed by means of silicon diodes CR3 and CR4. All but the difference or subcarrier frequency is eliminated by low pass filter, C13, C14 and L3.

This difference frequency is then connected to output control R17. This control may be set for any desired output level.

From the output control the signal is fed to the input of V2, which is a gating or special type of muting tube. This tube may be used as a switch to turn the subcarrier frequency off and on. V2 also supplies some amplification. The output of V2 is fed directly to the output jack J1.

Audio input is applied to transformer, T1, through a pad which has a loss of 20 DB. The output of T1 drives the two oscillator sections of V1 and V2 in push-pull for increased frequency deviation.

A portion of the output of T1 is fed to muting control R39, and then to audio amplifier tube V3.

The amplified audio signal is then rectified by CR5 and CR6, silicon diodes. Filtering of the rectified audio signal is accomplished by C28 and R46 and is limited to a value of about 6 volts by voltage regulator CR7, a zener diode.

Some of this regulated and rectified audio voltage is applied to the grids of gated amplifier tube, V2. This gating voltage is controlled by function switch, S1.

In position 1 (OFF) of S1, B+ is removed from all stages of the subcarrier generator and the unit is off but is in a standby condition, with filament voltage applied.

Position 2 (S) places the generator into operation and ready to use, provided audio input is applied. Position 2 is the shortest time constant of the muting voltage and this time constant is determined by the components used to filter the the audio.

Position 3 (M) is a longer time constant for the muting voltage. Position 4 (L) is the longest time constant for the muting voltage.

When function switch S1 is in position 5, it defeats the muting capabilities of the unit by applying a portion of the B+ to regulator diode CR7. In this position, subcarrier output will appear at J1 regardless of whether the unit is being modulated by audio or not.

## Adjustment and Setting Up Procedures

The subcarrier generator should be connected to a 150 volt regulated supply and filament supply of 6.3 volts a.c.

Remove audio input modulation and place function switch S1 in position 5 to defeat the muting action. Feed a portion of oscillator #1 as observed at test jack #1 to a frequency counter and set L1 so that the frequency is approximately 800 KC. Then connect the frequency counter to test jack #2 and adjust L2 so that the frequency is 841 KC if the subcarrier frequency is 41 KC, or set L2 so that the frequency observed at test jack #2 is 867 KC if the subcarrier frequency is 67 KC.

Adjust output control R17 so that output may be observed at J1. Connect this point to a frequency counter and trim L2 so that the exact subcarrier frequency is realized. Now set function switch S1 to position 2, 3 or 4 and adjust mute level control R39 to the level desired with audio inputs applied. With mute level control, R39, set in the maximum clockwise position or gate open, it is possible to hold the gate open on a signal which drops by as much as 40 DB.

## Audio Input Levels

Input connections to the subcarrier generator are normally arranged so that input impedance is 600 ohms and that  $\pm 5$  KC swing at 400 cycles audio input is obtained with +10 DBM input level.

150 ohm input impedance can be obtained by connecting the audio input leads of T1 to the leads labeled "white/green" and "red/yellow".

The subcarrier generator can be made to modulate  $\pm 5$  KC swing with an audio input level of -10 DBM at 400 cycles by removing the 20 DB pad between the audio input terminals and the input of T1. This pad consists of R25, 26, 27, 28 and R29.

### Response

No exact standard throughout the industry has ever been set for desired response characteristics of multiplex subcarriers. The most popular response characteristics seems to be about a 50 microsecond pre-emphasis response curve. Response characteristics of the subcarrier generator are provided by C19, C20. These are marked with an asterisk on the schematic. With these capacitors removed from the circuit overall frequency response of the subcarrier generator will be down somewhat at the high end of the audio spectrum. If C20 and C19 are added, the overall frequency response will have a rising tendency at the high end approximating that of a 50 microsecond response curve. See drawing 813-7663-001.

### Modulation of Main Carrier by Subcarrier

The subcarrier generator is designed to fit into the space provided on the M6146 FM Stereo Generator. It can, of course, be used with other units, but the method of setting levels will be described using the FM Stereo Generator unit. The output at J1 should be connected to input jacks J3 or J4 on the subcarrier generator by means of coaxial cable. To set a level, all other modulation should be removed from the main carrier. If it is planned to use 67 KC subcarrier while broadcasting Stereo, the FCC allows the 67 KC multiplex subcarrier to modulate the main carrier 10%.

If stereo is not being used, total modulation of the main carrier by subcarrier shall not exceed 30%. These levels are easy to set by means of the output control, R17, on the subcarrier generator. Modulation percentage can be observed on certain types of FM Monitors. Some monitors will not indicate the proper percentage of subcarrier modulation.

If a proper monitor is not available for measuring subcarrier percentages, the following method may be used to set the subcarrier modulation of the main channel.

First, modulate the main carrier with an audio signal of from 400 cycles to 15,000 cycles. All other modulation should be removed from the main carrier. This modulation percentage may be observed on any type approved monitor. Connect a scope to the discriminator output of some sort of wideband detector that has a good response out to 100 KC. Any type of FM receivers used with FM stereo should have the desired type of response. While modulating the main carrier 10% at say 400 cycles, set a reference level on the oscilloscope. Then remove all modulation from the main carrier. Again, modulate the main carrier with the subcarrier frequency and set the output level of the subcarrier generator to equal this same predetermined setup level.

## MUTING LEVELS AND TIME CONSTANTS

Automatic muting facilities are provided by amplification and rectification of the input audio signal.

With S1 in position 2, 3 or 4 and R39 (MUTE LEVEL) turned clockwise (full on), the following condition exists: carrier output remains full on until input audio level drops 30 db. below the audio input level required to modulate  $\pm 5$  KC. When audio input level has dropped 40 db. below the level needed to modulate  $\pm 5$  KC., carrier output is attenuated 3 db. When audio input level drops 50 db., carrier output is zero.

Proper set-up level will vary from one installation to another and with various receivers. This level will largely be determined by existing crosstalk levels of the installation. To achieve complete muting of the subcarrier when audio input level has dropped less than 50 db., turn mute level control (R39) in a counter clockwise direction.

When function switch S1 is in position number 5 (ON), muting is defeated and there is continuous subcarrier output at J1 regardless of whether there is audio input.

With function switch S1 in positions 2, 3 or 4, various muting time constants are realized as explained in the following paragraphs:

Position 2 (S):

On Switching time - 5 milliseconds  
Off switching time - 225 milliseconds

Position 3 (M):

On Switching time - 80 milliseconds to start,  
100 milliseconds additional (180 total) to  
full subcarrier output.

Off Switching time - 500 milliseconds

Position 4 (L):

On Switching time - 150 milliseconds to start,  
300 milliseconds additional (450 total)  
to full subcarrier output.

Off Switching time - 700 milliseconds

Two additional longer time constants were evaluated by increasing the value of C30 with S1 in position 4 (L).

Results are as shown:

C30 equal 4 mfd:

On Switching time - 600 milliseconds to start,  
750 milliseconds additional (1350 total)  
to full subcarrier output.

Off Switching time - 1250 milliseconds

C30 equal 8 mfd:

On Switching time - 750 milliseconds to start,  
1500 milliseconds additional  
(2250 total) to full subcarrier on.

Off Switching time - 2000 milliseconds

Proper time constant to use will vary from one installation to another and with different receivers. It is also determined somewhat by crosstalk level and subcarrier program content.



## OPERATIONAL AND TECHNICAL ASPECTS

This portion is devoted to an appraisal of the operational characteristics that are realized in the transmission and reception of multiplex background channels. It may assist in a better understanding of some of the peculiarities associated with FM multiplex broadcasting.

In regular AM broadcasting no more than two sidebands are ever generated, unless 100% modulation is exceeded and/or excessive distortion is realized. One sideband will be below the assigned frequency and differ from the assigned frequency by the modulation frequency. The other sideband will be above the assigned carrier frequency and again differ from the assigned frequency by the modulation frequency. See drawing 826 8798 001. At 100% modulation, the voltage, or current, sidebands will be 6 db below the peak carrier deviation. The necessary bandwidth in a receiver IF strip to give us distortionless reception is then 2 times the modulating frequency. If the modulating frequency is 10 KC, then the necessary bandwidth is 20 KC.

Even though AM broadcast channels are spaced only 10 KC apart, there is, in effect, a guard band between adjacent channels, or even several channels, by not placing two transmitters in the same area that are near the same frequency. Our guard band is thus, several times the 10 KC spacing of channels and is a result of distance and transmission attenuation.

In AM broadcasting the 100% modulation figure is a real and maximum figure. It applies regardless of what the carrier frequency may be. In FM broadcasting an entirely different situation exists.

The 100% modulation figure is set merely by convenience. There is no real or actual 100% limiting figure. It was explained previously that in AM broadcasting only two sidebands are generated. In FM many sidebands are generated and the amplitude and number of sidebands is dependent solely upon the frequency deviation or swing and the modulating frequency. The carrier frequency itself does not enter into the calculation of the number of sidebands.

The 5th illustration on drawing 826 8798 001 is an illustration of the sideband distribution and bandwidth of a standard FM broadcast station, broadcasting a 15 KC tone at 100% modulation ( $\pm 75$  KC deviation). For this particular case in point, eight significant sidebands on either side of the carrier frequency are generated. In FM broadcasting for distortionless transmission, it is essential that any sideband that is greater than 1% (40 db) of the peak carrier amplitude must be transmitted or passed.

At the bottom of the illustration #5, is shown frequency deviation. For the case in point, with the modulation index equaling 5 (modulation index equals frequency deviation divided by modulating frequency) the carrier itself is deviating back and forth through a total bandwidth of twice the frequency deviation, or 150 KC. Sidebands generated due to carrier deviation actually occupies a bandwidth of sixteen times the modulating frequency or 240 KC.

Comparing illustration #1 and #5 it is seen that for full fidelity transmission, the required bandwidth for condition #5 is eight times as great as the necessary bandwidth for condition #1.

Illustrations 2, 3 and 4 are for various other modulation indexes as shown. In each case, it is obvious the bandwidth is wider than the case for AM and is also wider than twice the frequency deviation.

On drawing 826 8797 001, entitled "Spectrum Distribution FM Multiplex", the sideband distribution analysis previously explained has been projected to show a real case involving FM broadcast and transmission of two multiplex background channels at 41 KC and 67 KC. The swing on the multiplex channels is being held at  $\pm 5$  KC deviation. Modulating frequency shown is 5 KC.

It is seen that for essentially distortionless transmission the bandwidth of the 41 and 67 KC multiplex channels actually overlap. This drawing shows what is actually being placed into the modulator of the FM transmitter. If nothing happens to alter the transmission and reception characteristics of the FM signal, the ratios shown are what should be seen at the discriminator of the FM receiver. To separate each of the multiplex background channels from the main channel, and to separate each channel from the other requires a certain amount of filtering. Generally speaking the filtering required is in excess of what should be allowed for the distortionless transmission of each multiplex subchannel.

Since main channel modulation is somewhere between 15 to 20 db higher than subchannel modulation, it means that filters employed in the subchannel portion of the multiplex receiver or detector must be a correspondingly amount greater in attenuation characteristics. It can be seen, however, that even if the filter removes all main channel fundamental modulation that harmonics of the main channel modulation may still fall into the 41 or 67 KC pass band. These cannot be completely filtered out. The illustrations on the drawings perhaps exaggerate this somewhat, since it is unlikely that there will be many tones or frequencies at 15 KC modulating the main carrier to the 100% modulation level. On the other hand .5% distortion is very good. In addition, many of the frequencies modulating the main channel will consist of sharp wave fronts and be of the type of signal that generate many higher harmonics.

Drawing 826 8796 001 shows spectrum distribution for FM stereo and one channel of multiplex at 67 KC. This shows that sidebands from the 67 KC background channel are actually starting to fall into the stereo pass band. This cannot be allowed. The sidebands must be reduced by decreasing frequency deviation or by filtering.

Reduction of frequency deviation is recommended. When filters are used to attenuate the pass band of an FM signal, amplitude variations of the carrier result as it deviates back and forth. This in turn may cause crosstalk into the main channel or into the stereophonic subchannel.

When stereo is being broadcast, crosstalk problems into subchannels are multiplied because second harmonic components of the stereophonic subchannel tend to fall into the passband of the multiplex background channel.

#### SUMMARY

The purpose of the foregoing discussion has been to show the technical limitations of the overall system. Overall results obtained in subsidiary communications broadcasting (multiplex) cannot be expected to be as good as that obtained with regular AM broadcasting or with ordinary FM broadcasting. The state of the art, at this time, does not permit this to be.

If bandwidths overlap, it is obviously then necessary to either reduce the frequency deviation, or narrow the bandwidth with filters. Filtering some of the sidebands cause a rise in the detected distortion of the multiplex subchannel. Some compromise between the two situations appears necessary. Also, the greatest bandwidth occurs at the higher modulating frequencies. It, therefore, appears wise to limit the upper frequency response to somewhere between 5 and 8 KC.

For purpose of technical discussion, the reception end on a multiplex signal may be divided into two portions.

1. The main channel detector, which consists of the RF front end, local oscillator, IF strip and discriminator.
2. The subchannel detector, which probably contains filters to separate the main channel from the subchannel and some sort of I.F. strip and then the subchannel detector. The I.F. strip in the subchannel detector will depend upon whether or not the subchannel is being detected at operating frequency or is being heterodyned to some higher frequency such as 455 KC.

Past field experience seems to indicate that the subchannel portion of most multiplex receivers are not capable of better than a 40 db crosstalk figure, when the main channel is modulated above 2 or 3 KC. Passage of the FM multiplex signal through various stages of the Transmitter, antennas and main channel detector may further deteriorate this cross talk figure.

In certain cases, it is possible that crosstalk generated in the transmitter or receiver may be of such a phase as to better the overall crosstalk figure as obtained at the output of a multiplex receiver. Systems wise, this would not hold true. Depending upon phase cancellation to better the overall crosstalk figure cannot be expected to hold true for a group of receivers or antennas and over any period of time.

6/20/62

-12-

994-6160-001

ASSEMBLY INSTRUCTION FOR CONNECTOR P2

<u>Wire No.</u>	<u>From</u>	<u>To</u>	<u>Function</u>
1	P2-C	TS4-1	(6.3 VAC)
2	P2-F	TS4-2	(6.3 VAC)
3	P2-J	TS5-2	(Gnd.)
4	P2-K	TS3-1	(+150 VDC)
Shielded	P2-D	* TB1-11 or 14	(Audio)
	P2-H	* TB1-12 or 15	(Gnd.)
Shielded	P2-L	* TB1-13 or 16	(Audio)

\* Connection depends on which SCA unit (41 KC or 67 KC) is used. Terminals 11, 12 and 13 are used for 41 KC.

Assembly

1. Separate the connector hood from the connector. The polarizing pins hold the two pieces together. A small, stiff wire may be inserted in the holes or the polarizing pins for leverage. Use caution when loosening pins.
2. Insert all wires (four white and one shielded pair) through hood and solder to connector as designated above.
3. Fasten connector hood to the connector using the polarizing pins.
4. Dress the white wire cable along the main cable toward the right edge (opposite hinge) of the chassis door. Spot tie as necessary.
5. Solder ends of white wires to designated terminals. Terminal strips are positioned as follows:

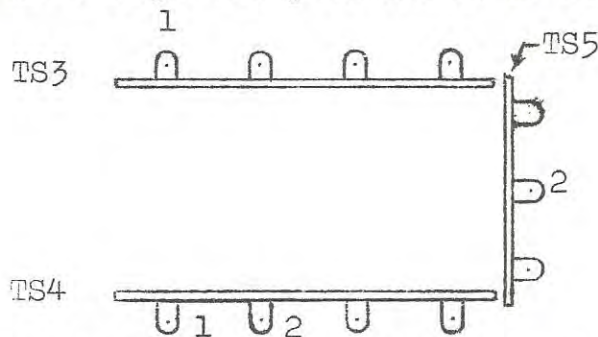

6. Plug connector P2 into receptacle J2 on the Subcarrier unit before turning on the power.

## FIELD INSTALLATION OF THE SUB-CARRIER GENERATOR, M6160

The sub-carrier generator was designed to be mounted in one of the two cutouts on the front of the M6146 stereo generator.

Refer to drawing 937 9642 001 and 814 1678 001.

1. Remove the hood from the male connector, P2, supplied with this unit. (A paper clip may be used to turn the polarizing pins on the connector to separate the hood and plug.)
2. Slide the hood over the end of the supplied power cable that has all wires the same length. Solder these numbered wires to the correct pin designation of the plug. (See drawing 814 1678 001)
3. Feed one pair of shielded audio leads through the hood and solder the wires to the correct pins. Inspect the work to make sure there are not any shorted pins.
4. Re-assemble the hood and the plug of the male connector, P2.
5. Solder the other end of the power cable leads to their correct terminal strip connection. The length of the power cable for each sub-carrier generator is the same. The extra power cable length for the 41 KC unit may be cut off.
6. Install the sub-carrier generator in the correct cutout and plug in P2.
7. Dress the added power cable along the main cable in the stereo generator and lace or spot tie as necessary.
8. Connect the coax cable from the output of the sub-carrier generator to the correct input (J3 or J4) on the stereo generator.

This completes the physical mounting and electrical connections of the sub-carrier generator.

FARTS LIST

M-6160 SUBCARRIER GENERATOR WITH MUTE

<u>Symbol No.</u>	<u>Gates Stock No.</u>	<u>Description</u>
C1, C9	500 0840 000	Capacitor, 680 pf., 300 V.
C2, C10	500 0787 000	Capacitor, 200 pf., 500 V.
C4, C12	500 0822 000	Capacitor, 75 pf., 500 V.
C3, C11	500 0813 000	Capacitor, 33 pf., 500 V.
C5, C8	500 0786 000	Capacitor, 1000 pf., 500 V.
C6, C7	500 0759 000	Capacitor, 100 pf., 500 V.
C13, C14	500 0831 000	Capacitor, 250 pf., 500 V.
C15, C17, C18	516 0054 000	Capacitor, 1000 pf., 1000 V. Disc
C16, C26	516 0082 000	Capacitor, .01 mfd., 1000 V. Disc
C19, C20* C27	506 0004 000	Capacitor, .05 mfd., 200 V.
C25, C32	506 0001 000	Capacitor, .01 mfd., 200 V.
C28, C31	506 0005 000	Capacitor, .1 mfd., 200 V.
C29	522 0073 000	Capacitor, 1 mfd., 50 V.
C30	522 0074 000	Capacitor, 2 mfd., 50 V.
CR1, CR2	528 0002 000	Voltage Variable Capacitor
CR3, CR4, CR5, CR6	384 0073 000	Diode, Silicon
CR7	386 0014 000	Diode, Reference Silicon
J1	612 0237 000	Receptacle, UG-290A/U
J2	612 0375 000	Connector, 11 contact receptacle (Female)

\*NOTE: C19, C20 may vary in test.

6/20/62

-1-

Subcarrier Gen.  
with Mute



FARTS LIST

<u>Symbol No.</u>	<u>Gates Stock No.</u>	<u>Description</u>
L1,L2	492 0035 000	Coil, .44 - .8 MH
L3	494 0092 000	Coil, 25 MH, 75 MA
P1	610 0238 000	Plug, UG-88/U (Part of Cable)
P2	610 0394 000	Connector, 11 contact plug (Male)
R1,R4,R11, R14,R15, R24,R30	540 0097 000	Resistor, 100K ohm, 1/2W. 5%
R2,R13, R18,R41, R44,R47	540 0105 000	Resistor, 220K ohm, 1/2W. 5%
R3,R6, R7,R8, R9,R12	540 0073 000	Resistor, 10K ohm, 1/2W. 5%
R5,R10	540 0065 000	Resistor, 4.7K ohm, 1/2W. 5%
R16	540 0082 000	Resistor, 24K ohm, 1/2W. 5%
R17	550 0242 000	Potentiometer, 10K ohms, 3/4W.
R19	540 0053 000	Resistor, 1.5K ohm, 1/2W. 5%
R20	540 0038 000	Resistor, 360 ohm, 1/2W. 5%
R21	540 0089 000	Resistor, 47K ohm, 1/2W. 5%
R22	540 0084 000	Resistor, 30K ohm, 1/2W. 5%
R23,R45, R46,R48	540 0113 000	Resistor, 470K ohm, 1/2W. 5%
R25,R26, R27,R28	540 0034 000	Resistor, 240 ohm, 1/2W. 5%
R29	540 0027 000	Resistor, 120 ohm, 1/2W. 5%
R32,R37	540 0085 000	Resistor, 33K ohm, 1/2W. 5%
R34	540 0079 000	Resistor, 18K ohm, 1/2W. 5%
R35	540 0098 000	Resistor, 110K ohm, 1/2W. 5%

6/20/62

-2-

Subcarrier Generator  
with Mute - M6160

## PARTS LIST

<u>Symbol No.</u>	<u>Gates Stock No.</u>	<u>Description</u>
R38,R42	540 0121 000	Resistor, 1 megohm, 1/2W. 5%
R39	550 0244 000	Potentiometer, 1 megohm, 3/4 W.
R40,R43	540 0049 000	Resistor, 1K ohm, 1/2W. 5%
R49	540 0135 000	Resistor, 3.9 megohm, 1/2W. 5%
S1	600 0407 000	Switch, sub-miniature rotary
T1	478 0144 000	Transformer, Input AI-10386
TJ1,TJ2, TJ3,TJ4	612 0312 000	Test Point Jack, White
V1,V3	370 0116 000	Tube, 12AX7
V2	370 0152 000	Tube, 5725
XV1	404 0042 000	Tube Socket, Noval
XV2	404 0061 000	Tube, Socket, 7 pin miniature
XV3	404 0063 000	Tube Socket, Noval

6/20/62

-3-

Subcarrier Generator  
with Mute, M6160

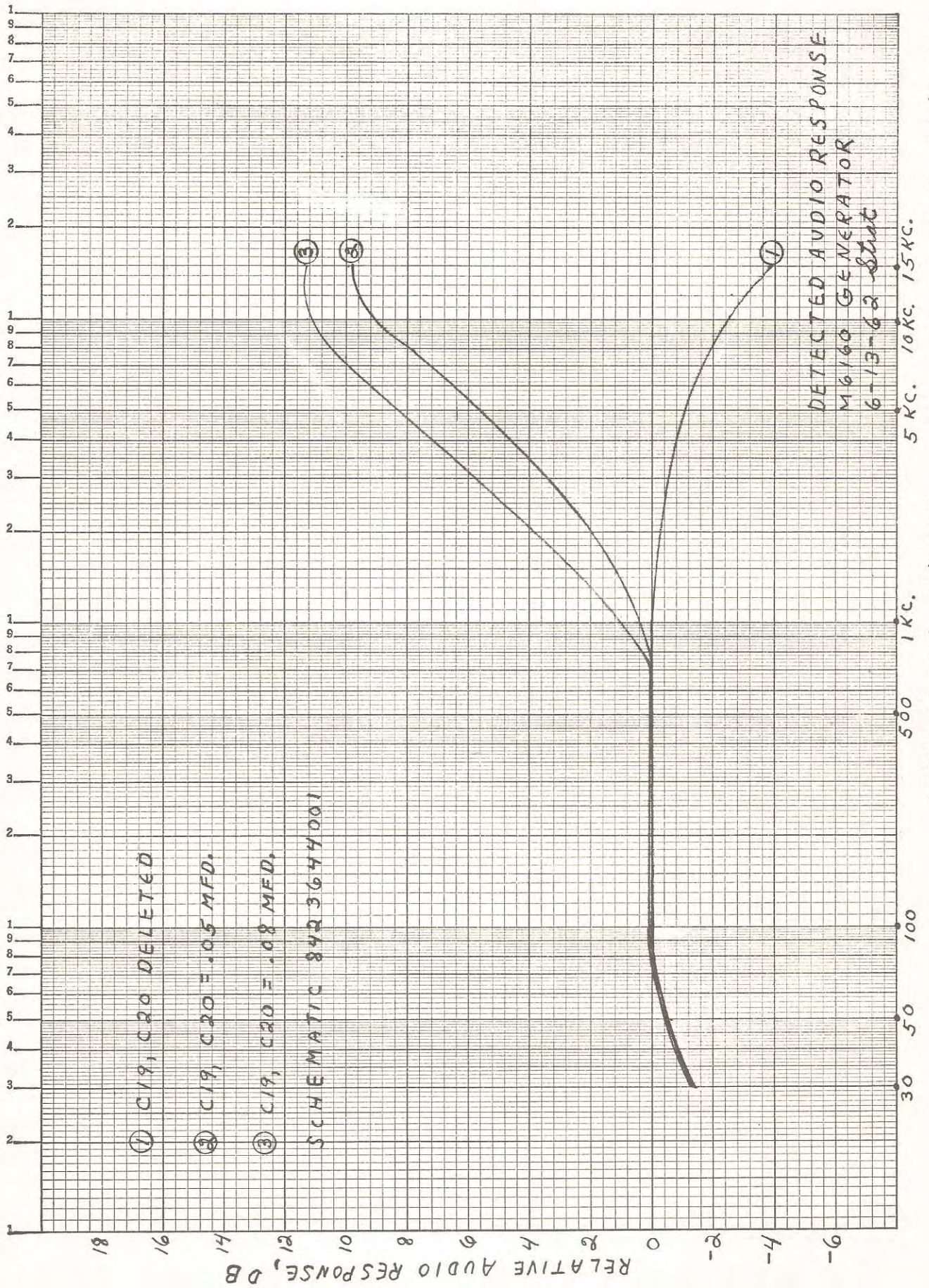

GATES RADIO COMPANY QUINCY, ILLINOIS		826-8773-001	
SCALE			
LIST OF PARTS			
QTY.	QTY.	QTY.	QTY.
106	105	104	103
102	101	gr. No.	
PT. OR QTY.	REFERENCE	FIN.	DESCRIPTION
			MATERIAL

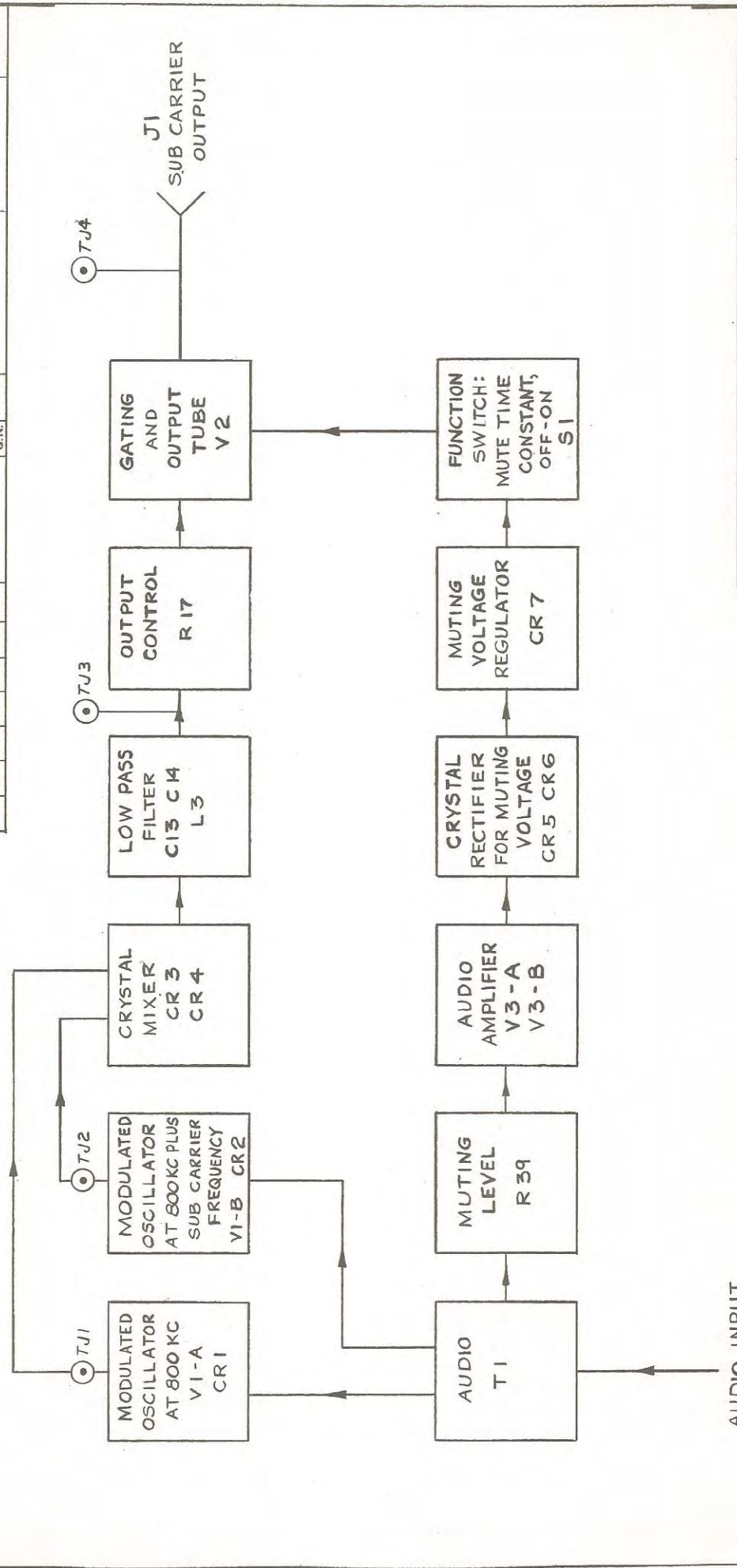

TITLE		BLOCK DIAGRAM SUB CARRIER GENERATOR		M-6160	
STATUS		PRODUCTION		FIN.	
DEVELOPMENT	MECH.	DR. BY/ESC	CH. BY	SHEET	OF
	ENGR.	DATE 6-5-62	6-14-62	1	1
	APPROV. BY	Strat		826-8773-001	
UNLESS OTHERWISE SPECIFIED, ALL TOLERANCES PER GATES APPLICABLE					

GATES RADIO COMPANY QUINCY, ILLINOIS		B-826 8798 001 SCALE	
LIST OF PARTS			
QTY.	QTY.	QTY.	QTY.
106	105	104	103
102	101	GR. NO.	
PT. OF CON.	FIN.	DESCRIPTION	MATERIAL

- ① AM 100%  $\beta = 1$
- ② FM  $\beta = 5$
- ③ FM  $\beta = 1$
- ④ FM  $\beta = 3$
- ⑤ FM  $\beta = 5$

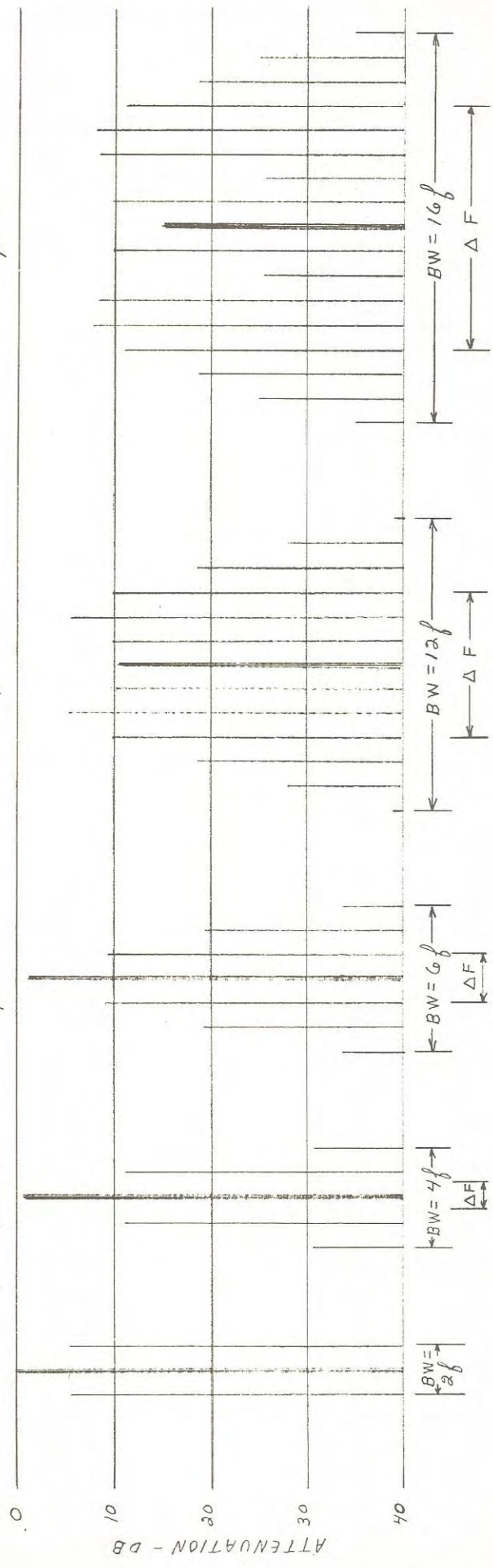

$B$  = MODULATION INDEX  
 $\Delta F$  = FREQUENCY DEVIATION  
 $f$  = MODULATING FREQUENCY  
 $BW$  = BANDWIDTH  
 AM = AMPLITUDE MODULATION  
 FM = FREQUENCY MODULATION  
 $B = \frac{\Delta F}{f}$

STATUS		TITLE	
DEVELOPMENT	PRODUCTION	SIDE BAND DISTRIBUTION VS MODULATION M6160	
MCH.	MTL	FIN.	
PROJ.	DR. BY DATE	CH. BY	SHEET OF
ENG.	ENGL. 6-14-62		1
APPROV.	Start		
PRODUCTION	Start		
UNLESS OTHERWISE SPECIFIED, DIMENSIONS PER GATES SPEC. DRAWINGS.			
			B-826 8798 001

GATES RADIO COMPANY QUINCY, ILLINOIS		826 8797 001 SCALE	
LIST OF PARTS			
QTY.	QTY.	QTY.	QTY.
106	105	104	103
102	101	GR. NO.	PT. GEN.
REFERENCE	FIN.	DESCRIPTION	MATERIAL

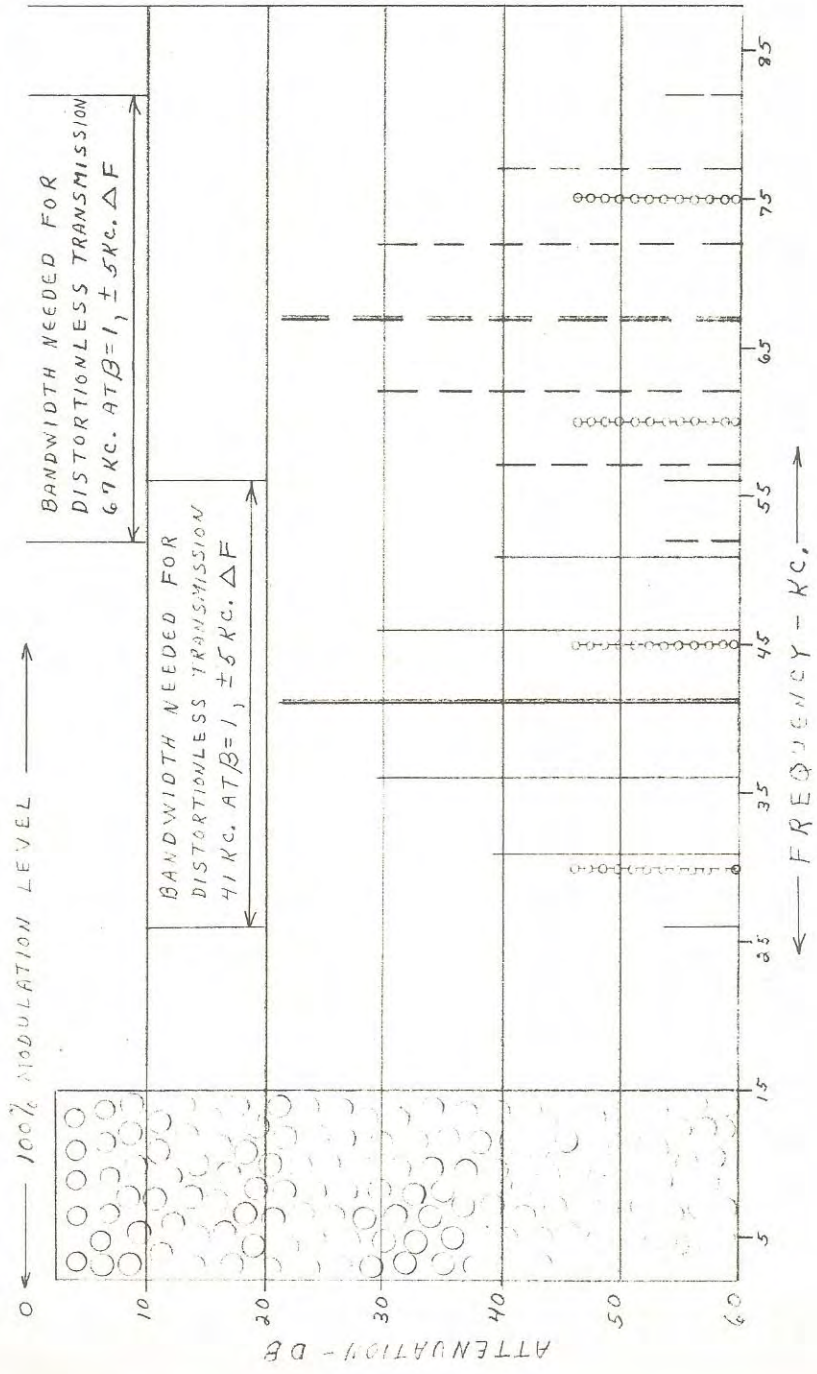

○ = MAIN CHANNEL MODULATION 50 C. TO 15 KC.  
 ⊗ = POSSIBLE SUBCARRIERS CREATED BY -5% DISTORTION OF MAIN CHANNEL MODULATION @ 15 KC  
 | = 41 KC. SUBCARRIER  
 | = 41 KC. SIDEBANDS  
 | = 67 KC. SUBCARRIER  
 | = 67 KC. SIDEBANDS  
 B = MODULATION INDEX  
 ΔF = FREQUENCY DEVIATION

STATUS		TITLE	
DEVELOPMENT	PRODUCTION	SPECTRUM DISTRIBUTION FM MULTIPLEX	
DESIGN	CHK.	M6160	
PROJ. ENG.	APPROV. BY	UNLESS OTHERWISE SPECIFIED, DIMENSIONS PER GATES SPEC STAND.	
PRODUCTION BY	DATE	FIN.	SHEET OF
	6-17-62		826 8797 001

GATES RADIO COMPANY QUINCY, ILLINOIS		826 8796 001 SCALE	
LIST OF PARTS			
QTY.	QTY.	QTY.	QTY.
106	105	104	103
102	101	GR. NO.	ITEM
REFERENCE	PT. G.N.	FIN.	DESCRIPTION
			MATERIAL

- = MAIN CHANNEL MODULATION (L+R)  
50c. TO 15 KC.
- ⊗ = POSSIBLE SUBCARRIERS CREATED  
BY .5% DISTORTION OF MAIN  
CHANNEL MODULATION @ 15 KC.
- = 19 KC. STEREO PILOT
- = 38 KC. DOUBLE SIDEBAND  
SUPPRESSED CARRIER MODULATION
- ▨ = 38 KC. CARRIER (HIGHEST  
PERMISSIBLE LEVEL)
- ⊞ = SUBCARRIER CREATED BY SECOND  
HARMONIC DISTORTION OF □  
WHEN MODULATED
- ≡ = 67 KC. SUBCARRIER
- = 67 KC. SIDEBANDS
- B = MODULATION INDEX
- Δ = FREQUENCY DEVIATION

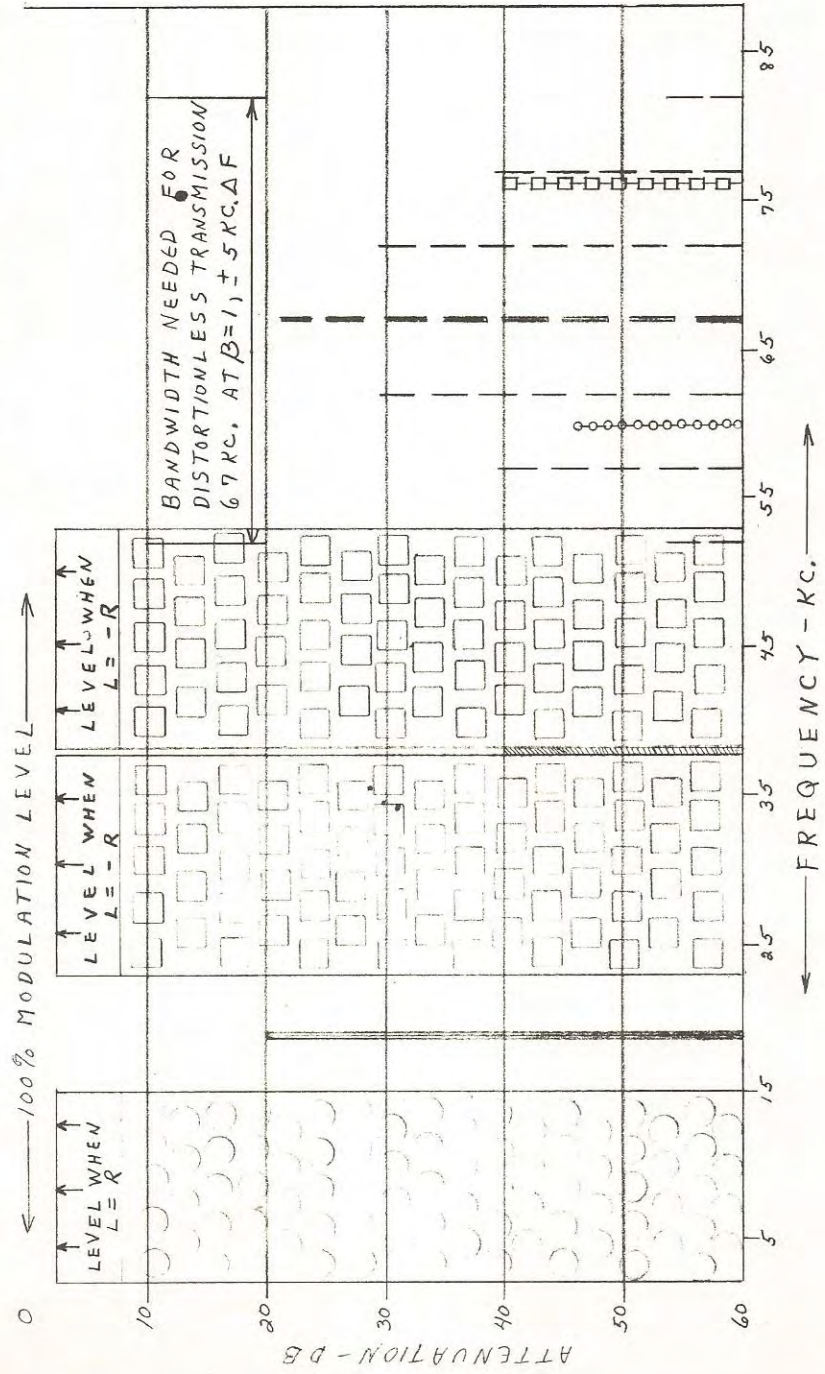

STATUS		TITLE	
DEVELOPMENT	PRODUCTION	SPECTRUM DISTRIBUTION FM STEREO AND MULTIPLEX	
DESK. PRO. ENG.	APPROV. PRODUCTION	MTL	M6160
DR. BY DATE	CH. BY	ENG. 6-15-62	UNLESS OTHERWISE SPECIFIED, ALL DIMENSIONS PER DATES SPEC. SHEET.
		SHEET 62	826 8796 001

GATES RADIO COMPANY QUINCY, ILLINOIS		937-9642-001 SCALE											
LIST OF PARTS													
QTY.	106	105	104	103	102	101	SP. NO.	ITEM	REFERENCE	PT. NO.	FIN.	DESCRIPTION	MATERIAL
								X	1			THIS DWG.	
								80 $\frac{1}{2}$	2			252-0003-000	#20 GA. STRANDED MW-C-20-(7)-U-9

CABLE WIRE	FROM	TO	COLOR	ITEM	SIZE	LENGTH
1	P2-C	TS4-1	WHITE	2	20	19 $\frac{1}{2}$ "
2	P2-F	TS4-2	WHITE	2	20	20"
3	P2-J	TS5-2	WHITE	2	20	21 $\frac{1}{2}$ "
4	P2-K	TS3-1	WHITE	2	20	19 $\frac{1}{2}$ "

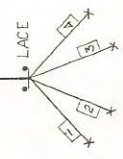
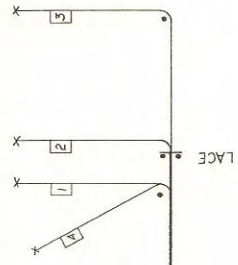

LACE WITH  $\frac{3}{32}$ " WIDE NYLON LACING CORD.  
TERMINATION TO BE TYPE 2.

STATUS		PRODUCTION	
MECH. CHK.	ENG. CHK.	F. J. A.	DATE
TITLE		M. G. 160	
POWER CABLE		SUBCARRIER GENERATOR WITH MUTE	
DR. BY	CH. BY	ENG.	SHEET
DATE	6-25-36		OF
UNLESS OTHERWISE SPECIFIED		ALL DIMENSIONS PER GATES SPEC. DRAWING	
937-9642-001		937-9642-001	



GATES RADIO COMPANY QUINCY, ILLINOIS										842-3644-001	
LIST OF PARTS										SCALE	
QTY.	QTY.	QTY.	QTY.	QTY.	QTY.	ITEM	REFERENCE	PT. G.N.	FIN.	DESCRIPTION	MATERIAL

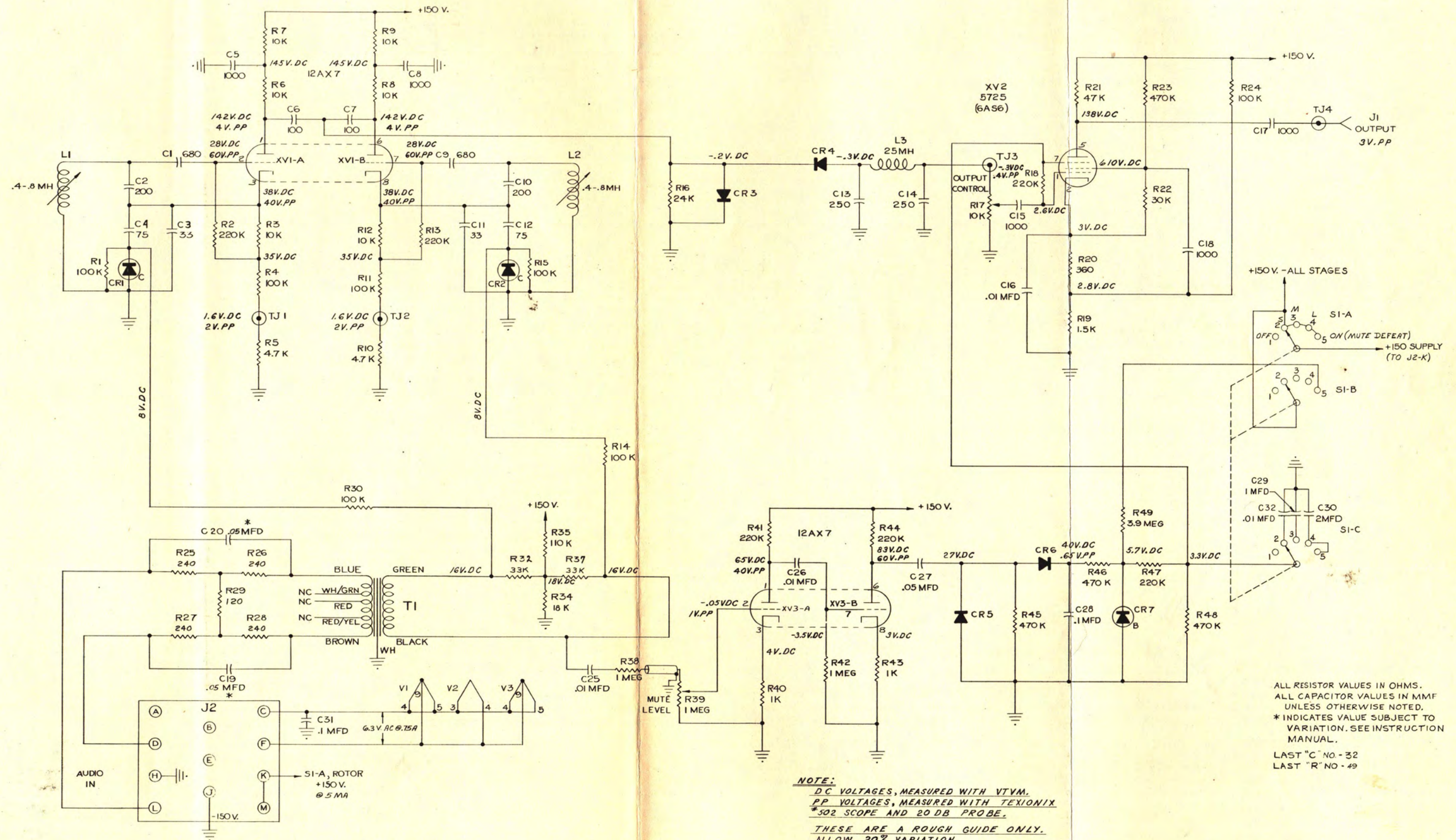

ALL RESISTOR VALUES IN OHMS.  
ALL CAPACITOR VALUES IN MMF  
UNLESS OTHERWISE NOTED.  
\* INDICATES VALUE SUBJECT TO  
VARIATION. SEE INSTRUCTION  
MANUAL.  
LAST "C" NO - 32  
LAST "R" NO - 49

**NOTE:**  
DC VOLTAGES, MEASURED WITH VTVM.  
PP VOLTAGES, MEASURED WITH TEXIONIX  
\*502 SCOPE AND 20 DB PROBE.  
THESE ARE A ROUGH GUIDE ONLY.  
ALLOW 20% VARIATION.  
AUDIO INPUT LEVEL FOR MEASUREMENTS  
WAS +10 DBM AT 400Ω.  
MUTE LEVEL FULL ON.  
S1 IN M POSITION.

If You Didn't Get This From My Site,  
Then It Was Stolen From...  
www.SteamPoweredRadio.Com

TITLE		SCHEMATIC		SUB CARRIER GENERATOR		M6160	
DEV. BY	CHK. BY	ENG. BY	DATE	DATE	DATE	DATE	DATE
DR. BY/MC	CHK. BY	ENG. 6-14-63	DATE 7-62	DATE	DATE	DATE	DATE
SHEET OF				842-3644-001			

SUBCARRIER GENERATOR PLACEMENT IN STEREO GENERATORS  
 - GATES RADIO COMPANY -

POWER CABLE			
WIRE	FROM	TO	FUNCTION
1	P2-C	TS4-1	6.3 VAC
2	P2-F	TS4-2	6.3 VAC
3	P2-J	TS5-2	GND.
4	P2-K	TS3-1	+150 V.

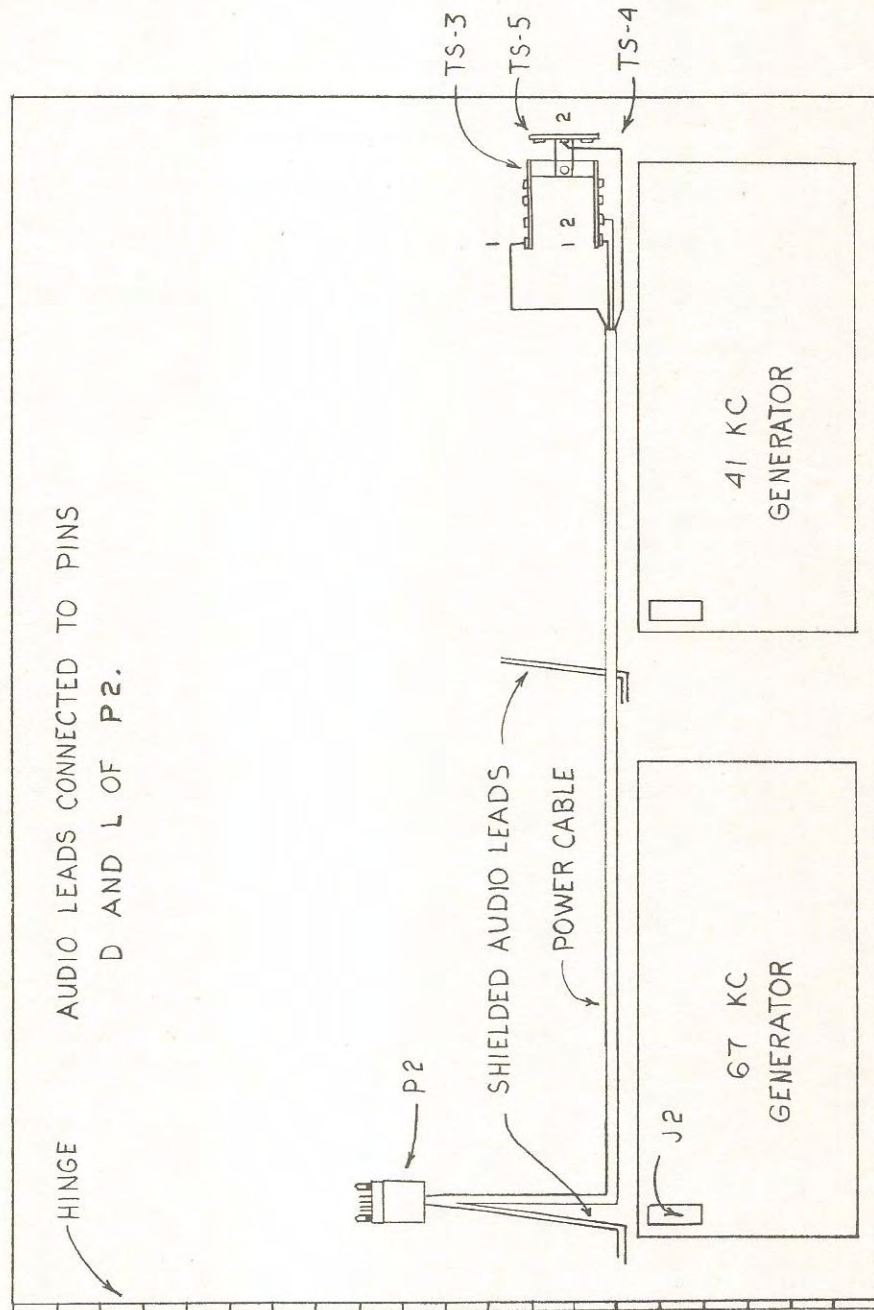

AUDIO LEADS CONNECTED TO PINS  
 D AND L OF P2.

BACK VIEW OF STEREO GENERATOR

# TRANSMITTER READINGS

## AM TRANSMITTER

CIRCUIT	METER READING	DIAL READING	REMARKS
Oscillator Plate Current			
Buffer Grid Current			
Buffer Plate or Cathode Current			
RF Driver Grid Current			
RF Driver Plate Current			
PA Grid Current			
PA Plate Current			
PA Plate Voltage			
PA Efficiency			
Filament Voltage			
Line Voltage			
Mod 1 Static Plate Current			
Mod 2 Static Plate Current			
RF Line Current			

## FM TRANSMITTER

CIRCUIT	METER READING	DIAL READING	REMARKS
Driver Grid Current			
Driver Screen Current			
Driver Plate Current			
Driver Plate Voltage			
RF Output			
VSWR			
Filament Voltage			
PA Grid Current			
PA Screen Current			
PA Plate Current			
PA Plate Voltage			
PA Screen Voltage			
RF Output			
VSWR			
Efficiency			
Filament Voltage			
Line Voltage			

**HARRIS**  
**INTERTYPE**  
**CORPORATION**

**GATES**

**GATES RADIO COMPANY**  
QUINCY, ILLINOIS 62302

Offices in: NEW YORK, HOUSTON, LOS ANGELES,  
WASHINGTON, D.C. Export: ROCKE INTERNATIONAL  
CORPORATION, NEW YORK CITY. In Canada:  
CANADIAN MARCONI COMPANY, MONTREAL.