

GATES

WGMS



If You Didn't Get This From My Site,
Then It Was Stolen From...

www.SteamPoweredRadio.Com

SEP 1961

WGMS-TRANSMITTER

INSTRUCTIONS FOR INSTALLING AND OPERATION
OF
GATES M5952 RECORDING AMPLIFIER

4/28/61

Gates Radio Company
Quincy, Illinois

M5952 RECORDING AMPLIFIER

INDEX

	Page
SECTION I	
SPECIFICATIONS	1
SECTION II	
INTRODUCTION	2
2.1 General	
SECTION III	
INSTALLATION	2
3.1 Unpacking	
3.2 Mounting (15") Custom Unit	
3.3 Mounting (19") Rack Unit	
3.4 Interconnecting The Playback Unit and The Recording Amplifier	
3.5 VU Meter	
3.6 Record Input	
3.6.1 Mic Input -60 to -70 DBM 150/250 Ohm	
3.6.2 Mic Input -60 to -70 DBM 30/50 Ohm	
3.6.3 Bridging Input -20 to +8 DBM 10K Ohm	
3.6.4 Bridging Input -35 to -20 DBM 10K Ohm	
SECTION IV	
PRE-OPERATION	
4.1 Power Switch (S203)	
4.2 Bar Switch Operation (S201 & S202)	
4.2.1 Indicates Power On	
4.2.2 Indicates Cue Tone	
4.2.3 Indicates Record & Actuates Record Start	
4.2.4 Stops Recording	
4.3 Hum Balance Adjustment	
SECTION V	
OPERATION	7
5.1 General	
5.2 Erasing	
5.2.1 To Bulk Erase	
5.3 To Record A Single Segment on One Cartridge	
5.4 Multiple Program Segments on One Cartridge	

- 5.5 To Stop and Start Tape Without Recording
The Cue Tone
- 5.6 Tape Cartridge Preparation for Synchronized
Automatic Sequential Start Operation
- 5.7 Use of The Recording Amplifier
- 5.8 Make Recordings While Other Cartritapes in The
System Are on The Air.

SECTION VI

THEORY OF OPERATION

- 6.1 Record Amplifier 11
- 6.2 Bias Oscillator
- 6.3 Cue Tone Generator
- 6.4 Power Supplies

SECTION VII

MAINTENANCE 13

- 7.1 General
- 7.2 Relays
- 7.3 Bias Current Adjustment
- 7.4 To Measure Bias Current

REPLACING COMPONENTS ON PRINTED CHASSIS

SECTION VIII

PARTS LIST 1 - 4

WARRANTY

- PHOTOS 813 6065 001 - Rear View
813 6064 001 - Bottom View
- DRAWINGS: A-34517 Printed Chassis Component Layout
A-34518 Printed Chassis Parts Layout and
Wire Connection
- 813 5898 001 Record Amplifier Response Curve
813 5911 001 Audio Input Connection (P205)
813 5851 001 Terminal Number Designations for
Jacks and Plugs
- D-23014A Schematic

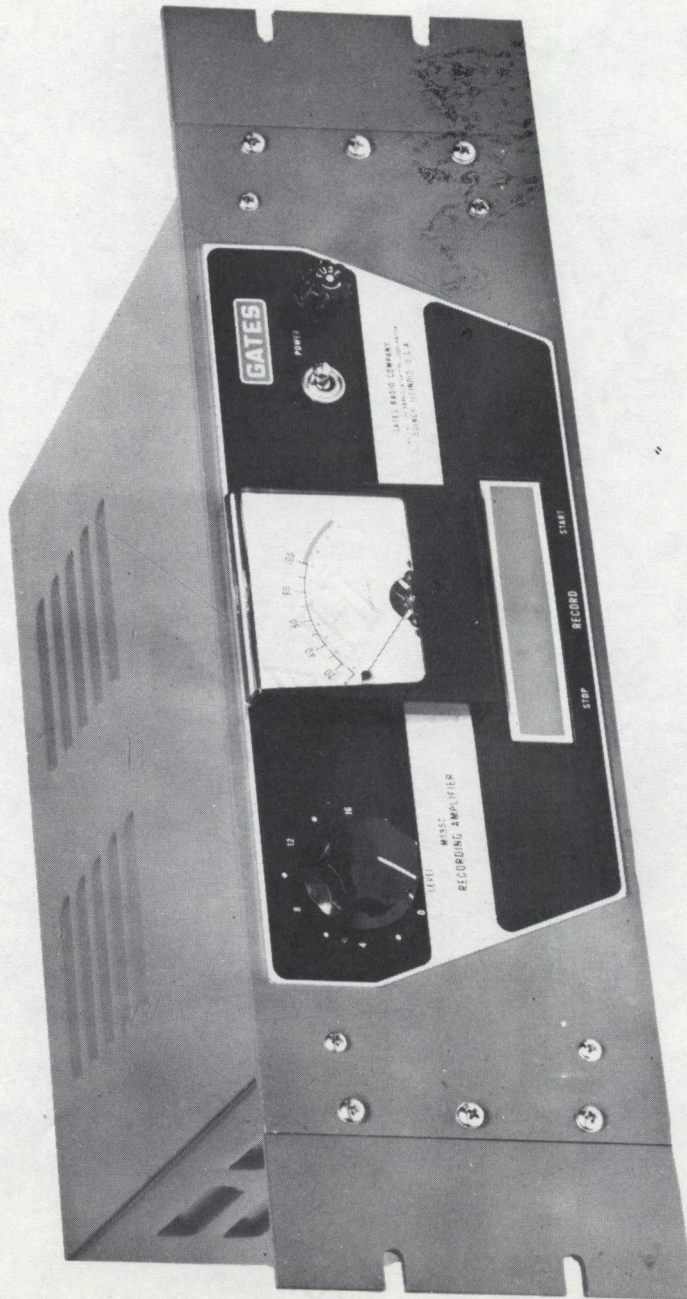

A-34852
(DR-204)

M5952 RECORDING AMPLIFIER

SECTION I SPECIFICATIONS

FREQUENCY RESPONSE: Standard NAB Recording Curves,
± 2 db, 50 to 12,000 cps @ 7.5 IPS.

DISTORTION: 0.5% or less @ normal recording level.

NOISE: -120 dbm or lower, equivalent input noise with
microphone level into matching input circuit.

EQUALIZATION: Standard NAB Recording Curve for 7-1/2
inches per second.

INPUT LEVEL: -60 to -70 dbm matching (30/50-150/250 ohms,
balanced or unbalanced).
-35 dbm to +8 dbm bridging, (10,000 ohms,
balanced or unbalanced).

CUEING ACCURACY: Within 0.1 second.

POWER SOURCE: 115 volts, 50/60 cycles per second.

POWER CONSUMPTION: 25 Watts.

TUBE COMPLEMENT: (2) EF86
(2) 12AX7
(1) 12AU7
(1) 6X4

MECHANICAL

HEIGHT: 5-1/4 inch rack or custom cabinet mounting.

WIDTH: 19 inch rack or 15 inch custom cabinet mounting.

DEPTH: 11 inches behind panel, excluding plugs.

WEIGHT: Net 12 lbs.
Packed (domestic) 27 lbs.
Cubage 3.

4/28/61

-1-

M5952 Recording Amplifier

SECTION II
INTRODUCTION

2.1 GENERAL

The Gates Recording Amplifier, M5952 is an integral part of the Cartritape system. It provides the recording facilities to produce a recorded tape cartridge when connected to Cartritape, M5944. (Playback Unit)

The Recording Amplifier interconnects with one of the playback units, using cables supplied, to form a record/playback combination.

NOTE

A complete Cartritape system wiring diagram consisting of 4 Cartritapes, 1 Switcher, 1 Recording Amplifier and 1 Remote Unit is shown on Drawing 842 3246 001

Units required for recording only or record/playback are -

- 1 - M5944 Cartritape Playback Unit
- 1 - M5952 Recording Amplifier

SECTION III
INSTALLATION

3.1 UNPACKING

The Recording Amplifier will be received in one shipping carton. The 19" rack mounted adaptor kit will be received with the unit. Unpack the contents carefully and examine thoroughly for shipping damage. If any such damage is found, file a claim report immediately with the Carrier.

3.2 MOUNTING (15") CUSTOM UNIT

The unit will be received as a 15" custom unit but supplied with adaptor plates to make the 19" version. The amplifier is designed to be used without an external cabinet, if desired. The other installation instructions apply to both 15" and 19" rack mounting.

3.3 MOUNTING THE (19") RACK UNIT

The unit will be received with an adaptor kit. These adaptors are metal extensions, which must be attached to the recorder front panel, to extend the front panel width to 19". Attach these units with the supplied hardware. The lockwasher should be placed under the screw head.

Mount the unit with four rack screws immediately above or below the Cartritape playback unit to which it is to be interconnected. The cables are long enough to reach the correct jacks and plugs.

3.4 INTERCONNECTING THE PLAYBACK UNIT AND THE RECORDING AMPLIFIER

With the units mounted in place, the following procedure should be followed. (See Drawing 842 3246 001 for system wiring diagram.)

- Step 1. Use the cable harness provided. (14 pin plug on one end and a 12 pin plug on the other end.) Plug the 14 pin plug into J104 (playback unit). Plug the other end (12 pin) into J204 on the recording amplifier.
- Step 2. Remove the phono plug from J102 (red) on the head mounting bracket (pgm head, playback unit). Plug into J202 on the rear of the recording amplifier.
- Step 3. Insert one end of the supplied shielded cable into J102 (playback unit). Plug the other end into J206 on the rear of the recording amplifier.
- Step 4. Remove the phono plug from J103 (cue head, playback unit) and plug into J203 on the rear of the recording amplifier.

- Step 5. Use the other shielded cable supplied and insert one end into J103 (cue head, playback unit). Plug the other end into J207 on the rear of the Recording Amplifier.
- Step 6. Plug the AC cord into J201 and plug the other end into the AC power source.

3.5 VU METER

The VU meter is located in the center of the front panel. This meter is for record level indication only. It does not read bias currents. Set the record level so that audio peaks read 100% or zero VU. The meter should be used for audio reference only. Do not use for frequency response tests, therefore, a gain set should be used for this testing.

3.6 RECORD INPUT FACILITIES (See Drawing 813 5911 001)

The audio input has facilities for bridging a line (-35 to +8 dbm) or mic input of 30/50-150/250 ohms at -60 to -70 dbm. These points are located on J205.

3.6.1 MIC INPUT -60 TO -70 DBM, 150/250 OHM

These input points are located on pins 1 & 3 of P205. (Pin 2 is ground.)

3.6.2 MIC INPUT -60 TO -70 DBM, 30/50 OHM

For 30/50 ohm input impedance the following procedure should be followed on T202.

Step 1. Remove jumper between red/yellow and red.

Step 2. Connect blue to red.

Step 3. Connect red/yellow to brown.

Step 4. The input is located across blue and brown. (Pins 1 and 3). P205.

3.6.3 BRIDGING INPUT -20 TO +8 DBM, 10K OHMS

This input is located between pins 4 and 6 of J205. Pin 2 is ground. Strap pins 5-3 to place

the 150 ohm load resistor, R219, on the pad. The transformer input must be left connected for 150/250 input as it is received from the factory.

3.6.4 BRIDGING INPUT -35 TO -20 DBM, 10K OHMS

This input appears at the same points as 3.6.3, but AT201 requires modification. Connect as explained in 3.6.3 and modify pad AT201 as follows:

- 1) Remove R240, 620 ohms from CKT.
- 2) Strap out R236 and R237, 4.7K ohm.

NOTE

If record/playback response is not to published specifications, adjust bias current as explained in paragraph 7.3 and 7.4.

SECTION IV PRE-OPERATION

The following is a familiarization procedure that should be followed before attempting to place the equipment into operation.

4.1 POWER SWITCH (S203)

The power OFF-ON switch is located on the right hand side of the front panel.

4.2 BAR SWITCH OPERATION (S201 & S202)

The bar switch located under the VU meter performs multiple functions. They are:

- 1) Indicates Power ON
- 2) Indicates CUE TONE
- 3) Indicates RECORD MODE
- 4) Actuates RECORD START
- 5) Stops RECORDING

4.2.1 INDICATES POWER ON

When the power is applied to unit the right side of the bar switch will glow green.

4.2.2 INDICATES CUE TONE

When the record "Start" side of the bar switch is pressed, the record amplifier is set to record. The green light is extinguished. When "Start" on the playback unit is pressed the green light will come back on in the recording amplifier. This tells the operator that the cue tone has been applied.

NOTE

The length of time required for the light to come on after playback "Start" is pressed is the length of time the cue tone is applied to the tape.

4.2.3 INDICATES RECORD AND ACTUATES RECORD START

Also when the bar switch is pressed on the side marked "Start" (as in paragraph 4.2.2) the switch will glow red on the left side. This indicates the unit is ready to record; that is, the bias is applied and the cue tone is ready to be applied, etc. Also pressing the switch on the side marked "Start" switches the recording amplifier to the "Ready" position. The heads are switched, etc.

4.2.4 STOPS RECORDING

The recording process may be stopped at any time by pressing "Stop" on the recording amplifier. This unlatches relay, K201, which removes the recording amplifier from the head. This does not stop the Cartritape,

it only removes the audio from the record head. The Cartritape will continue to run until the cartridge has detected a cue tone and stops.

4.3 HUM BALANCE ADJUSTMENT

For best possible noise figure proceed as follows:

- 1) Remove V206 (the bias osc.) from its socket.
- 2) Remove V205 (the cue tone generator) from its socket.
- 3) Connect ground to pin 6 of J204.
- 4) Connect an audio VTVM across J202 the record head jack.
- 5) Connect power to unit and place in the record mode. Be sure level control is maximum clockwise. Input circuit should be terminated with a 150 ohm resistor.
- 6) Adjust R201 for minimum noise and hum. It will be necessary to polarize the AC plug for minimum hum and noise, between both units.

SECTION V OPERATION

5.1 GENERAL

Operation of the Recording Amplifier is very similar to any high quality recording unit, however, cartridges can be made up for different applications. This section deals with different methods of tape cartridge preparation.

NOTE

There must be at least 4-5 seconds between cue points because of the time delay in the playback unit, otherwise, a cue point may be missed.

5.2 ERASING

The Cartritape unit has no erase head. Therefore, a bulk erasing procedure should be followed.

5.2.1 TO BULK ERASE

- Step 1. Plug bulk eraser into power source.
- Step 2. Bring the erasing unit to the top of the cartridge and make circular motions around the top, bottom and front of the cartridge.
- Step 3. Remove the eraser or cartridge to a distance of about 3 ft. with a slow steady withdrawal.
- Step 4. Remove power to eraser at a 3 ft. distance from the cartridge so that its collapsing field will not re-magnetize the tape.

5.3 TO RECORD A SINGLE SEGMENT ON ONE CARTRIDGE

When one program segment is to be placed on one cartridge, the following procedure is recommended:

- Step 1. Select a completely erased cartridge whose playing time is slightly more than the program time to be recorded. (Nearest standard length).
- Step 2. Insert the cartridge into Cartritape.
- Step 3. Feed audio into the recording amplifier and adjust the gain control so that the audio peaks read 100% on the VU meter.
- Step 4. Press record "Start" on the recording amplifier and preset the program material to be recorded on the cartridge.
- Step 5. Press the "Start" switch on the Cartritape unit and feed the program material source to be recorded as soon after the "Start" switch is pressed as practical.

NOTE

The sooner audio is fed into the recording unit after the "Start" switch is pressed, the tighter the cue, because the instant the "Start" switch is pressed the cue tone is recorded on the tape.

Step 6. After the program material has been recorded, turn down the recording level and allow the cartridge to recue. This will occur when the original starting point is reduced, and will be indicated by the red "Run" light on the playback unit going out.

5.4 MULTIPLE PROGRAM SEGMENTS ON ONE CARTRIDGE

In some applications several segments may be desired on one tape, end to end.

In each case the above procedure applies, except at the end of each segment the STOP button is pressed on the Cartritape. Then the above recording procedure is followed again.

5.5 TO STOP AND START TAPE WITHOUT RECORDING THE CUE TONE

In some applications it may be desired, or necessary, to stop, then start the tape, while recording, without a cue tone being put on the tape. This is accomplished by pressing the START button on the Cartritape before pressing the record START button on the Recording Amplifier. This provision is handy for dubbing in voice and/or other program material into one continuous segment.

5.6 TAPE CARTRIDGE PREPARATION FOR SYNCHRONIZED AUTOMATIC SEQUENTIAL START OPERATION

The Cartritape units may be connected, as explained in the INSTALLATION SECTION, Paragraph 3.9 of this manual, in a

manner that results in one unit being started by the stopping of another.

To use this facility properly, the cartridges must be prepared in a certain manner.

5.5.1 The program material should be timed out (and the correct cartridge playing time selected) so there is little or no dead time between the last segment and the first cue point. "Dead" tape may be removed by editing and re-splicing to insure tight program switching.

5.5.2 No time should be lost between segments. This is accomplished by stopping the tape motion immediately after the segment is recorded on the cartridge by pressing stop on the Cartritape, then proceed with next segment.

5.7 USE OF THE RECORDING AMPLIFIER

The Recording Amplifier is identical in operation (except for cue tone application) to any high quality recording amplifier. Therefore, techniques which are used with standard reel to reel amplifiers can be used with the Cartritape Recording Amplifier.

NOTE

If a frequency response is to be taken it should be done -10 DB down from 100% to avoid tape saturation at high frequencies.

5.8 MAKE RECORDINGS WHILE OTHER CARTRITAPES IN THE SYSTEM ARE ON THE AIR

The Recording Amplifier has been designed so that when the Recording Amplifier is in the Record Mode the starting of that Cartritape interconnected to the Recording Amplifier does not activate the switcher. This feature permits recording while the other Cartritape, in the system, are being used on the air. The only requirement is that

"Record Start" be pressed before "Start" is pressed on the Cartritape.

NOTE

The above explanation applies only when a switcher is included in the system. If a switcher is not used the recording process has no effect on the other Cartritapes being utilized on the air.

SECTION VI

THEORY OF OPERATION

6.1 RECORD AMPLIFIER

The Recording Amplifier is a three stage amplifier with a gain control located after the first stage to facilitate adjusting the recording level. The gain of this amplifier is high enough to record standard level on the tape from a microphone input. The microphone input is 150 ohms or 50 ohms at a level of -60 dbm. -70 dbm will produce approximately 0 or 100% on VU meter. Bridging a -35 to +8 line is possible because of the pad located on the primary side of the audio input transformer, AT201. The first stage is a low noise EF86 tube and is conventional in its configuration. It should be noted that a .005 mfd., is located across the cathode resistor of the second stage. This produces a slight boost on the extreme high end, and is part of the record equalization.

Coupled from the plate of the second stage are two tubes, V204 and V203B. V204 is the last stage of the record amplifier and is connected as a grounded cathode amplifier. However, capacitors, C209 and C213 are wired into the circuit as a part of the record equalization. They provide a boost at the high end. The grid circuit includes an LCR combination to complete the record equalization curve. V203B is the meter driver stage, note that R242 isolates this stage from the previous stage so that circuit loading does not result.

6.2 BIAS OSCILLATOR

V205 is a conventional plate coupled push-pull bias oscillator. It is similar to most of the common ones in use today. This produces high level bias voltage to correctly bias the record head. The push-pull action is needed to give a good sine wave output while keeping the harmonic distortion content low.

6.3 CUE TONE GENERATOR

V206 is a multi-vibrator and is used to generate the cue tone (approximately 1 KC). This tone is applied, without bias, for .1 of a second at the instant the "Start" switch is pressed on the playback unit. This signal is switched through relay K202 to the cue head. Capacitor C225, 8 mfd., across the coil provides a .1 second release time for cue tone application.

6.4 POWER SUPPLIES

There are two power supplies used in the Recording Amplifier. One supplies B+ to the tubes, and the other supplies power to actuate the relays.

The DC source for all the tube circuits is derived from a conventional full wave power supply, using a 6X4 rectifier. Filtering is provided by C201A and C201B. L201, the choke, smooths the ripple further. The preamp tubes have this B+ filtered to an even greater extent by the RC combination of R206 and C201C.

The DC source to actuate the relays is a conventional half-wave type, connected directly to the AC line. The DC voltage is rectified by CR201 and appears across C202. R232 is a surge current limiting resistor.

B+ to the bias oscillator is applied only when the unit is in the record mode.

7.1 GENERAL

The tubes should be checked every 3 to 6 months and replaced when necessary. Dust and dirt should be removed periodically to insure proper operation at all times. A soft brush will facilitate this procedure.

NOTE

When servicing equipment pull AC line plug because a shock hazard is present, this will prevent damage to components as one side of line is hot.

7.2 RELAYS

The relays should be inspected periodically for dust and cleaned when necessary. A relay burnishing tool passed between the contacts (while manually actuated) is sufficient.

7.3 BIAS CURRENT ADJUSTMENT

The correct bias current is necessary to produce a high quality recording. The correct bias current is .8 ma at a frequency of 50 KC to 70 KC.

7.4 TO MEASURE BIAS CURRENT

- Step 1. Insert 100 ohm resistor into the ground return lead of the record/playback head.
- Step 2. Measure the voltage drop across this resistor.
- Step 3. Adjust R201 for .080 volts, measured across this 100 ohm resistor.

NOTE - #1

Be sure to connect the resistor in the ground lead, and connect the meter across the resistor with the ground side of the meter to the grounded side of the resistor, otherwise erroneous readings will occur.

NOTE - #2

HP 400 D is a suitable meter for this purpose.

SECTION VIII

PARTS LIST

<u>Symbol No.</u>	<u>Drawing No.</u>	<u>Description</u>
A201, A202	396 0076 000	Lamp, GE #12
C201	524 0087 000	Cap., 30-20-20 mfd., 350-300-250 V.
C202	522 0116 000	Cap., 40 mfd., @ 250 Volts
C210	500 0771 000	Cap., Variable, 50-380 uuf.
C203	506 0007 000	Cap., .5 mfd., 200 V.
C204, C211, C212	506 0027 000	Cap., .47 mfd., @ 400 Volts
C205, C207, C208	506 0028 000	Cap., .1 mfd., @ 400 Volts
C206	516 0074 000	Cap., .005 mfd., @ 1KV
C209	502 0071 000	Cap., 75 mmfd., @ 500 Volts
C213	502 0196 000	Cap., 400 mmfd., @ 500 Volts
C214	502 0093 000	Cap., 750 mmfd., @ 500 Volts
C215	506 0005 000	Cap., .1 mfd., @ 200 Volts
C217	502 0035 000	Cap., 270 mmfd., @ 500 Volts
C218, C227	516 0054 000	Cap., .001 mfd., @ 1000 Volts
C219, C221	502 0089 000	Cap., 600 mmfd., @ 500 Volts
C220	518 0011 000	Cap., 2.5-13 mmfd.
C222	506 0010 000	Cap., .01 mfd., 400 Volts
C224	522 0288 000	Cap., 10 mfd., @ 150(W) Volts
C225	522 0083 000	Cap., 8 mfd., @ 150 Volts
C226	506 0015 000	Cap., .25 mfd., @ 400 Volts
CR201	384 0020 000	Diode Silicon
F201	398 0019 000	Fuse, 2A, 250 Volt, 3 AG
F202	398 0022 000	Fuse, 5A, 250 Volt, 3 AG
J201	250 0025 000	A.C. Line Cord & Receptacle
(J202, J206), (J203, J207)		Single Phono Socket
J204	612 0247 000	Receptacle, 12 pin
J205	612 0245 000	Receptacle, 6 pin
K201	572 0098 000	Relay
K202	572 0094 000	Relay

5/3/61

-1-

M5952 Recording Amplifier

<u>Symbol No.</u>	<u>Drawing Mo.</u>	<u>Description</u>
L201	476 0003 000	Choke
L202	476 0192 001	Toroid Choke
M201	630 0069 000	VU Meter
(P202, P206), (P203, P207)	250 0034 000	Shielded Cable & Phono Plug
P204	610 0254 000	Plug, 12 pin
R201	550 0213 000	Potentiometer, 250K ohm, 2W.
R202	552 0541 000	Potentiometer, 100 ohm, 2W.
R203	540 0057 000	Res., 2.2K ohm, 1/2W. 5%
R204	548 0046 000	Res., 180K ohm, 1/2W. 1%
R205	540 0119 000	Res., 820K ohm, 1/2W. 1%
R206	540 0492 000	Res., 100K ohm, 1W. 10%
R207	550 0048 000	Potentiometer, 500K ohm
R208	540 0061 000	Res., 3.3K ohm, 1/2W. 5%
R209	540 0206 000	Res., 220K ohm, 1/2W. 10%
R210, R242	540 0214 000	Res., 1 megohm, 1/2W. 10%
R211, R216	540 0101 000	Res., 150K ohm, 1/2W. 5%
R212, R243	540 0109 000	Res., 330K ohm, 1/2W. 5%
R213	540 0180 000	Res., 1.5K ohm, 1/2W. 10%
R214	540 0097 000	Res., 100K ohm, 1/2W. 5%
R215	540 0115 000	Res., 560K ohm, 1/2W. 5%
R217, R233	540 0831 000	Res., 270K ohm, 1/2W. 5%
R218, R222	540 0057 000	Res., 2.2K ohm, 1/2W. 5%
R219	540 0029 000	Res., 150 ohm, 1/2W. 5%
R220	540 0097 000	Res., 100K ohm, 1/2W. 5%
R221	540 0105 000	Res., 220K ohm, 1/2W. 5%
R223	540 0121 000	Res., 1 megohm, 1/2W. 5%
R224, R226	540 0085 000	Res., 33K ohm, 1/2W. 5%
R225	540 0049 000	Res., 1000 ohm, 1/2W. 5%
R227	540 0054 000	Res., 1.6K ohm, 1/2W. 5%
R228	540 0196 000	Res., 33K ohm, 1/2W. 10%
R229	540 0114 000	Res., 510K ohm, 1/2W. 5%
R230, R238, R239	540 0067 000	Res., 5.6K ohm, 1/2W. 5%
R231	540 0073 000	Res., 10K ohm, 1/2W. 5%

5/3/61

-2-

M5952 Recording Amplifier

<u>Symbol No.</u>	<u>Drawing No.</u>	<u>Description</u>
R232	540 0730 000	Res., 150 Ohm, 2 W., 5%
R235	540 0599 000	Res., 330 Ohm, 2 W., 5%
R236,R237	540 0065 000	Res., 4.7K Ohm, 1/2 W., 5%
R240	540 0044 000	Res., 620 Ohm, 1/2 W., 5%
R241	540 0079 000	Res., 18K ohm, 1/2 W., 5%
S201	598 0020 000	Switch Stack
S202	598 0019 000	Switch Stack
S203	604 0005 000	Power Switch
T201	472 0006 000	Power Transformer
T202	478 0145 000	Input Transformer
T203	478 0181 000	Oscillator Transformer
V201	370 0105 000	Tube, 6X4
V202,V204	370 0144 000	Tube, EF86
V203,V206	370 0116 000	Tube, 12AX7
V205	370 0195 000	Tube, 12AU7
XA201,XA202	406 0264 000	Socket
XF201,XF202	402 0023 000	Fuseholder
XV201	404 0032 000	Socket, 7 Pin
XV202,XV203, XV204	404 0059 000	Socket, 9 Pin
XV205,XV206	404 0040 000	Socket, 9 Pin
XCR201	913 4478 001	Diode Mounting Board

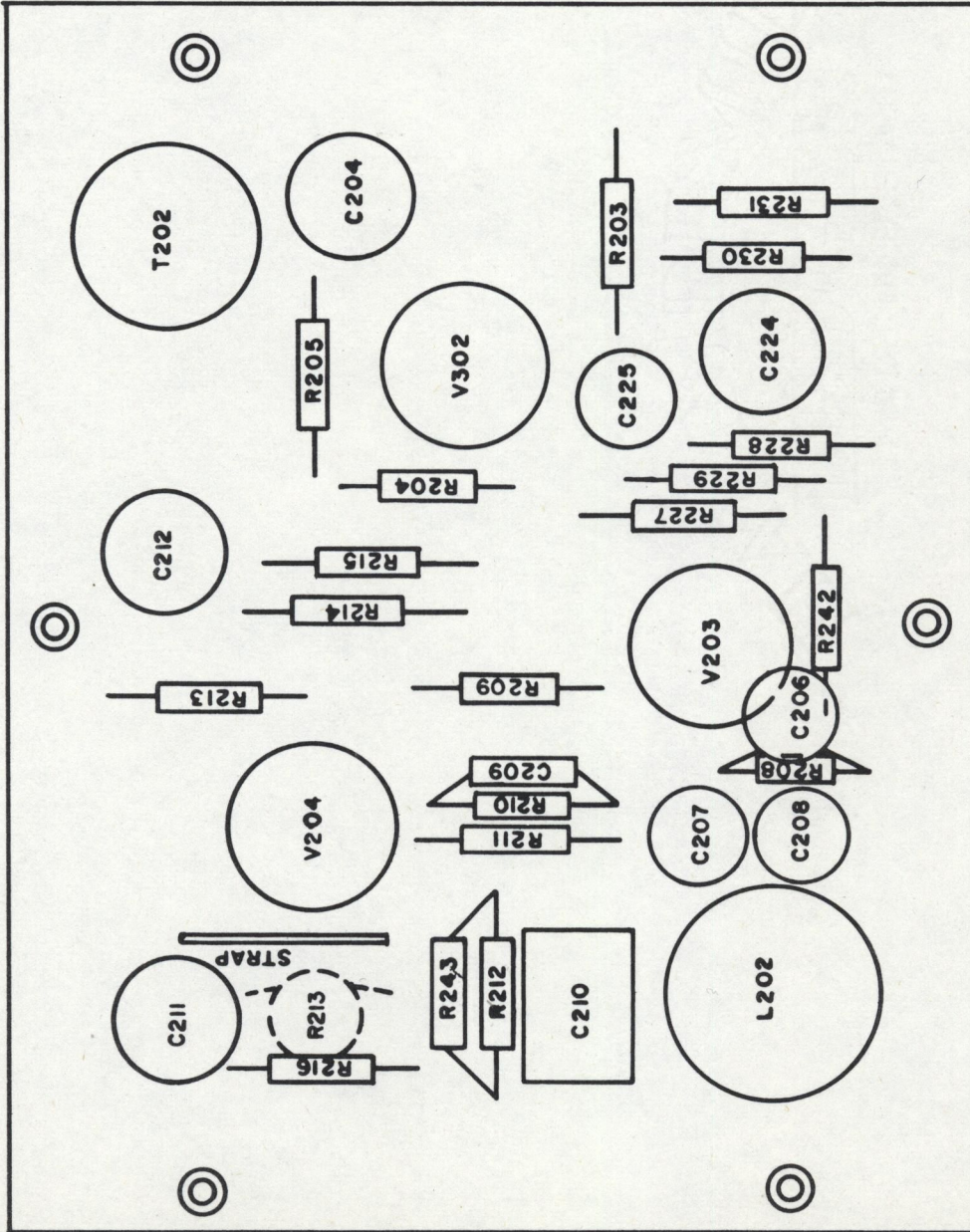

PRINTED CHASSIS COMPONENT LAYOUT
RECORDING AMPLIFIER

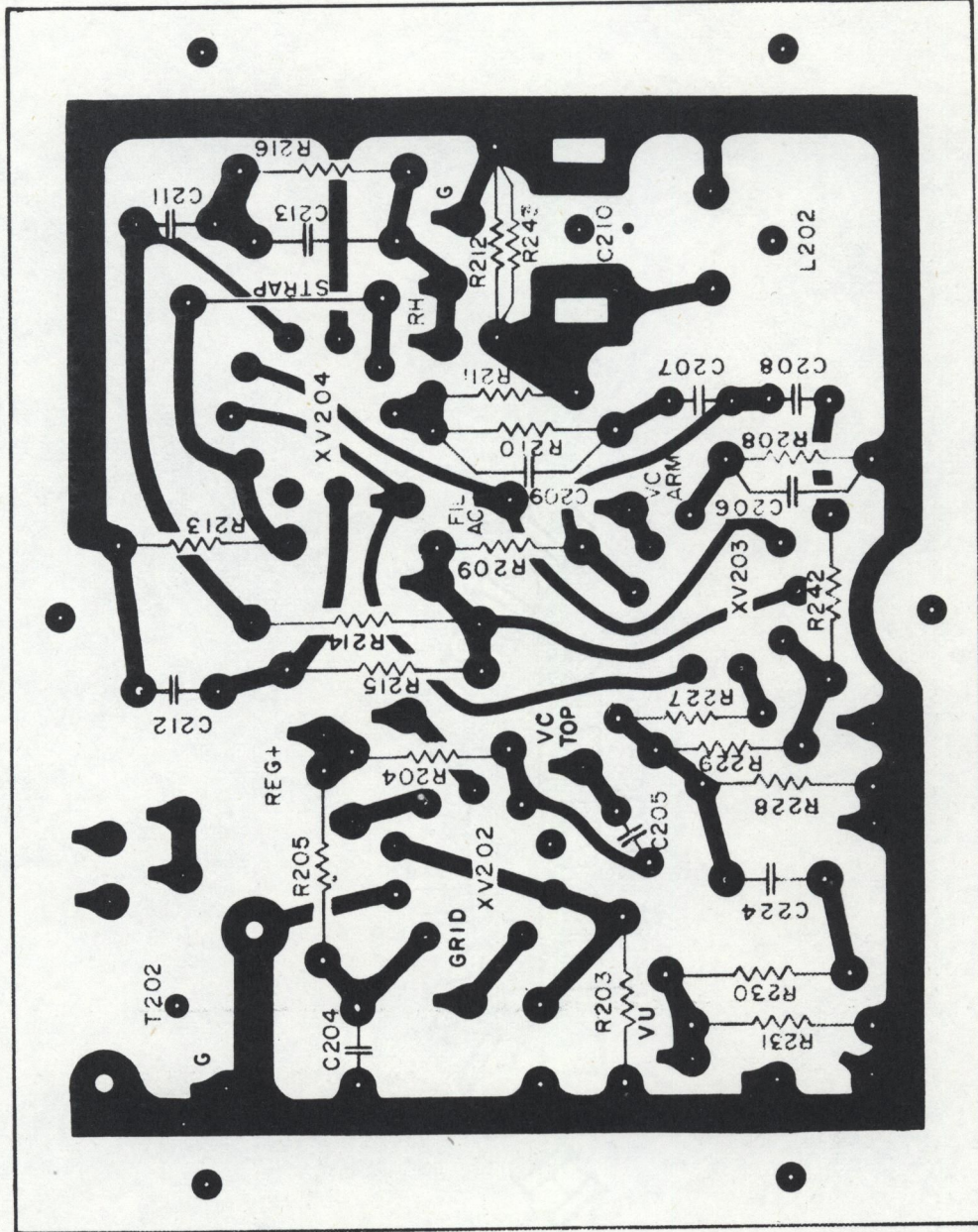

PRINTED CHASSIS LAYOUT SHOWING COMPONENTS AND WIRE CONNECTION RECORDING AMPLIFIER

M-5952

813 4518 001
A-34518

RECORD AMPLIFIER RESPONSE CURVE

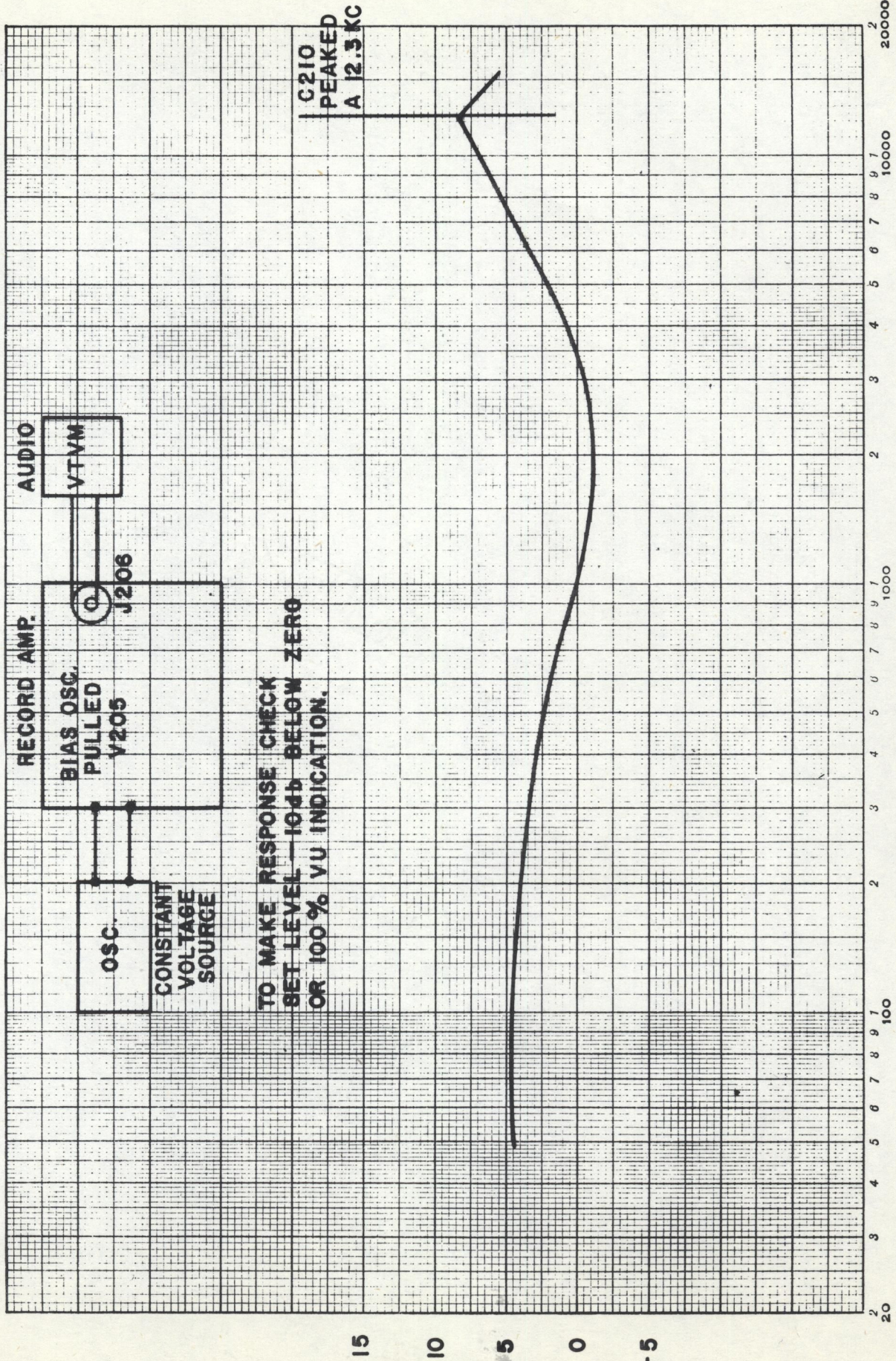

FREQUENCY IN CYCLES PER SECOND

AL R14 3-20-61

104	103	102	101	GR. NO.	REFERENCE	PT. OR G.N.	FIN.	DESCRIPTION	MATL.
-----	-----	-----	-----	---------	-----------	-------------	------	-------------	-------

(1) FOR MIC. INPUT
-70 DBM to -50 DBM

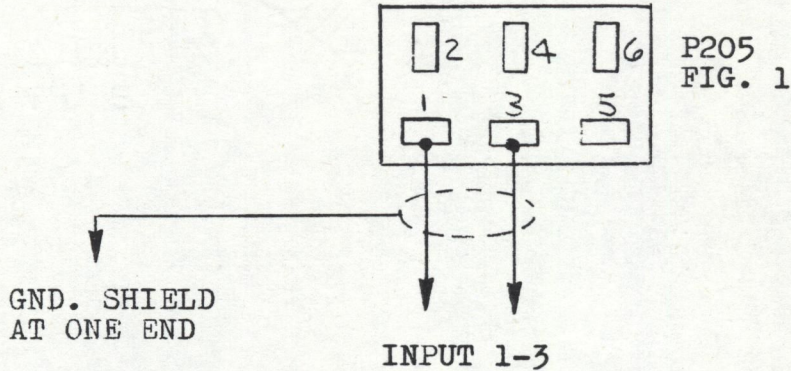

Transformer T202 connected for 150 ohm at factory. T202 may be connected for 30/50 ohm by following instructions in SEC. III in Recording Amplifier Instruction Book.

(2) BRIDGING 10K
HIGH LEVEL -20 DBM to +8 DBM

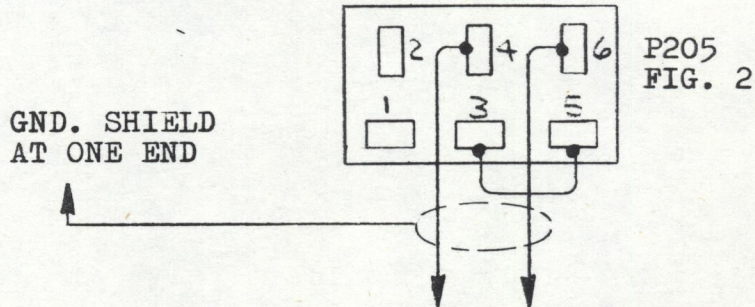

- (1) High Level Input - Pins 4 & 6
- (2) Jumper Pins - 3 & 5

(3) MED. LEVEL BRIDGING
-35 to -20 DBM (P205)

- (1) Input same as above
Pins 4 & 6 (See Fig. 2)
- (2) Jumper Pins 3 & 5
(See Fig. 2)
- (3) Jumper Out R236 & R237
(4.7K) on AT201
Remove R270, 620 ohms

STATUS	
DEVELOPMENT	PRODUCTION
MECH. CHK.	
PROJ. ENG. <i>RAA</i>	
APPROV. PRODUCTION BY	

CH. BY	MTL.
DATE CHECKED BY	
DR. BY <i>NMC</i>	ENG.
DATE <i>3-14-61</i>	FIN.

TITLE AUDIO INPUT CONNECTION TO
M5952 RECORDING AMPLIFIER (P205)
M-5944 CARTRITAPE

UNLESS OTHERWISE SPECIFIED,
ALL TOLERANCES PER GATES
SPEC GSM102.
A 813 5911 001

USE FOR WIRING INTERCONNECTING PLUGS

RECEPTACLE
SHOWN FOR CIRCUIT
TRACING ONLY

PLUGS
USE FOR WIRING INTERCONNECTIONS.
CAUTION: TO REMOVE HOUSING LOOSEN
NUT ON SIDE. DO NOT REMOVE SCREW,
OTHERWISE PLUG WILL COME APART.

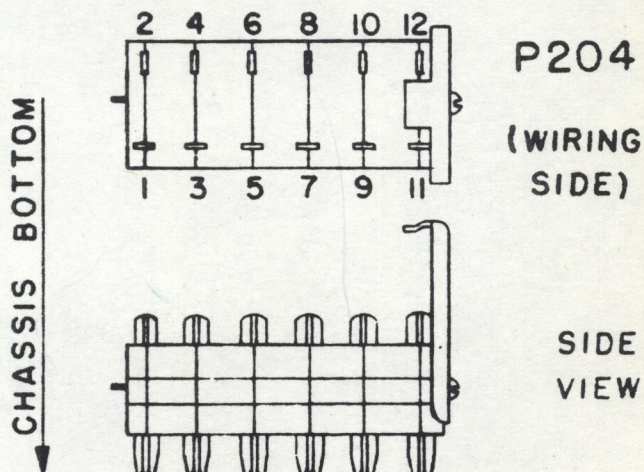
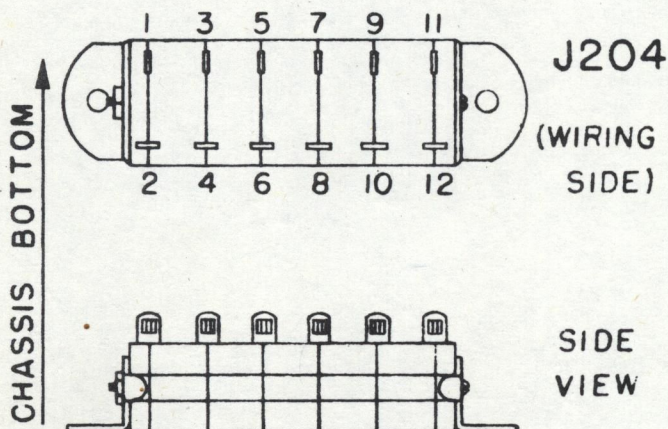
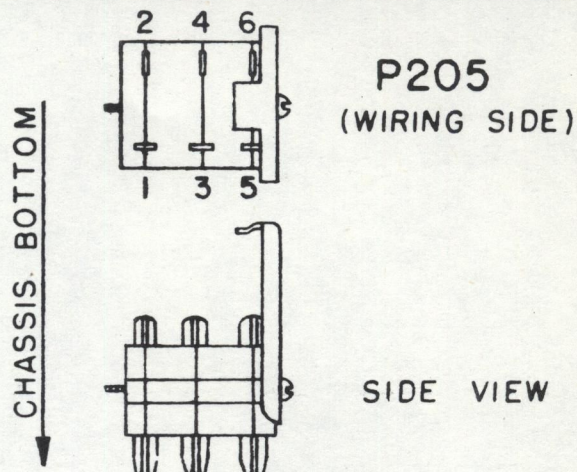
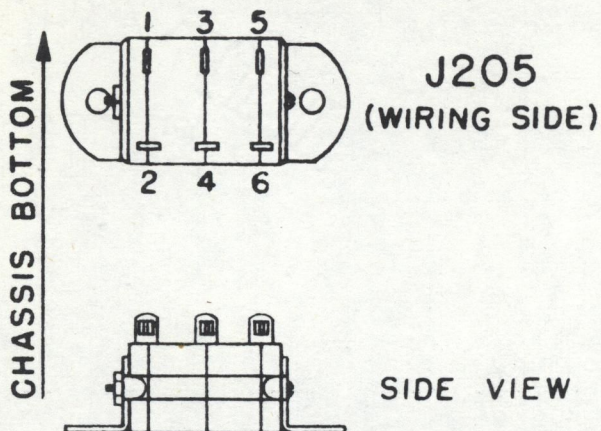

NOTES

- 1) MAKE ALL CONNECTIONS, NUMBERING FROM THE WIRING SIDE ONLY.
- 2) THE JACKS ARE SHOWN FOR REF., ONLY IN CIRCUIT TRACING (DO NOT WIRE TO JACKS).

CH. BY	MTL.	TITLE	
DR. BY	ENG.	TERMINAL NUMBER DESIGNATIONS FOR JACKS AND PLUGS	
G.A. 3-2-61	RdH 3-20-61	RECORDING AMP	M 5952
			813-5851-001

GATES RADIO COMPANY QUINCY, ILLINOIS						D-2301A SCALE	
LIST OF PARTS							
QTY.	QTY.	QTY.	QTY.	QTY.	QTY.	ITEM	REFERENCE
PT. C.N.	FIN.	DESCRIPTION		MATERIAL			

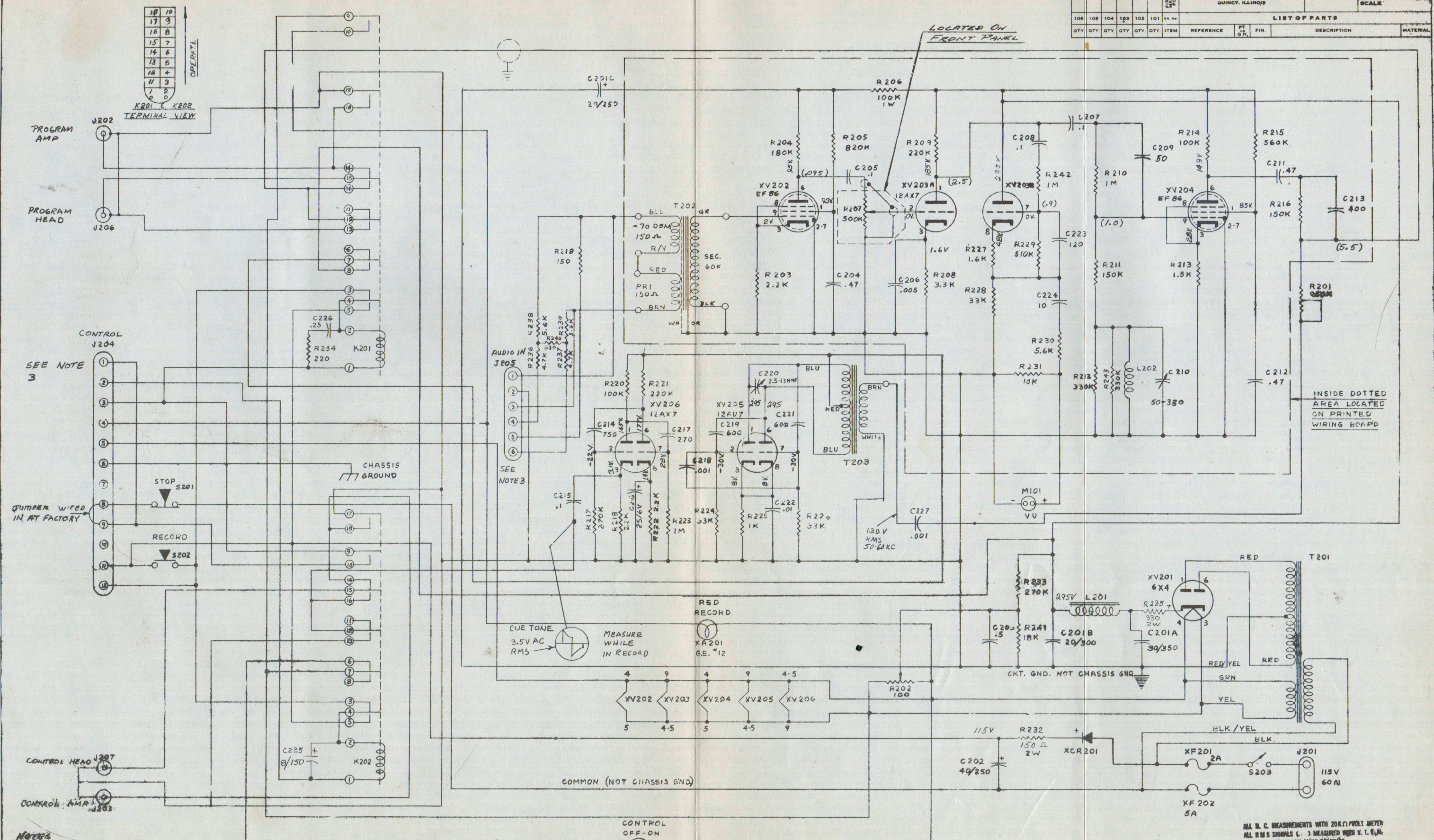

NOTES

1. RMS SIGNAL VOLTAGES SHOWN ARE WITH -70DB AT 150-Ω INPUT, LEVEL CONTROL MAX.
2. DC VOLTAGES ON V205 MUST BE TAKEN WITH THE UNIT IN THE RECORD POSITION.
3. BEFORE WIRING PLUGS SEE DRAWING 813-5851-001 FOR PIN NUMBERING INFORMATION.

If You Didn't Get This From My Site,
Then It Was Stolen From...
www.SteamPoweredRadio.Com

DC VOLTAGES ON V205 & V206 MUST BE TAKEN WITH THE UNIT IN THE RECORD POSITION

ALL D.C. MEASUREMENTS WITH 20K Ω PROBE METER
ALL RMS SIGNALS (C. 3) MEASURED WITH V. T. R.M.
ALLOW 20% ERROR ON MOST READINGS.

TITLE		SCHEMATIC, FOR RECORDING AMPLIFIER	
CARTRIPTAPE		M5952	
DR. BY G.A.	CH. BY	ENG.	SHEET OF 23014
DATE: 10-60			