

# GATES

## BROADCAST EQUIPMENT

AM • FM • TV AND AUDIO



If You Didn't Get This From My Site,  
Then It Was Stolen From...

[www.SteamPoweredRadio.Com](http://www.SteamPoweredRadio.Com)

VOLUME 95

# Introduction

**YOUR NEW CATALOG:** *Gates has prepared this catalog both as an informative book and a buying guide. Whether you are planning a new installation or replacing older equipment you will find the comprehensive selection of equipment in this catalog without equal. For example, if your need is for an audio control console, you can select from Gates standard line of 10 (count them) models. Custom-built equipment is also available. Transmitters of all power ranges and accessory equipment complete this exclusive Gates "TOTAL PACKAGE" concept, or as the consumer industry calls, it "one stop shopping." This means that you can now fill nearly all of your broadcast needs without searching through several sources.*

**TO ORDER:** *Most of the equipment in this catalog is in stock in Quincy or Houston or is in production at one of the Quincy factories. For equipment of a complex nature, or for a "package" system, an experienced sales engineer is at your disposal. Write the Quincy, Illinois, sale office for the name and address of your local representative. For the smaller "need yesterday" items, handy order forms are included which, if filled out properly and thoroughly, will receive fast and efficient treatment in our recently streamlined order department.*

**ABOUT OUR COMPANY:** *Established in 1922, Gates is the senior member in the broadcasting fraternity of many fine manufacturing concerns. Gates has constantly lead in new and progressive equipment design, which will become evident as you progress through this catalog. Recognizing quality as being first in importance, Gates' progressive engineering is backed by a strict quality control operation and one of the world's most modern electronic facilities. Gates field sales service and engineering are international in scope. In addition to our main sales and engineering office in Quincy, Illinois, branch offices are in New York City, Los Angeles, Washington, D.C., and Houston, Texas. The Houston branch carries a generous inventory of capital stock as well as service parts. Sales in Canada are handled exclusively by the Canadian Marconi Co. with its branches in every major city in Canada. International sales are expedited through Rocke International Corporation in New York City. See the back of this catalog for addresses and phone numbers of these Gates branches.*

**OUR CORPORATION:** *Gates is a member of the Harris-Intertype Corporate family, world leader in the graphic arts field. In addition to the Gates facility in Quincy, Illinois, the Corporation has plants in Brooklyn; Cleveland; Dayton; Los Angeles; Westerly, R.I.; Ft. Worth; Slough, England and West Berlin, Germany.*

**FOR BROADCAST EQUIPMENT — THINK OF GATES:** *You will find everyone in the Gates organization fully experienced in radio and TV broadcasting, communications and the industrial electronics field.*

*So, whether it's a "total package" or a transistor, bring your equipment needs to Gates. Each and every member of the Gates organization will do his best to justify the continuing confidence placed in us.*

SINCE  1922

.....**CONTENTS**



**2** BROADCAST TRANS-  
MITTERS AM-FM-TV  
FM STEREO

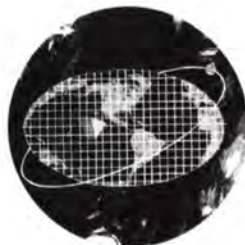

**39** HIGH FREQUENCY  
TRANSMITTERS  
SSB EQUIPMENT



**43** TRANSMITTER  
ACCESSORIES



**62** AUDIO EQUIPMENT  
AND ACCESSORIES



**127** INDEX



**GATES RADIO COMPANY**  
*A Subsidiary of Harris-Intertype Corp.*  
QUINCY, ILLINOIS



# 100,000 WATT AM BROADCAST TRANSMITTER

## Model BC-100C

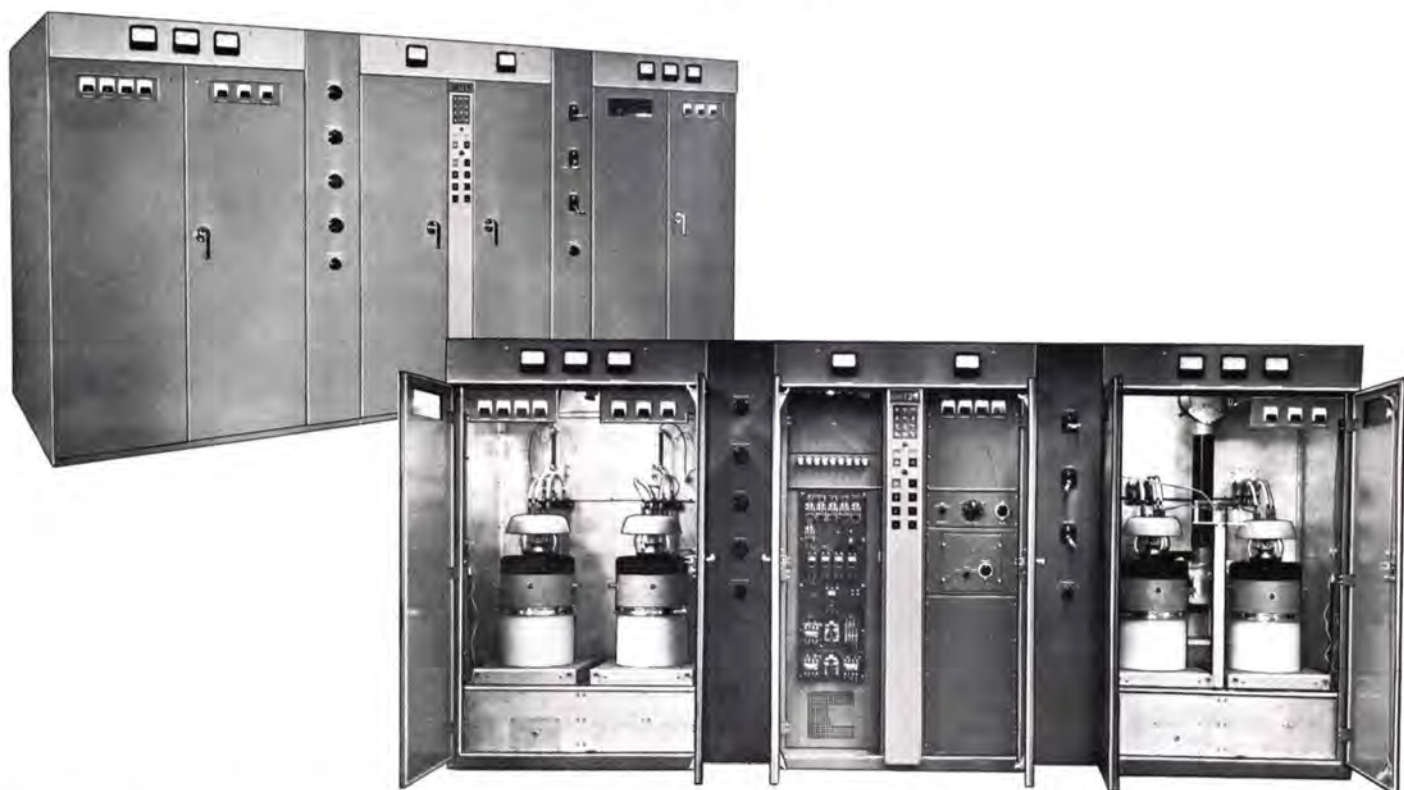

The BC-100C hi-fidelity 100-KW AM broadcast transmitter employs high level modulation for operation on a single frequency between 535 and 1620 kc. The transmitter is field proven and designed to provide unsurpassed reliability when operated in areas of high temperatures and humidity.

Straightforward design, with only six major different tube types; complete air cooling; silicon rectifiers; simple front panel tuning; complete intercubicle wiring and oversized components for extra long life, provide a transmitter with a quality that lends itself to economical operation and simplified maintenance.

**COOLING:** The transmitter, which is housed in 3 bolt-together pressurized cabinets, is completely air cooled. Air from the external blower cools the power amplifier and modulator tubes. Some of this air is diverted to other components. The silicon rectifier columns, mounted in special cabinets, have separate blowers for cooling purposes.

**RF CIRCUITS:** The power amplifier consists of two F-6804 tubes. The plate and grid tuning circuits are mounted in the right cubicle. The RF driver (1 Type 4CX10,000D), the second buffer (2 Type 6146), and the oscillator and first buffer (2 Type 12BY7) are mounted in the center cubicle with the control circuit networks for the complete transmitter.

**MODULATOR AND AUDIO CIRCUITS:** The modulator (2 Type F6804), audio driver (4 Type 304TL), second audio amplifier (2 Type 4-250A), and audio input stage (2 Type 6146) are located in the left cubicle. Inverse feedback is used from the F-6804 tubes to the grids of the audio input stage. This provides one of the highest quality audio signals obtainable with any system of modulation.

**PROTECTIVE DEVICES:** DC overloads are used for each modulator tube, each RF power amplifier tube, and the RF driver. AC overloads are used in conjunction with the start contactors in the two plate supplies for the modulator and RF power amplifier. Blower

start contactors, with thermal overload protection, are provided on the blower motors. Magnetic circuit breakers are used to protect bias supplies, intermediate high voltage supplies, RF driver screen supply, modulator and power amplifier filament transformers plus the regulated 230 volt bus and control circuitry and the three-phase source for the exciter and RF driver cubicle. All filaments are from a three-phase bus, regulated by motor driven variable transformers energizing boost/buck transformers. The correction range is plus or minus 12%, providing an overall regulation of the 230 volt bus to approximately 1%. This provides highly economical tube life and lowest hourly tube cost.

**OPERATION SIMPLICITY:** Features that make the operation of this transmitter ideal for maximum convenience, on-air serviceability and minimum maintenance include:

**METERING:** Full operation monitoring with 22 meters.

**RECYCLING:** Restores high voltage after an overload condition for up to three closely spaced interruptions.

**INDICATOR LIGHTS:** Status is shown of filaments, bias, interlocks, cooling air pressure, excitation, and power change. Indicator lights with a memory are used to show operation of overload relays.

**TRANSIENT PROTECTION:** Silicon cells are each shunted with a transient suppressing capacitor. The high voltage cells also have a shunted resistor.

**TUNING:** Front panel controls for all tuning and adjustment after the original installation.

**AUTOMATIC SEQUENCING:** The start and stop procedure is designed into the control circuitry preventing costly errors in transmitter on and off operations.

The Gates BC-100C transmitter provides a higher standard of performance while maintaining an economy of operation as required by world-wide broadcasters and governmental agencies.

**GATES**

# 100,000 WATT AM BROADCAST TRANSMITTER MODEL BC-100C

## SPECIFICATIONS

### POWER OUTPUT:

105,000 watts at output terminals.

### AUDIO INPUT:

600 ohms balanced, +10 dbm  $\pm$ 2 dbm for 100% modulation.

### AUDIO RESPONSE:

$\pm$ 1.5 db 30-10,000 cycles.

### AUDIO DISTORTION:

3% or less 50-7500 cycles at 95% modulation.

### NOISE:

55 db below 100% modulation.

### FREQUENCY RANGE:

535 Kc to 1620 Kc (operates on one frequency in this range).

### RF OUTPUT IMPEDANCE:

230 ohms (or as specified on special order).

### FREQUENCY STABILITY:

$\pm$ 5 cycles.

### RF HARMONICS:

Suppression of harmonics meets or exceeds CCIR requirements.

### TEMPERATURE RANGE:

-20° to 45°C.

### MODULATION:

High level plate.

### PRIMARY VOLTAGE:

Available for any specific voltage 380 to 460, 3 wire 50 cycles, 3 phase.

### POWER FACTOR:

90% or better.

### POWER CONSUMPTION:

170 Kw at zero modulation.

184 Kw at 30% average modulation.

252 Kw at 100% modulation.

### CARRIER SHIFT:

3% or less at 100% modulation.

### SIZE:

14 ft. wide, 5 ft. deep, 78 in. high for transmitter cabinet. Power transformer, modulation transformer, modulation and filter reactors, HV rectifier and filter capacitor assemblies all mount external.

### WEIGHT AND CUBAGE:

Net weight with external components 22,655 lbs. Export packed, 27,500 lbs.; 1580 cu. ft.

### TUBES:

RF Section—(2) 12BY7 oscillator and 1st amplifier, (2) 6146 buffers, (1) 4CX10,000D RF driver, (2) F6804 final output. Audio Section—(2) 6146 audio input, (2) 4-250A second audio, (4) 304TH audio driver, (2) F6804 modulators. Power Supply second buffer (2) 5R4GY; 230 Volt Regulated Bus Control Unit (1) 12AT7, (1) 6AU6, (1) 6x4, (1) OB2; Holding Bias RF Driver (2) 6V4; Plate Supply Osc./first buffer (1) 6V4; Screen Clamp second buffer (1) 6AQ5, (1) OB2.

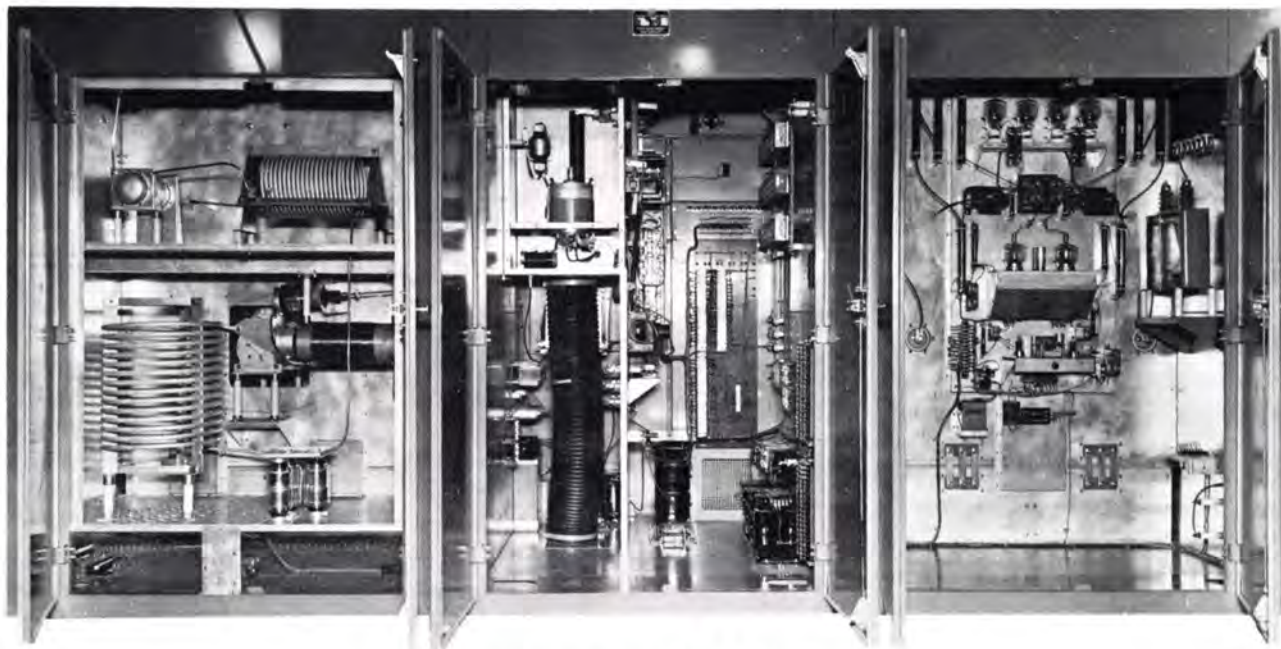

## ORDERING INFORMATION

Model BC-100C broadcast transmitter, 100,000 watts, with tubes and two crystals .....	M-5967
Spare 100% tube complement for BC-100C .....	TK-376
Recommended minimum complement for BC-100C .....	TK-377

# 50,000 WATT AM BROADCAST TRANSMITTER

## Model BC-50C



The excellence of Gates current 50 KW series is demonstrated by the fact that more Gates medium and short wave 50's have been sold in the past few years than any other make. To meet the high standards imposed by the broadcast industry, the BC-50C broadcast transmitter incorporates a multitude of *design exclusives* including: the lowest hourly tube cost of any 50 KW transmitter; high level plate modulation; *choice* of internal or external transmitter cooling; the reliability of oversized components and a proven electrical design; the safety factor provided by 474 silicon rectifiers in the high voltage power supply; each rated at 25 amperes and 500 volts peak; the skillful combination of compact design and complete accessibility; low power consumption and many other improvements and exclusives. Fully FCC type approved, the BC-50C meets the very latest requirements for harmonic attenuation.

**GENERAL DESIGN**—Three cubicles—Modulator, Exciter/Driver and Power Amplifier—join together to form the BC-50C transmitter. External to the transmitter are the high voltage rectifier/contacting cabinet, the capacitor frame, the plate transformers, modulation transformer and reactors. The complete transmitter will fit into any existing

50 kilowatt installation or can be installed in a new site having as little as 750 square feet.

**ELECTRICAL DESIGN**—The RF section of the BC-50C transmitter employs two premium grade vacuum ovenless crystals that provide good stability and require no maintenance. The oscillator and first buffer stages employ 12BY7 tubes, followed by parallel 6146's which in turn excite the 6076 tetrode RF driver. Final RF amplifiers are two Type WL-5891's operating in parallel. This conservative and proven design assures more than ample reserve power output and modulation capability. Four push-pull amplifier stages make up the audio section. Tubes used are two each, Type 6146, Type 813, Type 304TH and Type WL-5891. A low impedance driver source assures an ample reserve modulation capability and exceptional response and distortion characteristics. Overall inverse feedback is employed to further enhance performance. To more than compensate for tube aging and power losses in transmission systems, the BC-50C transmitter has a power output of 55 KW or more. Power consumption is at a minimum. At carrier only 91 KW is consumed and only 105 KW under average programming conditions. The maximum is still

**GATES**

## 50,000 WATT AM BROADCAST TRANSMITTER

only 144 KW under 100% sine wave modulation. This is as low or lower than the power consumption of any 50 KW transmitter now on the market.

All normal tuning adjustments for the BC-50C transmitter can be made from the front panel and complete transmitter tuning by meter indication is possible. The arrangement of the control circuitry has been designed so that modifications and special applications may readily be applied.

**HIGH LEVEL PLATE MODULATION**—The BC-50C utilizes high level plate modulation. High level plate modulation is the most reliable and most frequently used type of modulation.

**TUBE LIFE COSTS**—Gates BC-50C transmitter has only 6 tube types and a total of only 15 tubes. The cost per hour of the major tubes in Gates BC-50C transmitter is the lowest of any 50 KW transmitter. Hourly tube cost is a vital point to consider since a 50 KW transmitter will probably be in use for 20 years or more. Inbuilt automatic filament voltage regulation greatly adds to long tube life in the BC-50C.

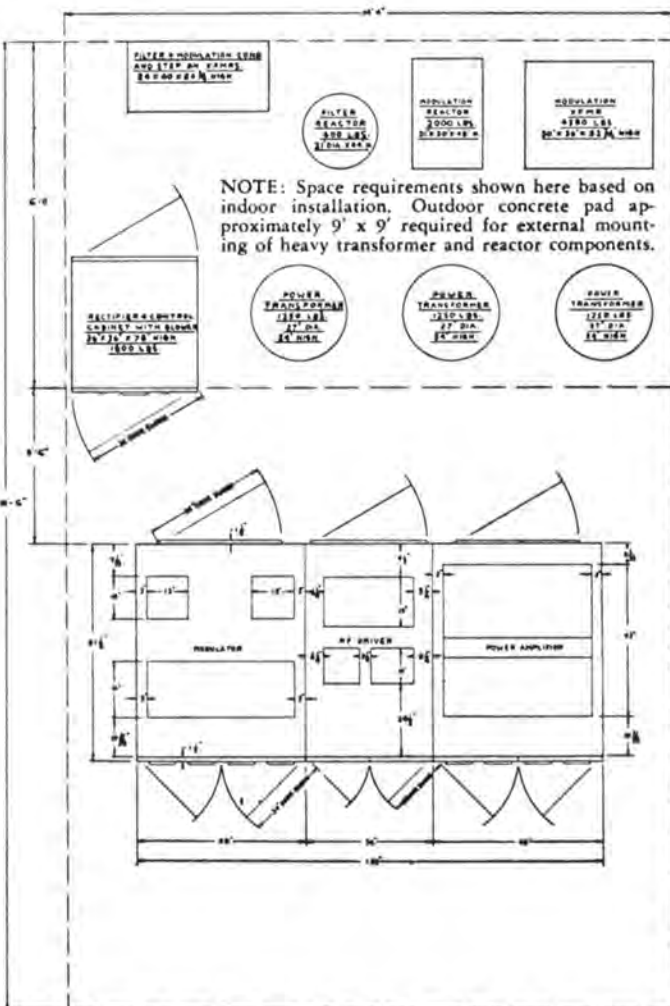

**COOLING SYSTEM**—Gates BC-50C transmitter is available with internal air blowers or with an external blower, as ordered. For internal cooling, the power amplifier cubicle and the modulator cubicle are each supplied with *dual turbine* blowers.

**REMOTE CONTROL**—There are many variables to an in-the-field remote control installation. Gates anticipation of these problems is reflected in the overall construction of the BC-50C transmitter to make it one of the easiest transmitters to remote control. An elaborate system of automatic controls whereby the transmitter "thinks" its sequencing of on-off functions adds to worry-free remote control operation.

**SILICON RECTIFIERS**—Silicon diodes are used in the high voltage power supplies of the BC-50C transmitter. Each diode is rated at 25 amperes and 500 volt peak giving a 500% current and 100% voltage safety factor in the silicon rectifier system.

### SPECIFICATIONS

**POWER OUTPUT:**

50 KW rated (60 KW maximum).

**AUDIO INPUT:**

600 ohms balanced,  $\pm 10$  dbm  $\pm 2$  db for 100% modulation.

**AUDIO RESPONSE:**

$\pm 1.5$  db 30 - 10,000 cycles.

**AUDIO DISTORTION:**

3% or less 50 - 7500 cycles at 95% modulation.

**NOISE:**

60 db or better below 100% modulation.

**FREQUENCY RANGE:**

540 KC to 1600 KC (as ordered).

**RF OUTPUT IMPEDANCE:**

230 ohms unbalanced, (other impedances available on special order).

**FREQUENCY STABILITY:**

$\pm 5$  cycles.

**MONITORS:**

Will accommodate all current models. Gates FCC-approved M-4900 frequency monitor and M-5693 modulation monitor recommended.

**MODULATION:**

High level plate.

**PRIMARY VOLTAGE:**

480 volts, 3 wire, 60 cycles, 3 phase. Other voltages and frequencies available on special order.

**POWER FACTOR:**

90% or better.

**POWER CONSUMPTION: (at 50 KW output)**

91 KW at zero modulation.

105 KW at average modulation.

144 KW at 100% modulation.

# 50,000 WATT AM BROADCAST TRANSMITTER

## SPECIFICATIONS—continued

### CARRIER SHIFT:

5% or less at 100% modulation.

### SIZE:

11' wide, 5' deep, 6½' high (transmitter cabinets).  
See diagram on page 5 for dimensions of external components.

### FINISH:

Medium gloss gray, two tone.

### WEIGHT AND CUBAGE:

Approximately 18,000 lbs. net. Packed weight—22,000 lbs.  
1500 cu. ft with internal blowers.

### TUBES:

#### RF Section

(2) 12BY7 oscillator and 1st amplifier, (2) 6146 buffer, (1) 6076 RF driver, (2) 5891 final output.

#### Audio Section

(2) 6146 audio input, (2) 813 second audio, (2) 304TH audio driver, (2) 5891 modulators.  
FCC Type Accepted.



Rear view showing internal blowers and RF shielding. Where desired, one 10 HP belt driven blower is supplied for installation external to the transmitter and for any type of discharge arrangement.

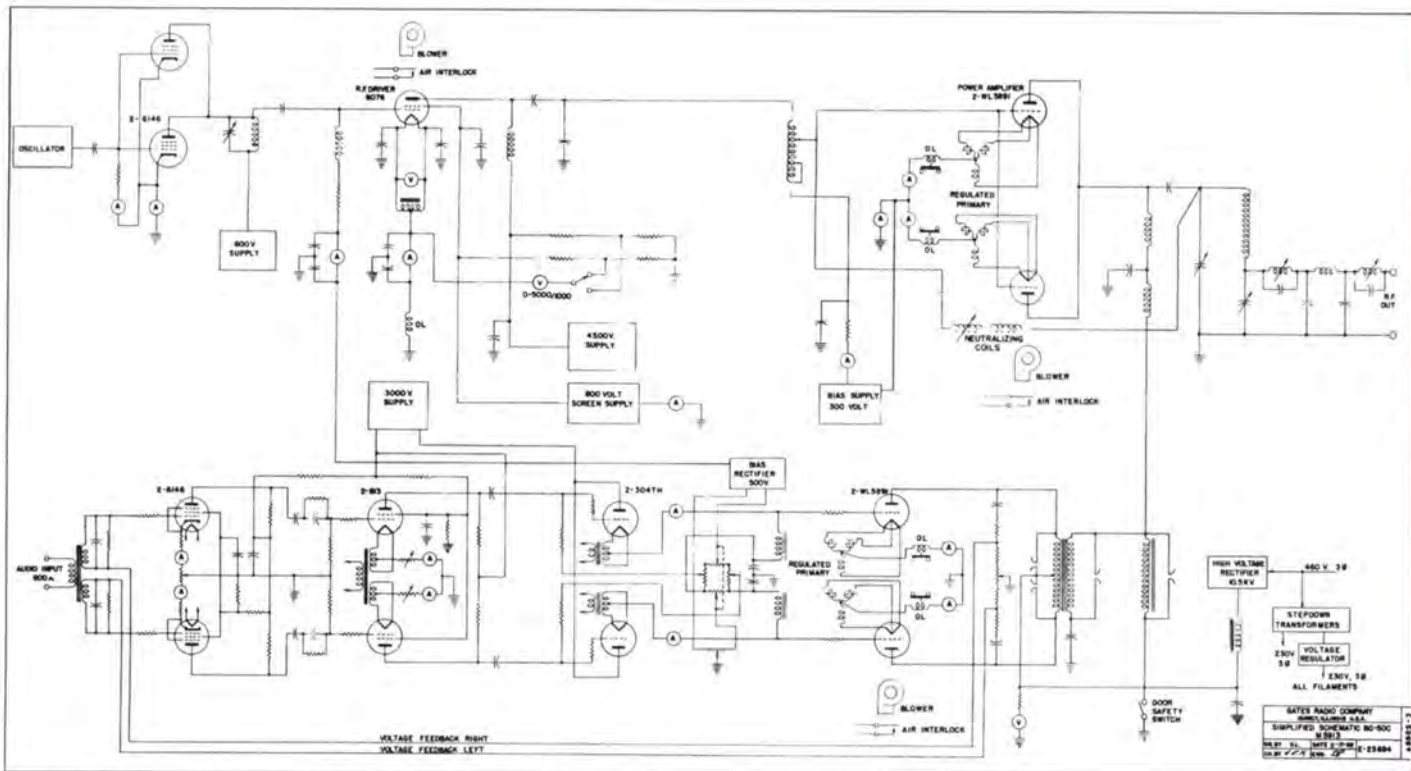

## ORDERING INFORMATION

Model BC-50C broadcast transmitter, 50,000 watts with tubes, two crystals and installation wiring kit .....	M-5913
Spare 100% tube complement for BC-50C .....	TK-367
Recommended minimum tube complement for BC-50C .....	TK-368





# 20,000 WATT AM BROADCAST TRANSMITTER

## Model BC-20B

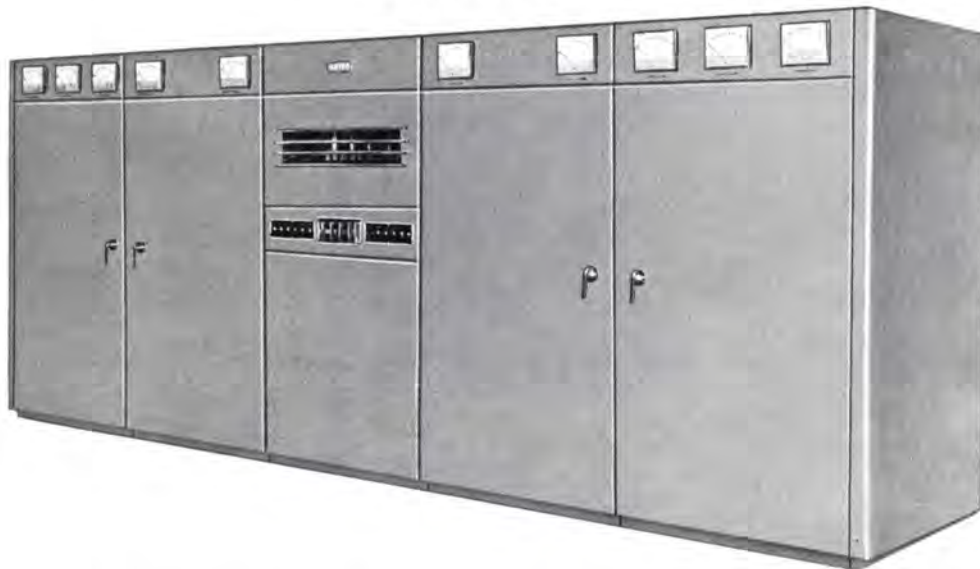

The Gates BC-20B is a 20-KW AM broadcast transmitter employing high level modulation and providing high fidelity transmission in the standard broadcast band of 540KC to 1600KC.

Designed to meet the need for an economical and efficient transmitter, the BC-20B is simple to install. It is housed in five cabinets which do not require intercubicle cabling. Power and modulation components are external. Four type 3X2500F3 tubes are used in the push-pull power amplifier, providing remarkable low distortion and wide response. Straight forward modern circuitry is employed in the five RF stages and in the four push-pull audio stages.

Separate full wave, 3-phase, high voltage power supplies for the RF power amplifier and modulator illustrate the conservative design of the BC-20B for maximum reliability. Gates BC-20B transmitters are field proven in world-wide service in areas of extreme temperature and humidity conditions.

### SPECIFICATIONS

#### POWER OUTPUT:

Rated 20,000 watts. Capable 21,250 watts.

#### AUDIO INPUT:

+8 db  $\pm$ 2 db for 100% modulation.

#### AUDIO RESPONSE:

$\pm$ 1½ db, 50-10,000 cycles.

#### AUDIO DISTORTION:

3% or less, 50-7500 cycles at 95% modulation.

#### FREQUENCY RANGE:

540 to 1600 Kc as ordered.

#### RF OUTPUT IMPEDANCE:

40-270 ohms.

#### FREQUENCY STABILITY:

0.005% or better.

#### MODULATION:

High level plate. Modulator and PA have separate HV supplies.

#### PRIMARY VOLTAGE:

230 volts, 3 wire, 3 phase, 50/60 cycles.

#### POWER CONSUMPTION:

37.6 Kw at zero modulation, 42.5 Kw at average modulation, 57.5 Kw at 100% modulation.

#### CARRIER SHIFT:

5% or less at 100% modulation.

#### SIZE, WEIGHT, CUBAGE:

78" high, 210" wide, 49" deep. Front door swing, 40". Floor space external transformers, 10' x 2½'. 19,500 lbs. net, 23,000 lbs. packed. 720 cu. ft.

#### FINISH:

Medium gray with trimmings in chrome, brushed aluminum and anodized black.

#### TUBES:

(Radio Frequency) 6V6 osc., 807 IPA, 6146 IPA, (2) 4-250-A IPA, (4) 3X2500F3 power amplifiers. (Audio Section) (2) 6J7 1st audio, (2) 807 2nd audio, (2) 845 3rd audio, (4) 3X3000F1 modulators. (Power Supplies) (12) 673, (6) 8008.

### ORDERING INFORMATION

BC-20B broadcast transmitter, 20,000 watts, with tubes, one crystal and oven

M-4779

Spare 100% tube complement for above

TK-229

Spare crystal and oven

JK-57M

# 10,000 WATT AM BROADCAST TRANSMITTER

## Model BC-10P



The BC-10P is a completely self-contained 10 KW AM broadcast transmitter. It has been designed with emphasis on reliability, wide frequency response, less floor space and low operating and replacement tube cost. Power amplifier and modulator tubes are interchangeable.

Harmonic radiation is realistically reduced by constructing the entire radio frequency section within a heavy aluminum enclosure. The tank circuit is inductively tuned and includes a full Tee network.

Fidelity of the BC-10P transmitter extends to 15,000 cycles. The use of cathode follower audio drive, over-all feedback and over-powered RF grid drive assures day to day low distortion without exhaustive alignment and balancing. Not to be overlooked is the use of low impedance modulator tubes where transformer ratio between modulator plates and Class C amplifier impedance is near unity and conducive to best audio transfer at high efficiency and lower distortion.

The transmitter consists of three cubicles which contain as separate units, a power supply, modulator, and radio frequency unit. There are no external components.

**RF SECTION:** The complete RF section is in the right cubicle. A single ended 3X2500F3 air-cooled power amplifier feeds a full "T" network. Tank and load tuning is by variable coils. Dual vacuum

precision crystals excite an untuned Colpitts oscillator. Following the 6146 IPA stage, a type 4-400A tetrode drives two 3X2500F3 power amplifiers in parallel. Maximum output of 10,600 watts accommodates complicated multitower phasors.

**MODULATOR:** The modulator/audio section is in the left cubicle. There are four push-pull stages with over-all feedback. Dual 3X2500F3 modulators are interchangeable with the RF power amplifiers.

**POWER SUPPLY:** The center cubicle contains the three low voltage supplies and the 3 phase full wave (six Type 673 Rectifiers) high voltage supply. The transmitter is also available with 100% silicon rectifiers.

**RECYCLING:** In case of DC overload, transmitter automatically recycles and places itself back on air. A rapid succession of overloads removes the high voltage. For remote control, this feature is indispensable.

**GATES**

## BC-10P 10,000 WATT AM BROADCAST TRANSMITTER

**PROTECTIVE DEVICES:** Relays are used for overload, start, stop and interlock protection. No major mechanical alterations or addition of control relays is necessary to adapt the transmitter for remote control.

**COOLING:** Two squirrel cage shock mounted blowers cool RF and modulator cubicles including tubes. Exhaust fan installed in ceiling of rectifier cubicle. Single phase motors are used for easy servicing and maintenance.

### SPECIFICATIONS

**POWER OUTPUT:**

Rated 10,000 watts, capable 10,600 watts.

**AUDIO INPUT:**

600/150 ohms. 0 db for 100% modulation ( $\pm 2$  db).

**AUDIO RESPONSE:**

$\pm 1\frac{1}{2}$  db, 30-12,000 cycles.

**AUDIO DISTORTION:**

3% or less, 50-7,500 cycles at 95% modulation.

**NOISE:**

60 db or better below 100% modulation at 10KW power.

**FREQUENCY RANGE:**

535-2,000 kc (as ordered).

**RF OUTPUT IMPEDANCE:**

40-370 ohms (as ordered).

**FREQUENCY STABILITY:**

$\pm 5$  cycles.

**MONITORS:**

Will accommodate all current models. Gates FCC-approved M-4990 frequency monitor and M-5693 modulation monitor recommended.

**MODULATION AND FREQUENCY MONITOR COUPLING IMPEDANCE:**

50/70 ohms.

**MODULATION:**

High level plate.

**PRIMARY VOLTAGE:**

230 volts, 3-phase, 50/60 cycle delta. (208 volts available on special order.)

**POWER CONSUMPTION:**

19.2 KW at zero modulation, 21.7 KW at average modulation, 28.8 KW at 100% modulation.

**CARRIER SHIFT:**

3% or less at 100% modulation.

**SIZE:**

78" high, 73 $\frac{1}{2}$ " wide, 39 $\frac{1}{2}$ " deep.

**FINISH:**

Two-tone medium gloss gray with trim in brushed aluminum and black.

**WEIGHT AND CUBAGE:**

Net 2650 lbs., 3400 lbs. packed. 198 cu. ft.

**TUBES:**

12BY7 osc., 12BY7 1st amp., 6146 buffer, 4-400A RF driver, (2) 3X2500F3 power amplifier, 6SN7 1st audio, (2) 6BG6 2nd audio, (4) 6528 audio driver, (2) 3X2500F3 modulator, 6W4\* driver hold bias rectifier, 6W4\* PA hold bias rectifier, (2) 5U4G\* audio plate rectifier, 5U4G\* modulator bias rectifier, (6) 8008\* main rectifier.

\*Omitted where silicon dry rectifiers are employed.

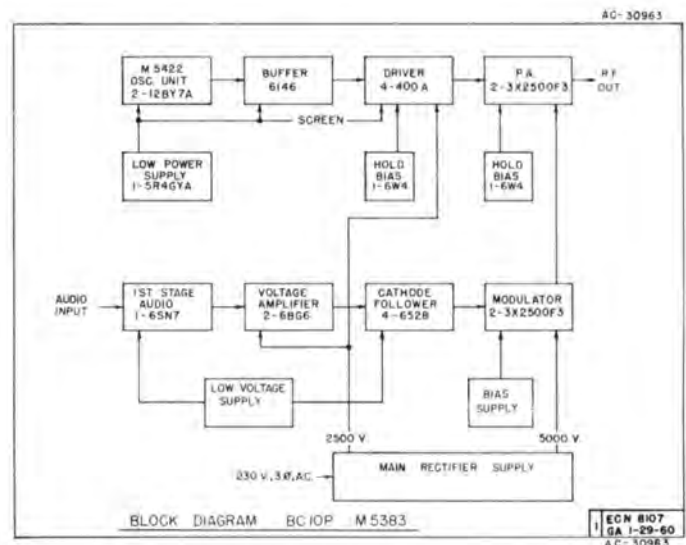

### ORDERING INFORMATION

Model BC-10P, complete with one set of tubes and one crystal. (Tube rectifiers.)

100% set spare tubes

Recommended minimum spare tubes

Model BC-10PS, complete with one set of tubes and one crystal. (Silicon rectifiers.)

100% set spare tubes

Recommended minimum spare tubes

Spare crystal and vacuum holder

M-6064

TK-314

TK-315

M-6079

TK-381

TK-382

A-35177-1

# 5,000 WATT AM BROADCAST TRANSMITTER

## Model BC-5P-2



Conservative design has made the BC-5P-2 an industry standard for 5000 watt AM broadcast service. Designed for both attended and unattended operation, maximum reliability is provided by the use of oversized components, long life tubes and efficient cooling.

The BC-5P-2 is a completely self-contained 5000 watt AM broadcast transmitter with distinctive new styling. Fidelity of the BC-5P-2 extends to 15,000 cycles. Field proven reliability is assured by the performance of over 300 Gates BC-5P series transmitters in service around the world.

**MECHANICAL CONSTRUCTION:** The BC-5P-2 consists of three cubicles which contain as separate units, the RF power section, the modulator/audio section and the control and rectifier section. These cubicles may be placed side by side in any order — at right angles, or installed completely independent of each other — to fit your floor space requirements. Front and rear panels are of the latch-on type and may be removed for easy access. Air filters for each cabinet (bottom rear) are removed for cleaning or replacement

without disrupting the carrier. External cabinetry is 16 gauge furniture grade, cold rolled steel. Internal shields and chambers are of nonferrous metals. There are no external components. The transmitter is 100% self-contained.

**RF POWER SECTION:** Sockets are provided for two vacuum sealed precision crystals. The first (Type 6146) and second (Type 4-250) power amplifiers are tetrode type tubes that do not require neutralization. The Type 3X2500F3 triode final amplifier is neutralized by the standard bridge method. All stages are of standard basic design and proper tuning and adjustment is indicated on self-contained meters.

The final tank and the two-coil "T" output coupling network are edgewound, silver plated, adjustable coils. No variable capacitors are used. The special output circuit design, plus more than adequate shielding, insures operation well within the new FCC specifications on spurious and cabinet radiation. The entire RF section is cooled by a 270 CFM at 1.4" static pressure blower.

**GATES**

## BC-5P-2 5,000 WATT AM BROADCAST TRANSMITTER

## TECHNICAL INFORMATION

**AUDIO SECTION**—All four audio stages are push-pull. The Class B driver uses four 6CA7 tubes in an ultra-linear circuit. The Class B modulator uses two triode 3X2500F3 tubes (interchangeable with final RF amplifier). An overall degenerative feedback circuit from the plates of the modulators to the grids of the input stage further improve the frequency response and distortion characteristics. The low plate impedance of the Class B triode modulators is nearly 1:1 match to the Class C RF load. This, together with special laminations which are the latest development of metallurgical research, result in a compact modulation transformer with improved frequency range and efficiency.

The over-all audio design not only meets or exceeds all standard FCC specifications, it also provides a new low in intermodulation distortion that is readily apparent to the ear in listening tests. The audio cubicle is cooled with a blower identical to that used in the RF section.

**POWER SUPPLIES:** Five power supplies include: (a) Three-phase, full wave, 5000 volt, high voltage supply; (b) Audio driver supply; (c) RF driver supply; (d) Modulator bias supply; (e) RF bias supply.

The transmitter is provided in two models — the M-6061 is supplied with tube rectifiers throughout. (Shown above).

In the M-6062 silicon rectifier model, the 5000 volt high voltage supply has six banks of silicon rectifiers in a full wave configuration. Each bank consists of 25 silicon cells rated at 400 PIV at 18 amperes each. Voltage equalizing resistors and surge suppression capacitors are connected across each cell.

**PROTECTIVE CIRCUITS:** Relays are provided for overload, start/stop and interlock circuits. Air pressure switches replace older damper type.

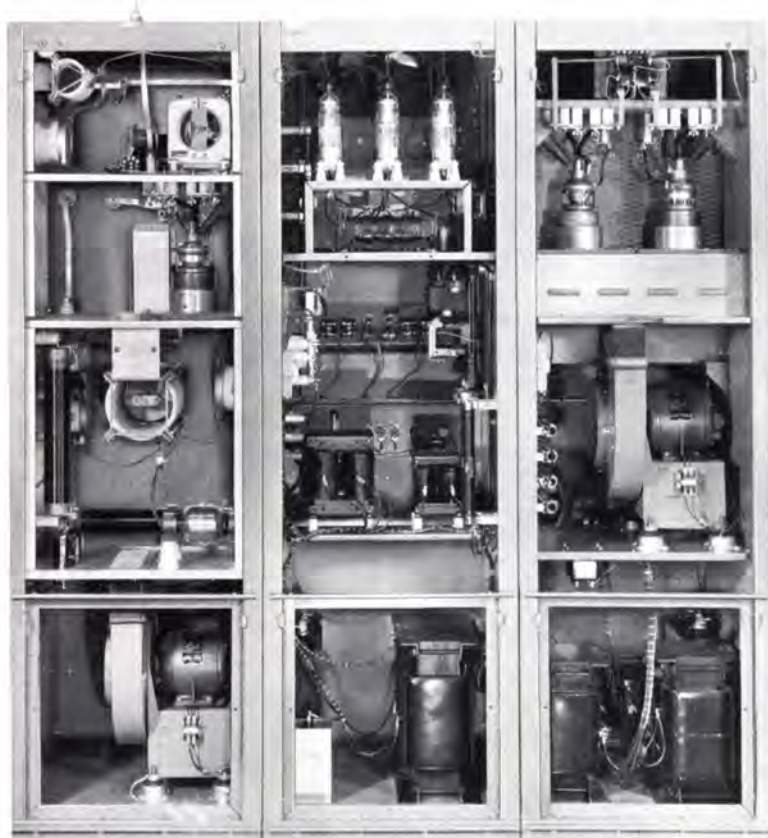

**REMOTE CONTROL:** The exclusive use of relays in the control circuits makes installation of remote control simple. Circuits to be remote controlled are provided with extra terminals.

**RECYCLING:** A unique time-constant circuit replaces the usual stepper relay. This circuit automatically determines the severity of the overload and reacts accordingly. In event of direct short in high voltage supply, the transmitter would recycle once and then shut down. With an occasional flashover, due to a severe electrical storm in the area, the transmitter will momentarily be shut down and then return to the air each time with no mechanical limit on the number of times recycling may occur.

**WIRING:** Trouble shooting and circuit tracing is easy. Every wire is permanently and individually numbered every inch. A GATES exclusive.

# BC-5P-2 5,000 WATT AM BROADCAST TRANSMITTER

## SPECIFICATIONS

### POWER OUTPUT:

Rated 5000 watts, capable 5600 watts.

### POWER REDUCTION:

Carrier reduction to approximately 1 KW.

### AUDIO INPUT:

600/150 ohms. -5 db for 100% modulation ( $\pm 2$  db).

### AUDIO RESPONSE:

$\pm 1\frac{1}{2}$  db, 30-12,000 cycles.

### AUDIO DISTORTION:

3% or less, 50-7500 cycles at 95% modulation.

### NOISE:

60 db or better below 100% modulation at 5 KW power.

### FREQUENCY RANGE:

535-2000 kc (as ordered).

### RF OUTPUT IMPEDANCE:

40-370 ohms (as ordered).

### FREQUENCY STABILITY:

$\pm 5$  cycles.

### MONITORS:

Will accommodate all current models. Gates FCC-approved M-4990 frequency monitor and M-5693 modulation monitor recommended.

### MODULATION AND FREQUENCY MONITOR COUPLING IMPEDANCE:

50/70 ohms.

### MODULATION:

High level plate.

### PRIMARY VOLTAGE:

230 volts, 3-phase, 50/60 cycle delta. (208 volts available on special order.)

### POWER CONSUMPTION:

11.7 KW at zero modulation, 12.9 KW at average modulation, 16.6 KW at 100% modulation.

### CARRIER SHIFT:

3% or less at 100% modulation.

### SIZE:

78" high, 73 $\frac{1}{2}$ " wide, 39 $\frac{1}{2}$ " deep.

### FINISH:

Two-tone medium gloss gray with trim in brushed aluminum and black.

### WEIGHT AND CUBAGE:

Net 2186 lbs., 2970 lbs. packed, 198 cu. ft.

### TUBES:

12BY7 ocs., 12BY7 1st amp., 6146 buffer, 4-250A RF driver, 3X2500F3 power amplifier, 6SN7 1st audio, 6SN7 2nd audio, (4) 6CA7 audio driver, (2) 3X2500F3 modulator, 6W4\* driver hold bias rectifier, 6W4\* PA hold bias rectifier, (2) 5U4G\* audio plate rectifier, 5U4G\* modulator bias rectifier, (6) 8008\* main rectifier.

\*Omitted where silicon dry rectifiers are employed.

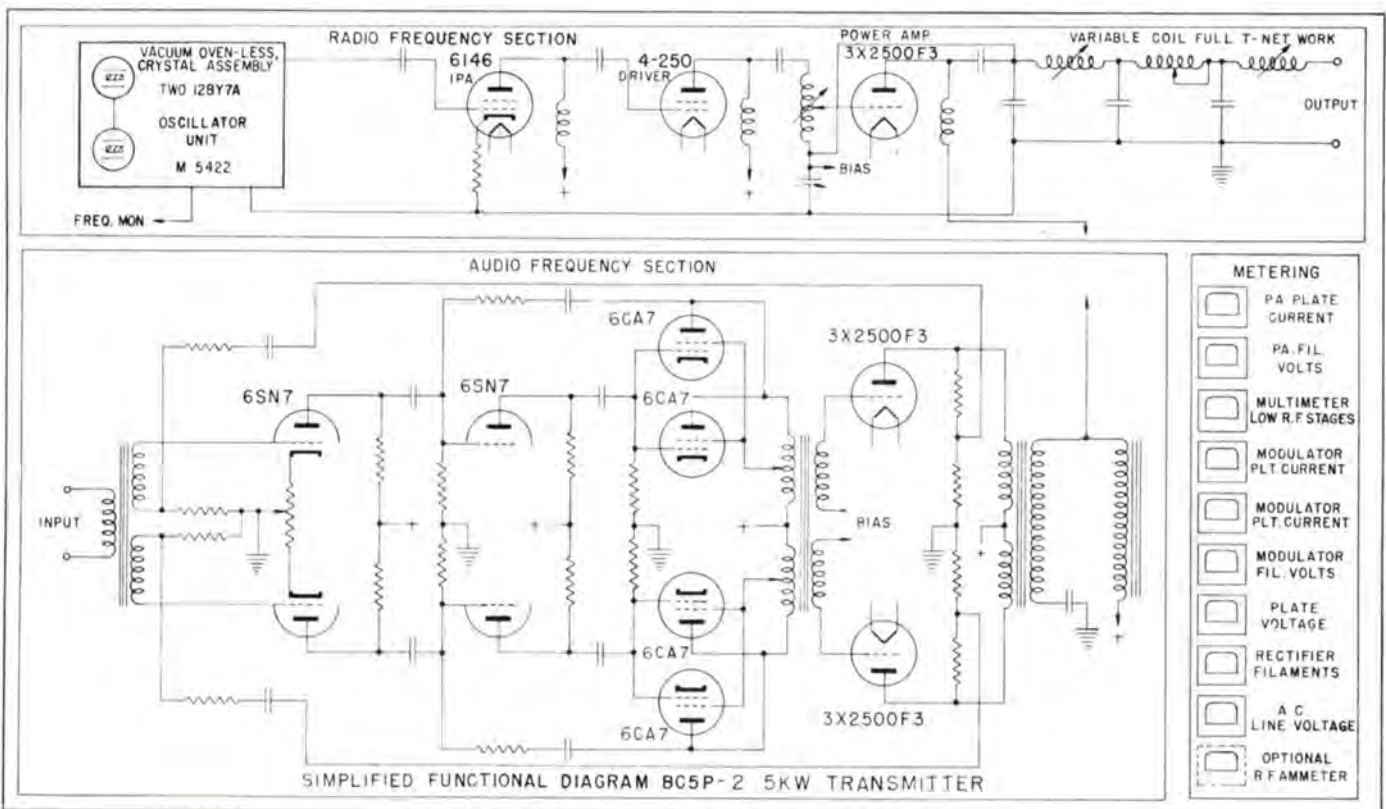

## ORDERING INFORMATION

Model BC-5P-2, complete with one set of tubes and one crystal. (Tube rectifiers.)	M-6061
100% set spare tubes	TK-321
Recommended minimum spare tubes	TK-322
Model BC-5P-2, complete with one set of tubes and one crystal. (Silicon rectifiers.)	M-6062
100% set spare tubes	TK-363
Recommended minimum spare tubes	TK-364
Spare crystal and vacuum holder	A-35177-1



# 1000 WATT AM BROADCAST TRANSMITTER

## Model BC-1G

An unusually rich signal quality that holds listeners to your spot on the dial is standard equipment in the "Big G." Low intermodulation distortion was the objective. The combination of a cathode follower audio driver, an over-all feedback system, low leakage reactance in the modulation transformer and modulating the R.F. driver as well as the power amplifier has resulted in a fidelity of transmission seldom equalled in AM broadcasting equipment.

**GENERAL DESIGN:** The BC-1G 1KW AM broadcast transmitter is completely self-contained in one sturdy steel cabinet 78" high, 37" wide and 29" deep. An attractive front door is hinged on the left and opens to expose all tuning controls. Color-coded switches for Start-Stop and Power Change functions are accessible from the front when the door is closed. These switches illuminate to show the transmitter operating status at a glance. Behind the front door is a full-length perforated grill, interlocked for personnel protection but affording full view of components from top to bottom while the transmitter is operating. This grill may be removed in seconds by means of snap locks. Fast rear access is also achieved by turning two thumb screws to remove the back panel of the transmitter.

A special new feature of the "Big G" is a swing-out vertical panel/shelf assembly which provides a fresh approach to accessibility design. It gives complete access to the low power audio and RF stages, control circuitry, bias supply, filament transformer and relays for the power amplifier and modulator.

**R.F. SECTION:** Dual, vacuum type, ovenless crystal units provide utmost stability. Frequency adjustment and crystal changeover are made from the front as are all transmitter control functions. There are four R.F. stages to assure good frequency stability. Dual long-life 833A tubes feed a generous 1000 watts into a complete Tee network for exact loading and best harmonic attenuation. The final amplifier and Tee network are tuned by variable coils of the large edgewise type, manufactured by Gates.

**AUDIO SECTION:** Wider frequency response, low harmonic and intermodulation distortion and low noise, the basis of the "Big G's" true high fidelity sound, result from a unique circuit arrangement. Intermodulation distortion, an unseen and seldom measured distortion component, when eliminated, provides the difference between ordinary and excellent broadcasting. A new low leakage modulation transformer combined with superb high frequency response has produced typical distortion readings of 1.5% or less at the critical 7000 cycle audio frequency. Push-pull 807 tubes drive the husky push-pull 833A high level modulator tubes, producing an abundance of extra power to provide full performance as tubes age.

**POWER REDUCTION:** Class IV stations will particularly appreciate the quick and efficient way that the "Big G"



reduces power to 250 watts. Switching in the primary of the main plate transformer eliminates power consuming and heat generating voltage dropping resistors. Plate voltage is reduced on both the power amplifier and modulator tubes, resulting in possible hundreds of added tube hours as well as savings in power costs.

**POWER AMPLIFIER TUBES:** In the search for the most reliable power tube, based both on performance and cost per hour, Gates engineers exhaustively tested every FCC-approved tube for this service. The result was the selection of the 833A tube for both R.F. and modulator circuits. The

## MODEL BC-1G 1000 WATT AM BROADCAST TRANSMITTER

833A provides a combined hourly tube cost of approximately 1.3¢ and has nation and world-wide availability. Being a solid husky triode, it is more tolerant to changing operating conditions caused by variances in load or fluctuations in cooling. It was found that this tube resisted spurious emissions and other derelict tube outputs and that it continued to perform excellently even when the cooling system failed. Pressure-type cooling is not required for 833A's.

**REMOTE CONTROL:** Inbuilt metering kits are provided for both plate voltage and plate current. The use of relays throughout rather than circuit breakers permits almost instantaneous adaptation to remote control and eliminates the need for outboard attachments. All electrical connections for remote controlling are brought out to terminal boards. It is only necessary to add a standard, reversible motor assembly for the output power rheostat, for which space and connections have been provided.

**RECTIFIER SYSTEM:** The BC-1G solid state model has three separate power supplies, all with generous size silicon rectifiers, to provide lifetime reliability. In the BC-1G tube rectifier model, 8008 tubes are used for the high voltage supply and 866A tubes for the intermediate supply. Bias supply is silicon.

**COOLING:** A cool operating transmitter is designed from the outset with cooling as a major engineering objective. In the "Big G", parts location is of major importance and is combined with an intelligent convectional cooling system and suction fan ventilation in the top of the cabinet. Fresh air is drawn through dual removable filters at the back base of the transmitter and is circulated through every nook and corner and then exhausted at the top. Heat generating power tubes are located in the direct air stream. Component and tube life are greatly lengthened by the cool-running BC-1G transmitter.



Rear view of the BC-1G transmitter with vertical shelf assembly swung out.

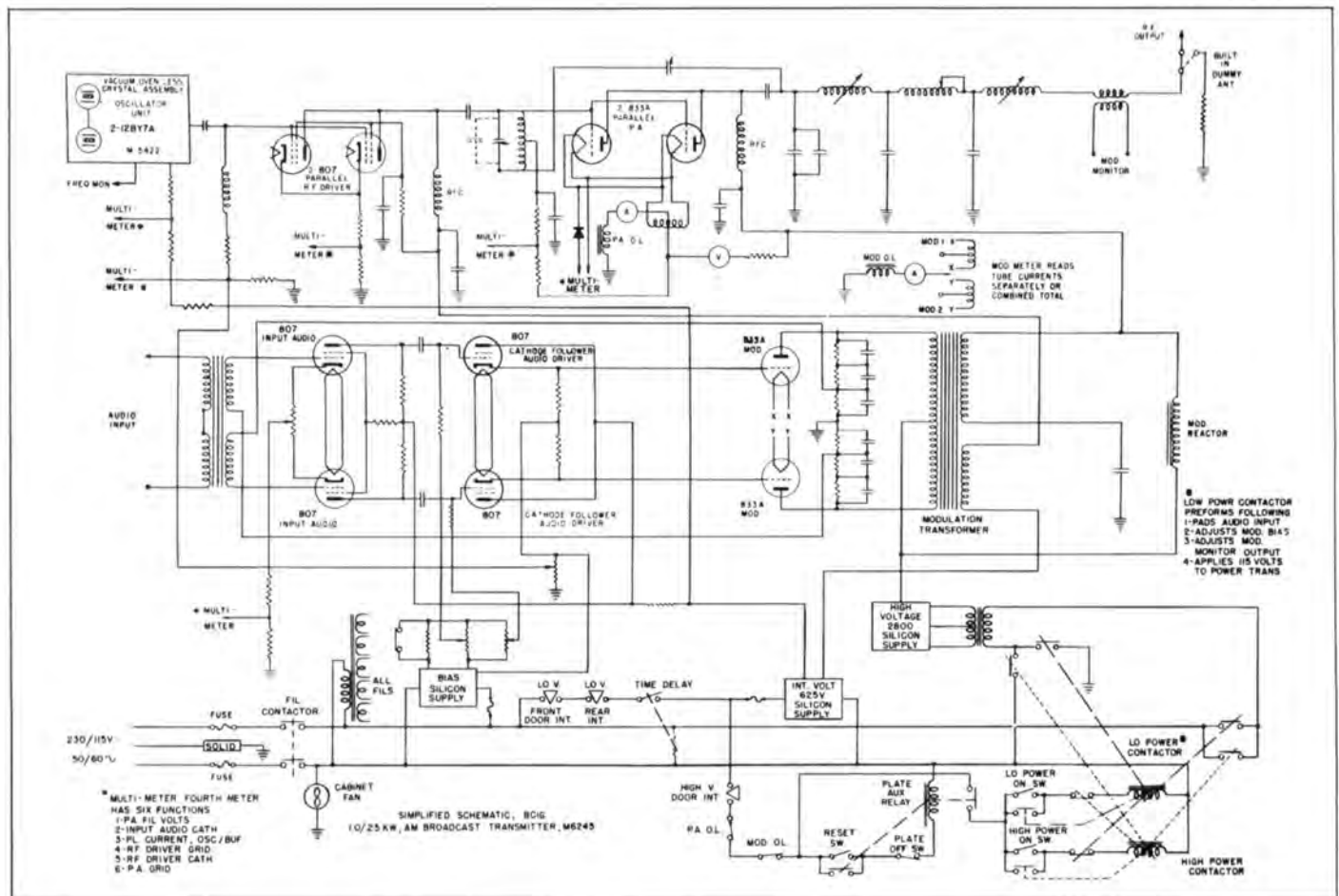



## MODEL BC-1G 1000 WATT AM BROADCAST TRANSMITTER

**MONITORS:** All current makes of frequency and modulation monitors may be accommodated. The modulation monitor is inductively coupled through an ingenious pickup coil while the frequency monitor connects to a low level radio frequency stage. The Gates M-4990 FCC-approved frequency monitor and the Gates M-5693 FCC-approved modulation monitor (patent applied for) are excellent companion units for the new BC-1G transmitter. (See index.)

**RELIABILITY:** A glance at the inside of the "Big G" transmitter tells the story. Reliability comes only through big conservative design. And Gates has it with big transformers that invite 24-hour schedules and the husky, Gates-built, edge-wound tank and Tee network coils. Many Gates transmitters are shipped overseas where 50 cycle power lines prevail. The BC-1G transmitter is designed for both 50 and 60 cycles and automatically provides a 20% bonus safety factor for 60 cycle users.

### SPECIFICATIONS

**POWER OUTPUT:**

FCC-rated 1000/500/250 watts. Maximum capacity to accommodate phasor loss, 1100 watts. Power reduction 1000/250 watts standard equipment.

**AUDIO INPUT:**

150 or 600 ohms at  $\pm 16$  db.  $\pm 2$  db.

**AUDIO RESPONSE:**

Under practical programming conditions,  $\pm 1.5$  db. 30-16,000 cycles. Rated  $\pm 1.5$  db. 30-12,000 cycles.

**AUDIO DISTORTION:**

Under practical programming conditions, 2% 50-16,000 cycles. Rated 3% or less 50-10,000 cycles.

**NOISE: (unweighted)**

At 1000 watts, 60 db or better below 100% modulation.  
At 250 watts, 55 db or better below 100% modulation.

**FREQUENCY RANGE:**

540-2000 KC as ordered.

**R.F. OUTPUT IMPEDANCE:**

50/70 ohms.

**FREQUENCY STABILITY:**

$\pm 5$  cycles or better.

**MONITORS:**

Will accommodate all current models. Gates FCC-approved M4990 frequency monitor and M5693 modulation monitor recommended.

**MODULATION:**

High Level Class B.

**PRIMARY VOLTAGE:**

230 volts, 3 wire, 50/60 cycles single phase. (208 volts also available where specified).

**\*POWER CONSUMPTION:**

1 KW; no modulation, 2650 watts; average modulation, 3150 watts; 100% modulation, 3850 watts.  
250 watts; no modulation, 1650 watts; average modulation, 1825 watts; 100% modulation, 2050 watts.

**CARRIER SHIFT:**

Rated 3% or less. Typical with adequate power mains is 2%.

**DUMMY ANTENNA:**

51 $\frac{1}{2}$  ohms for full 100% modulation.

**SIZE:**

78" high, 37" wide, 29" deep. Front door swing, 32".

**FINISH:**

Two tone medium gloss gray with trim in brushed aluminum and black.

**\*WEIGHT:**

Net 1000 lbs. Domestic packed, 1140 lbs. Export packed, 1490 lbs. Cubage 110.

**\*TUBES:**

Model M6245 solid state rectifier model  
(2) 12BY7A, (6) 807, (4) 833A.  
Total tube types, 3. Total tubes, 12.

\*Power consumption for the BC-1G transmitter with rectifier tubes is slightly higher than stated in the specifications due to the addition of filament transformers. Likewise, packed weight is increased by approximately 25 lbs. Tube rectifier model M-6245B includes 2 type 8008 and 2 type 866A tubes. All other specifications are the same for both models.

### ORDERING INFORMATION

BC-1G transmitter for 1000/250 watts complete with tubes, one crystal, dummy antenna and silicon rectifiers	M6245
BC-1G transmitter for 1000/250 watts complete with tubes, one crystal, dummy antenna and tube rectifiers	M6245B
Extra crystal and vacuum holder	M5602
100% spare tube complement for BC-1G (silicon rectifiers)	TK-471
100% spare tube complement for BC-1G (tube rectifiers)	TK-472

**NOTE:** Where 208 volts is required instead of 230 volts, be sure and specify when ordering. Otherwise, 230 volt model will be supplied.

# 500 WATT AM BROADCAST TRANSMITTER

## Model BC-500G



The BC-500G, 500 watt AM transmitter is essentially the same as the BC-1G, 1000 watt model. It consists of 4 RF stages with provision for two vacuum type crystal units of extreme stability. Following the 807 drivers, a simple type 833A final amplifier feeds a full "T" network for maximum harmonic attenuation. The final amplifier and "T" network are tuned by variable edgewise wound coils for exact tuning, loading and reliability.

The audio section consists of 3 stages all push-pull. The cathode follower audio driver stage utilizes dual 807 tubes. A pair of long life Type 833A tubes are used as modulators. For superb high frequency performance, a specially developed modulation transformer incorporates two secondary windings, one of which is used for partially modulating the RF driver. Power increase to 1000 watts may be accomplished by field installation of a conversion kit.

OFF AIR TESTING provided. The inbuilt dummy antenna has capability of handling 500 watt carrier, 100% modulated.

PERFORMANCE: The owner of the BC-500G has an ultraconservative transmitter, when considering the fact that the basic 1KW design is followed. Tube life, especially that of the type 833A power amplifier and modulator tube, is extremely gratifying.

(As the basic description of the BC-500G transmitter is the same as Model BC-1G, the following specifications cover information pertinent to the BC-500G. For all other descriptive data the reader is referred to Model BC-1G.)

### SPECIFICATIONS

#### POWER OUTPUT:

FCC rated 500 watts. Capability 550 watts. Also capable of 100 watt operation.

#### AUDIO INPUT:

150 or 600 ohms.  $\pm 9$  db  $\pm 2$  db for 100% modulation at impedance choice.

#### AUDIO RESPONSE:

$\pm 1\frac{1}{2}$  db 30-12,000 cycles. (Typical:  $\pm 1\frac{1}{2}$  db 30-16,000 cycles under practical programming conditions.)

#### AUDIO DISTORTION:

3% or less 50-10,000 cycles at 95% modulation.

#### NOISE:

60 db, or better, below 100% modulation level.

#### FREQUENCY RANGE:

540 Kc to 2000 Kc (as ordered).

#### RF OUTPUT IMPEDANCE:

50/70 ohms.

#### FREQUENCY STABILITY:

$\pm 5$  cycles.

#### MONITORS:

Will accommodate all current models. Gates FCC-approved M4990 frequency monitor and M-5693 modulation monitor recommended.

#### MODULATION:

High level, Class B.

#### PRIMARY VOLTAGE:

230 volts, 3 wire, 50/60 cycles single phase. 208 volts available on special order.

#### POWER CONSUMPTION:\*

1900 watts at zero modulation, 2200 watts at average modulation, 2600 watts at 100% modulation.

#### CARRIER SHIFT:

3% or less at 100% modulation.

#### DUMMY ANTENNA:

51 $\frac{1}{2}$  ohms.

#### SIZE:

78" high, 37" wide, 29" deep. Front door swing 32".

#### FINISH:

Two tone medium gloss gray with trim in brushed aluminum and black.

#### WEIGHT AND CUBAGE:

Domestic — 950 lbs. net, 1100 lbs. packed. 100 cu. ft.

#### TUBES:

12BY7A oscillator, 12BY7A 1st IPA, (2) 807 2nd IPA, (1) 833A power amplifier (2) 807 1st audio, (2) 807 2nd audio, (2) 833A modulators. Silicon powered — M-6333. M-6333B — using tube rectifiers, (2) 8008, (2) 866A (additional tubes).

\*Slightly higher if tube rectifiers used.

### ORDERING INFORMATION

Model BC-500G AM broadcast transmitter, 500 watts,  
with tubes, one crystal, silicon rectifiers\*  
Spare 100% tube complement for BC-500G

M-6333  
TK-481

Recommended minimum spare tube kit for BC-500G

TK-479

\*Tube rectifiers optional.

**GATES**

# 250 WATT AM BROADCAST TRANSMITTER

## Model BC-250GY



Fully FCC type approved, the Gates BC-250GY is the most widely used 250 watt AM broadcast transmitter and has a world-wide reputation for long trouble-free service. It consists of three audio frequency stages with provision for 2 crystals in temperature controlled ovens. The Type 813 RF driver provides an abundance of drive and long tube life. A pair of Type 810 single ended power amplifiers feed an output coupling network that will match specified impedances from 30 to 300 ohms.

In the audio frequency section, two audio stages consist of push-pull 6L6's driving two 810 tubes operating as Class B high frequency modulators. The BC-250GY provides complete metering with 8 meters—more than any other 250 watt broadcast transmitter. Quiet operation is assured as the large roomy design allows convection cooling without the necessity of blowers or fans.

Vertical construction is employed throughout permitting walk-in service. The audio deck is hinged for quick accessibility. As an additional bonus, all transformers are 50/60 cycle design for added reliability.

The BC-250GY is designed to provide low distortion and noise, wide frequency response and excellent stability for superb broadcast service.

### SPECIFICATIONS

#### POWER OUTPUT:

Rated 250 watts, capability 280 watts.

#### AUDIO INPUT:

600 ohms  $\pm 14$  db  $\pm 2$  db.

#### AUDIO RESPONSE:

90% modulation 1  $\pm 1\frac{1}{2}$  db. 30-10,000 cycles,  $\pm 2$  db.  
30-12,000 cps.

#### AUDIO DISTORTION:

3% or less 50-7500 cps at 90% modulation.

#### FREQUENCY RANGE:

540-1600 Kc (as ordered).

#### RF OUTPUT IMPEDANCE:

30-300 ohms (as ordered).

#### FREQUENCY STABILITY:

$\pm 5$  cycles.

#### MONITORS:

Will accommodate all current models. Gates FCC-approved M-4990 frequency monitor and M-5693 modulation monitor recommended.

#### MODULATION:

High level plate.

#### PRIMARY VOLTAGE:

230 volts, 2 wire, 50/60 cycles.

#### POWER CONSUMPTION:

1.6 Kw at 95% modulation.

#### CARRIER SHIFT:

3% or less at 95% modulation.

#### SIZE:

78" high, 34" wide, 33" deep.

#### FINISH:

Gloss gray and black.

#### WEIGHT AND CUBAGE:

900 lbs. packed, 112 cubic feet.

#### TUBES:

807 oscillator, 813 IPA, (2) 810 power amplifiers, (2) 6L6 (1622) audio drivers, (2) 810 class B modulators, (2) 8008 rectifiers and 5Y4G rectifier.

### ORDERING INFORMATION

250 Watt Broadcast Transmitter with one set tubes, crystal and oven

BC-250GY

Spare 100% tube complement for BC-250GY

M-3074

Recommended minimum tube complement for B-250GY

TK-487

Extra crystal and oven for BC-250GY

JK-57M

# 20,000 WATT FM BROADCAST TRANSMITTER

## Model FM-20B

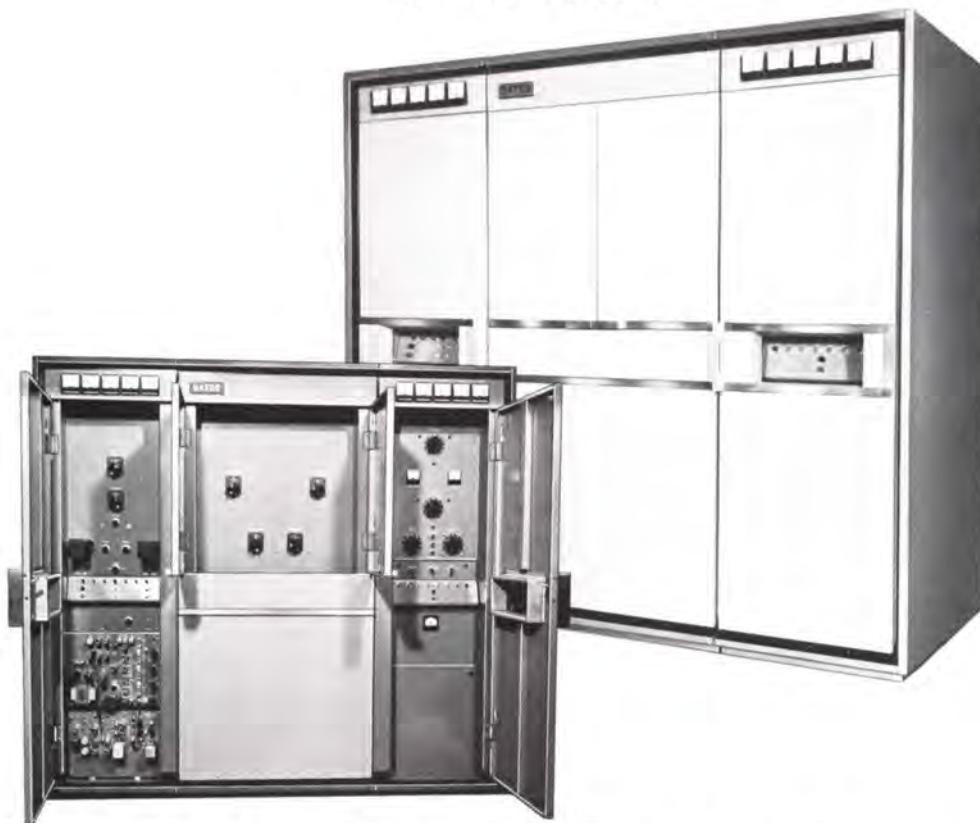

**DESIGNED FOR 20 KILOWATTS**—Gates engineering objective for the FM-20B was to design a completely self-contained 20-KW transmitter. The result is broadcasting's most compact 20 kilowatt FM transmitter with many inherent advantages in its design. As there is only one amplifier for 20 kilowatts output, installation is simplified and valuable floor space is saved. No diplexer is necessary, and only one  $6\frac{1}{8}$ " harmonic filter and one internal plate transformer is required.

**CASCADE EXCITER — STEREO — MONAURAL** — Gates new FM "cascade" exciter is the heart of the quality FM sound. It incorporates the feature of direct crystal control to produce a wonderful high fidelity signal. This FM exciter, with its full response from 30 to 15,000 cycles, is included as standard equipment on all Gates FM transmitters. (Stereo generator pictured is optional.)

**SIMPLIFIED TUNING**—As opposed to "dual transmitter" operation, tuning Gates FM-20B transmitter is greatly simplified. The 20-KW power amplifier uses two 4CX10,000D power tetrode tubes, operated in a push-pull grounded cathode circuit. The power amplifier plate circuit consists of a distributed shorted  $\frac{1}{4}$  wavelength line which is tuned by changing the electrical length of the line. RF output coupling is an inductively coupled balun, which is mounted in the power amplifier enclosure. Output loading is adjusted with a variable vacuum capacitor.

**CONSTRUCTION**—The complete FM-20B transmitter is housed in three cubicles and is only 87 inches wide. The

left cubicle includes the new "cascade" FM exciter, the primary control system, a 50 watt intermediate power amplifier, the 1-KW driver and its power supply and cooling system. The center cubicle contains the power amplifier enclosure with two 4CX10,000D tetrode tubes, a low-noise high capacity cooling system, the PA filament transformer and a motor driven variable transformer for the driver plate transformer. The right cubicle houses the power supply and control circuits for the 20-KW amplifier. It also contains the relay equipment for the start-stop functions of the amplifier, other overload and undercurrent relays, and safety protection equipment.

Complete metering is provided with thirteen separate meters on the FM-20B transmitter for: filament voltage, control grid current, screen grid currents, plate current, plate voltage and power output/VSWR. The right cubicle also contains meters on the front panel for screen voltage, grid voltage and total elapsed time.

Automatic recycling is standard in the FM-20B Transmitter and all wiring for remote control is built-in and terminated.

**SILICON RECTIFIERS**—There are four power supplies, (a) 1KW P.A. (b) P.A. screen (c) P.A. bias, and (d) 20,000 watt P.A. plate, which are all silicon, solid state diodes. The high voltage supplies have a 3 to 1 current safety factor and approximately a 2 to 1 voltage safety factor.

**GATES**

# 20,000 WATT FM BROADCAST TRANSMITTER

## SPECIFICATIONS

- POWER OUTPUT:**  
20,000 watts, capable 21,000 watts.
- FREQUENCY RANGE:**  
88 to 108 mcs.
- RF OUTPUT IMPEDANCE:**  
50.0 ohms.
- FREQUENCY STABILITY:**  
±.001%.
- TYPE OF MODULATION:**  
Phase shift employing pulse techniques.
- MODULATION CAPABILITY:**  
±100 Kc.
- AUDIO INPUT IMPEDANCE:**  
600 ohms.
- AUDIO INPUT LEVEL:**  
+10 dbm, ±2 db.
- FREQUENCY RESPONSE:**  
±1 db 50-15,000 cycles. -2 db 30 cycles.
- DISTORTION:**  
1% or less 30-15,000 cycles.  
1/2% or less 100-10,000 cycles.
- NOISE:**  
65 db below 100% modulation (FM) 50 db below equivalent 100% (AM) mod.
- POWER INPUT:**  
20-KW Amplifier: 208/240 volts 50/60 cps. 3 phase.  
Driver: 208/240 50/60 cps. 1 phase grounded and neutral.
- TUBE COMPLEMENT:**
- |           |                |
|-----------|----------------|
| (3) 6201  | (1) 6080       |
| (7) 6AU6  | (1) 6360       |
| (1) 6AQ5  | (2) 6146       |
| (3) 6J6   | (3) 7025       |
| (1) 12AX7 | (2) 4-400A     |
| (2) OA2   | (2) 4CX10,000D |
- POWER SUPPLIES:**  
Silicon rectifiers.
- MAX. ALTITUDE:**  
7,500 feet.

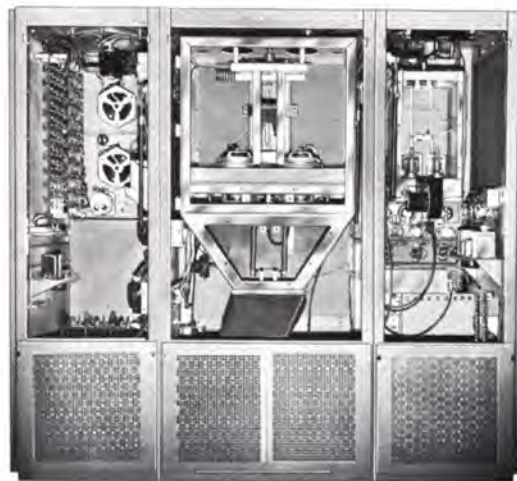

- MAX. AMBIENT:**  
-20° to 45° C.
- RF HARMONICS:**  
80 db or better.
- POWER CONSUMPTION:**  
35 KW (approx.) at 0.9 power factor.
- MAXIMUM VSWR OF LOAD:**  
1.7 to 1 max.
- TOTAL NUMBER OF TUBES:**  
28.
- TOTAL TUBE TYPES:**  
12.
- SIZE:**  
87" wide, 78" high, 36 1/2" deep. Front door swing, 21".
- WEIGHT:**  
2600 lbs. (approx.) net, 3200 lbs. (approx.) packed.
- FINISH:**  
Two-tone gray with black accent. Brushed aluminum trim.

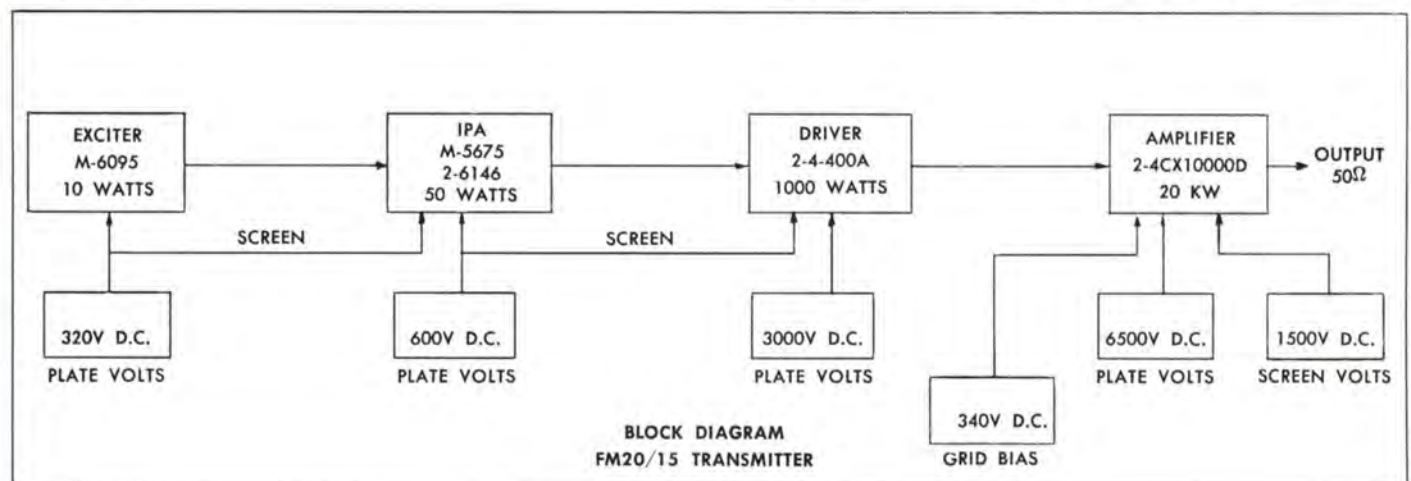

## ORDERING INFORMATION

FM-20B, 20,000 Watt FM Transmitter with tubes, crystal and oven  
 100% Tube Kit for FM-20B  
 FCC Tube Kit for FM-20B

M-6045  
 TK-393  
 TK-394

# 10,000 WATT FM BROADCAST TRANSMITTER

## Model FM-10B

**CONSTRUCTION AND DESIGN:** The FM-10B transmitter is housed in two cubicles only 50 inches wide. The left cubicle is a complete 250 watt FM transmitter and houses the new "cascade" FM exciter, primary control system, the driver, and its power supply. Also included are the high voltage transformer and reactor for the power amplifier. The right cubicle is the 10-KW amplifier, complete with its control circuitry. The right cubicle is independent of the 250 watt driver section with the exception of the control circuitry. The FM-10B transmitter is wired for remote control with all remote control accessories built in. Automatic recycling is also standard in the FM-10B.

Accessibility is a major design feature. Fast and easy access to all components is accomplished with drop-down control panels, lift-off doors and swing-out panels.

**VARIA-LINE POWER TANK:** Varia-Line tuning is an exclusive Gates feature. The power amplifier plate is inductively tuned, and since it is series fed there are no mica blocking capacitors to heat in case of changing VSWR. As a distributive type tank circuit replaces the commonly used shunt fed lumped constant circuit, tuning over the entire 88-108 MC band is possible without component change.

**POWER AMPLIFIER STAGES:** Approximately 5 watts are required from the exciter to drive the 4CX250B driver stage. This supplies a nominal 250 watts to drive the single ended 4CX10,000D power tetrode to a full 10 kilowatts output.

**SOLID STATE POWER SUPPLIES:** The solid state power supplies for 250 watts I.P.A., P.A. screen, P.A. bias, and 10,000 watt P.A. plate, all use silicon diodes. The high voltage supplies have a 10 to 1 current safety factor and a 2 to 1 voltage safety factor. The main power supply develops 6500 volts from a 3-phase full wave rectifier supply. The silicon rectifiers offer greatly improved performance as they are particularly resistant to aging, moisture and wide temperature variations. A heavy design silicon power supply for screen voltage to the power amplifier tubes and 4CX250B plate voltage is incorporated for added stability.

**PERFORMANCE:** The operating characteristics of the FM-10B transmitter exceed those required by the FCC for standard FM broadcast service. One percent distortion and lower is characteristic between 30 cycles and 15,000 cycles, with readings of  $1/2\%$  distortion between 100 and 10,000



Front view of transmitter shows complete accessibility. Panel in lower left cubicle provides mounting space for Gates M-6146 stereo generator.

cycles. The FM-10B transmitter tunes the complete FM broadcast band of 88 to 108 megacycles by simply changing the crystal and retuning.

The transmitter is designed to operate from either 208 volts or 230 volt 3 phase, 50/60 cycle power supply. A VSWR output meter indicates power output directly in watts and standing wave ratio.

**GATES**

# MODEL FM-10B 10,000 WATT FM BROADCAST TRANSMITTER

## SPECIFICATIONS

**POWER OUTPUT:**  
10,000 Watts, capable 11,000 Watts.

**FREQUENCY RANGE:**  
88 to 108 Mcs.

**RF OUTPUT IMPEDANCE:**  
50.0 ohms.

**FREQUENCY STABILITY:**  
±.001%.

**TYPE OF MODULATION:**  
Phase shift employing pulse techniques, using the new exclusive Gates cascade circuit.

**MODULATION CAPABILITY:**  
±100 Kc.

**AUDIO INPUT IMPEDANCE:**  
600 ohms.

**AUDIO INPUT LEVEL:**  
+10 dbm, ±2 db.

**FREQUENCY RESPONSE:**  
±1 db. 50-15,000 cycles.  
-2 db. 30 cycles.

**DISTORTION:**  
1% or less 30-15,000 cycles.  
1/2% or less 100-10,000 cycles.

**NOISE:**  
65 db below 100% modulation (FM).  
50 db below equivalent 100% (AM) Mod.

**POWER INPUT:**  
208/240 volts, 50/60 cycles, 3 phase, 18,500 watts (approx.) at 90% power factor.  
117 volts, 50/60 cycles, 1 phase 1,000 watts (approx.) at 90% power factor.

**TUBE COMPLEMENT:**

<b>Exciter</b>	1 — 6360
	7 — 6AU6
	1 — 12AX7
	3 — 6J6
	2 — 0A2
	1 — 6AQ5
	1 — 6080
<b>IPA</b>	1 — 4CX250B
<b>PA</b>	1 — 4CX10,000D

**POWER SUPPLIES:**  
Silicon rectifiers.

**MAX. ALTITUDE:**  
10,000 feet.

**MAX. AMBIENT:**  
-20° to 45°C.

**MAX. VSWR OF LOAD:**  
1.7 to 1 Max.

**SIZE:**  
50" wide, 78" high, 38 1/2" deep; 21" front door swing.

**WEIGHT AND CUBAGE:**  
Packaged 2475 lbs. approx. Net 1900 lbs. approx.  
78 cu. ft. unpacked.

**FINISH:**  
Two tone gray with black Shadow Mold accent.  
Brushed aluminum trim.

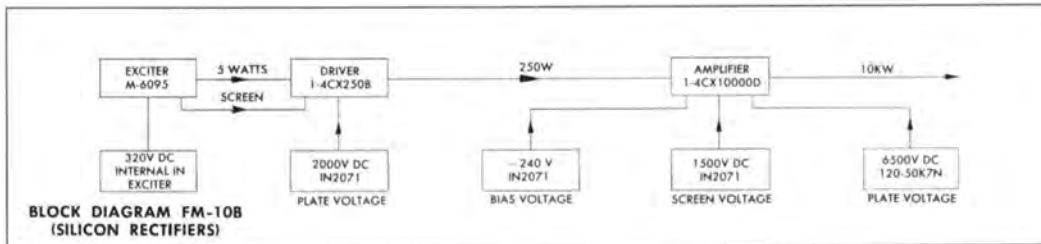
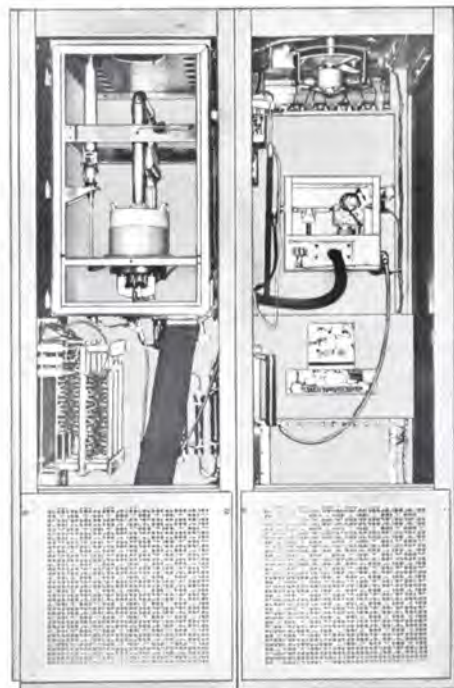

## ORDERING INFORMATION

FM-10B 10-KW FM TRANSMITTER with silicon rectifiers .....	M-6154
100% spare tubes for FM-10B .....	TK-401
Mfg. recommended minimum tube kit for FM-10B .....	TK-467
FM-10B 10-KW FM TRANSMITTER with tube rectifiers .....	M-6098
100% spare tubes for FM-10B .....	TK-395
Mfg. recommended minimum tube kit for FM-10B .....	TK-466

# 5000 WATT AND 7500 WATT FM BROADCAST TRANSMITTERS

## Models FM-5C and FM-7.5B

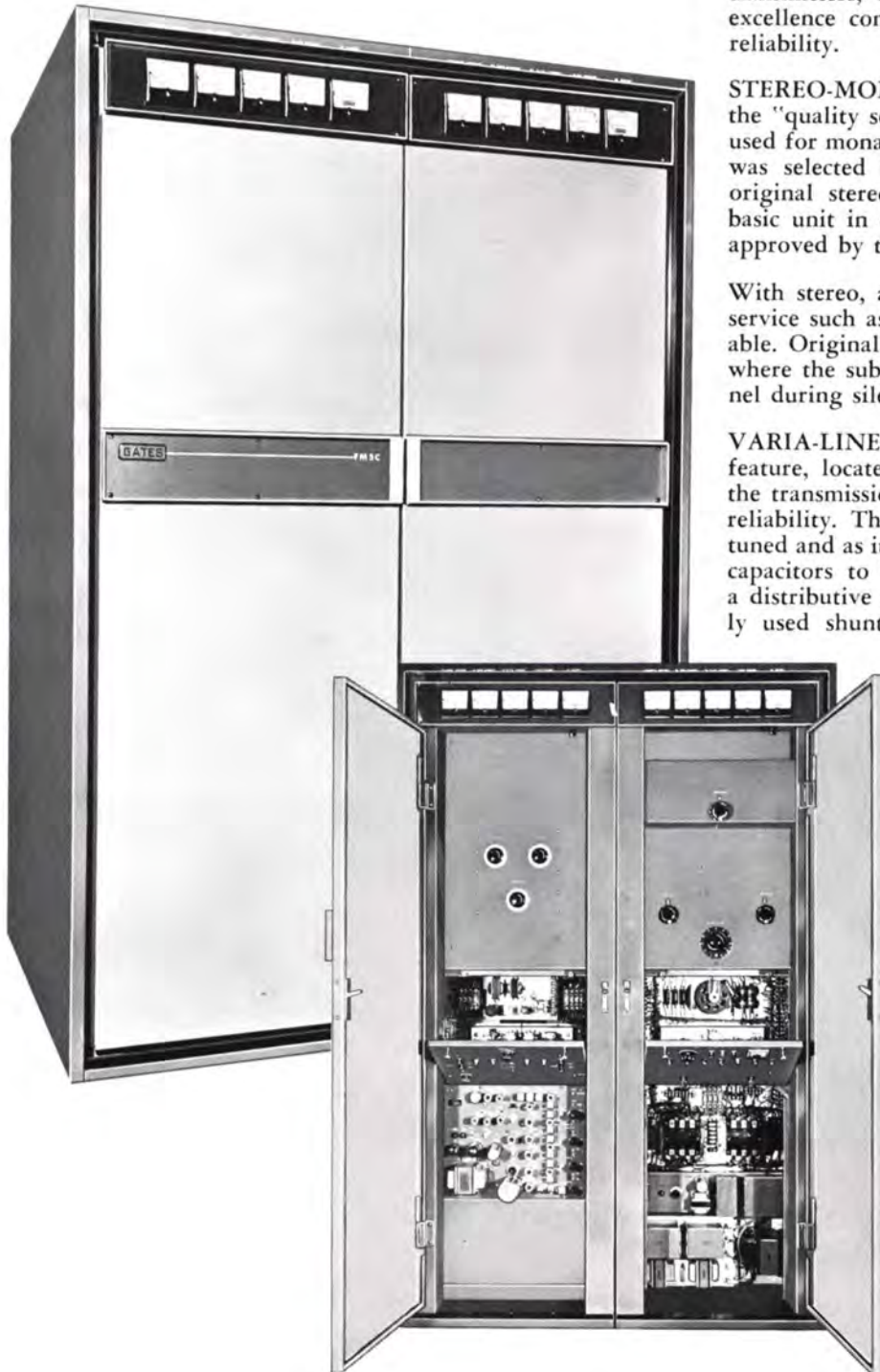

In the new FM-5C 5000 watt and FM-7.5B 7500 watt transmitters, Gates offers the very finest in technical excellence combined with styling, serviceability and reliability.

**STEREO-MONAUURAL-MULTIPLEXING:** Heart of the "quality sound" is the new FM "cascade" exciter used for monaural or with the stereo generator. Gates was selected by several receiver manufacturers for original stereo research and a Gates exciter was a basic unit in one of the two stereo systems initially approved by the FCC.

With stereo, an added sub-channel for multiplexing service such as subscription music is optionally available. Original in Gates design is the automatic mute where the sub-channel is muted from the main channel during silent periods.

**VARIA-LINE POWER TANK:** This exclusive Gates feature, located where output power is delivered to the transmission line, adds to efficiency, stability and reliability. The power amplifier plate is inductively tuned and as it is series fed there are no mica blocking capacitors to heat in case of changing VSWR. As a distributive type tank circuit replaces the common-

ly used shunt fed lumped constant circuit, tuning over the entire 88-108 MC band is possible without component change. The efficiency and stability of the power tank is particularly important in stereo and multiplexing as related to crosstalk and phase control. Gates *Varia-Line* is outstandingly effective in this area and is *exclusively* Gates.

**CONSTRUCTION AND DESIGN:** The FM-5C, 5-KW and FM-7.5B, 7.5-KW transmitters are contained in two cubicles. The left cubicle is a 250 watt driver coupled at low impedance (50 ohms) to the 5-KW or 7.5-KW power amplifier. Components in the left cubicle consist of the 10 watt exciter, primary control system and the (4CX250B) driver. It also contains the high voltage transformer and reactor for the power amplifier. Blank space is provided for the addition of multiplexing and FM stereo generating equipment. The right cubicle is the 5 or 7.5

**GATES**



## 5000 WATT AND 7500 WATT FM BROADCAST TRANSMITTERS

kilowatt amplifier and houses the power amplifier (4CX5,000A tube), its control circuitry, relay equipment, overload, undercurrent and safety protection devices and a new *low noise cooling system*.

Accessibility is a major construction feature of Gates new FM line. Ready access to all components is accomplished with the use of drop-down control panels, lift-off doors and swing-out panels. The back view emphasizes how components have been placed for ease of maintenance. Protection of personnel from electrical shock is provided by door interlock switches.

**INTERMEDIATE AND POWER AMPLIFIER STAGES:** From exciter output to transmission line at 5000 or 7500 watts there are only two radio frequency stages. The reduction of frequency multiplication after the exciter helps to eliminate spurious frequencies and further extends tube life, as power type tubes doubling or tripling frequency will consume greater input power resulting in short tube life.

Approximately 5 watts are required from the exciter to drive the 4CX250B driver stage. This supplies a nominal 250 watts to drive the 4CX5000A power tetrode. This power tetrode is used as a single ended amplifier to produce a liberal 5 or 7.5 kilowatt of power. As this stage operates the tube well under its maximum ratings, even at a full 7.5-KW output, tube life is greatly increased.

**SOLID STATE POWER SUPPLIES:** The power supplies for P.A. screen, P.A. bias and 5000 or 7500 watt P.A. plate, are all silicon diodes. The main power supply develops 5000 volts from a 3 phase full wave rectifier supply. Silicon rectifiers offer greatly improved performance since they are largely resistant to aging, moisture and wide temperature variations.

**AUTOMATIC RECYCLING:** Often not standard in transmitters of this power range, Gates has incorporated automatic recycling, where in case of momentary overload, the transmitter is again turned on. Where the overload presents itself three consecutive times, the transmitter will then remain off until it is manually reset, either locally or by remote control.

**REMOTE CONTROL:** All wiring for remote control is built in and terminated. Relays are used in all circuits such as filament "start-stop," plate "start-stop," etc. No circuit breakers are used in a mandatory operating function and therefore no modifications or additional relay kits are necessary when remote control is added.

**PERFORMANCE AND OTHER FEATURES:** The operating characteristics of the new FM-5C and FM-7.5B exceed those required by the FCC for standard FM broadcast service. One per cent distortion and lower is characteristic between 30 cycles and at 15,000 cycles, with readings of  $\frac{1}{2}\%$  normal in the range between 100 and 10,000 cycles. The FM-5C and FM-7.5B tune the complete FM broadcast band of 88 to 108 megacycles by changing the crystal and retuning.

The transmitter is designed to operate from either 208 volt/230 volt, 50/60 cycle 3 phase power supply. A VSWR output meter indicates both power output directly in watts and standing wave ratio.



Rear view of Gates FM-5C and 7.5B.

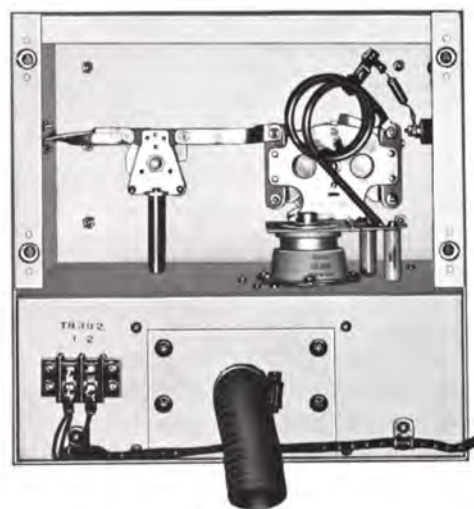

Close-up view of 250 watt driver for the FM-5C and 7.5B.

# 5000 WATT AND 7500 WATT FM BROADCAST TRANSMITTERS

## SPECIFICATIONS

	FM-5C	FM-7.5B		FM-5C	FM-7.5B
<b>POWER OUTPUT:</b>	5,000 Watts.	7,500 Watts.	<b>TUBE COMPLEMENT:</b>	(7) 6AU6 (1) 12AX7 (3) 6J6 (2) 0A2 (1) 6AQ5 (1) 6080 (1) 6360 (1) 4CX250B (1) 4CX5,000A (3) 6201 (3) 7025 (1) 5AR4/GZ-30	
<b>FREQUENCY RANGE:</b>	88 to 108 mcs.		<b>POWER SUPPLIES:</b>	Silicon rectifiers.	
<b>RF OUTPUT IMPEDANCE:</b>	50.0 ohms.		<b>MAX. ALTITUDE:</b>	10,000 feet.	
<b>FREQUENCY STABILITY:</b>	±.001%.		<b>MAX. AMBIENT:</b>	-20° to 45° C.	
<b>TYPE OF MODULATION:</b>	Phase shift employing pulse techniques.		<b>MAX. VSWR OF LOAD:</b>	1.7 to 1 Max.	
<b>MODULATION CAPABILITY:</b>	±100 Kc.		<b>SIZE:</b>	Width 50", Height 78" Depth 38 1/2".	
<b>AUDIO INPUT IMPEDANCE:</b>	600 ohms.		<b>FRONT DOOR SWING:</b>	21".	
<b>AUDIO INPUT LEVEL:</b>	+10 dbm, ±2 db.		<b>WEIGHT:</b>	Packed 2475 lbs. approx., Net 1900 lbs. approx.	
<b>FREQUENCY RESPONSE:</b>	±1 db. 50-15,000 cycles. -2 db. 30 cycles.		<b>FINISH:</b>	Two-tone gray with black accent. Brushed aluminum trim.	
<b>DISTORTION:</b>	1% or less 30-15,000 cycles. 1/2% or less 100-10,000 cycles.		<b>CUBAGE:</b>	78 cu. ft. unpacked.	
<b>NOISE:</b>	65 db below 100% modulation (FM) 50 db below equivalent 100% (AM) Mod.				
<b>POWER INPUT:</b>	208/240 volts, 50/60 cycles, 3 phase, 9,250 watts (approx.) at 90% power factor.	208/240 volts, 50/60 cycles, 3 phase, 13,500 watts (approx.) at 90% power factor.			

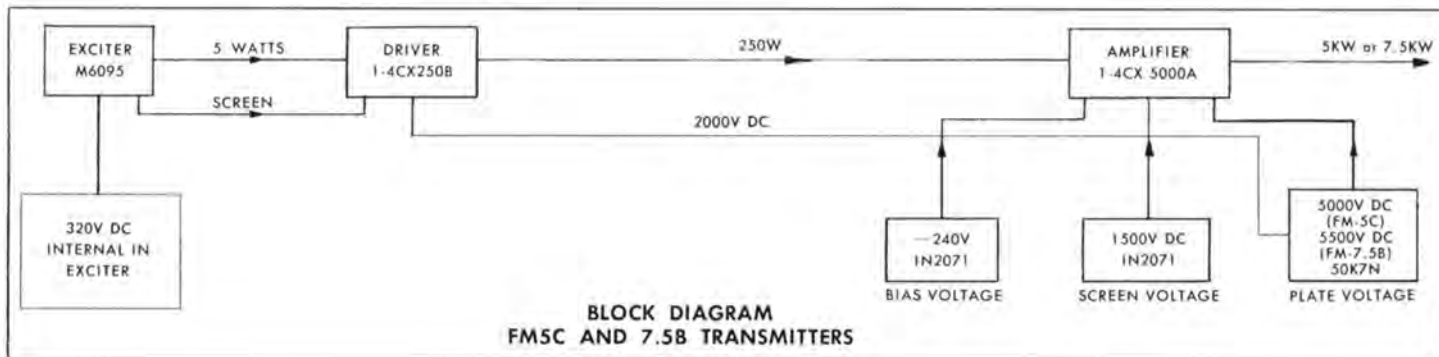

## ORDERING INFORMATION

<b>FM-5C, 5-KW FM TRANSMITTER with silicon rectifiers</b>	<b>M-6156</b>	<b>FM-7.5B, 7.5-KW FM TRANSMITTER with silicon rectifiers</b>	<b>M-6155</b>
100% spare tubes for FM-5C	TK-408	100% spare tubes for FM-7.5B	TK-408
Mfg. recommended minimum tube kit for FM-5C	TK-463	Mfg. recommended tube kit for FM-7.5B	TK-463
<b>FM-5C, 5-KW FM TRANSMITTER with tube rectifiers</b>	<b>M-6153</b>	<b>FM-7.5B, 7.5-KW FM TRANSMITTER with tube rectifiers</b>	<b>M-6097</b>
100% spare tubes for FM-5C	TK-461	100% spare tubes for FM-7.5B	TK-464
Mfg. recommended minimum tube kit for FM-5C	TK-462	Mfg. recommended minimum tube kit for FM-7.5B	TK-465

# 1000 WATT FM BROADCAST TRANSMITTER

## Model FM-1C

Gates offers a sparkling new 1000 watt FM transmitter for unexcelled stereo or monaural performance.

**CASCADE EXCITER — STEREO — MONAURAL —**  
— The "cascade" exciter utilizes two modulators operating in series for improved low frequency response. A sawtooth generator is driven by a crystal controlled oscillator. The sawtooth signal is modulated by the first modulator. This modulated signal is re-formed into another sawtooth wave-shape and is modulated again by modulator number two. This results in superior audio frequency response and lower distortion to develop the richness in quality so important at low frequencies. The "cascade" exciter is ideal for stereo or multiplexing as well as monaural broadcasting.

**PERFORMANCE —** The noteworthy operating characteristics of the new Gates FM-1C transmitter include 1% distortion or lower in the critical 30-15,000 cycle area and 1/2% distortion or lower between 100 and 10,000 cycles. The broad frequency response of 30-15,000 cycles, combined with low distortion, assures superb stereo and unsurpassed monaural performance. As supplied, the transmitter will tune from 88 to 108 megacycles without changes of components other than crystal. Each transmitter is factory tuned to the customer's frequency before shipment.

**CONSTRUCTION—FM-1C** is completely self-contained in one modern transmitter cubicle, 78" high, 26" wide and 35 1/2" deep, with a full size swinging front door and lift-off rear door. The front door may be opened without disengaging interlocks as it is dead front. Low noise cooling is developed by special impeller design of the blower. Single phase, input power may be accommodated from 208 to 230 volts. A VSWR output meter clearly indicates power output in watts and standing wave ratio. Metering is complete. Wiring for remote control is built-in and terminated.

**ELECTRICAL DESIGN—**From exciter output to transmitter output only two radio frequency stages are employed. This notable reduction in frequency multiplication greatly aids in elimination of spurious frequencies and further extends tube life as driver or power tubes acting as frequency multipliers assume greater power input and shorten tube life. The *Vane Tuned* power tank circuit utilizes 4-400A tubes in push-pull. The LC ratio of the tank circuit is designed so that no vacuum, air or mica capacitors are required thereby greatly increasing circuit reliability. A tuning vane varies the electrical length of the line and provides a positive and simple tuning adjustment which is essentially trouble free. The FM-1C incorporates automatic recycling



in case of momentary overload such as lightning burst or dip in power line.

**SOLID STATE RECTIFIERS—**Both the main high voltage and intermediate screen/IPA plate supplies utilize silicon diodes throughout. Generous safety factors as related to both voltage and current assure dependable, uninterrupted performance and resistance to aging by reason of moisture and wide temperature variances.

# MODEL FM-1C 1000 WATT FM BROADCAST TRANSMITTER

## SPECIFICATIONS

### POWER OUTPUT:

1000 Watts, Capable 1100 Watts.

### FREQUENCY RANGE:

88 to 108 MC.

### RF OUTPUT IMPEDANCE:

50 ohms.

### FREQUENCY STABILITY:

±.001%.

### TYPE OF MODULATION:

Phase shift employing pulse techniques and using the new exclusive Gates "cascade" circuit.

### MODULATION CAPABILITY:

±100 KC.

### AUDIO INPUT IMPEDANCE:

600 ohms.

### AUDIO INPUT LEVEL:

+10 dbm ±2 db.

### FREQUENCY RESPONSE:

30-15,000 cycles within +1 and -2 db.

### DISTORTION:

1% or less 30 to 15,000 cycles.

1/2% or less 100 to 10,000 cycles.

### NOISE:

65 db below 100% modulation (FM).

50 db below equivalent 100% (AM) modulation.

### POWER INPUT:

230/208 volts, 50/60 cycles, single phase three wire, 5 KVA demand. 115 volts, 50/60 cycles single phase, 500 watts.

### TUBES:

Exciter	1 — 6AQ5
7 — 6AU6	1 — 6080
3 — 6J6	1 — GZ34/5AR4
3 — 6201	
3 — 7025	IPA
2 — OA2	2 — 6146
1 — 12AX7	PA
1 — 6360	2 — 4-400A

### POWER SUPPLIES:

Silicon rectifiers.

### MAX. ALTITUDE:

7,500 feet.

### MAX. AMBIENT:

-20° to 45° C.

### MAX. VSWR OF LOAD:

1.7 to 1 maximum.

### SIZE:

Width—26", height—78", depth—36 1/2". Front door swing—21", Back door lift-off type.

### WEIGHT AND CUBAGE:

Packed—1140 lbs. Net—880 lbs. 70 cu. ft. packed.

### FINISH:

Two - tone gray with black accent. Brushed aluminum trim.

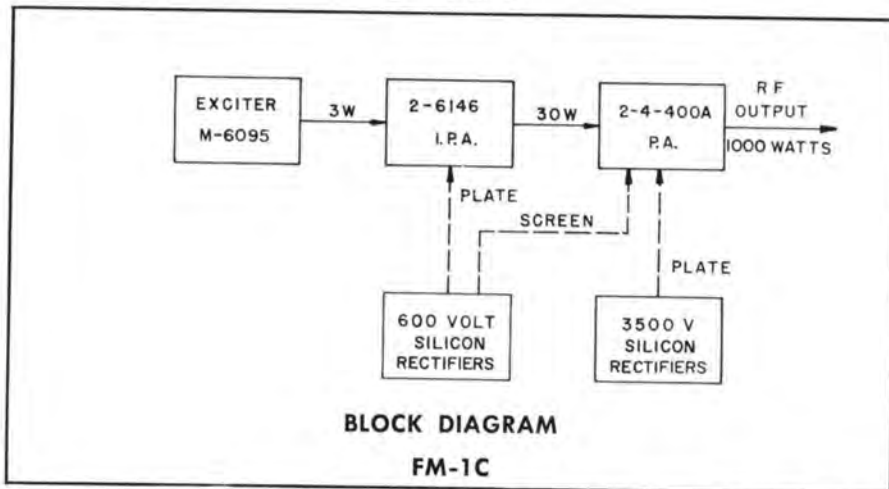
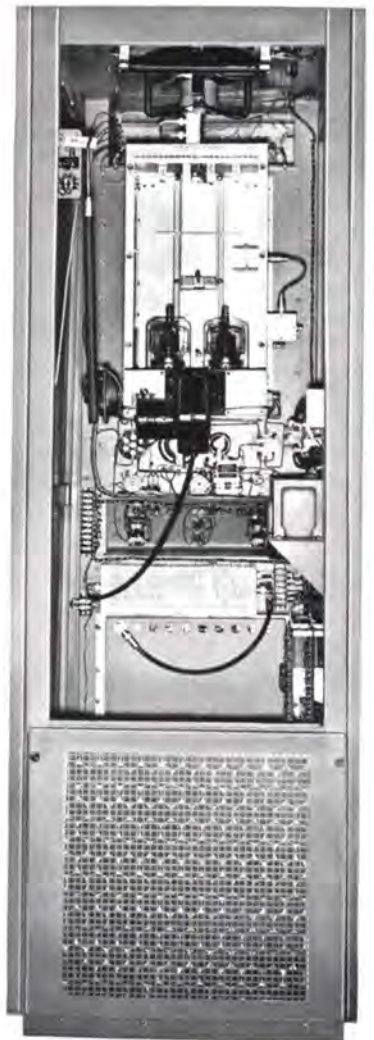

## ORDERING INFORMATION

FM-1C, 1-KW FM TRANSMITTER with silicon rectifiers

100% spare tubes for FM-1C

Mfg. recommended minimum tube kit for FM-1C

TK-312

TK-460



# 250 WATT FM BROADCAST TRANSMITTER

## Model FM-250C



The more rigid requirements for stereo and multiplexing were seriously considered in the decisive action by Gates engineers to offer the industry an entirely new transmitter instead of a modification of an earlier model. Wider response, lower distortion, greatly improved channel separation for stereo, and low noise, combine to provide the richest quality sound in FM broadcasting.

**CASCADE EXCITER**—The FM-250C transmitter utilizes Gates "cascade" exciter. The "cascade" exciter uses two modulators operating in series for improved low frequency response. A sawtooth generator is driven by a crystal controlled oscillator and its signal is modulated by the first modulator. This modulated signal is re-formed into another sawtooth waveshape and modulated again by modulator number two. The result is improved low audio frequency response and lower distortion.

**PERFORMANCE:** Operating characteristics of the FM-250C transmitter include 1% distortion in the 30-15,000 cycle area and 1/2% distortion or lower between 100 and 10,000 cycles. The broad frequency response of 30-15,000 cycles, combined with low distortion, assures superb stereo or monaural performance. The transmitter will tune from 88 to 108 megacycles without changes of components other than crystal. Each transmitter is factory tuned and tested on the customer's frequency before shipment.

**CONSTRUCTION:** FM-250C is completely self-contained in one modern transmitter cubicle, 78" high, 26" wide and 36 1/2" deep, with full size swinging front door and lift off rear door. Wiring for remote control is built-in and terminated.

**ELECTRICAL DESIGN:** The power amplifier uses a single 4CX250B tetrode with a modified Pi plate circuit and a series tuned grid circuit. Only three controls are used: grid tuning, plate tuning and output loading. The 4CX250B is air cooled in a low-noise air system socket with built-in screen by-pass. Operation is simple,

stable, and within conservative ratings. Approximately 3 watts are required from the exciter to drive the single ended 4CX250B tetrode to a full 250 watts output. From exciter output to transmission line at 250 watts there is only one radio frequency stage. The reduction of frequency multiplication greatly aids in the elimination of spurious frequencies and further extends tube life, as power type tubes doubling or tripling frequency will consume greater input power resulting in short tube life.

The transmitter is designed to operate from a 120 volt 60 cycle power supply. Metering is complete and includes a VSWR output meter for both power output and standing wave ratio indications. Seldom standard in transmitters of 250 watts power, the Gates FM-250C incorporates automatic recycling.

**SOLID STATE RECTIFIERS:** The main high voltage plate supply utilizes silicon diodes. Generous safety factors as related to both voltage and current assures dependable, uninterrupted performance and resistance to aging by reason of moisture and wide temperature variances.

# MODEL FM-250C 250 WATT FM BROADCAST TRANSMITTER

## SPECIFICATIONS

### POWER OUTPUT:

250 Watts.

### FREQUENCY RANGE:

88 to 108 MC.

### RF OUTPUT IMPEDANCE:

50 ohms.

### FREQUENCY STABILITY:

$\pm .001\%$ .

### TYPE OF MODULATION:

Phase shift employing pulse techniques and using the new exclusive Gates "cascade" circuit.

### MODULATION CAPABILITY:

$\pm 100$  Kc.

### AUDIO INPUT IMPEDANCE:

600 ohms.

### AUDIO INPUT LEVEL:

+10 dbm  $\pm 2$  db.

### FREQUENCY RESPONSE:

30-15,000 cycles within +1 and -2 db.

### DISTORTION:

1% or less 30-15,000 cycles.

$\frac{1}{2}\%$  or less 100 to 10,000 cycles.

### NOISE:

65 db below 100% modulation (FM).

50 db below equivalent 100% modulation (AM).

### POWER INPUT:

230 or 115 volts 60 cycles. (Specify).

950 watts (approx.).

### TUBES:

6 — 6AU6	1 — GZ34/5AR4
3 — 6J6	1 — 6360
3 — 6201	1 — 6AQ5
3 — 7025	1 — 6080
2 — OA2	1 — 4CX250B
1 — 12AX7	

### POWER SUPPLIES:

Silicon rectifiers.

### MAX. ALTITUDE:

7,500 feet.

### MAX. AMBIENT:

-20° to 45°C.

### MAX. VSWR OF LOAD:

1.7 to 1 Max.

### SIZE:

26" wide, 78" high, 36 $\frac{1}{2}$ " deep.

### FRONT DOOR SWING:

21 inches.

### BACK DOOR:

Lift-off type.

### WEIGHT:

Packed, 1140 lbs. Net, 510 lbs.

### CUBAGE:

70 cu. ft. packed.

### FINISH:

Two-tone gray with black accent.  
Brushed aluminum trim.

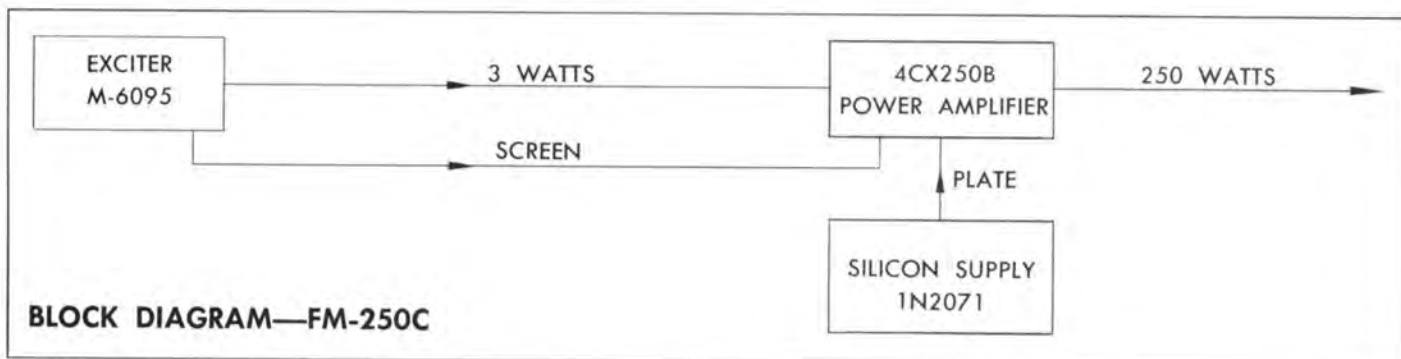
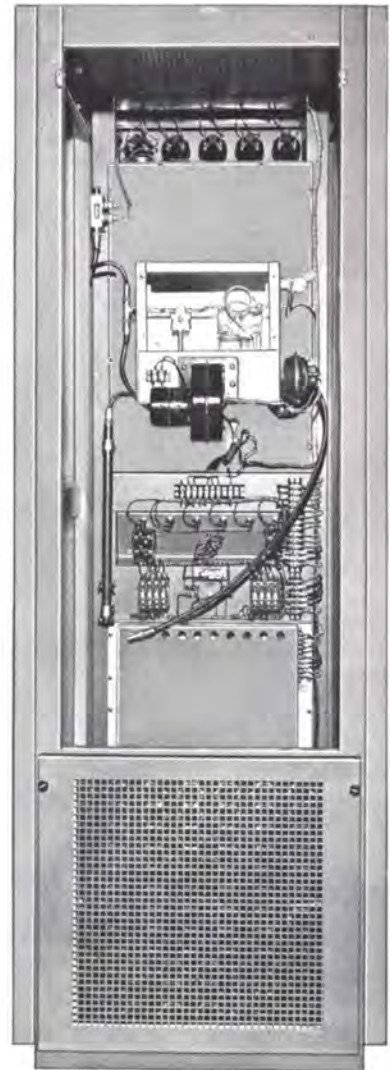

## ORDERING INFORMATION

FM-250C, 250 WATT FM TRANSMITTER with silicon rectifiers

100% spare tubes for FM-250C

Mfg. recommended minimum tube kit for FM-250C

M-6173

TK-411

TK-459



# 10 WATT AND 50 WATT FM TRANSMITTERS

## MODELS BFE-10C AND BFE-50C (BFR-50C SPECIAL ORDER) (Multiplexing Optional)



**Model BFE-10C:** FCC approved for educational FM broadcasting but used in all applications where 10 watts output is sufficient. Single or dual channel multiplexing optional either now or when required.

**Model BFE-50C:** Similar to the BFE-10C FM transmitter but with a 50 watt amplifier added to provide 50 watts output. Single or dual channel multiplexing is optional.

**Model BFR-50C:** Available on special order for 40-220 Mc operation.

New and modern in both electrical and mechanical design, these transmitters provide unusually low distortion and wide frequency response. Along with other metering, an audio level meter indicates modulation level. This feature makes the transmitter 100% complete without external accessories other than antenna and audio equipment. Heart of this equipment is the new M-6095 "cascade" exciter, utilizing a phase shift oscillator with pulse techniques. The "cascade" exciter is particularly adaptable to multiplexing and today's FM stereo.

Construction of the BFE-10C and 50C is functional as well as attractive. The full length, perforated front grill removes quickly by loosening two thumb nuts to expose tubes, adjustments and crystal oven. There is a full length slip-off rear door. The depth of only 14" is a space saver for either desk or wall mounting.

Multiplexing, either single or dual sub-channels, is available. In the BFE-50C fifty watt model, the 50 watt P.P. 6146 amplifier and its separate power supply, mount directly above the exciter.

### SPECIFICATIONS

**POWER OUTPUT:**  
BFE-10C 10 watts. BFR-50C, 50 watts.  
BFE-50C, 50 watts.

**FREQUENCY RANGE:**  
88-108 Mc, as ordered. On special order Model BFR-50C with frequencies up to 220 Mc.

**RF OUTPUT:**  
50 ohms (Type N. connector).

**OSCILLATOR:**  
Direct crystal controlled.

**STABILITY:**  
0.001% or better.

**MODULATION:**  
Phase shift, employing pulse techniques.

**FREQUENCY SWING:**  
±100 Kc: (±75 Kc=100% modulation in FM broadcasting). Model BFR-50C. Models below 80 Mc have maximum swing of ±40 Kc or less, as desired. Above 80 Mc may be ±75 Kc or less, as desired.

**INPUT:**  
+10 dbm ±2 db at 600 ohms impedance.

**RESPONSE:**  
Within 1 db of standard 75 microsecond pre-emphasis curve or flat ±1 db, 50-15,000 cycles, as desired. (If preference, state when ordering.)

**METERING:**  
RF output, audio level, plate current, plate voltage.

**DISTORTION:**  
1% or less 30-15,000 cycles.  
½% or less 100-10,000 cycles.

**NOISE:**  
65 db below 100% modulation (FM).  
60 db below equivalent 100% AM modulation.

**POWER:**  
115 volts, 50/60 cycles. BFE-10C, 120 watts, BFE-50C, 230 watts.

**RF HARMONICS:**  
Suppression meets or exceeds all FCC requirements.

**TUBES:**  
BFE-10C—(6) 6AU6, (1) 12AX7, (3) 6J6, (2) OA2, and one each 6AO5, GZ34/5AR4, 6080, 6360, (3) 6201, (3) 7025.  
BFE-50C—Same as above, with (2) 6146 and (1) 5R4GYA tube added.  
BFR-50C—Same as BFE-50C with (1) 5894 tube, (1) 6AQ5 and (1) 5R4SYA tube added.

**FINISH:**  
Medium gloss gray and black.

**SIZE:**  
26½" high, 28" wide, 14" deep.

**WEIGHT:**  
BFE-10C—Packed 116 lbs. Cubage 8.5.  
BFE-50C—Packed 165 lbs. Cubage 8.5.  
BFR-50C—Packed 165 lbs. Cubage 8.5.

### ORDERING INFORMATION

BFE-10C, 10 WATT FM TRANSMITTER	M-5594
100% spare tubes for BFE-10C	TK-319
Mfg. recommended minimum tube kit for BFE-10C	TK-488
BFE-50C, 50 WATT FM TRANSMITTER	M-5595
100% spare tubes for BFE-50C	TK-489
Mfg. recommended minimum tube kit for BFE-50C	TK-490

**ON SPECIAL ORDER:**  
BFR-50C, 50 WATT RELAY TRANSMITTER for 40-220 Mc operation with tubes, crystal and oven\* M-5599  
100% spare tubes for BFR-50C TK-310  
Mfg. recommended minimum tube kit for BFR-50C TK-458

\*State carrier frequency and frequency swing desired, when ordering.

# FM STEREO AND MULTIPLEXING

## FM STEREO GENERATOR MODEL M-6146

To meet the exacting demands of FM stereophonic broadcasting, Gates engineers have designed and developed the M-6146 Stereo Generator, a completely new FM stereo generating system. The basic equipment, which meets or exceeds all FCC requirements for FM stereo broadcasting includes the stereo generator and space for two optional M-6160 subcarrier generators. Featuring built-in matrix and a regulated silicon power supply, the generator has been designed along vertical construction lines for easy accessibility and maintenance.

Gates M-6146 stereo generator has been designed for both stereophonic and monophonic broadcasting with provision made for the addition of multiplex at any time. Stereo and 67 Kc can be used simultaneously, or if the customer chooses, he may switch stereo off and use 41 Kc and 67 Kc. The unit may be installed in any model FM transmitter.

This stereo generating equipment reflects Gates determination to provide FM stereo without compromising the broadcasters' SCA multiplex performance requirements. Gates stereo design objective, in addition to delivering superb stereo performance, is also to provide space for two-channel SCA in the same unit. This is a Gates exclusive and permits FM stereo and 67 Kc SCA simultaneously.

Gates stereo generating equipment is FCC type approved.

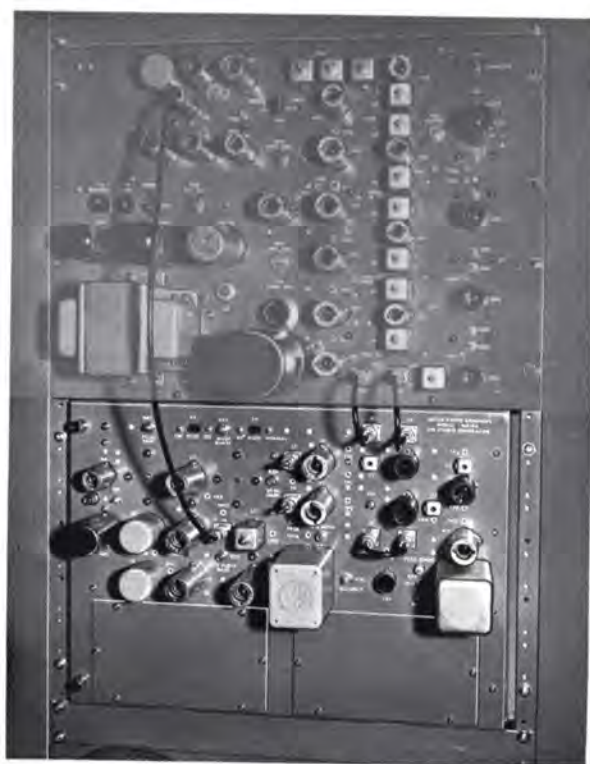

Top Unit — Gates "Cascade" FM Exciter.  
Lower Unit — M-6146 Stereo Generator.

## SPECIFICATIONS M-6146

**AUDIO INPUT IMPEDANCE (left and right):**  
600 ohms.

**AUDIO INPUT LEVEL (left and right):**  
+5 dbm each channel.

**DISTORTION:**  
Less than 1.0% 30 to 15,000 cps.

**FREQUENCY RESPONSE (left or right):**  
±5.0 db, 30-15,000 cps.

**FREQUENCY STABILITY (19Kc Pilot):**  
±1 cps.

**PILOT OSCILLATOR:**  
Crystal controlled in 60°C. Oven.

**NOISE:**  
-60 db.

**PERCENT MODULATION OF MAIN CARRIER BY PILOT:**  
8 to 10%.

**CROSSTALK (Sub-channel to Main channel):**  
40 db.

**CROSSTALK (Main channel to Sub-channel):**  
40 db.

**SUBCARRIER SUPPRESSION (38 Kc):**  
40 db.

**SCA PROVISIONS:**  
Space provided for 41 Kc and 67 Kc Sub-channel Generators.

**POWER INPUT:**  
117V single phase, 50 watts.

TUBES:	Type	Quantity
	6201 (12AT7)	2
	7025 (12AX7)	5
	6BY6	2
	6AK5	1
	6AK6	1

**SIZE:**  
Width 19 inches. Height 12½ inches. Depth 8 inches.

## SUB-CARRIER GENERATOR WITH MUTE MODEL M-6160

### SPECIFICATIONS

**FREQUENCIES:**  
Any sub-carrier frequency between 25 Kc and 75 Kc.

**FREQUENCY STABILITY:**  
1.0% or less.

**AUDIO INPUT:**  
600 ohms at approx. +10 dbm.

**FREQUENCY RESPONSE:**  
±2 db, 50-7500 cycles.

**DISTORTION:**  
3% or less at 100% modulation.



M-6160 Sub-Carrier Generator with Mute

## ORDERING INFORMATION

FM Stereo Generator ..... M-6146  
Sub-Carrier Generator with Mute ..... M-6160





# CYCLOID

## FM Ring Antenna

The *Cycloid*\* FM antenna completes Gates' FM system to provide a highly efficient antenna for FM stereo and all FM broadcasting needs. The field proven *Cycloid* offers new innovations and improvements available exclusively from Gates.

**BINARY ADJUSTMENT:** *Binary Adjustment* is the first major technological advance in antenna design since the initial development of ring type radiating elements. With this patented\*\* product exclusive, the Gates FM antenna is adjusted for capacitive tuning while the same adjustment changes the inductance of the ring. The advantage is that one ring can be adjusted to cover a major portion of the FM spectrum.

The nature of *Binary Adjustment* permits the antenna to be tuned to a low standing wave ratio over a wide range of frequencies. Fine tuning of the inductance is achieved by moving the feed strap up or down the middle semicircular element. Since all of the adjustment is incorporated in the antenna, it is not necessary to buy costly extras such as transformers or field tuning kits to achieve the optimum low standing wave ratio.

The Gates *Cycloid* FM antenna is pretuned at the factory to the customer's frequency assuring the most efficient installation.

**VOLTAGE STANDING WAVE RATIO:** A voltage standing wave ratio of 1.1 to 1 is attainable with the Gates *Cycloid* antenna by field tuning the array. If the antenna is mounted on a supporting pole and pretuned at the factory, a voltage standing wave ratio of 1.2 to 1 or better,



at the one megacycle bandwidth points should be expected. A side mounted antenna, pretuned at the factory should provide a voltage standing wave ratio of 1.5 to 1 or better, at one megacycle bandwidth points. The bandwidth of the Gates *Cycloid* antenna is ideal for stereo and multiplexing (see Figure 3) and is sufficient to minimize the detuning effect sometimes caused by atmospheric conditions.

**GAIN:** Gain of the Gates *Cycloid* FM antenna is in direct relation to the number of bays in the antenna array. This measurement is possible due to rigid quality controls that assure identical electrical and mechanical characteristics of the antenna rings. Gates *Cycloid* antenna is available for one to sixteen element arrays to cover any FM antenna application. By referring to Figure 1 you can estimate the antenna gain in relation to the antenna length and number of bays.

**CIRCULARITY:** A horizontal radiation pattern is influenced by many factors, including the location of transmission lines, guy wires and other conducting elements in the area of the antenna, the nature of the supporting structure, and other antennas in the area. These factors are all variables, however, and can be controlled by requesting factory recommendations for proper installation procedures.

The most important determining factor for a good horizontal pattern is the circularity of the antenna element in free space. The Gates *Cycloid* FM antenna is circular within  $\pm 1$  db in free space to provide the best possible starting point for an optimum horizontal pattern.

**HEATERS:** Gates offers a choice of two heating elements with the Cycloid antenna. For extreme icing, the FMH-400 heater is recommended. It provides 400 watt elements, operating on 115 volts to handle the most rugged and demanding icing conditions. Where limited icing is encountered, but heaters are still desirable, the FMH-200 with 200 watt elements, operating on 115 volts, is available. The cartridge type heater elements are flexible and extend the full circumference of the ring. They can be replaced in the field if necessary.

FIGURE 1

ANTENNA BAYS	ANTENNA LENGTH	ANTENNA GAIN
2	10	2
3	20	3
4	30	4.1
5	40	5.2
6	50	6.3
7	60	7.3
8	70	8.4
9	80	9.4
10	90	10.5
11	100	11.5
12	110	12.5
13	120	13.6
14	130	14.6
15	140	15.6
16	150	16.6

ANTENNA LENGTH and POWER GAIN for GATES CYCLOID ANTENNA

\*Trade name.

\*\*Patent applied for.

## CYCLOID FM RING ANTENNA

**MOUNTING:** Mounting brackets are tailored to each installation and are furnished for pole or side mounting. The mechanical simplicity of the feed system allows for easy installation, side mounted on an existing tower, or top mounted with a special mounting pole. In addition, the antenna may be mounted inside the tower, thus offering the widest choice of installation possibilities. A single, interconnecting feed line consisting of standard EIA rigid 1 5/8" or 3 1/8" coaxial line is used to feed the antenna. The rings are supported by this sturdy Teflon insulated line.

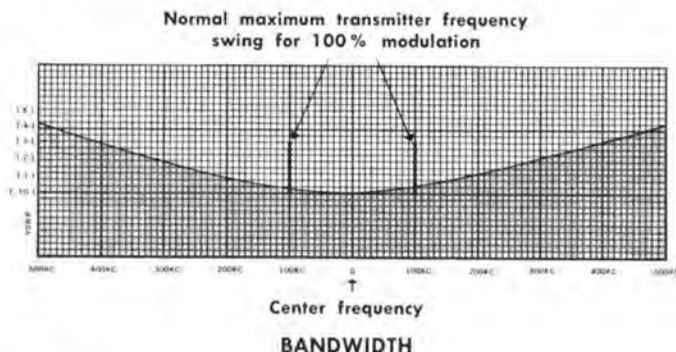

### SPECIFICATIONS

**FREQUENCY RANGE:**

Factory tuned on customer's frequency in 88-108 Mc band.

**POLARIZATION:**

Horizontal. (Vertical polarization on special order.)

**HORIZONTAL PATTERN:**

Circular  $\pm 1.0$  db in free space.

**INPUT IMPEDANCE:**

50 ohms, on 1 5/8" or 3 1/8" coax.

**VSWR (without field tuning):**

Top Mounting — 1.2 to 1.  
Side Mounting — 1.5 to 1.

**VSWR (with field tuning):**

Top Mounting — 1.1 to 1.  
Side Mounting — 1.1 to 1.

**WINDLOAD:**

20 lbs. per square foot.

**DIMENSIONS (1 bay):**

Height (over-all) — 6".  
Ring Diameter—approx. 18" (depends on frequency).

**WEIGHT:**

25 lbs. per ring.

**EQUIPMENT FURNISHED:**

Antenna mounting hardware—(specify type of tower and name of original manufacturer).  
Antenna elements as required.  
Interconnecting rigid coax 1 5/8" or 3 1/8", EIA 1 5/8" or 3 1/8" flanges.

**ACCESSORY EQUIPMENT:**

De-icers:  
200 watt — FMH-200.  
400 watt — FMH-400.  
Power cable for heaters.

### Horizontal Polarization Chart (side or top mounting)

TYPE NUMBER (See Note 4 below)	FMA-1	FMA-2	FMA-3	FMA-4	FMA-5	FMA-6	FMA-7	FMA-8	FMA-10	FMA-12	FMA-14	FMA-16
NO. OF BAYS	1	2	3	4	5	6	7	8	10	12	14	16
Field Gain	.95	1.41	1.73	2.02	2.28	2.51	2.70	2.90	3.25	3.55	3.83	4.07
Power Gain	.9	2	3	4.1	5.2	6.3	7.3	8.4	10.5	12.5	14.6	16.6
Length in feet	6 in.	10 ft.	20 ft.	30 ft.	40 ft.	50 ft.	60 ft.	70 ft.	90 ft.	110 ft.	130 ft.	150 ft.
Weight in lbs.	25	50	95	120	150	180	210	240	300	360	420	480

- It is not advisable to use more than a 10 KW transmitter on 1 5/8" line or 20 KW on a 3 1/8" line.
- Windloads are based on 20 pounds per sq. ft. on projected areas of cylindrical surfaces with all sections considered round.

- Power gains compared to 1/2 wave dipole.
- Type number will be followed by an "A" or "B" indicating coax size:  
Example—FMA-4A.  
A = 1 5/8" coax      B = 3 1/8" coax

### ORDERING INFORMATION

The CYCLOID antenna is available with any number of bays from 1 to 16 and with 1 5/8" or 3 1/8" line.

If heaters are required, 200 watt and 400 watt are available.



# 5000 WATT VHF TELEVISION TRANSMITTER

## Model BT-5C

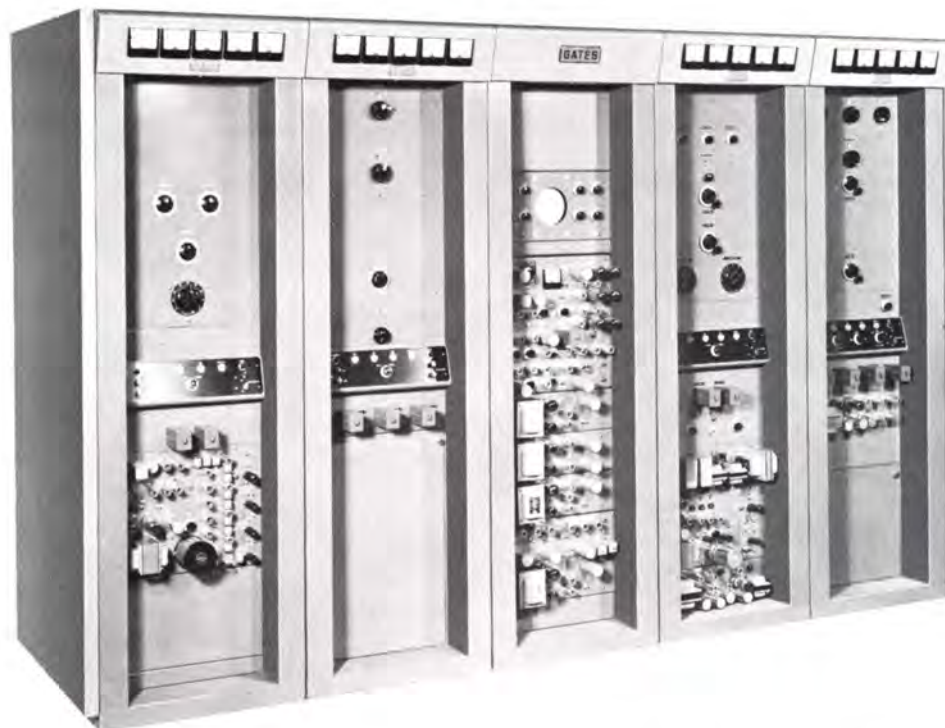

The Gates BT-5C five kilowatt VHF TV transmitter is designed for exacting color and monochrome television transmission. Completely self-contained (vestigial sideband filter mounted externally), including blowers and power components, the BT-5C requires total floor space of only 10 feet by 3 feet. The two aural cabinets and the three visual cabinets are mounted together as one complete transmitter—the aural being the two left hand cubicles and the visual, the remaining three. It is possible to supply separate side panels for both sections so the transmitters may be mounted in operating positions separate from one another.

Separate high voltage power supplies are provided for both the aural and visual transmitter. The BT-5C also includes a new and improved video modulator with keyed clamping and automatic switch over to AC coupling with reduced carrier power in case of sync or program failure. The visual transmitter is grid modulated in the 500 watt visual driver by a dynamic cathode load modulator circuit. Video modulator of the new transmitter is equipped with RF bias failure alarm lamp, test meter, and an abundance of front panel test jacks. The BT-5C uses 6076 tetrodes in final amplifier of both visual and aural transmitters.

Among the latest technical advancements incorporated in the video modulator is sync-tip keyed clamping. Used to avoid disturbing color signal components, sync-tip clamping means no "back-porch" disturbances of the color synchronizing burst. Built-in and operating from the composite signal input, the keyed clamp generator uses a delay-line controlling keying pulse for maximum stability. Fail-safe protection circuits are provided which reduce power to mid-gray level in event of clamp or signal failure.

A white peak clipper is provided to considerably reduce the possibility of sync-buzz due to accidental over modulation of white portion of picture that extends beyond the 10% point of carrier transmission. A white stretcher circuit improves differential gain and a sync stretcher provides adjustment of transmitted sync percentage to conform with FCC requirements. Inbuilt feedback restoration is provided to remove hum and/or tilt, thus minimizing the need for a stabilizing amplifier. Visual input coaxial cable terminations are adjustable and time proven tubes are used in modulator and power supply.

World-wide users include DZBB Manila, P.E.; CKRT, Rivere-du-Loup, Canada; KREX, Grand Junction, Colorado; Telesistema Mexicano, Mexico and many others.

# BT-5C 5000 WATT VHF TELEVISION TRANSMITTER

## SPECIFICATIONS

### POWER INPUT:

230 volts, 50/60 cycles, three phase. Power consumption, 28-KVA.

### POWER OUTPUT:

Channels 2 thru 6: Visual 5000 watts.

Aural 2500 watts.

Channels 7 thru 13: Visual 4000 watts.

Aural 2000 watts.

(Generous excess to rated power is available for sideband filter and system losses.)

### RF OUTPUT IMPEDANCE:

50.0 ohms, 1/8 RETMA Flange.

### INPUT IMPEDANCE:

Video signal—75 ohms, unbalanced, Audio signal—600 ohms, balanced.

### FREQUENCY RESPONSE:

Visual +2 to -2 db at 0.5 mcs.

Visual +2 to -2 db at 1.25 mcs.

Visual +2 to -2 db at 2.0 mcs.

Visual +2 to -2 db at 3.58 mcs.

The amplitude response will not vary more than +1 db to -2 db from the 3.58 mcs. response between 2.1 mcs. and 4.18 mcs. The amplitude at 4.75 mcs. is attenuated 20 db and frequencies higher than 4.75 mcs. are attenuated 20 db or greater.

Lower sideband response is:

Visual -20 db at 1.25 mcs., and

-42 db at 3.58 mcs.

Aural within 1.0 db of standard 75 microsecond preemphasis curve, 50 - 15,000 cycles.

### FREQUENCY STABILITY:

Visual  $\pm 500$  cycles.

Aural  $\pm 500$  cycles.

### MODULATION CAPABILITIES:

Visual to 12 1/2%  $\pm 2 1/2%$  of sync level. Aural  $\pm 40$  Kc.

### INPUT LEVEL:

Visual 1.0 V.  $\pm 0.4$  V. peak to peak. Aural +10 dbm  $\pm 2$  db for 100% modulation.

### NOISE:

Aural 60 db below 100% modulation (FM).

50 db below equivalent 100% modulation (AM).

Visual 40 db below 100% AM modulation.

### AUDIO FREQUENCY DISTORTION:

50-100 cycles, 1.5% max.

100-10,000 cycles, 1% max.

10,000-15,000 cycles, 1.5% max. (at 25 Kc Swing).

### AMPLITUDE VARIATION:

5% or less of peak sync. (one field)

### SUBCARRIER PHASE vs BRIGHTNESS:

$\pm 7^\circ$  maximum.

### LINEARITY:

$\pm 15%$  maximum.

### ENVELOPE DELAY TOLERANCE:

(From FCC Specified Curve).

$\pm 0.08$  microseconds from 0.2-2.1 mc.

$\pm 0.04$  microseconds at 3.58 mcs.

$\pm 0.08$  microseconds at 4.18 mcs.

### HARMONIC ATTENUATION:

60 db or better.

### REGULATION OF OUTPUT:

7% from black to all white.

### INPUT POLARITY:

Black negative.

### TYPE OF MODULATION:

Phase shift employing pulse techniques (Aural)

### TYPE OF OSCILLATOR:

Direct crystal controlled (both aural and visual).

### TUBES:

Visual: (3) 6AU6, (1) 6AK6, (6) GZ34/5AR4, (5) 6080, (11) OA2, (9) 12AT7, (2) 6CL6, (7) 6CA7, (3) 5651, (5) OB2, (3) 6AU8, (5) 12AX7, (1) 6X4, (1) 5894, (2) 4X250B, (2) 6076, (4) 866, (6) 8008, (1) 5R4.

Aural: (1) 12AT7, (7) 6AU6, (3) 12AX7, (3) 6J6, (2) OA2, (1) 6360, (1) 6AQ5, (1) 6080, (1) GZ34/5AR4, (1) 4X250B, (1) 6076, (2) 866, (6) 8008, (1) 6360, (3) 12BH7, (1) 6CS6.

### TOTAL NUMBER OF TUBES:

Visual 82. Aural 30.

### TOTAL TUBE TYPES:

24.

### SIZE (OVER-ALL):

Width 96" (less end bells), 99" (with end bells).

Height 78".

Depth 36 1/2".

### WEIGHT:

Packed 3000 lbs. Net 2500 lbs.

### CUBAGE:

136 cu. ft. unpacked.

### SIDEBAND FILTER:

Mounted external to cabinet.

### COOLING:

Forced air.

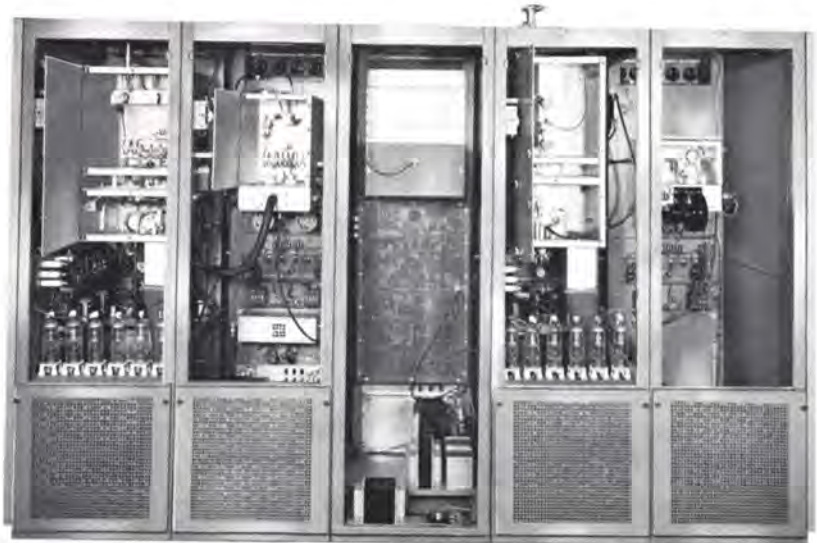

## ORDERING INFORMATION

BT-5CL Transmitter for channels 2 - 6

BT-5CH Transmitter for channels 7 - 13

Spare 100% tube complement for BT-5CL

Spare 100% tube complement for BT-5CH

Color video filter (with power supply)

M-6066

M-6077

TK-341

TK-343

M-5892



# 500 WATT VHF TELEVISION TRANSMITTER

## Model BT-500C

The Gates BT-500C is used throughout the world in leading television stations. Designed to meet FCC color specifications in the channel 2 to 13 band, it is an outstanding expression of the latest achievement in television transmission. The video modulator has sync-tip keyed clamping, sync stretcher, white peak clipper and a white stretcher circuit to improve differential gain. The most exacting color and monochrome transmission is possible.

The BT-500C is completely self-contained in three cubicles—the left cubicle is the aural section and the remaining two the visual. There are separate high voltage power supplies for the aural and visual sections. Type 4x250B tetrodes are employed in the final amplifiers of the aural and visual sections. The video modulator is equipped with bias-failure alarm lamp, test meters and numerous front panel test jacks. Keyed clamping and automatic switch-over to AC coupling are used in the video modulator in case of program or sync failure. Visual transmitter is grid-bias modulated in the 500 watt visual amplifier by a dynamic cathode load modulator circuit. Rated power output is 500 watts peak visual.

The BT-500C can be enlarged to 5000 watts at anytime by adding a Gates 5KW visual and aural power amplifier. The 250 watt aural section uses a phase shift modulator employing pulse-timing techniques. The 10 watt Exciter drives a single power amplifier stage. The two power supplies in the aural section are: (1) low voltage and (2) 2000 volt high voltage. With a conservatively rated tube complement and rigid construction, trouble-free performance may be expected. Lack of frequency multiplication after the exciter unit aids in eliminating spurious frequencies and increases tube life. The 250 watt power amplifier is totally enclosed in a non-ferrous housing containing air-cooled tubes and components.

The visual portion of the BT-500C consists of oscillator, exciter, IPA, 500 watt modulated amplifier, PA control unit, regulated screen and bias supplies for PA, modulator, modulator power supplies, monochrome equalizers and 4.75 video cutoff filter. Sync-tip keyed clamping is used to avoid disturbances of the color signal components and the color synchronizing burst. The keyed clamp generator uses a delay-line controlled keying pulse. Fail-safe protection circuits are provided to reduce power to midgray level in case of clamp or signal failure. A white peak clipper reduces the possibility of sync-buzz. A white stretcher circuit improves differential gain. In-built feedback restoration is used to remove hum and/or tilt. The visual oscillator is designed to control the visual carrier frequency of the trans-



Model BT-500CL Channels 2-6.  
Model BT-500CH Channels 7-13.

mitter of both low and high band channels. Output is multiplied 3 times for low band and 9 times for high band channels. Under normal operating conditions, the oscillator will hold carrier frequency to within 300 cycles. Since the aural carrier itself is held within 300 cycles, FCC requirements are exceeded in color and monochrome transmission. Exciter, oscillator and power supply are contained in one panel. Crystal is in a thermostatically controlled oven. Tuning adjustments are from the front and eleven meters indicate all necessary circuits directly or by multi-metering.

Latch-on type back doors are used. All incoming air is filtered through removable filters. Finish is two-tone gloss gray with chrome trim and black escutcheons.

## SPECIFICATIONS

### POWER INPUT:

230 volts, 50/60 cycles, single phase. (120 volts for crystal heaters.) Power consumption, 3.5 KVA.

### POWER OUTPUT:

Visual 500 watts peak. Aural 250 watts. (Excess to rated power is available for sideband filter and system losses.)

### RF OUTPUT IMPEDANCE:

50.0 ohms, type N female.

### INPUT IMPEDANCE:

Video—75 ohms, unbalanced.  
Audio—600 ohms, balanced.

# 500 WATT VHF TELEVISION TRANSMITTER

## SPECIFICATIONS—continued

### FREQUENCY RESPONSE:

- Visual: +2 to -2 db at 0.5 mcs.
- +2 to -2 db at 1.25 mcs.
- +2 to -2 db at 2.0 mcs.
- +2 to -2 db at 3.58 mcs.

(The amplitude response will not vary more than +1 db to -2 db from the 3.58 mcs. response between 2.1 mcs. and 4.18 mcs. The amplitude at 4.75 mcs. is attenuated 20 db and frequencies higher than 4.75 mcs. are attenuated 20 db or greater.)

### Lower sideband response is:

- Visual: -20 db at 1.25 mcs. and -42 db at 3.58 mcs.
- Aural: Within 1.0 db of standard 75 microsecond pre-emphasis curve, 50-15,000 cycles.

### FREQUENCY STABILITY:

- Visual  $\pm 500$  cycles.
- Aural  $\pm 500$  cycles.

### MODULATION CAPABILITIES:

Visual to  $12\frac{1}{2}\%$   $\pm 2\frac{1}{2}\%$  of sync level. Aural  $\pm 40$  Kc.

### INPUT LEVEL:

- Visual 1.0 V.  $\pm 0.4$  V. peak to peak.
- Aural +10 dbm  $\pm 2$  db for 100% modulation.

### NOISE:

Aural 60 db below 100% modulation (FM). 50 db below equivalent 100% modulation (AM). Visual approximately 45 db below 100% AM modulation.

### AUDIO FREQUENCY DISTORTION:

50-100 cycles, 1.5% max. 100-10,000 cycles, 1% max. 10,000-15,000 cycles, 1.5% max. (at 25 Kc swing).

### AMPLITUDE VARIATION:

5% or less of peak sync. (One field.)

### SUBCARRIER PHASE vs. BRIGHTNESS:

$\pm 7^\circ$  maximum.

### LINEARITY:

$\pm 15\%$  maximum.

### ENVELOPE DELAY TOLERANCE:

(From FCC Specified Curve.)

- $\pm 0.08$  microseconds from 0.2-2.1 mc.
- $\pm 0.04$  microseconds at 3.58 mcs.
- $\pm 0.08$  microseconds at 4.18 mcs.

### HARMONIC ATTENUATION:

60 db or better.

### REGULATION OF OUTPUT:

7% from black to all white.

### INPUT POLARITY:

Black negative.

### TYPE OF MODULATION:

Phase shift employing pulse techniques. (Aural).

### TYPE OF OSCILLATOR:

Direct crystal controlled (both aural and visual).

### TUBES:

#### Visual:

(3) 6AU6, (1) 6AK6, (4) 6080, (8) OA2, (9) 12AT7, (2) 6CL6, (7) 6CA7, (3) 5651, (4) OB2, (3) 6AU8, (1) 6CS6, (3) 12BH7, (4) 12AX7, (1) 6X4, (1) 5894, (2) 4X250B, (2) 866, (1) 5R4, (1) 6360L, (5) 5AR4.

#### Aural:

(1) 12AT7, (7) 6AU6, (3) 12AX7, (3) 6J6, (2) OA2, (1) 6360L, (1) 6AQ5, (1) 6080, (1) 4X250B, (2) 866, (1) 5AR4.

### TOTAL NUMBER TUBES:

Visual 65. Aural 23.

### SIZE (OVER-ALL):

Width 72" (less end bells), 75" (with end bells), height 78", depth 36 $\frac{1}{2}$ ".

### WEIGHT AND CUBAGE:

Packed 2000 lbs. Net 1500 lbs. 117 cu. ft. unpacked.

### SIDEBAND FILTER:

Mounted external to cabinet.

### COOLING:

Forced air.



## ORDERING INFORMATION

BT-500CL Broadcast Television Transmitter, 500 watts, with tubes, one crystal and oven for channels 2-6	M-6068
BT-500CH Broadcast Television Transmitter, 500 watts, with tubes, one crystal and oven for channels 7-13	M-6069
Spare 100% tube complement for BT-500CL	TK-357
Spare 100% tube complement for BT-500CH	TK-358
FCC minimum tube complement:	
For BT-500CL	TK-365
For BT-500CH	TK-366
Color video filter (with power supply)	M-5892

NOTE: The Gates BT-500C should be ordered with the optional M-5892 color video filter for color transmission. The filter replaces a blank panel space in the monochrome transmitter.



# 120 WATT VHF TV TRANSMITTER

## Model BT-100C



The Gates BT-100C is the most outstanding new television transmitter developed in the United States during the past five years. The transmitter was designed especially for the CCIR 625 line standards and for operation with 50 cycle power source. The BT-100C is field proven at overseas locations, including the tropics, operating on CCIR standards. When operated on U.S. 525 line standard on 60 cycle power the BT-100C is rated very conservatively at 120 watts peak visual power.

Housed in one cabinet, the BT-100C transmitter is a compact self-contained unit. All tuning controls are accessible from the front panel and lift off rear and side panels are provided for ease of maintenance. Air cooled, the transmitter incorporates a clever and efficient air distribution system which assures proper cooling of all components.

The vestigial sideband filter is installed inside the transmitter cabinet and is carefully tuned to the operating channel specified. A visual demodulator is included as standard equipment providing 1 volt peak to peak at 75 ohms monitoring output.

The video modulator uses the very latest design techniques which is the key to the sparkling high resolution picture transmitted by the BT-100C. A multimeter is provided on the modulator panel for ease of adjustment.

The control circuit of the BT-100C is designed so that remote control is easily accomplished which makes the transmitter very suitable for satellite unattended operation.



### SPECIFICATIONS

#### FREQUENCY RANGE:

(L) 54-88 Mc US-FCC Channels 2-6. (H) 174-216 Mc US-FCC Channels 7-13. Supplied adjusted to channel specified on order.

#### RF POWER OUTPUT:

120 watts peak Visual. 60 watts average Aural.

#### RF OUTPUT CONNECTOR:

Type "LC" female jack, Visual & Aural.

#### RF POWER OUTPUT IMPEDANCE:

50 ohms.

#### VIDEO INPUT CONNECTOR:

Type "UHF" female jack.

#### VIDEO INPUT IMPEDANCE:

75 ohms unbalanced,  $\pm 15$  ohms adjustable.

#### VIDEO INPUT LEVEL:

1.0 V. p-p  $\pm 0.5$  V.

#### VIDEO INPUT POLARITY:

Black negative.

#### AUDIO INPUT IMPEDANCE:

600 ohms, balanced.

#### AUDIO INPUT LEVEL:

+10 dbm, +0-4 dbm.

#### VISUAL VESTIGIAL SIDEBAND FILTER:

Included, built in.

#### VISUAL FREQUENCY RESPONSE (Below ideal demodulated

curve. 200 Kc reference.):

Upper sideband  $\pm 2$  db at 0.5 through 4.0 Mc, more than -20 db at 4.75 Mc or higher. Lower sideband +0, -4 db at 0.75 Mc, more than -20 db at 1.25 mc or higher.

#### AURAL FREQUENCY RESPONSE (Below ideal 75 micro-second

pre-emphasis curve.):

+0, -2 db at 30-15,000 CPS.

#### AURAL HARMONIC DISTORTION:

50-100 CPS, 1.0% or less. 100-10,000 CPS, 0.5% or less. 10-15 Kc, 1.0% or less.

#### TYPE OF OSCILLATOR:

Direct crystal control Visual and Aural.

#### CARRIER FREQUENCY STABILITY:

$\pm 500$  CPS Visual and Aural.

#### VISUAL CARRIER FREQUENCY ABOVE BAND EDGE:

1.25 Mc.

#### AURAL CARRIER FREQUENCY ABOVE VISUAL:

4.5 Mc  $\pm 1$  Mc.

#### AURAL FREQUENCY MODULATION:

Phase shift employing pulse techniques.

#### MODULATION, AURAL:

$\pm 25$  Kc. Capable  $\pm 40$  Kc.

#### MODULATION, VISUAL:

Amplitude, Capable 90%.

#### VISUAL OUTPUT AMPLITUDE:

Sync 100%. Blank 75  $\pm 2.5\%$ . White 12.5  $\pm 2.5\%$ .

#### REGULATION OF VISUAL OUTPUT:

(All white to all black picture.) 7% Maximum.

#### VISUAL AMPLITUDE VARIATION (Hum and Tilt over one frame):

5% maximum of peak sync.

#### SYSTEM CAPABLE OF OPERATING INDEPENDENTLY OF POWER

#### SUPPLY FREQUENCY:

Yes.

#### BLACK LEVEL INDEPENDENT OF PICTURE CONTENT:

Yes.

#### VISUAL MONITOR OUTPUT:

Visual RF demodulator and white reference chopper built in with 1.0 V. p-p output across 75 ohms.

#### NOISE:

Aural below 100% FM -60 db.

Aural below 100% AM -50 db.

Visual hum and noise -40 db.

#### AMBIENT TEMPERATURE:

+5°C. to +50°C.

#### ALTITUDE:

7500 ft. maximum. (Available for 10,000 ft.)

#### DIMENSIONS:

Height 78 inches. Depth 36 $\frac{1}{2}$  inches. Width 27 inches with end bells. Width 24 inches without endbells.

#### WEIGHT:

Net 800 lbs., Gross 1000 lbs. packed.

#### VOLUME:

84 cubic ft. packed.

### ORDERING INFORMATION

BT-100CL Transmitter for channels 2-6 ..... M-6179

BT-100CH Transmitter for channels 7-13 ..... M-6180

Spare 100% tube complement for BT-100CL ..... TK-491

Spare 100% tube complement for BT-100CH ..... TK-418

# CONRAC TELEVISION MONITORS



CMC 17/N



CMC 17/C

## CONRAC CMC TELEVISION MONITORS 14" - 17" - 21"

The Conrac CMC type video monitor incorporates many features normally found only in master monitors. It is especially designed for use in television broadcast control rooms, tape and film editing rooms and other locations where high resolution and excellent stability are required.

Video response is flat to beyond 10 megacycles, assuring resolution in excess of 800 lines. The final stage of the video amplifier employs two power tubes in parallel, providing high output with extremely low distortion. Differential gain is below 5% at 75 volts kinescope drive for excellent gray scale characteristics. The deflection circuits are capable of producing both horizontal and vertical linearity within 1% of picture height.

All operating controls, including electrical centering and electrical focus, are available on the front panel.

Of special interest is the picture size control which changes the display from normal full scan to reduced scan, completely showing all four sides and corners. This is accomplished without change in brightness, contrast or linearity.

Conrac-developed gating circuit eliminates the bending or "hooking" of vertical lines at the top of the picture regardless of setting of the horizontal hold control.

The kinescope employed is a newly developed electrostatic focus type. The spot size and shape are considerably improved over kinescopes in general use. Smaller spot size gives markedly improved resolution over the entire screen, and its superiority is particularly noticeable when viewing the corners. A 70° deflection system is used in all models of the CMC monitor.

A switch to select either composite video or separate video and composite sync inputs is provided. Both video and sync inputs are equipped with parallel receptacles for loop-through operation. The video input is provided with a terminating resistor switch.

A switch is provided to permit selection of either 100% or zero DC restoration.

The CMC monitor has been conservatively designed for continuous operation. Minimum service will be required to maintain the equipment in a satisfactory operating condition.

Television Monitors, 14" - 17" - 21" (Please Specify)

Chassis only	CMC/N
Rack Mounted	CMC/R
Cabinet Model	CMC/C



CNA8/2R



CNA8/C

## CONRAC CNA8 TELEVISION MONITOR 8" ONLY

The Conrac CNA8 monitor is a full scale broadcast quality video presentation device in a very small package. It is designed for broadcast and industrial television applications. The CNA8 presents a clear bright picture in continuous duty operation. A minimum amount of service is required to maintain the unit in top operating condition.

Video response is flat to 8 megacycles assuring resolution in excess of 600 lines. Differential gain is below 5% at 50 volts kinescope drive for excellent gray scale characteristics. The deflection circuits produce both horizontal and vertical linearity within 2% of picture height.

In a portable case, with carrying handle, the CNA8/C measures 9 1/4" wide x 11 1/8" high x 18" deep. The compact chassis size permits mounting two monitors side by side in a standard 19" relay rack, and this assembly, Model CNA8/2R, requires only 10 1/2" of vertical rack space for two independent picture presentations.

8" Television Monitor, in portable case	CNA8/C
Chassis only	CNA8/N
Rack Assembly	CNA8/2R



## CONRAC CLB TELEVISION MONITOR 14" RACK MOUNT

The Conrac CLB is a general purpose video monitor. It is designed for broadcast and industrial television applications. Video response is flat to 10 megacycles assuring resolution of 800 lines.

Size is 19" wide, 10 1/2" high, 17 1/2" deep. Net Wt. 57 lbs.

14" Monitor, Rack Mount Only Model CLB

## VIDEO PATCH PANEL

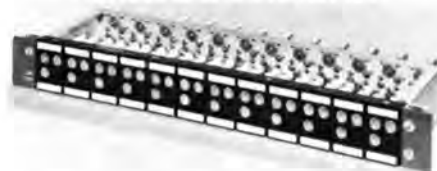

For patching coaxial circuits. 12 groups of 3 jacks on a strip 2 1/8" x 19". Contacts heat treated beryllium copper. Outer braid of coaxial cable may be soldered directly to jacks for complete shielding. Patch cords and plugs listed and illustrated below.



Video patch panel 963	
Looping plug	965
18" patch cord	967A
24" patch cord	967B
965	967





# 50,000 WATT AND 100,000 WATT HF BROADCAST TRANSMITTERS

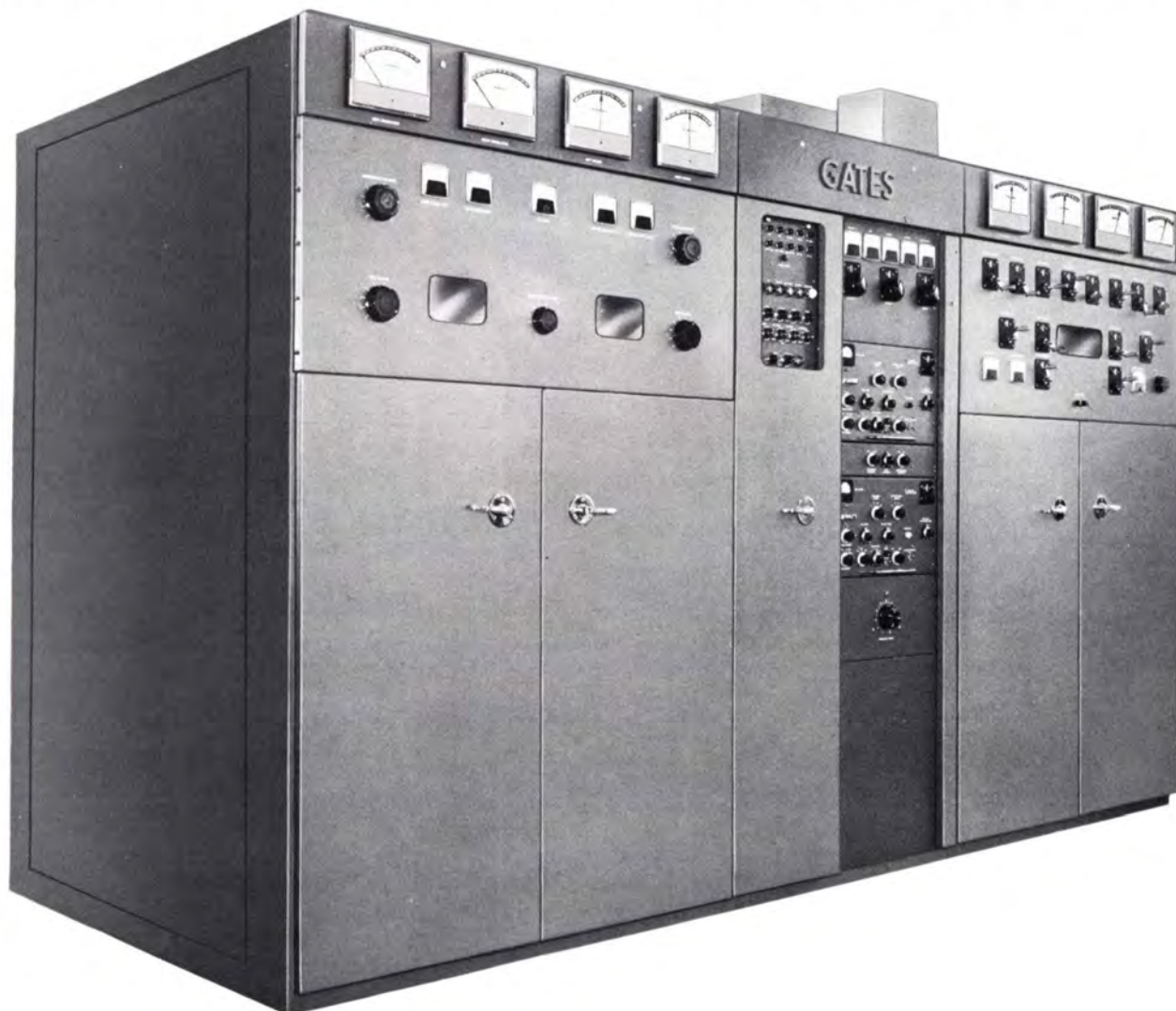

Gates high powered, high frequency broadcast transmitters have earned a world-wide reputation for reliable operation and unsurpassed signal quality.

Over thirteen 50,000 watt HF models are used by the Voice of America, including six at the world's largest transmitting plant in Greenville, North Carolina.

Gates' 41 years of experience in this field has produced high powered transmitters featuring rapid front panel tuning over the entire frequency range, high level modulation, air cooling, and compact size.

Silicon rectifiers are used throughout. External power components, including the modulation transformer, reactor,

and power transformer, are heavy duty type with field proven reliability.

Both 50 KW and 100 KW models for 50 or 60 cycle service are available.

The HF-50C, 50 KW HF transmitter is designed for operation between 3.9 mc to 30 mc, continuously variable. There are no coils or capacitors to change when tuning from one frequency to another.

Brochures are available on request describing in detail Gates HF broadcast transmitters for 50 and 100 kilowatts in the frequency range of 2-30 mcs.

## ORDERING INFORMATION

50,000 Watt Model.....	HF 50C
100,000 Watt Model.....	HF 100C



## 20,000 WATT HF BROADCAST TRANSMITTER

- 2-22 Mc quick frequency change
- 50-10,000 cycle response
- High level modulation
- Low cost tube complement
- World-wide climate design
- Also available in telegraph model

Another high power transmitter in the very complete line of Gates international broadcasting equipment that has a proven world-wide usage on every continent. Self-neutralized except power stage that uses four low cost 3X2500F3 tubes in push-pull. Audio system has four stages with high

level Class B modulation employing 3X3000F1 tubes. Four crystal positions. All stages continuously variable from front panel except power amplifier which has tray type quick change silver plated coil sets.

### ORDERING INFORMATION

For 20,000 watts broadcast ..... HF20B

For 20,000 watts telegraph ..... HF20TX

Complete data is available on request.

## 10,000 WATT 4-30 MC HF BROADCAST OR 15,000 WATT TELEGRAPH

A very new model in the Gates family of high frequency transmitters already in use in Government and private communications service. Certain design features make the broadcast model function excellently with the Kahn single side-band equipment. Available in a 10,000 watt broadcast or voice model and a 15,000 watt telegraph model. Spurious radiation is extremely low. Solid state rectifiers are used throughout. Employs only 21 tubes in all, with (2) 4CX5000 tubes in parallel as RF amplifiers and (2) 3X2500F3 tubes as Class B modulators in the broadcast/voice model.

Tuning is continuously variable from the front panel without coil change. Housed in four cabinets, only 8' 4" wide, 6' 6" high and 3' 4" deep for the broadcast model and is 100% self-contained. Telegraph model is in 3 cabinets 75" wide.

### ORDERING INFORMATION

10,000 watt Broadcast/Voice Model BHF-10B

15,000 watt Telegraph Model ..... THF-15

Data on this equipment available on request.

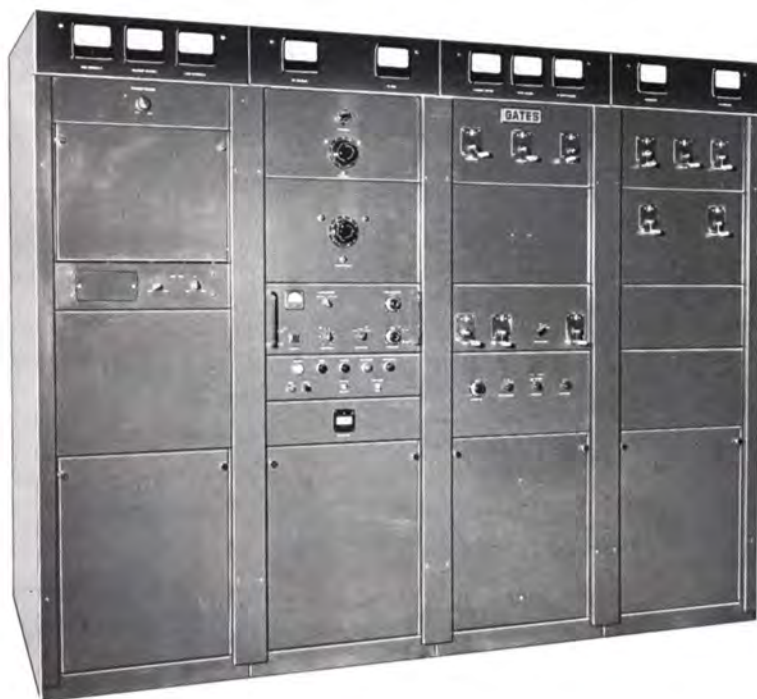

**GATES**

## 1KW, 2-30 MC HF BROADCAST (Continually Variable)

This remarkable 1000 watt short wave transmitter is for high quality AM broadcasting and is equally superb for telephone communication service. Continuous coverage over the entire high frequency range between 2-30 Mc is accomplished entirely by front panel tuning. There are no plug-in coils. Audio response is flat within  $\pm 1\frac{1}{2}$  db between 50 and 12,000 cycles. High level modulation assures consistent 100% modulation at the often varying conditions more peculiar to high frequency service. The HF-1M uses a single type 4-1000A power tube in the final amplifier and 2 type 833A tubes as modulators.

Five 4" meters at convenient console level provide unusual ease to quick tuning to any frequency. Important plate tank and loading tuning is by counter type controls for exact logging and quick return to any frequency. Primary: 230 volts, 3 wire, 50/60 cycles. Power output: 1100 watts maximum at any frequency at full 100% Class B modulation.

### MODEL HF 1M

Complete data covering this model is available on request.



## 5KW-10KW HF BROADCAST, TELEPHONE, TELEGRAPH

These two popular transmitters in 5,000 and 10,000 watt models will be found in Government and private commercial service around the world. They are most used as short wave broadcast transmitters but are also available in telegraph models only. Both models utilize 3X2500F3 low cost tubes in both RF power amplifiers and modulators.

Design is for world-wide service. Components withstand high humidity and temperatures or extreme dry cold climates with equal ease. Supervisory control, automatic recycling, multiple crystals and wide audio response are high spots of these outstanding professionals in the 5/10 KW field.

### BRIEF SPECIFICATIONS

- POWER OUTPUT:**  
5,000 watts HF5B  
10,000 watts HF10B
- FREQUENCY RANGE:**  
2-22 Mc
- AUDIO RESPONSE:**  
 $\pm 1.5$  db, 30-10,000 cycles.
- AUDIO DISTORTION:**  
3% or less, 50-7500 cycles.
- POWER INPUT:**  
230 volts, 3 phase, 50/60 cycles.
- RF OUTPUT IMPEDANCE:**  
300/800 ohms, balanced.
- RF STAGES:**  
Four.
- AUDIO STAGES:**  
Four.

### ORDERING INFORMATION

5KW Model ..... HF5B  
10KW Model ..... HF10B

Complete data is available on request.



**GATES**

## 2.5 KW SSB AMPLIFIER

The field proven HFL-2500 amplifier, in use by Military and Civilian Agencies, is designed for the rugged service encountered in transportable systems. It provides 2500 watts PEP and is continuously tunable over the frequency range of 2-30 MC by 4 controls on the front panel. It is the result of over two years' research. Compact, only 60" high, 22" wide and 24" deep and meets altitude requirements to 10,000 feet and world-wide humidity conditions. Automatic recycling, lower than industry standard distortion content and ability to retune to any frequency in less than two minutes are features incorporated in the HFL-2500 design.

The HFL-2500 amplifier delivers 2500 watts CW. Requires only 0.1 watt drive. Only 3 tubes used, including a 4CX3000A P.A. tube. Rectifiers are solid state.



### ORDERING INFORMATION

2500 watt SSB Amplifier.....HFL-2500

A complete brochure is available on request.

## 1 KW SSB AMPLIFIER

The most compact, rugged amplifier made today for either 1000 watts PEP or 1000 watts continuous CW operation. Size: 21" wide, 18 $\frac{1}{4}$ " deep and 24 $\frac{3}{4}$ " high. Continuously tunable between 2 Mc and 32 Mc with 4 front panel controls and will handle SSB, ISB, TSB, A1, A2 or A3 emissions. Amplifier rolls out to service, Designed for world-wide climactic conditions and 10,000-ft. altitude. Distortion products attenuated 35 db or better below either tone of standard two tone test. Uses 4CX1000A power amplifier and solid state rectifiers.



### ORDERING INFORMATION

1 KW SSB Amplifier.....HFL-1000

## RTS-100 SSB TRANSMITTER/RECEIVER

A modern 100 watt SSB transmitter and receiver combined for point to point service. Frequency range 2 Mc to 13.5 Mc. Four crystal controlled channels for simplex operation, or two crystal controlled transmitting channels with two separate crystal controlled channels for receiving. Only 19" wide, 12" high and 18 $\frac{1}{2}$ " deep. Matches antennas of 5-50 ohms resistive, 500-0 ohms reactive. Receiver squelch, speech clipper, audio for low level microphone input, and solid state rectifiers are all standard design.



### ORDERING INFORMATION

100 watt SSB Transmitter/Receiver.....RTS-100



## DIRECTIONAL PHASING EQUIPMENT

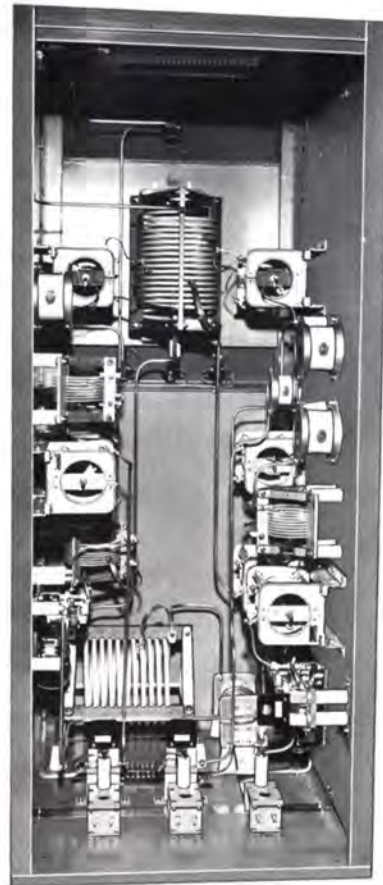

Gates is the world leader in the design and manufacture of phasing systems. For almost twenty years, Gates has been engaged in highly advanced phasor research and development, backed up by the largest full time phasor production department in the country. This department is made up of men specializing in the design and manufacture of the finest possible antenna phasing and antenna coupling equipment—under the complete supervision of a registered professional engineer. Gates not only designs and constructs phasors, but the majority of the components (coils, meter shorting switches, cabinets, major accessories) are produced in the extensive Gates phasing department. Our records indicate that Gates has produced half of all directional antenna phasing systems in use today . . . almost twice as many as all other manufacturers combined.

All directional antenna phasing equipment is designed in cooperation with the customer's consulting engineer, and work is not initiated until the consultant and customer approve the design.

Gates manufactures phasing equipment up to 100 kilowatts in power and for any number of elements. Prices are quoted promptly upon receipt of specifications. Many phasing systems can be quoted within one working day.

We invite your inquiry.

### A TYPICAL SET OF DIRECTIONAL ANTENNA PHASING SYSTEM SPECIFICATIONS

#### ANTENNA DRIVING POINT IMPEDANCE CALCULATIONS:

$$Z_{11} = 200 - j300 = Z_{22} = Z_{33} \quad Z_{12} = 45.0 / -120^\circ$$

$$Z_{13} = 67.5 / -37^\circ = Z_{23}$$

#### ANTENNA COUPLING UNIT RANGES AT INDICATED PHASE SHIFTS:

$$\text{Tower No. 1: } 41.6 \text{ to } 208 - j322$$

$$\text{Tower No. 2: } 52 \text{ to } 312 - j262$$

$$\text{Tower No. 3: } 52 \text{ to } 208 - j185$$

or

$$\text{Tower No. 1: } 96.85 + j110.5 \text{ to } -j530.5$$

$$\text{Tower No. 2: } 152.12 + j56.2 \text{ to } -j584.8$$

$$\text{Tower No. 3: } 105.122 + j47.8 \text{ to } -j593.2$$

#### PHASE SHIFT NETWORK RANGES:

$$\text{Line 1: } -85^\circ \text{ to } -115^\circ$$

$$\text{Line 2: } -55^\circ \text{ to } -85^\circ$$

$$\text{Line 3: } -55^\circ \text{ to } -85^\circ$$

#### OVERALL TRANSMISSION LINE EFFICIENCY:

$$\text{Common Point to Antenna } 99.3\%$$

$$\text{Transmitter to Common Point } 98\%$$

#### POWER DIVIDER DRIVING POINT IMPEDANCE RANGE:

$$13.55 \text{ to } 27.079 \pm j42.74 \text{ ohms}$$

#### MATCHING NETWORK RANGE:

$$\text{Matching } 52 \text{ ohms to } 13.55 + j47.08 \text{ to } -j59.92$$

$$\text{Matching ohms to } 27.092 + j50.3 \text{ to } -j56.7$$

#### COMPONENT RATINGS THROUGHOUT ABOVE RANGES:

$$\text{CURRENT: Greater than } 1.414 \text{ X maximum RMS}$$

$$\text{VOLTAGE: Greater than } 4.0 \text{ X maximum RMS}$$

# ANTENNA COUPLING UNITS

## ANTENNA COUPLER 1250 WATTS AND LOWER



A fully weatherproof coupler for series feed antennas to handle 1250 watts or less and at 100% modulation. Meter shorting switch is provided in antenna circuit to eliminate damage to meter during electrical disturbances. Antenna meter may be observed through glass porthole. Coil is silver plated, having generous inductance for arrangement in a full Tee network along with the fixed mica capacitors supplied. Extra room is provided in the cabinet for either

diode or thermocouple type remote metering kits.

### SPECIFICATIONS

- CARRIER POWER:**  
1250 watts or less.
- INPUT IMPEDANCE:**  
50 to 360 ohms concentric or open line.
- ANTENNA RESISTANCE:**  
10 to 1000 ohms.
- ANTENNA REACTANCE:**  
Plus J 600 to minus J 300 ohms from 540 to 1000 kc.  
Plus J 600 to minus J 500 ohms above 1000 kc.
- CIRCUIT:**  
Tee network.
- LIGHTNING PROTECTION:**  
Meter shorting switch.
- REMOTE METERING:**  
Provision for either thermocouple or diode type as ordered, at extra cost.
- SHIPPING WEIGHT:**  
98 lbs.
- SIZE:**  
20" high, 20 1/4" wide, 18 3/4" deep.

### ORDERING INFORMATION

**IMPORTANT:** State transmission line impedance, frequency, tower height and tower measurements if known.

Antenna Coupler with antenna meter ..... Model 44A

## HIGH POWER ANTENNA COUPLERS (50KW and 100KW)



For custom designed couplers in the 50,000 and 100,000 watt range, Gates can call upon a great deal of experience and skill. With a substantial supply of components on hand at all times there is a minimum of delay when designing a particular coupler.

Illustrated is a typical 100,000 watt shelf-type unit as employed in Sudan. All materials are of the highest possible quality and exact specifications are always met. Couplers are available in weatherproof cabinets if desired.

When ordering, please supply all available information such as (1) power, (2) frequency, (3) tower height, (4) ground conductivity if known, (5) tower measurements, if known, (6) transmission line impedance such as 50 ohms, 70 ohms, 250 ohms, etc., and whether coupler will be mounted in an out-building or if weatherproof type is desired.

Price of coupler can be quickly quoted with the above data supplied.

## 5-10 KW ANTENNA COUPLING UNITS

These two nearly identical models differ only in component size for 5 and 10KW power ratings. Housed in an aluminum cabinet with double front doors. Size: 38" high, 37" wide, and 21 1/2" deep. Antenna meter may be observed and meter shorting switch operated with the inner door closed. Coils are silver plated. Capacitors have generous voltage and current safety factor. All ratings are 100% modulated. Tuning unit may be mounted by metal flanges at each back side. Usually two wooden poles, set in the ground, are used for mounting. A large lead in bowl is provided for antenna connection.



### SPECIFICATIONS

- FREQUENCY RANGE:**  
540-1700 kc, as ordered.
- INPUT IMPEDANCE:**  
45-360 ohms, as ordered.
- ANTENNA RESISTANCE:**  
20-1000 ohms.
- REACTANCE:**  
+J500 to -J500.
- WEIGHT:**  
Packed, 315 lbs. (export); 200 lbs. (domestic).  
Unpacked, 136 lbs. Cubage, 24.

### ORDERING INFORMATION

**IMPORTANT:** When ordering, state carrier frequency, transmission line impedance, tower height and tower resistance measurements if known.

Coupling Unit for 5KW ..... M-5309A  
Coupling Unit for 10KW ..... M-5309B

## SERIES AND SHUNT FEED COUPLERS



Model M-5178: Series feed, provides all coil capacitance to provide full Tee network. Constructed in non-weatherproof steel cabinet, front removable. Size: 21" high, 10" wide, 9" deep. Matches RF input of 50 or 70 ohms. Output 10-600 ohms. In this model metering is external to the coupler, often desirable in unattended operation. For all powers 100% modulated up to 1250 watts carrier.

Antenna Coupler ..... Model M-5178

Model M-5179: Shunt feed coupler of coil and capacitor combination to tune out the reactance in shunt fed antenna coupling. Same size as M-5178

above. Rating up to 1250 watts carrier 100% modulated.

Antenna Coupler ..... Model M-5179

**IMPORTANT:** Please state frequency, tower height and tower measurements, if known

**NOTE:** Meter not included.

# TOWER CHOKES—ISOLATION COILS—SAMPLING LOOP



Fig. A

## SOLENOID TOWER CHOKES

Most popular of all tower light isolation chokes. Available in 2 or 3 section and in open type, illustrated to right, or weatherproof type, illustrated to left. Wound on XX heavy bakelite tubing with mica-by-pass condensers on each circuit end. Inductance 350 uh. 3" stand-off insulators are part of coil. Size: choke only, 18½" long, 5" diameter, 7½" from bottom of insulator to top of coil. Weatherproof type, 24" high, 17¾" wide, 10¼" deep. Illustration to left shows front cover of weatherproof unit removed for photographing.

M-3937, 2-section, Fig. A  
M-3938, 3-section, Fig. A

M-3935, 2-section, Fig. B  
M-3936, 3-section, Fig. B



Fig. B



## ISOLATION COIL

Inductance 85 uh. Made to order in any available type coax as specified and mounted on heavy bakelite bars. Available in weatherproof model illustrated above (front cover removed) or coil only for mounting inside tuning house. Size (weatherproof model): 20" wide, 32½" high, 18½" deep. State carrier frequency and power when ordering. Includes all necessary elements to match purchaser's frequency.

Weatherproof isolation unit ..... M-3073  
Coil only, less cabinet ... M-4561A  
Weatherproof isolation unit with M-5573 coil (shown below) ..... M-5634

## AUSTIN RING TYPE TOWER CHOKE

Ring type tower choke is a transformer with clear air space between primary and secondary and resultant zero RF leakage. Independent of frequency. All models are for 115/230 volt primary and 115 volt secondary. Base insulator in photo for illustration purposes only.



Type	Capacity KVA	Mfg. Style	Net Wt. Lbs.	Attachments
A-2100	1 — 1.75	Side Bracket	81	none
A-2101	1 — 1.75	Side Bracket	85	Lt. gap
A-2102	1 — 1.75	Pedestal	82	none
A-2103	1 — 1.75	Pedestal	86	Lt. gap
A-1970	2 — 3	Side Bracket	188	none
A-1971	2 — 3	Side Bracket	201	Lt. gap
A-1972	2 — 3	Pedestal	182	none
A-1973	2 — 3	Pedestal	200	Lt. gap

## REMOTE METER KITS

### M-6112 R.F. DIODE

Designed primarily for the remote indication of antenna current. It is not necessary to break the lead to the antenna to install unit. The M-6112 RF Diode consists of a pickup loop attached to a solid state rectifier assembly through a short length of coaxial cable. The loop is clamped to the antenna lead. The scale range of the recommended indicating meter is determined by the requirements of the installation. The meter should be a 1 ma. D.C. movement. No AC power is required.

### SPECIFICATIONS

#### POWER RANGE:

250 to 50 Kw.

#### FREQUENCY RANGE:

540 to 1600 Kc.

Solid state diode assembly for all powers 250 watts thru 50 KW. M-6112



FIG. A



FIG. B

METERS: Figure B. Available in all common ranges—3 or 4 inch size. Other scales available on special order.

REMOTE METER KITS: Thermocouple Type: Fig. C. Includes 3" square case meter, thermocouple, adjusting rheostat, chokes and capacitors. May be used with up to 1000 ft. of 2C No. 18 or larger line for remote metering between tuning house and transmitter.

Complete (meter range 0-3 RFA) ..... M-3383  
Complete (meter range 0-5 RFA) ..... M-3133  
Complete (meter range 0-10 RFA) ..... M-3386



FIG. C

## M-5573 ISOLATION COIL



Coil only ..... M-5573

Used in the same manner as the M-3073 and M-4561 shown above. The coil is wound of RG-11/U or RG-8/U as ordered. Has an inductance of approximately 100 uh. Where the consulting engineer wishes to resonate the coil, a separate capacitor is required.

## PHASE SAMPLING LOOPS

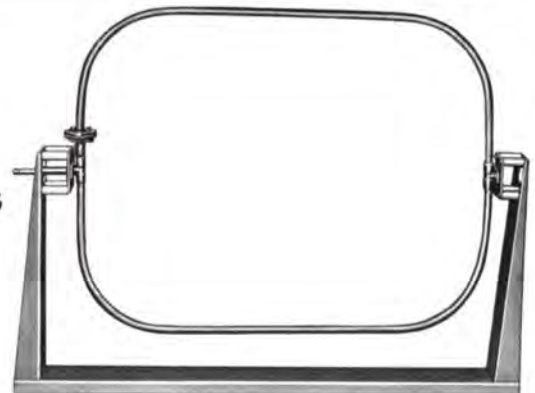

M-3283: This model especially applicable where high current ratios are to be sampled. May be rotated so that phase monitor amplitude values are nearly equal. Electrostatically shielded and insulated from tower. May be used with or without isolation coil at base of tower. Coil is single loop of 7/8" coaxial cable, heavily insulated from base frame. Matches either 50 or 70 ohm line. Size: 48" wide, 32" high.  
Sampling Loop ..... M-3283A

# BROADCAST FREQUENCY MONITOR

## Model M-4990

The M-4990 Frequency Monitor is fully FCC approved for use between 540 and 1600 KC.

A vacuum type crystal unit, precise to broadcast transmitter standards without temperature control, is mounted with its oscillator stage components within a carefully designed temperature controlled chamber to result in 1/2 part per million frequency accuracy.

A precision oscillator operates 1000 cycles below the carrier frequency. The output from the oscillator is isolated and amplified and then mixed in a detector stage with the radio frequency signal from the transmitter. This signal may be direct connected or when used in remote control (unattended) operation, the M-5549 whip antenna kit may be purchased for direct air monitoring over distances of 20 miles or more, depending on the transmitter power. The beat note from the detector is amplified and then applied to a discriminator. The output is rectified and applied to a DC meter calibrated in 1-cycle steps from -30 to +30 cycles.

The meter may be switched to several circuits including carrier level, frequency deviation, oscillator current and local/remote functions. Outstanding features are—accuracy over a wide range of input voltages, greater reliability, smaller size and laboratory standard performance.



Front panel hinges down to expose operating adjustments and the plug-in crystal unit. Here is exhibited the uniformity of printed wiring to produce uniformity in year-in and year-out service.

### SPECIFICATIONS

- OSCILLATOR:**  
Electron coupled 1000 cycles below assigned frequency, crystal control.
- FREQUENCY RANGE:**  
540-1600 Kc as ordered for one specified frequency.
- DEVIATION RANGE:**  
Meter reads -30/0/+30 cycles.



**INPUT VOLTAGE:**

Supplied with external fixed pad to handle wide range of input voltages from 5-50 volts direct connected and down to 5 Mv with whip antenna.

**INPUT SIGNAL:**

Modulated or unmodulated.

**INPUT IMPEDANCE:**

50/70 ohms.

**OVERALL STABILITY:**

± 2 parts in one million.

**OSCILLATOR STABILITY:**

± 0.5 parts in one million.

**LINE VOLTAGE:**

105-125 volts, 50/60 cycles at 85 watts.

**TUBES:**

12BY7A oscillator, 6AU6 oscillator amplifier, 6AU6 input amplifier, 6C4 mixer, 6AP6 audio amplifier, 6AU6 limiter, 6AQ5 cathode follower, 12AT7 AVC, 6AL5 discriminator rectifier, 6AL5 VTVM rectifier, 6X4 high voltage rectifier, 6AQ5's Series regulators, 6AU6 voltage amplifier, OB2 voltage reference, 13-4 Ballast.

**SIZE:**

19" wide, 10 1/2" high, 10 5/8" deep.

**FINISH:**

Medium gloss gray.

**WEIGHT:**

32 lbs. net, 53 lbs. packed. Cubage 4.

**FCC TYPE APPROVAL NUMBER:**

3-102.

### ORDERING INFORMATION

- Frequency monitor with tubes and crystal,  
state frequency when ordering ..... M-4990
- 100% spare tube complement ..... TK-281
- Remote frequency meter, reading -30 to +30 cycles, mounted  
on 5 1/4" x 19" rack panel finished in gray ..... M-5631
- Whip antenna with coupler to match RG/59U cable and monitor M-5549





# BROADCAST MODULATION MONITOR

Model M-5693



For the first time, since the introduction of the modulation monitor for AM broadcasting stations over a quarter-century ago, Gates offers a totally new monitor design, manufactured exclusively under the U.S. Patent No. 2,984,796. Gates M-5693 modulation monitor has advantages which afford unexcelled, long term accuracy. This results in assured maximum modulation and erases the need for down-rating of the modulation monitor readings to protect against over-modulation. The result is maximum utilization of signal strength capabilities of the broadcast transmitter.

Modulation monitor accuracy is retained even as the tubes age. A new derivative controller circuit provides high speed meter response that will indicate even the fastest transient program peak. Correct peak indications on single program pulses as short as 50 milliseconds assure true peak measurement of program amplitude regardless of wave forms encountered.

The flashing over-modulation light indicator is directly calibrated. It has the same superior accuracy as the meter. As all measuring circuits are direct coupled to the detector output, carrier shift has no adverse effect on meter readings. It is said that measuring modulation under program condi-

tions is more accurate in the Gates M-5693 monitor than that of an oscilloscope and, of course, is much simpler to use. As a result, it is unsurpassed for making proof of performance measurements.

All controls are located on the front panel except the calibration and power switch controls, which are conveniently located behind a small drop-down front panel. Exclusive is the ability to calibrate the monitor quickly and easily without the use of any other test or measuring instrument.

Also included in the new Gates M-5693 monitor are controls for compensation of varying telephone line characteristics to permit location of the monitor at the transmitter site. Operation by remote control is then initiated by Gates optional M-5837 remote meter panel. Maximum accessibility has been emphasized, as is characteristic of all Gates equipment. The drop-down front panel permits nearly all maintenance and servicing operations, as required, from the front and every part can be reached in a matter of seconds.

Finish is in Gates gloss gray with escutcheons, knobs and meter cases in black.

## M-5693 BROADCAST MODULATION MONITOR



Rear View.

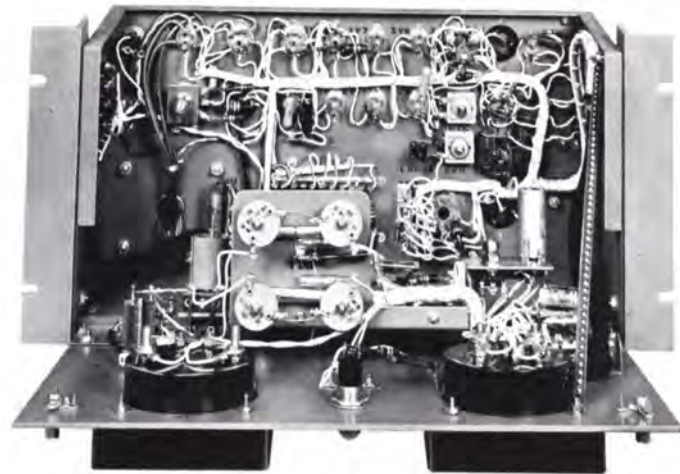

Front Panel Hinges Down for Complete Accessibility.

### SPECIFICATIONS

**FREQUENCY RANGE:**

540-1600 Kc.

**RF INPUT IMPEDANCE:**

Matches 50-75 ohm lines.

**RF INPUT LEVEL:**

Approximately 10 volts.

**MODULATION RANGE:**

Meter: 0% to 100% on negative peaks.  
0% to 110% on positive peaks.

Flasher: 50% to 100% on negative peaks in steps of 5%.

**RESPONSE:**

Meter: Within 0.2 db 50-15,000 cycles.

Flasher: Within 0.6 db 20-7500 cycles.

**ACCURACY:**

Meter: 2% of full scale at 1000 cps. for any percentage of modulation.

Flasher: 2% at 1000 cps.

**RESPONSE TIME:**

Meter: Meter responds to correct reading with a 50 millisecond pulse of modulation. Needle returns to 10% of reading in 500-800 milliseconds after signal is removed.

Flasher: 15 milliseconds.

**DETECTOR LINEARITY:**

Negative peak clipping is negligible for frequencies up to 7500 cps and 5% or less at 10,000 cycles.

**MONITORING OUTPUT:**

When feeding a 600 ohm unbalanced load:

Level: -20 dbm at 100% modulation.

RESPONSE:  $\pm 0.2$  dbm from 50-15,000 cycles.

DISTORTION: Less than 0.25% from 20-15,000 cycles.

NOISE: At least 65 db below maximum output of -20 dbm.

When feeding an open circuit (grid):

LEVEL: 0.75 volts R.M.S. at 100% modulation.

RESPONSE:  $\pm 0.2$  db from 50-15,000 cycles.

DISTORTION: Less than 0.1% from 20-15,000 cycles.

NOISE: At least 60 db below maximum output of 0.75 volts.

**LOADING EFFECT:**

1000 mmf (12 ft. of single conductor shielded cable rated at 85 mmfd per ft.) at 15,000 cycles is about 0.1 db.

**FIDELITY MEASURING OUTPUT:**

RESPONSE:  $\pm 0.5$  db from 20-30,000 cps.

DISTORTION: Less than 0.5% at 4.5V. in 100,000 ohm load.

NOISE: 75 db below maximum output of 4.5 volts R.M.S.

**POWER SUPPLY:**

105 to 125 volts, 50/60 cycles.

**POWER CONSUMPTION:**

70 watts.

**AUXILIARY OUTPUTS:**

Remote connections for percentage modulation meter.

**TUBES:**

(2) 12B4A, (3) OA2, and (1) each—6X4, 5879, OB2, OC2, 5687, 12AU7, 2D21, 8-4.

**SIZE:**

Rack mounted, 19" x 8 $\frac{3}{4}$ " panel, 11 $\frac{1}{2}$ " depth behind panel.

**WEIGHT:**

25 lbs.

**FCC APPROVAL NUMBER:**

3-109.

EXCLUSIVELY LICENSED UNDER U.S. PATENT NO. 2,984,796.



Remote Meter Panel M-5837.

### ORDERING INFORMATION

Modulation monitor, complete with tubes	M-5693
100% set of spare tubes	TK-345
Remote meter panel	M-5837



# DELUXE MODULATION MONITOR

Model M-5774A



## DELUXE MODULATION MONITOR MODEL M5774A

The Gates M-5774A amplitude modulation monitor, operating on an entirely new principle, is designed to give the most reliable indication of modulation percentage of any present day type. It was developed specifically for use with broadcast and communications transmitters in the 2 to 30 MC band, and as a deluxe unit for the standard broadcast band.

Meter and overmodulation lamp circuits can be calibrated in seconds while you are broadcasting without any external test equipment and entirely independent of the associated transmitter. You need no oscilloscope or tone modulation to check and correct accuracy. This remarkable feature assures errorless measurements over the years, regardless of tube changes and parts replacement. The patented derivative controller meter circuit enables rapid response—even the shortest transient program peak is correctly indicated. The detector is dc coupled to the measuring circuits to avoid errors when transmitted waveforms are unsymmetrical.

## DELUXE MODULATION MONITOR MODEL M-5774

This deluxe monitor is identical to model M-5774A, except for response speed of the meter. The derivative controller circuit affords the fastest response time of any modulation monitor available. Foreign broadcasters, Government agencies, laboratories and others, not restricted by FCC regulations on maximum meter speed, can achieve the ultimate in modulation measurement accuracy with this version. All specifications for Model M-5774 are the same as the M-5774A except response time, which should read: **RESPONSE TIME:—METER**—Meter responds to 90% of correct reading with a single 15 millisecond pulse of modulation. Needle returns to 10% in 1100 to 1400 milliseconds after signal is removed.

### SPECIFICATIONS

- FREQUENCY RANGE:**  
540-1600 KC and 2-30 mc.
- RF INPUT IMPEDANCE:**  
Approximately 75 ohms.
- RF INPUT LEVEL:**  
Approximately 14 volts.
- MODULATION RANGE:**  
Meter—0% to 100% on negative peaks. 0% to 110% on positive peaks.  
Flasher—50% to 100% on negative peaks in steps of 5%.
- RESPONSE:**  
Meter—Within 0.2 db 50-15,000 cycles.  
Flasher—Within 0.6 db 20-7500 cycles.

### ACCURACY:

- Meter— $\pm 2\%$  full scale at 1000 cps. for any percentage of modulation.  
Flasher— $\pm 2\%$  of full scale dial calibration at 1000 cps.

### RESPONSE TIME:

- Meter—Meter responds to 90% of correct reading with a single 50 millisecond pulse of modulation. Needle returns to 10% of reading in 500 to 800 milliseconds after signal is removed.  
Flasher—Responds to a 15 ms pulse of modulation and remains on for about 1/5 second.

### CIRCUITS:

- Meter—(1) Direct coupled amplifier responds correctly to any modulation wave form.  
(2) High speed meter circuit.  
(3) Self-calibration without external equipment.  
Flasher—(1) Direct coupled flasher shows accurately negative peaks of modulation regardless of waveform.  
(2) Flasher uses a DC plate supply, permitting all over-modulation peaks to be indicated.  
(3) Self-calibration.

### DETECTOR LINEARITY:

- Negative peak clipping in the detector is negligible for frequencies up to 7500 cps. and does not exceed 5% at 15 kc and 100% modulation.

### MONITORING OUTPUT: When feeding a 600 ohm unbalanced line:

- Level—20 dbm at 100% modulation.  
Response— $\pm 0.2$  db from 50 to 15,000 cycles with 1000 cycles reference.  
Distortion—Less than 0.25% from 20-15,000 cycles, (not including detector distortion).  
Noise—At least 65 db below maximum output of 20 dbm.

### POWER SUPPLY:

- 105 to 125 V. (or 115 to 135 V.) 50/60 cycles. Power consumption is 100 watts.

### AUXILIARY OUTPUTS:

- Connections at the rear of the instrument for an external modulation meter, negative peaks lamp and distortion analyzer.

### TUBES:

- (1) GZ34/5AR4 (type 5R4-GY and 5V4G are directly interchangeable). (1) 6080, (1) 5879, (6) OA2, (2) OB2, (1) 2D21, (1) OC2, (1) 12AX7, (1) 5687, (1) 12AU7, (1) 8.4.

### MOUNTING:

- Rack mounted 19" x 8 $\frac{3}{4}$ " panel, 11 $\frac{1}{2}$ " depth behind panel.

### WEIGHT:

- 27 lbs. net.

### FCC APPROVAL NUMBER: 3-108.

### ORDERING INFORMATION

- Modulation monitor, complete with tubes ... M-5774A  
Modulation monitor, complete with tubes ... M-5774  
100% set of spare tubes ..... TK-346  
Remote meter panel ..... M-5836B

## TRANSMITTER CONTROL CONSOLE

For use with any standard or short wave broadcast transmitter to provide several input circuits, extension audio indicating meters, remote start/stop functions and associated indicator lamps. Can be supplied for use with high powered 50KW or 100KW transmitters.

### SPECIFICATIONS

**INPUTS:**  
Three provided with line isolation transformer for each circuit.

**OUTPUT:**  
600 ohms.

**MASTER GAIN:**  
Balanced 30 steps, 1.5 db per step.

**VU METER:**  
4" square case with range control.

**MODULATION METER:**  
4" square case illuminated.

**PUSH BUTTONS:**  
Four pairs provided.

**PILOT LIGHTS:**  
Provided to indicate filament and plate on.

**FINISH:**  
Medium hand rubbed gloss gray with escutcheons in black.

**SIZE:**  
24" wide, 10" high, 21½" deep.

**SHIPPING WEIGHT:**  
60 lbs.

### ORDERING INFORMATION

Model CCD2, Speech Input Console ready to install.....M-4055



## PHASE MONITOR

The Clarke 108E is recognized as the finest phase meter built today.

### SPECIFICATIONS

**FREQUENCY RANGE:**  
100 Kc to 2000 Kc (as ordered).

**PHASE ANGLE RANGE:**  
0-360 degrees.

**MONITORING ACCURACY:**  
1 degree.

**RESOLUTION:**  
½ degree.

**RF INPUT IMPEDANCE:**  
50 or 70 ohms (as ordered).

**SIZE:**  
14" high, 19" wide, 7" deep.

**POWER:**  
115 volts, 50/60 cycles, 80 watts.

**TUBES:**  
(2) 6AU6, (2) OB3, (3) 6AL5, (1) 5Y3.

When Ordering: State carrier frequency, remote meter ranges, type of sampling line or impedance, carrier power and number of towers.



## FM MONITOR

Made by Hewlett-Packard and FCC approved for measuring frequency and modulation percentage of standard FM broadcasting stations with ±75 Kc swing. Very popular and used in scores of laboratories. Be sure to state frequency when ordering. Panel size: 10½" x 19", for 115 volts, 50/60 cycles.

### ORDERING INFORMATION

FM Monitor ..... 335BR



## FIELD INTENSITY METER

The Clarke 120E field meter is for measurement of radio signal intensity in the broadcast band between 540-1600 Kc. For measurements of any directional system or signal intensity, this test instrument is indispensable. The 120E meter is battery operated, weighs only 12½ lbs.

### SPECIFICATIONS

**FREQUENCY RANGE:**  
540-1600 Kc.

**FIELD INTENSITY RANGE:**  
10 microvolts to 10 volts per meter.

**ACCURACY OF ATTENUATORS:**  
2%.

**OUTPUT INDICATORS:**  
Panel meter, direct reading. Provision for using recorder and headphones.

**BATTERIES:**  
Five 1½ volt A. Two 67½ volt B.

**BATTERY LIFE:**  
Approximately 500 indications.

**TUBES:**  
(4) 1T4, (2) 1R5.

**SIZE:**  
9" high, 13" wide, 5¾" deep (closed).

### ORDERING INFORMATION

Field Meter, less batteries.....Model 120E

NOTE: As standard batteries are employed, it is recommended that batteries be procured locally as needed.



**GATES**

# REMOTE CONTROL SYSTEM

## RDC-10AC



The RDC-10AC meets FCC requirements for remote control of AM and FM broadcast transmitters. It is the most widely used control system for unattended operations.

**Functions:** The RDC-10AC equipment provides: (a) 10 possible metering positions, (b) 23 possible control functions, (c) relay switching of both filament and plate and meets full Conelrad requirements, (d) constant voltage source is provided for line checking, and (e) metering positions are rotary switch selected, requiring no dialing. Fail-safe protection is provided on the filament control circuit. Up to 18 added switching functions may be handled by the choice of many accessories listed in this catalog.

**Metering:** Three 4" large scale meters calibrated in; (a) DC plate volts, (b) DC plate current, and (c) RF amperes. Plate voltage and plate current sampling units for transmitter installation, are supplied (see Ordering Information for list of items supplied).

**Installation:** The studio unit may be rack, desk or wall mounted. The panel size is 8 $\frac{3}{4}$ " x 19" and power is self-contained. The transmitter unit is also 8 $\frac{3}{4}$ " x 19" and is usually mounted in the rack cabinet associated with the transmitter. At the transmitter, the plate current and plate voltage extension units for remoting these FCC required meters are connected in the meter circuit with a pair from each extension unit, returned to the RDC-10AC transmitter unit. In transmitters of 1000 watts power or less, the motor tuned plate rheostat is installed in the transmitter in series with existing rheostat in the transmitter and also connected to the RDC-10AC transmitter unit. For remote antenna current reading, diode rectifier is used and supplied with some models (see Ordering Information). The tower light indicator is a small current transformer and remotes back to one of the meters at the studio unit, indicating On-

Off and pulses in beacon flashing, as well as the steady current of the obstruction lights. Two telephone lines are used between studios and transmitter. However, one of these lines may be used for order telephone service also. **Remote Monitoring:** Several Gates accessories are available for remote monitoring. For AM, extension meters are used with both the frequency and modulation monitors while the monitors remain at the transmitter. For FM, a radio frequency amplifier is available for "off air" pickup to operate the monitors. The monitors are then installed at the studios. Gates will gladly assist in the selection of proper accessories for different types of monitors.

**General Engineering Information:** The RDC-10AC systems is a DC system and does not employ tubes or transistors. Solid state rectifiers are used for DC circuits. Design is based on a maximum telephone line loop resistance of 3000 ohms, or based on 96 ohms resistance (maximum) per mile, the RDC-10AC system may be used on good lines up to 30 miles. However, where the entire length of the telephone line is in cable, i.e., many lines in one cable, wherein capacity would increase, the maximum length is about 20 miles. As the usual line from studio to transmitter is much shorter, this is unimportant. The stepping relay, heart of the system, is a well-known telephone type used in dial systems and has gold plated contacts for trouble-free operation. The hinged down front panels for servicing of both transmitter and studio units will be appreciated by the engineer. Power source is 115 volts, 50/60 cycles. The RDC-10AC system is FCC approved.

**Directional Operation:** For most directional stations, the RDC-10AC system will be most adequate. For complex directional systems the Gates Model RDC-200A provides the expanded facilities which may be needed.

## RDC-10AC REMOTE CONTROL SYSTEM

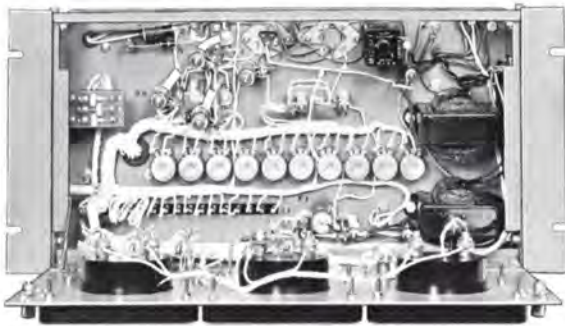

Studio unit has drop-down front panel so all parts can be reached from front of rack. Panel size of 8 3/4" x 19" conserves much needed rack panel space.



The transmitter unit has drop-down front panel for service and requires only 8 3/4" x 19" panel space. Small size even allows mounting in some transmitters where room prevails. Local-remote switch permits transfer of control to transmitter site for maintenance or servicing.

### ORDERING INFORMATION

(A) RDC-10AC basic unit includes studio and transmitter units and also Items I, J and K below	M-5862
(B) Antenna diode unit for all points up through 50 KW AM	M-6112
(C) Motor/rheostat assembly for 250 watt transmitter	M-4703A
(D) Motor/rheostat assembly for 500 watt transmitter except Gates BC-500G	M-4703B
(E) Motor/rheostat assembly for 1000 watt transmitter except Gates BC-1G	M-4703C
(F) Motor control unit for plate rheostat in BC-500G and BC-1G transmitters	M-6326
(G) Motor assembly for tuning variable connector or coil power adjustment of 5KW or 10KW transmitters in output coupling circuit (must be used with H below)	M-5066
(H) Relay assembly to control M-5066 motor	M-4806
(I) Plate current unit, extends plate current reading	M-4720A
(J) Plate voltage unit, extends plate current reading	M-4719A
(K) Tower light indicator	M-5146

**WHEN ORDERING:** Please give as much detail as possible such as make of transmitter, size of plate rheostat in ohms and watts and any helpful peculiar information. For higher powers, order by item and not packages. See catalog index for other accessories for both AM and FM. If you don't have one, we will gladly send a copy to you on request.

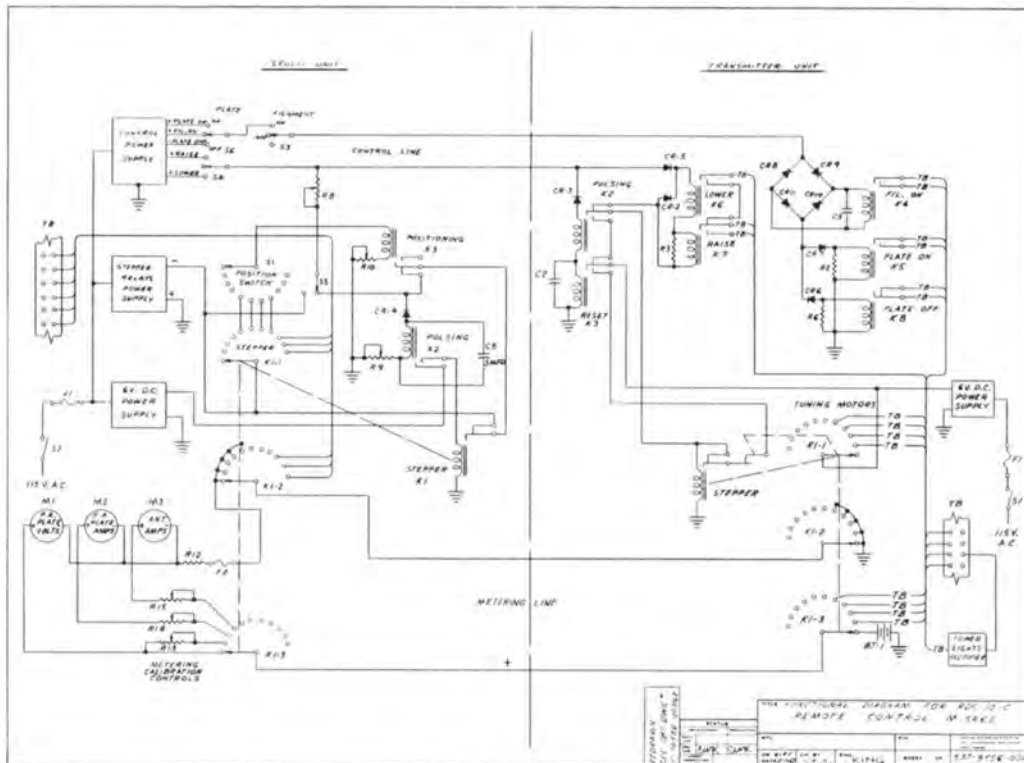

# DELUXE REMOTE CONTROL SYSTEM

## Model RDC-200A



Studio Unit



Transmitter Unit

This system will handle the complicated directional system and several transmitters and provides the utmost in dependability for any transmitter power up to 50,000 watts.

Model RDC-200A is an advanced design of a DC operating system. Simplex, phantom or natural ground returns are eliminated in favor of a straight wire return. Two wire pairs are the maximum requirement for any demands placed by one or several transmitters, directional operation and tower light indication. With this system, wire lengths of as much as 60 miles provide no problem.

Highest current drain of any switching function is 6 MA, making the system almost impervious to line resistance change. These additional features will be of interest:

1. A total of 39 metering positions—9 for internal metering (calibrated), plus calibrate position, 9 more for external metering (calibrated) and 19 external meters (not calibrated) for "off-on" indications. (These may

be calibrated with internal or external potentiometers.) 1 meter for power light indication is also provided.

2. As wired, provides 78 switching circuits.
3. All necessary equipment for one transmitter is standard equipment. Includes: (a) plate current metering unit, (b) plate voltage metering unit, (c) plate voltage on-off relays, and (d) tower light indicator with current transformer. There are optional accessories for every need. Your inquiry is invited.
4. 100% front panel accessibility via drop-down front panel. Panel size: 19" x 15 $\frac{3}{4}$ ".

All of the standard demands of complete remote control equipment will be found in the Gates RDC-200A meeting FCC requirements including fail safe. Transmitter and studio units have self-contained power supplies and are independent operating units.

### ORDERING INFORMATION

RDC-200A complete deluxe remote control system ..... M-5870

# REMOTE CONTROL ACCESSORIES

## FREQUENCY MONITOR EXTENSION METERS



Used for extending Gates M-2890 monitors. Has 4" frequency indicating meter reading 30-0-30 cycles. Includes resistor pad for sampling voltage. Tubes: 6AW6, 6AQ5, 6AL5, 6X4 and OA2. For 115 volts, 50/60 cycles.  
Size: 7" x 19" x 7" deep.

Frequency monitor extension unit M-5270  
FOR M-4990 FREQUENCY MONITOR  
Meter is exact duplicate of the M-4990 monitor for extending frequency indication to studios.  
Extension meter M-5631

## MONITOR EXTENSION METERS



Several types available as listed below for extending both frequency and modulation monitors. Mounted on standard 19" rack panel 5 1/4" high.  
Remote meter for extending Gates M-5693 modulation monitor M-5837  
For extending Gates M-2639 modulation monitor M-5210  
For GR1931A or RCA WM43A modulation monitors M-5206  
For GR1181A or RCA WF48A frequency monitors M-5208  
For RCA 66 Series monitors M-5207  
For RCA 311A monitor M-5209

## RF FM AMPLIFIER M-4791



Operates with any approved FM frequency/modulation monitor where the signal is taken off the air and monitor is at studio. Amplifier supplied fixed tuned to your frequency. Power supply is not supplied. Requires 300 volts DC at 100 MA and 6.3 volts AC at 3 amperes.

SIZE: 7" x 19" x 8" deep.  
TUBES: 6AK5, 6BA6, 6AH6, 2E26, OA2.  
RF FM Amplifier with tubes M-4791  
PWR-3 Power Supply M-5000A  
BA-21 Base for PWR-3 M-4619



## MOTOR OPERATED RHEOSTAT

Recommended for regulating the plate voltage in transmitters of 1 KW and less. Available in three sizes for 250, 500 and 1000 watt transmitters. Motor is one RPM and operates from 115 volts, 60 cycles.

Motor Rheostat for 250 watts M-4703A  
Motor Rheostat for 500 watts M-4703B  
Motor Rheostat for 1 kw M-4703C  
Motor Control for Rheostat in BC-500G and BC-1G M-6326



## RELAY ASSEMBLY

For controlling motors. Usually used where transmitters already incorporate tuning motors. Used with M-5066 tuning motor. As listed below, designed for control of one 3-wire motor or one 5-wire motor.

For 1 3-wire motor M-4801  
For 1 5-wire motor M-4806

## FM OUTPUT INDICATOR

Designed to sample the 51.5 ohm transmission line of an FM transmitter for measuring transmitter output as required by FCC. Provides a DC voltage which is measured on the studio unit meter system. Solid state device requires no AC power.



FM Output Indicator M-4845



## TUNING MOTOR

This unit for tuning variable inductor, capacitor or other controls, has inbuilt limit switches. Five wire reversible motor 1 RPM. Requires M-5806 relay assembly for control, 115 V. 50/60 cycles.  
Tuning Motor M-5066

Complete kit to control output loading of Gates BC-5P-2 5-KW transmitter. It includes M-5066 and M-4806 relay and all necessary mounting hardware.  
Output Loading Control Kit M-4848A



## M-6112 RF DIODE UNIT

The M-6112 RF diode is designed for use as a remote R.F. indicating device in standard broadcast installations for sampling base currents or common point currents. It is not a directly calibrated R.F. ammeter, but is linearity with the adjustable to indicate current R.F. meter.

It is not necessary to break the lead to the antenna to install the unit. The M-6112 RF diode consists of an inductive loop attached to a rectifier assembly is clamped to the antenna lead. The M-6112 is a solid state device and requires no AC power.  
Power Range: 250 to 50 Kw.  
Frequency Range: 540 to 1600 Kc.  
RF Diode Unit M-6112

## AC RECTIFIER

Rectifies the AC voltage, either line or filament, at the transmitter and feeds back DC to studio unit for measuring AC by remote control.

AC Voltage Unit M-4825



## OUTPUT LOADING CONTROL KIT

Complete kit to control output loading of Gates BC-5P-2 5-KW transmitter. It includes M-5066 and M-4806 relay and all necessary mounting hardware.  
Output Loading Control Kit M-4848A

## PLATE CURRENT UNIT

Included with the Gates Remote Control System. Furnishes a sample of plate current which is returned to the studio unit and measured on the directly calibrated plate current meter. The unit is provided with a high voltage fuse for personnel and line protection, and can be used for current ranges of .8 ampere and 3 amperes. Units can be used in parallel if higher current range is required.

Plate Current Unit M-4720A

## TUNING MOTOR ASSEMBLY

For operating rheostat, variable condenser, or any variable control. Three wire reversible motor 1 RPM. Torque 15 lb. inches. 115 volts, 50/60 cycles.  
Tuning Motor M-4800

## OVERLOAD RELAY

Replaces circuit breakers in current or older models as circuit breakers are usually undependable for remote control. Tripping current adjustable. Inserted in cathode circuit of RF power amplifier. Some engineers prefer an additional unit in modulator circuit.

Overload Relay M-5129



## AUXILIARY RELAY ASSEMBLY

Auxiliary relay assembly to provide one on-off momentary switching facility. These relays provide two sets of double throw double contacts rated at 8 amperes.

Auxiliary relay assembly M-5249  
Same as above but latching (holding) type with 5 ampere contacts M-5248



## TOWER LIGHT UNIT

This unit is used to provide a DC voltage for indication of proper tower light operation. Includes current transformer.  
Tower Light Metering Kit M-5145

## SPECIAL EQUIPMENT FOR REMOTE CONTROL

Gates has made every effort to provide a complete line of equipment for unattended operation. It is recognized that unusual situations may demand special accessories. Gates engineers will happily work with our customers on any special application.



# DUMMY ANTENNAS



## AIR COOLED 10KW DUMMY ANTENNA

Designed for testing 10KW broadcast transmitters. Usable between 200 Kc and 6 Mc. Includes series of wire-wound resistance elements. Power rating based on 100% modulation at 10KW. Fully housed as illustrated. Size 27 1/2" x 26" x 16 3/8" high.

Dummy Antenna, 10KW ..... M-6107



## AIR COOLED 5KW DUMMY ANTENNA

Though designed primarily as a dummy antenna for testing 5KW broadcast transmitters, this unit may be used between 200 Kc and 6 Mc with excellent results. Includes series of wire-wound resistance elements. Power rating based on 100% modulation at 5KW. Fully housed as illustrated. Size: 27 1/2" x 26" x 10 1/4" high.

Dummy Antenna, 51 ohms ..... DU-151  
 Dummy Antenna, 70 ohms ..... DU-570



## AIR COOLED 1KW DUMMY ANTENNA

This unit may be used for any transmitter between 200 Kc and 6 Mc at a maximum power rating of 1KW, 100% modulated. Consists of non-inductive resistors heavily banded together to arrive at correct load resistance. Size 20 1/4" x 12 5/8" x 5" high.

Dummy Antenna, 51 ohms ..... DP-151  
 Dummy Antenna, 70 ohms ..... DU-170



## VHF 10-WATT DUMMY

Designed for measuring BFE-10B transmitter. Power rating 10 watts at 50-250 Mc. Has Type N connector for attaching RG-8U cable. Ideal for measuring low powered VHF transmitters including many types of police transmitters, etc. Impedance 50 ohms.

VHF Dummy Antenna ..... M-5645

## WATER COOLED DUMMY ANTENNAS

Available in 50KW design for broadcast and high frequency service. Ratings are at 100% amplitude modulation and 50% may be added where unmodulated. High frequency models are provided with variable coil and variable capacitor elements for tuning. Medium frequency models are straight resistance elements.

Paralleled wire resistance elements are precision supported in a water-tight glass enclosure around which filtered water is evenly distributed. Dual thermometers measure water temperature in and out and the differential is measured in power.



### SPECIFICATIONS

**WATER FLOW:**  
 (50KW) 15 gal. per min.

**LOAD RESISTANCE:**  
 Available in 50, 70, 150, 300 and 600 ohms, as ordered. High frequency models available 300 and 600 ohms only.

**SIZE:**  
 78" high, 42" wide, 48 1/2" deep.



### ORDERING INFORMATION

50KW model, 540-1600 Kc ..... M-5497      50KW model, 2-25 Mc ..... M-5497A  
 Above models built to order.

# TRANSFORMERS FOR BROADCASTING



These quality transformers for radio broadcasting, communications and television transmitters are regularly carried in stock and are of such specialized design they may not be found elsewhere. If you are modernizing, building your own or need a replacement transformer, you need not wait for it to be specially built as the Gates stock is in most cases immediately available.

## Transformers for 250 Watts

**MODULATION TRANSFORMER:** Primary for PP Class B, 810 tubes. Secondary 4000 ohms no current in Sec. Response 30-10,000 cycles  $\pm 1$  db. Fully cased.  $7\frac{1}{4}$ " high,  $6\frac{1}{8}$ " wide,  $5\frac{1}{4}$ " deep BM-1 MODULATION REACTOR: For use with modulation transformer BM-1 above. Inductance 65 hy. Current 250 MA  $\pm 1$  db, 30-10,000 cycle response. Fully cased. Size matches BM-1. BR-1

**DRIVER TRANSFORMER:** Primary PP 6L6, 1622, etc. Secondary Class B, 810 tube grids. Chassis mounting, fully cased. Response  $\pm 1$  db, 30-10,000 cycles. BD-1

**POWER TRANSFORMER:** Primary 215/230/245 volts, 50/60 cycles. Secondary 1700-0-1700 volts at .6 amperes continuous duty 3% regulation under Class B modulation. Case Style M. AP-7235

**SWINGING CHOKE:** 5-25 hy. at 500 MA. 52 ohms resistance. 7000V insulation. Round case, base terminals. CG-109

**SMOOTHING CHOKE:** 25 hy. at 300 MA. 90 ohms resistance. 5000V insulation. Round case, base terminals. CG-105

**DRIVER TRANSFORMER:** For PP 845 tubes or similar in Class A to PP 833A tubes Class B.  $\pm 1$  db, 30-10,000 cycles. Chassis mount. AS-3158C

**POWER TRANSFORMER:** Primary 230 volts, 50/60 cycles. Secondary 3100-0-3100 volts at 0.71 amperes to produce 2600 volts DC at 1 ampere when used with choke input filter. Case Style M. AP-10459E

**SWINGING CHOKE:** High inductance, high current type, 5-16 hy. at 1.5 amperes. Resistance 30 ohms. 10,000V insulation. Case Style M. AC-10458

**SMOOTHING CHOKE.**  $2\frac{1}{2}$  hy. at 700 MA. 20 ohms resistance. 10,000V insulation. Case Style O. AC-10457

## Transformers for 5000 Watts

**MODULATION TRANSFORMER:** Primary for PP Class B 3X2500A3 or 3X2500F3 tubes. Secondary 3600 ohms.  $\pm 1$ db, 30-10,000 cycles. Dry type. Case Style M. AM-7718E

**MODULATION TRANSFORMER:** Same specifications as AM-7718E above, only oil filled indoor or outdoor type in steel tank. Case Style N. AM-7718M

**MODULATION REACTOR:** 30 hy. at 1.4 amperes. Response  $\pm 1$  db, 30-10,000 cycles. Insulation 15,000V. Dry type. Case Style M. Companion to modulation transformer AM-7718E. AC-7719E

**MODULATION REACTOR:** Oil filled type in steel tank for indoor or outdoor mounting. 52 hy. at 1.4 amperes. Case Style N. Companion to modulation transformer AM-7718M. AC-7719M

**POWER TRANSFORMER:** Primary 205/215/230 volts, 50/60 cycles, 3 phase delta. Secondary 2160 volts per leg Y connected. Supplies 5000 volts DC at 2.3 amperes when used with six 8008 or 872A rectifier tubes. Dry type. Case Style M. Companion to AM-7718E and AC-7719E. AP-8000E

**POWER TRANSFORMER:** Primary 230 volts, 50/60 cycles, 3 phase delta. Secondary 2160 volts per leg Y connected to deliver 5000 volts DC at 2.3 amperes when used with six 8008 or 872A rectifiers. Oil filled type in steel tank for indoor or outdoor mounting. Case Style N. Companion to AM-7718M and AC-7719M. AP-8000M

**INPUT OR SMOOTHING CHOKE:** 4 hy. at 1.5 amperes. 17 ohms resistance. 8000V insulation RMS. Case Style M. AC-3143A

**DRIVER TRANSFORMER:** For PP parallel 845 tubes or similar Class A to PP 3X2500A3 or 3X2500F3 grids Class B.  $\pm 1$  db, 30-10,000 cycles. Chassis mount. Balance windings for individual biasing of 3X2500 grids. AS-3172C

## Transformers for 1000 Watts

**MODULATION TRANSFORMER:** Primary for PP 833A in Class B. Secondary 4750 ohms no current in Sec. Also has a second tapped secondary to provide 2, 4 or 8 watts for modulating the RF driver stage, if desired.  $\pm 1$  db, 30-10,000 cycles. Case Style M. AM-30469E

**MODULATION REACTOR:** For use with AM30469 modulation transformer. Inductance 32 hy. Resistance 240 ohms. Current 600 MA. Response  $\pm 1$  db. 30-10,000 cycles. Case Style M. A-38331K

## Transformers for 10,000 Watts

**MODULATION TRANSFORMER:** Dry Type, Style M Case. For PP 3X2500 F3 tubes. AM-30643E

**MODULATION TRANSFORMER:** Same as above except oil filled, Type N Case. AM-32886E



## TRANSFORMERS FOR BROADCASTING

### TRANSFORMERS (continued)

MODULATION REACTOR: Dry Type, Style M Case. 36 hy. at 3.8 amps. AC-3168E

MODULATION REACTOR: Same as above except oil filled, Type N Case. AC-32887E

DRIVER TRANSFORMER: For PP parallel 845 tubes or similar Class A to PP 3X2500A3 or 3X2500F3 grids Class B.  $\pm 1$  db, 30-10,000 cycles. Chassis mount. Balanced windings for individual bias of 3X2500 tubes. AS-3172C

POWER TRANSFORMER: Primary 230 volts, 50/60 cycles, 3 phase delta. Secondary tapped to deliver 5000, 5250 or 5500 volts DC at 4.5 amperes when used with six 673 tubes Y connected. Dry type. Case Style P. AP-3090E

POWER TRANSFORMER: Same as above, only oil filled in steel tank for indoor and outdoor mounting. Case Style N. AP-11111M

INPUT OR SMOOTHING CHOKER: 2 hy. at 3 amperes. 6.4 ohms resistance. 18,000 volt insulation. Case Style M. in 10KW broadcast, 2 chokes are used as input chokes for RF and modulators. AC-3147E

### Transformers for 20KW

MODULATION TRANSFORMER: Primary for four 3X3000A1 or 3X3000F1 tubes in PP parallel, impedance 5000 ohms plate to plate. Secondary 935 ohms to match Class C amplifier of four 3X2500A3 or 3X2500F3 tubes.  $\pm 1$  db, 30-10,000 cycles. Oil filled indoor and outdoor type. Case Style N. Use with modulation reactor AC-8675M and driver transformer AS-8672E listed below. AM-8674M

MODULATION REACTOR: 14 hy. at 5.25 amperes.  $\pm 1$  db, 30-10,000 cycles. Oil filled indoor or outdoor type. Case Style N. Use with AM-8674M modulation transformer and 8 mfd. coupling capacitor. AC-8675M

DRIVER TRANSFORMER: Primary two 845 tubes or similar in Class A. Secondary two windings for Class B grids of four 3X3000A1 or 3X3000F1 tubes in PP parallel.  $\pm 1$  db, 30-10,000 cycles. Chassis mount. AS-8672C

POWER TRANSFORMER: Suggest separate power supplies for modulators and RF, using two Type AP-11111M power transformers as listed above under 10KW transformers.

FILTER REACTOR: 2 hy. at 5.3 amperes. Oil filled indoor or outdoor mounting. For 20KW two used for dual power supplies as suggested above under "Power Transformer." Case Style N. AC-8673M

### Transformers for 50KW

MODULATION TRANSFORMER: Primary 3300 ohms plate to plate for two 5891 tubes, Class B, with 10.7 KV on plates. Secondary 1700 ohms. Oil filled in steel tank for indoor or outdoor service.  $\pm 2$  db, 30-10,000 cycles. Case Style N. Size: 33" wide, 42" deep, 58" high. AM-11788

MODULATION REACTOR: For use with AM-11788 above. 25 hy. at 6.5 amperes. 7600 volts RAS at 30 cycles.  $\pm 2$  db, 30-10,000 cycles. Oil filled in steel case for indoor or outdoor mounting. Size: 40" diameter, 56" high. Case Style N. AC-11787

POWER TRANSFORMER: Primary 460 volts single phase, 50/60 cycles. 3 required for 3 phase delta primary and secondary. Primary has 2 1/2% taps above and below 460V. Secondary 8300-4150 volts. When used with 3 phase full wave bridge rectifier, filter reactor AC-11786 below and six type 857B rectifier tube will deliver 10,700 volts DC at 13 amperes. Case Style N. Oil filled indoor or outdoor mounting. Size: 27" diameter, 56" high. AP-11785M

FILTER REACTOR: 1 hy. at 13 amperes, 34,000 volt test insulation. Oil filled in steel tank for indoor or outdoor mounting. Case Style N. AC-11786

### Filament Transformers

FOR SINGLE 3X2500A3 or 3X2500F3. Primary 215/230/245 volts, 50/60 cycles. Secondary 7.8 VCT 51 ampere. Case Style R. AF-7782E

FOR THREE 3X2500A3 or 3X2500F3. Primary 215/230/245 volts, 50/60 cycles. Three separate 7.8 VCT 51 ampere secondaries. Case Style R. AF-10434E

FOR 5891 TUBE IN 50KW SERVICE. Three required for 3 phase. Primary 230 volts, single phase, 50/60 cycles with  $\pm 2 1/2\%$  taps. Secondary 11 volts at 95 amperes. Primaries are delta connected and secondaries Y connected. Size 6 1/4" wide, 9 3/8" high, 7 7/8" deep. AF-11856E

FOR FOUR 833A OR SIMILAR TUBES. Primary 230 volts, 50/60 cycles. Secondary No. 1, 10 VCT at 10 amperes. Secondary No. 2, 10 VCT at 10 amperes. Secondary No. 3, 10 VCT at 20 amperes. Has heavy wire leads for direct connection to tube sockets. Case Style R. AF-30099E

RECTIFIER FILAMENT TRANSFORMER. Has 6 secondary windings 5 VCT at 10 amperes for 8008, 872A or 673 rectifier tubes. Primary 215/230/245 volts single phase, 50/60 cycles. Used as rectifier filament transformer in 5, 10 and 20 KW transmitters. Insulation 15,000 volts. Case Style R. AF-10432E

RECTIFIER FILAMENT TRANSFORMER. Primary 230 volts, 50/60 cycles. Secondary 5-1 VCT at 15 amperes for two 8008 or 872A rectifier tubes. Insulation 10,000 volts. AF-10456K

RECTIFIER FILAMENT TRANSFORMER. For 857R rectifier filament as used in 50KW service. Primary 230 volts, 50/60 cycles with  $\pm 2 1/2\%$  taps. Secondary 5 volts at 33 amperes. Insulation all points 25,000 volts. Size: 6" wide, 3 7/8" deep, 8" high. AF-11857E

### Audio Transformers

INPUT TRANSFORMERS: For transmitter input to low level audio stages. Handles +20 db input or less at low distortion. Quadruple shielding. Round case chassis mount.  $\pm 1$  db, 30-15,000 cycles. Primary 125/250 or 500/600 ohms. Secondary for PP or single grid 120,000 ohms. AI-3002U

INPUT TRANSFORMER: Specifically designed for high quality preamplifier input. Triple shielding. Round case. Primary 50/150/250 ohms. Secondary to single 60,000 ohm grid. 1 3/4" diameter and 1 5/16" high. Maximum input level 0 db,  $\pm 1/2$  db, 30-15,000 Cycles. AI-10379T

INPUT TRANSFORMER: Identical to AI-10379T above, only primary 600/150 ohms. AI-10386T

OUTPUT TRANSFORMER: Preamplifier output transformer to match AI-10379T or AI-10386T input transformers. Primary 15,000 ohms, no DC in winding. Secondary 150/250 and 600 ohms. Excellent shielding. Size: 1" diameter and 1 3/16" high.  $\pm 1/2$  db, 30-15,000 cycles. AO-10427T

OUTPUT TRANSFORMER: For program or remote amplifiers. Primary 10,000 ohms with up to 15 MA in winding. Secondary 150/250 and 600 ohms. Excellent shielding. Size: 2" wide, 1 3/4" deep, 2 3/4" high.  $\pm 1$  db, 30-15,000 cycles. AO-10864T

REPEATER TRANSFORMER: Line to line. Primary and secondary 50/125/250/500 and 600 ohms. Maximum level +16 db. Response 20-20,000 cycles  $\pm 1$  db. Fully cased top or chassis mounting. 114A

### 50,000 TRANSFORMERS

Listed on these pages is only a fraction of the huge transformer stock in the Gates stock rooms. If you have a breakdown, call the Gates service department first. If you need a special, it is likely Gates will have it. From the smallest ounce weight unit to 50 KW, be it audio, filter, power, equalizer, autotransformer or filament transformers, the 50,000 transformer stock is the largest in the world geared to broadcaster and communications needs.

# INDUCTORS, VARIABLE AND FIXED



A



B

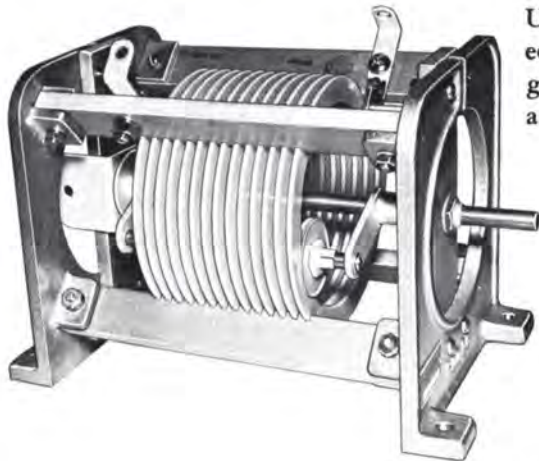

Used in both Gates and many other makes of transmitters and phasing equipment. Variable coils have cast aluminum end bells with double gripping bearing wheels. All types are micalex insulated and silver plated and have the highest possible "Q's".

## LEGEND:

- FA — Fixed 1/4" edgewise, 10 amp. rating, Fig. A.
- FB — Fixed 3/8" edgewise, 15 amp. rating, Fig. A.
- FC — Fixed 1/2" edgewise, 20 amp. rating, Fig. A.
- FBT — Fixed 3/8" copper tubing, 30 amp. rating, Fig. B.
- FCT — Fixed 1/2" copper tubing, 40 amp. rating, Fig. B.
- VB — Variable 3/8" edgewise, 15 amp. rating, Fig. C.
- VC — Variable 1/2" edgewise, 20 amp. rating, Fig. C.

Ind. uh	Length	Diam.	Cat. No.	Ind. uh	Length	Diam.	Cat. No.
87	12 1/16"	4"	87FA4634	67	13 1/16"	6"	67FC2856
6	6 1/4"	4"	6FC0854	78	16"	8"	78FC2568
10	6 1/4"	5"	10FC0855	10	12 1/2"	6"	10FBT1066
13	6 1/4"	6"	13FC0856	32	15"	8"	32FBT-1658
17	8 3/4"	4"	17FC1654	45	18 1/2"	8"	45FBT2158
24	8 3/4"	5"	24FC1655	65	24 1/2"	9"	65FBT2559
32	8 3/4"	6"	32FC1656	17	14"	8"	17FCT1178
42	12 5/8"	6"	42FC2266	35	24 1/2"	9"	35FCT1779



D

## VARIABLE COILS

Ind. uh	Length	Diam.	Cat. No.	Ind. uh	Length	Diam.	Cat. No.
6	8"	4"	6VC9854	16	9 1/8"	4"	16VB1544
15	10 3/4"	4"	15VC1444	30	11 1/8"	4"	30VB2344
26	10 3/4"	4"	26VC2144	105	12 1/2"	5"	105VB3735

## CLIPS

- LC4 For 1/4" edgewise FA coils
- LC6 For 3/8" edgewise FB coils
- LC8 For 1/2" edgewise FC coils
- RC6 For 3/8" tubing FBT coils
- RC8 For 1/2" tubing FCT coils

## DIAL FOR VARIABLE COIL

- M-5521 Veeder counter geared type, reads to 1/10" turn. 3/8" diam. shaft.

Fig. D

- M-3401F Same as M-5221 except 1/4" diam. shaft.

# MICA AND FILTER CAPACITORS



## TYPE F

Catalog Number	Capacity Mfd.	Peak Wkg. Volts
<b>Type G1</b>		
G1-641	.00001	6000
G1-645	.00005	6000
G1-631	.0001	6000
G1-632	.0002	6000
G1-634	.0004	6000
G1-635	.0005	6000
G1-621	.001	6000
G1-6215	.0015	6000
G1-622	.002	6000
G1-623	.003	6000
G1-624	.004	6000
G1-625	.005	6000
G1-526	.006	5000
G1-511	.01	5000
G1-4115	.015	4000
G1-312	.02	3000

Catalog Number	Capacity Mfd.	Peak Wkg. Volts
<b>Type G4</b>		
G4-3031	.0001	30000
G4-30315	.00015	30000
G4-30325	.00025	30000
G4-3035	.0005	30000
G4-3038	.0008	30000
G4-3021	.001	30000
G4-25215	.0015	25000
G4-2022	.002	20000
G4-2023	.003	20000
G4-2024	.004	20000
G4-1525	.005	15000
G4-1526	.006	15000
G4-1228	.008	12000
G4-1011	.01	10000
G4-612	.02	6000
G4-514	.04	5000

Catalog Number	Capacity Mfd.	Peak Wkg. Volts
F2-533	.0003	5000
F2-534	.0004	5000
F2-535	.0005	5000
F2-536	.0006	5000
F2-5375	.00075	5000
F2-538	.0008	5000
F2-521	.001	5000
F2-5215	.0015	5000
F2-522	.002	5000
F2-5225	.0025	5000
F2-523	.003	5000
F2-424	.004	4000
F2-325	.005	3000
F2-326	.006	3000
F2-328	.008	3000
F2-211	.01	2000
F2-2115	.015	2000
F2-212	.02	2000
F2-213	.03	2000
F2-1514	.04	1500
F2-1515	.05	1500
F2-0501	.1	500
F2-0202	.2	250
F2-02025	.25	250

Type	Capacity
7106-2	2— 600 volts DC
7106-4	4— 600 volts DC
7106-8	8— 600 volts DC
7106-10	10— 600 volts DC
7110-2	2—1000 volts DC
7110-4	4—1000 volts DC
7110-8	8—1000 volts DC
7110-10	10—1000 volts DC
7120-2	2—2000 volts DC
7120-4	4—2000 volts DC
7120-8	8—2000 volts DC
7120-10	10—2000 volts DC
7130-2	2—3000 volts DC
7130-4	4—3000 volts DC
7130-8	8—3000 volts DC
7140-2	2—4000 volts DC
7140-4	4—4000 volts DC
7140-6	6—4000 volts DC
7150-2	2—5000 volts DC
7150-4	4—5000 volts DC
7160-1	1—6000 volts DC
7160-2	2—6000 volts DC
7175-1	1—7000 volts DC
7175-2	2—7000 volts DC
TK70040	4—7000 volts DC

Catalog Number	Capacity Mfd.	Peak Wkg. Volts
<b>Type G2</b>		
G2-10325	.00025	10000
G2-1035	.0005	10000
G2-1021	.001	10000
G2-10212	.0012	10000
G2-10215	.0015	10000
G2-1022	.002	10000
G2-823	.003	8000
G2-824	.004	8000
G2-525	.005	5000
G2-526	.006	5000
G2-511	.01	5000
G2-4115	.015	4000
G2-312	.02	3000

Catalog Number	Capacity Mfd.	Peak Wkg. Volts
<b>Type F1 Mica Capacitors</b>		
F1-341	.00001	3000
F1-345	.00005	3000
F1-331	.0001	3000
F1-3315	.00015	3000
F1-332	.0002	3000
F1-3325	.00025	3000
F1-333	.0003	3000
F1-334	.0004	3000
F1-335	.0005	3000
F1-336	.0006	3000
F1-3375	.00075	3000
F1-338	.0008	3000
F1-321	.001	3000
F1-3215	.0015	3000
F1-322	.002	3000
F1-3225	.0025	3000
F1-223	.003	3000
F1-224	.004	2000
F1-225	.005	2000
F1-226	.006	2000
F1-1528	.008	1500
F1-111	.01	1000
F1-112	.02	1000
F1-10215	.05	250
F1-0201	.1	250

Catalog Number	Capacity Mfd.	Peak Wkg. Volts
<b>Type F3 Mica Capacitors</b>		
F3-8325	.00025	8000
F3-835	.0005	8000
F3-821	.001	8000
F3-822	.002	8000
F3-825	.005	8000
F3-811	.01	8000
F3-415	.05	4000
F3-201	.1	2000
F3-06025	.25	600
F3-0605	.5	600
F3-0610	1.0	600

Catalog Number	Capacity Mfd.	Peak Wkg. Volts
<b>Type G3</b>		
G3-2031	.0001	20000
G3-2032	.0002	20000
G3-20325	.00025	20000
G3-2033	.0003	20000
G3-2035	.0005	20000
G3-2038	.0008	20000
G3-2021	.001	20000
G3-15215	.0015	15000
G3-1522	.002	15000
G3-1523	.003	15000
G3-1524	.004	15000
G3-1025	.005	10000
G3-1026	.006	10000
G3-1028	.008	10000
G3-1011	.01	10000
G3-512	.02	5000
G3-313	.03	3000

Catalog Number	Capacity Mfd.	Peak Wkg. Volts
<b>Type F2 Mica Capacitors</b>		
F2-545	.00005	5000
F2-531	.0001	5000
F2-5315	.00015	5000
F2-532	.0002	5000
F2-5325	.00025	5000

## Type E

Catalog Number	Capacity Mfd.	Test Volts D.C.
E-1245	.00005	12500
E-1231	.0001	12500
E-12325	.00025	12500
E-1235	.0005	12500
E-1221	.001	12500
E-12215	.0015	12500
E-1222	.002	12500
E-1023	.003	10000
E-1024	.004	10000
E-1025	.005	10000
E-721	.001	7000
E-722	.002	7000
E-723	.003	7000
E-711	.01	7000
E-3524	.004	3500
E-3525	.005	3500
E-3511	.01	3500
E-3512	.02	3500
E-3515	.05	3500
E-215	.05	2000
E-201	.1	2000



TYPE E



TYPE H  
MICA CAPACITORS

## 1200 W.V.D.C.

Type	Capacity
H-T2450	.00005
H-T2310	.0001
H-T2320	.0002
H-T2325	.00025
H-T2330	.0003
H-T2340	.0004
H-T2350	.0005
H-T2210	.001
H-T2215	.0015
H-T2220	.002
H-T2225	.0025
H-T2230	.003
H-K2240	.004
H-K2250	.005
H-K2260	.006
H-K2280	.008
H-K2110	.01



# OPEN WIRE TRANSMISSION LINE

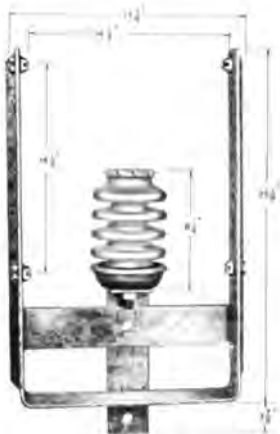

M-3327 Bracket

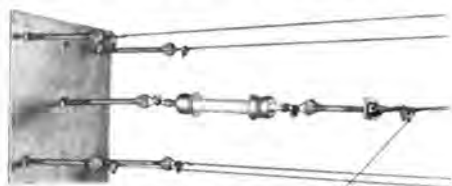

M-3328 End Plate



M-2870D Feed-Thru Bowl



M-3322 Horn Gap



M-3864 Center Post

## Transmission Line Bracket

For 5 or 6 wire transmission line. Rating up to 150KW modulated. Made of 1/4" steel 3" wide with welded L section on each side to fully prevent twisting under ice or wind load. Supplied with 8 1/4" ribbed insulator, wire guides and all hardware. Galvanized throughout.

Line Bracket ..... M-3327

## Line End Plate

To terminate the open wire line at each end. Plate is 1/4" thick, 20" square. Fully galvanized. Includes turnbuckles, 25 1/2" strain insulator and all hardware. Rating up to 150 KW modulated.

End Plate ..... M-3328

## Feed-Thru Bowls

A large feed-thru bowl with 50KW modulated rating. Available in single and double units and with solid or hollow studs as listed below. Bowls are Alsimag. Hardware heavy brass. Velutex seals are provided for weather-tight installation.

Solid stud, 2 bowls, for walls to 10 1/2" thick ..... M-2870D  
 Same as above but hollow stud ..... M-3254  
 Solid stud, single bowl, for walls 1" thick ..... M-5280  
 Same as above but hollow stud ..... M-5281

## Horn Gap

A very desirable item where higher power is employed. Connects to hot side of line and ground to drain off lightning and heavy static discharges. Usually one is employed for each 200' of line. Insulator for 150KW arc gaps heavy chrome plate. Galvanized throughout.

Horn Gap ..... M-3322

## Center Post Assembly

Has variety of uses such as end or corner angling of transmission line, support insulator for two wire line or rhombic antennas, and a guide insulator such as end of building or coupling unit. Rating 150KW galvanized throughout.

Center Post Insulator ..... M-3864

## Hard Drawn Wire

If desired, when ordering transmission line components, Gates will gladly supply No. 6, 8 or 10 hard drawn copper wire of current market prices. State length in feet desired, remembering to multiply the length of line by the number of wires in line, either 5 or 6.

## Special Open Wire Lines

Gates engineers have designed many special open wire lines for both short and long distances. Most celebrated was a 30-mile line supplies for use in the Arctic Circle. Upon receipt of a sketch or word description of the requirements, Gates engineers will gladly submit layout and quotation.

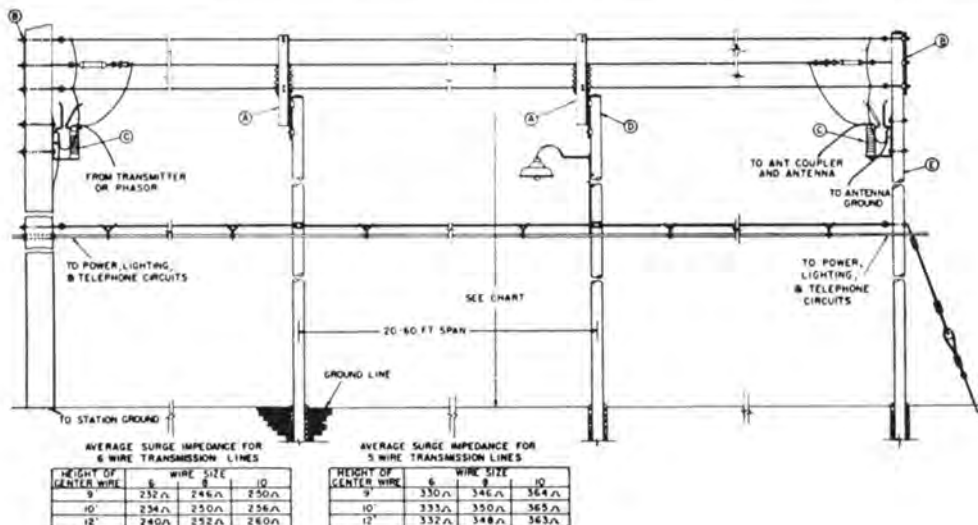

## Open Wire Design and Impedance Chart

Chart to the left illustrates typical five or six wire open type transmission line. Table is provided to show impedances with various wire sizes at certain heights above ground. Transmission line brackets are M-3327, end plate M-3328. Horn gap is M-3322. The power, lighting and telephone circuits shown are optional, according to requirements of installation. Open wire line will average about the same per foot cost as 7/8" coaxial copper cable.

# COAXIAL CABLE, TOWER LIGHTS AND ACCESSORIES

## COAXIAL CABLE

Coaxial transmission line cable and fittings of nearly any description are available from Gates. Price and delivery information will gladly be furnished upon request.

## GROUND MATERIALS

- No. 10 SOFT DRAWN COPPER GROUND WIRE, packed in 100-pound coils, approximately 3100 feet in 100 pounds . . . . . GR-10
- COPPER GROUND STRAP 2" WIDE, packed in 100' rolls . . . . . GR-2ST
- COPPER GROUND STRAP 4" WIDE, packed in 50' rolls . . . . . GR-4ST
- GROUND-ROD, Copperweld heavy ground rod 8' long . . . . . GR-8R
- GROUND SCREEN, heavy copper, 3/4" mesh in sheets 8' x 24' . . . . . GR-24SC

The above materials are carried in Quincy. Prices shown in price list vary with copper market.

## TOWER LIGHTS

- SINGLE OBSTRUCTION LIGHT, bottom entrance conduit fitting furnished with lamp receptacle to accommodate either a 100 or 111 watt, 115V medium screw base lamp, or lumen medium pre-focus series lamp . . . . . OB-20
- SINGLE OBSTRUCTION LIGHT, same as Model OB-20 above but side entrance conduit fitting . . . . . OB-21
- DOUBLE OBSTRUCTION LIGHT, provided with two lamp receptacles, each accommodating either 100 or 111 watts, medium screw base lamp, or lumen medium pre-focus lamp. Bottom entrance fitting type for 1" conduit.
  - FOR MEDIUM SCREW BASE . . . . . OB-22-4
  - FOR PRE-FOCUS BASE . . . . . OB-22P-4
- CODE BEACON 300 MM, standard fully approved model supplied with two red filters.
  - FOR 3/4" CONDUIT . . . . . KG-114-3
  - FOR 1" CONDUIT . . . . . KG-114-1
- REPLACEMENT LAMP, 100 WATT OBSTRUCTION . . . . . 100A21-TS

- REPLACEMENT LAMP, 111 WATT OBSTRUCTION . . . . . 111A21-TS
- BEACON LAMP, 500 WATT . . . . . 500PS-40
- BEACON LAMP, 620 WATT . . . . . 620PS-40

## FLASHERS AND PHOTO CELL UNITS

- SINGLE UNIT, indoor housing, lighting control unit with outdoor remote weatherproof photo tube, includes complete flasher for flashing of three towers and photo-electric cell control for automatic turning on and off 115/230 V, 50/60 cycle, 3 conductors to each tower . . . . . LC-2077
- SINGLE UNIT, indoor housing, same as LC-2077 above but for 4 towers instead of 3 . . . . . LC-2076
- BEACON FLASHER, electro-mechanical device for outdoor mounting, meets FCC and CAA regulations, single pole mercury tilt switch and synchronous motor, Model BF-32 has fail-safe provision for 117 V, single circuit type.
  - BEACON FLASHER . . . . . BF-31
  - BEACON FLASHER with fail-safe . . . . . BF-32
- PHOTO-CELL AND BEACON FLASHER, a combination unit in weatherproof housing. Photo-cell may be rotated to north regardless of mounting position on tower. Turns on at 35-foot candles and off at 58-foot candles. Fully approved.
  - FOR 1 POLE 30 AMPERES, flashes 1 circuit . . . . . LC-2074
  - FOR 1 POLE 30 AMPERES, flashes 2 circuits . . . . . LC-2072

- FISCHER-PIERCE PHOTO-CELL UNIT, unit completely weatherproof, fully approved for turning on and off tower lights, has time delay of 5-7 seconds to prevent operating lights by chance exposure such as walking in front of unit.
  - PHOTO-CELL UNIT for 105-130 volts, 3000 watt rating, SPST, double break . . . . . 63305C
  - PHOTO-CELL UNIT, same as above but for 210-250 volts . . . . . 63306C

Gates is a national distributor for Andrew, Hughey & Phillips, Fisher-Pierce and other leading manufacturers of approved tower lighting equipment. Generous stocks are carried at the factory.



# THE EXECUTIVE

## Ten Channel Stereophonic Transistor Audio Control Console



The *Executive* 10-channel transistor console represents a vigorous program to design, develop and produce an audio system of extensive application to meet the critical needs of Stereo or Monaural AM, FM and TV dual channel broadcasting.

**MIXING SYSTEM:** Ten-channel stereo mixer utilizing low impedance ladder type controls in a parallel, minimum loss type, mixing circuit.

**MICROPHONE CHANNELS:** Three microphone channels can be individually switched from the front panel to either full stereo operation or fully isolated monophonic feed from one microphone into the stereo mixer. There are two separate preamplifiers in each of the three microphone channels, operated in parallel for stereo use. The second preamplifier is bridged off the first when a single microphone is used to feed the stereo program, simplifying disk jockey, control room or news room microphone insertions.

Microphone transfer switches are located immediately above the microphone mixing channels for instantaneous changes in programming requirements. A second switch for each microphone channel allows the selection of two sets of stereo microphones into each of the three channels. This permits the use of six sets of stereo microphones without patching.

**TURNTABLE CHANNELS:** Channels 4 and 5 have switching to accommodate four turntables into either channel in any sequence. A cue position on these two channels permits cueing in the channel not in use.

**TAPE CHANNELS:** Channels 6 and 7 have switching to accommodate four tape machines into either channel in any sequence. There is a cue position on channels 6 and 7 to permit previewing and cueing of all recorder material before feeding it to the transmitter.

**REMOTE CHANNEL:** Four remote lines are switched into channel 8 when mixed into either stereo or monophonic programming. The stereo mixer in channel 8 has a splitting

pad on the input to permit feeding a monophonic source to both sides of the stereo mixer.

**NETWORK CHANNEL:** Channel 9 is the network channel. It is also a stereo mixer with a splitting pad on the input, since most network facilities are monophonic at the present time. Should this condition change, you simply remove the splitting pad and the full stereo facilities are restored. An occasional stereo network program could be patched into one of the stereo channels. A cue position permits previewing the network, then smoothly fading it into the program channel.

**AUXILIARY CHANNEL:** Channel 10 is the auxiliary channel, with two isolation transformers on the input of the stereo mixer to prevent any interaction or grounding problems with almost any input source.

**CUE-INTERCOM SYSTEM:** The cue-intercom system provides flawless network monitoring, remote over-ride, remote talk-back, studio intercom, turntable cueing, tape cueing and general previewing and cueing of all but the microphone channels. The control room and studio speakers are muted by the channel keys and muting relays when there is a live microphone in any of these locations.

The cue signals from channels 4 through 10 are fed into the cue-intercom amplifier regardless of the position of the cue selector switch.

**PROGRAM SWITCHING FUNCTIONS:** One front panel switch changes the master operation of the *Executive* console from stereo to simultaneous or separate operation, as desired by the operator. Stereo program busses and stereo audition busses are designated: "Program Left," "Program Right," "Audition Left," and "Audition Right." The "Program Left" bus is permanently connected to the "Master Left" channel.

In the Stereo position, the input of the "Master Right" channel is connected directly to the "Program Right" bus. Thus, each half of the dual attenuators feed through a program amplifier to the stereo output line.



# THE EXECUTIVE

If the optional program amplifier is used during stereo programming, its input is bridged across the output of both the "Master Left" and "Master Right" channels. The output of the optional amplifier is then equal to L+R, the compatible stereo signal, and may be used to feed an AM transmitter.

In the Simultaneous position, the input of the "Master Right" channel is bridged off the output of the "Master Left" channel. This allows simultaneous programming of an AM and FM transmitter. If the optional program amplifier is used, its input can also bridge the output of the "Master Left" channel for simultaneous feed.

In the Separate position, the input of the "Master Right" channel for the optional program amplifier is connected to the "Audition Left" bus, so separate programming may be fed to the AM and FM transmitters.

The left hand VU meter is connected to the output of the "Master Left" channel at all times. This is the "Left"

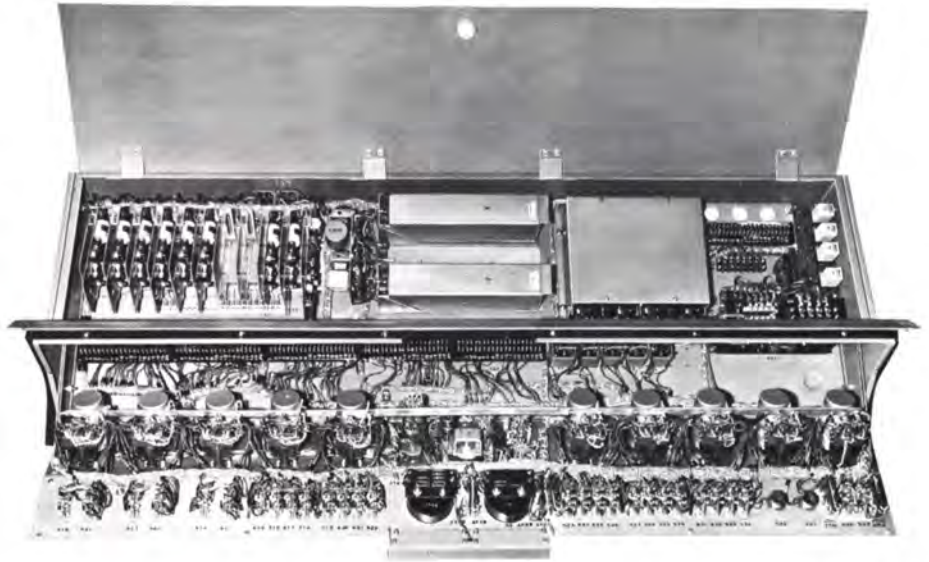

channel in stereo programming. The right hand meter can also be switched to the output of the "Master Left" channel for calibration check. It may also be switched to the output of the "Master Right" channel for stereo metering. In

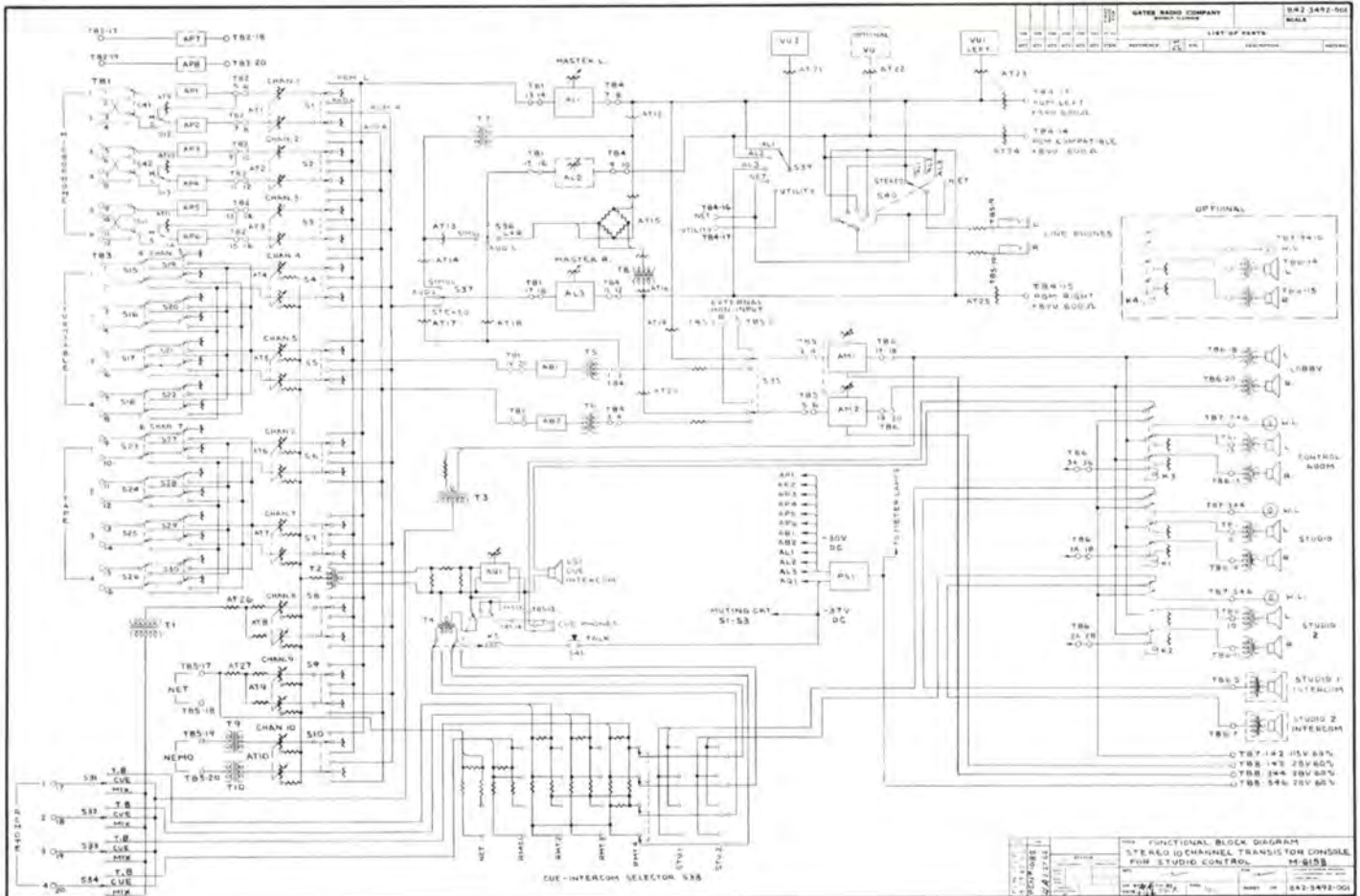

## THE EXECUTIVE

addition, it may be switched to the output of the optional program amplifier to check the level of the compatible stereo, or separate programming, to the AM transmitter. The next position on this switch connects the meter to the network feed to check the level of the network at any time. The last position is for external measurements.

**DUAL PHONE JACKS:** Stereo phone jacks are provided on a mounting plate and supplied with the *Executive* console. Mounting holes are provided in the plate to permit its installation on the front or top of the desk, or in any convenient place for the operator.

**STEREO MONITORING AMPLIFIERS:** Two 8 watt amplifiers are built in the *Executive* for complete stereo monitoring. An input switch on the stereo monitoring amplifiers permits them to be connected to the output of the master channels, the output of the audition bus booster amplifiers, or to an external stereo input. Two sets of muting contacts on each relay permits muting of the stereo speakers—in the control room and the studios. These relays are completely encased, and plug-in for complete reliability and maintenance.

**TRANSISTOR AMPLIFIERS:** The *Executive* stereo console is completely transistorized, incorporating Gates' exclusive Solid Statesman transistor amplifiers. These are absolutely the finest and most advanced transistor audio amplifiers in the entire broadcast industry. Each specification reveals a story of unparalleled performance and reliability.

All amplifiers are plug-in type, with the exception of the stereo monitor amplifiers. The standard amplifier complement consists of:

- 6 preamplifiers (3 pairs for stereo)
- 2 booster amplifiers (1 pair for stereo)
- 2 program amplifiers (1 pair for stereo)
- 2 monitor amplifiers (1 pair for stereo)
- 1 cue-intercom amplifier

In addition, there is the regulated transistorized power supply and provisions for a third compatible program amplifier.

**STYLING:** The styling concept of the *Executive* follows the distinctive symbol of Gates' exclusive Solid Statesman line. The satin anodized aluminum control panel "floats" in a three-dimensional setting—outlined and accented in a sweeping crescent of mar-resistant black. The free-floating front panel and "flip-top" lid are hinged to provide full accessibility to all internal components.

The large primary control knob, designed exclusively for Gates and used on all input channels, has a prominent raised pointer to allow precise setting of any channel without visual observation.  $2\frac{1}{4}$ " wide at the top and standing  $1\frac{5}{8}$ " from front to panel, the index is a blade extending from pointer to center hub. The pointer may be used as a tab to easily fade one or more channels simultaneously with a single finger per knob. The design of these new knobs follows the concept that program control is "feel control."

## EXECUTIVE SPECIFICATIONS

### MIXING CHANNELS:

- 10 Full stereophonic each with stereo low impedance ladder attenuator.

### INPUTS:

- 12 Stereo microphones to 6 preamps.
- 9 Stereo turntables, tape and projector inputs into 5 stereo mixers.
- 4 Remotes into 1 stereo mixer.
- 1 Individual stereo network channel.

### OUTPUTS:

- 3 Program lines:
  - 2 Stereo program lines—simultaneous or stereo.
  - 1 Monophonic compatible or independent program line.
- 8 Stereo muted monitor outputs.
- 2 Stereo unmuted monitor outputs.
- 4 Stereo recording outputs.
- 10 or more Stereo speaker outputs.
- 2 Interlocked studio intercom outputs.
- 2 Headphone outputs.

### AMPLIFIERS:

- 10 Plug-in transistor preamplifiers.
  - 6 Microphone preamplifiers.
  - 2 Optional microphone preamplifiers (where ordered).
  - 2 Booster amplifiers.
- 3 Plug-in transistor program amplifiers.
  - 2 Program amplifiers feeding stereo/simultaneous outputs.
  - 1 Optional compatible or independent.
- 1 Plug-in transistor cue/intercom amplifier.
- 2 Full level transistor monitor amplifiers with ganged level controls.

### POWER SUPPLY:

- 1 Fully regulated, electronically protected transistor power supply.

### GAIN:

- Microphone to program line: 102 db  $\pm$  3 db.
- Turntable/tape/projector/remote to program line: 55 db  $\pm$  2 db.
- Microphone to speaker output: 102 db  $\pm$  3 db.
- Turntable/tape/projector/remote to speaker output: 55 db  $\pm$  2 db.

## EXECUTIVE SPECIFICATIONS

## FREQUENCY RESPONSE:

- ±1.5 db from 20 to 20,000 cps in all regular program circuits. (Typical.)
- ±2.0 db from 20 to 20,000 cps in all monitor speaker circuits. (Typical.)
- ±1.0 db from 30 to 15,000 cps in all regular program circuits.
- ±1.5 db from 30 to 15,000 cps in all monitoring speaker circuits.

## HARMONIC DISTORTION:

- 0.5% Maximum, 20 to 20,000 cps at +8 dbm output in all regular program circuits. (Typical.)
- 1.0% Maximum, 20 to 20,000 cps at +38 dbm in all monitor speaker circuits. (Typical.)
- 0.5% maximum, 30 to 15,000 cps at +8 dbm output in all regular program circuits.
- 0.5% maximum, 50 to 15,000 cps at +18 dbm output in all regular program circuits.
- 1.0% maximum, 50 to 15,000 cps at +39 dbm (8 watts) in speaker outputs.

## INTERMODULATION DISTORTION:

- 0.5% Maximum in program circuits.
- 1.0% Maximum in monitor circuits.

## SOURCE IMPEDANCE:

- Microphones—30/50 or 150/250 ohms.
- Turntable/tape/projector/remote/network—600 ohms.

## LOAD IMPEDANCE:

- All program lines—600 ohms.
- Speaker outputs—4 to 16 ohms.
- Recording outputs—600 ohms.

## NOISE:

- 122 dbm relative input noise on microphone channels.
- 75 dbm relative input noise on medium level channels.

## CROSSTALK:

- Below noise level in all channels.

## STEREO ISOLATION:

- Below noise level in all channels.

## TRANSISTOR COMPLEMENT:

- 6 Industrial type totaling 76.

## POWER CONSUMPTION:

- Approximately 50 watts at 110/117/125 volts, 50/60 cps.

## SIZE:

- 53<sup>1</sup>/<sub>2</sub>" long, 11<sup>3</sup>/<sub>8</sub>" high and 17<sup>3</sup>/<sub>8</sub>" deep.

## WEIGHT:

- 107 lbs. net, 220 lbs. packed.

## CUBAGE:

- 26.6 cu. ft.

## FINISH:

- Satin anodized black nomenclature on natural anodized aluminum background panels on a medium gray cabinet.

## ORDERING INFORMATION

EXECUTIVE 10-channel transistor stereo audio control console, complete with 2 monitor amplifiers, 6 preamplifiers, 2 booster amplifiers, cue-intercom amplifier, 2 program amplifiers and power supply

Extra preamplifier

Intercom sub-station

M-6158

M-6034

M-5303

# THE DIPLOMAT

## Ten Channel Monophonic Transistor Audio Control Console



The Diplomat 10 channel console is a dual channel monaural version of the Executive stereo console which is described on previous pages. It provides all of the audio system facilities of the Executive with the exception of stereo. Where facilities are identical the reader is referred to the "Executive" Console copy.

**MIXING SYSTEM:** Ten-channel mixer utilizing low impedance ladder type controls in a parallel, minimum loss type, mixing circuit.

**MICROPHONE CHANNELS:** Three microphone channels can be individually switched from the front panel.

Microphone transfer switches are located immediately above the microphone mixing channels for instantaneous changes in programming requirements. A second switch for each microphone channel allows the selection of two sets of microphones into each of the three channels. This permits the use of six sets of microphones without patching.

**TURNTABLE CHANNELS:** See Executive copy.

**TAPE CHANNELS:** See Executive copy.

**REMOTE CHANNEL:** Four remote lines are switched into channel 8 when mixing for programming.

**NETWORK CHANNEL:** Channel 9 is the network channel. A cue position permits previewing the network, then smoothly fading it into the program channel.

**AUXILIARY CHANNEL:** Channel 10 is the auxiliary channel, with an isolation transformer on the input of the

mixer to prevent any interaction or grounding problems with almost any input source.

**CUE-INTERCOM SYSTEM:** See Executive copy.

**PROGRAM SWITCHING FUNCTIONS:** One front panel switch changes the master operation of the console from simultaneous to separate operation, as desired by the operator.

The optional program amplifier (AL2) may be used to provide simultaneous programming of an AM and FM transmitter, while using AL3 from the audition bus for recording. Either AL2 or AL3 may be used to bridge the output of AL1 for simulcasting or switched to the audition bus for separate programming.

The left hand VU meter is connected to the output of the #1 channel at all times. The right hand meter can also be switched to the output of the #1 channel for calibration check. It may also be switched to the output of the #2 channel for metering. In addition, it may be switched to the output of the optional program amplifier to check the level. The next position on this switch connects the meter to the network feed to check the level of the network at any time. The last position is for external measurements.

**PHONE JACKS:** Phone jacks are provided on a mounting plate and supplied with the Diplomat console. Mounting holes are provided in the plate to permit its installation on the front or top of the desk, or in any convenient place for the operator.

**MONITORING AMPLIFIER:** One 8 watt amplifier is built in the Diplomat for complete monitoring. An input

## THE DIPLOMAT

switch on the monitoring amplifier permits it to be connected to the output of the master channel, the output of the audition bus booster amplifier, or to an external input. Muting contacts on each relay permits muting of the speakers—in the control room and the studios. These relays are completely encased, and plug-in for complete reliability and maintenance.

**TRANSISTOR AMPLIFIERS:** The Diplomat stereo console is completely transistorized. All amplifiers are plug-in

type, with the exception of the monitor amplifier. The standard amplifier complement consists of:

- 3 preamplifiers
- 1 booster amplifier
- 2 program amplifiers
- 1 monitor amplifier
- 1 cue-intercom amplifier

In addition, there is the regulated transistorized power supply and provisions for a third compatible program amplifier. **STYLING:** See Executive copy.

## SPECIFICATIONS

### MIXING CHANNELS:

- 10 Channels each with low impedance ladder attenuator.

### INPUTS:

- 6 Microphones to 3 preamps.
- 9 Turntables, tape and projector inputs into 5 mixers.
- 4 Remotes into 1 mixer.
- 1 Individual network channel.

### OUTPUTS:

- 3 Program lines:
  - 2 Program lines.
  - 3 Independent program line.
- 4 Muted monitor outputs.
- 1 Unmuted monitor output.
- 2 Recording outputs
- 5 or more speaker outputs.
- 2 Interlocked studio intercom outputs.
- 2 Headphone outputs.

### AMPLIFIERS:

- 4 Plug-in transistor preamplifiers.
- 3 Microphone preamplifiers.
- 6 Optional microphone preamplifiers (where ordered).
- 1 Booster amplifier.
- 1 Optional Booster amplifier (where ordered).
- 3 Plug-in transistor program amplifiers.
- 2 Program amplifiers feeding dual channel outputs.
- 1 Optional program amplifier (where ordered).
- 1 Plug-in transistor cue/intercom amplifier.
- 1 Full level transistor monitor amplifier.

### POWER SUPPLY:

- 1 Fully regulated, electronically protected transistor power supply.

### GAIN:

- Microphone to program line: 102 db  $\pm$ 3 db.
- Turntable/tape/projector/remote to program line: 55 db  $\pm$ 2 db.

### FREQUENCY RESPONSE:

- $\pm$ 1.5 db from 20 to 20,000 cps in all regular program circuits. (Typical.)
- $\pm$ 2.0 db from 20 to 20,000 cps in all monitor speaker circuits. (Typical.)
- $\pm$ 1.0 db from 30 to 15,000 cps in all regular program circuits.
- $\pm$ 1.5 db from 30 to 15,000 cps in all monitoring speaker circuits.

### HARMONIC DISTORTION:

- 0.5% Maximum, 20 to 10,000 cps at +8 dbm output in all regular program circuits. (Typical.)
- 1.0% Maximum, 20 to 10,000 cps at +38 dbm in all monitor speaker circuits. (Typical.)
- 0.5% Maximum, 30 to 15,000 cps at +8 dbm output in all regular program circuits.
- 0.5% Maximum, 50 to 15,000 cps at +18 dbm output in all regular program circuits.
- 1.0% Maximum, 50 to 15,000 cps at +39 dbm (8 watts) in speaker outputs.

### INTERMODULATION DISTORTION:

- 0.5% Maximum in program circuits.
- 1.0% Maximum in monitor circuits.

### SOURCE IMPEDANCE:

- Microphones, 30/50 or 150/250 ohms.
- Turntable/tape/projector/remote/network, 600 ohms.

# THE DIPLOMAT

## SPECIFICATIONS—continued

### LOAD IMPEDANCE:

All program lines, 600 ohms.  
Speaker outputs, 4 to 16 ohms.  
Recording outputs, 600 ohms.

### NOISE:

—122 dbm relative input noise on microphone channels.  
—75 dbm relative input noise on medium level channels.

### CROSSTALK:

Below noise level in all channels.

### TRANSISTOR COMPLEMENT:

6 Industrial type totaling 52.

### POWER CONSUMPTION:

Approximately 34 watts at 110/117/125 volts, 50/60 cps.

### SIZE:

53 $\frac{1}{2}$ " long, 11 $\frac{3}{8}$ " high and 17 $\frac{3}{8}$ " deep.

### WEIGHT AND CUBAGE:

107 lbs. net, 220 lbs. packed. 26.6 cu. ft.

### FINISH:

Satin anodized black nomenclature on natural anodized aluminum background panels on a medium gray cabinet.

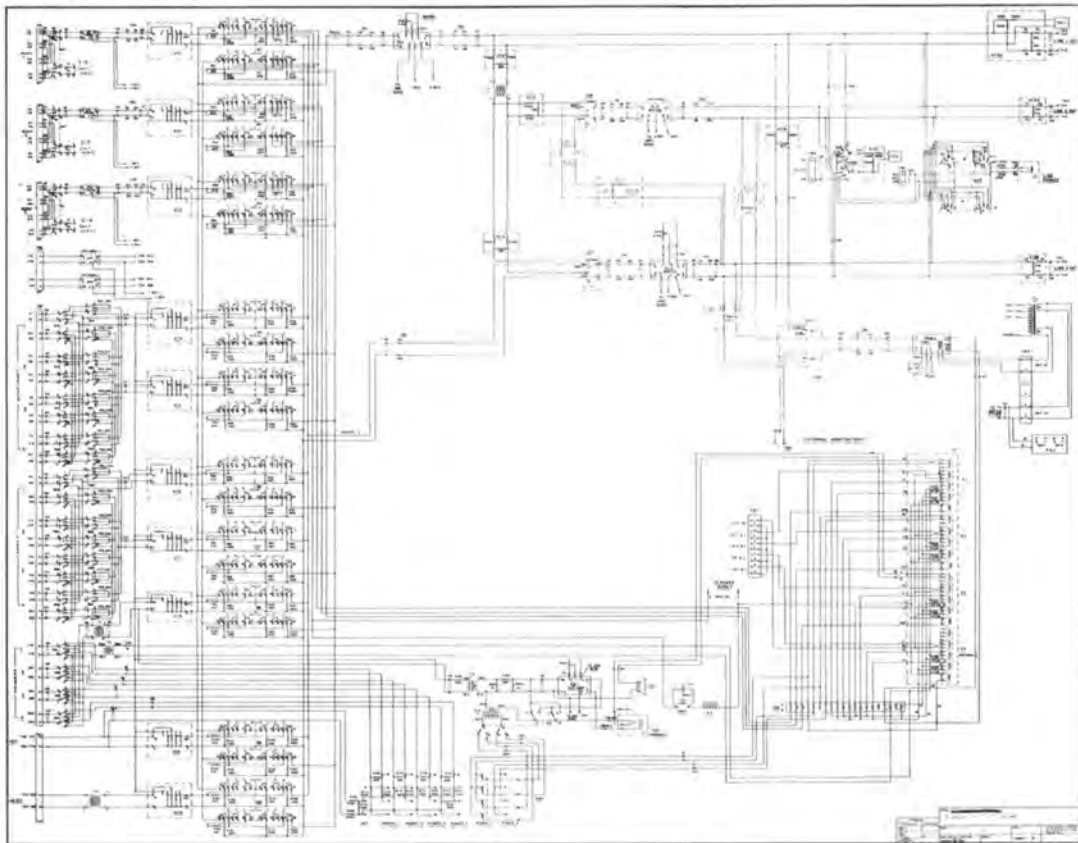

## ORDERING INFORMATION

Diplomat 10-channel transistor audio control console, complete with 1 monitor amplifier, 3 preamplifiers, 1 booster amplifier, cue-intercom amplifier, 2 program amplifiers and power supply .....	M-6377
Extra preamplifier .....	M-6034
Intercom sub-station .....	M-5303

# THE PRESIDENT

## Dual Channel Transistor Audio Control Console



The *President* is a completely transistorized dual channel audio control console, providing eight input mixing channels. It is distinctively designed with a totally new 12-position control center—activated by an array of 24 illuminated touch-control keys for precise fingertip command of input circuits. Twenty-eight inputs are provided in the *President*. When all six of the 3-position utility switches are used to expand the input facilities, a total of 45 inputs are available.

**MIXING SYSTEM:** Eight monophonic input mixing channels are provided utilizing low impedance, ladder type controls. Key selection allows any mixer to feed either program channel.

**MICROPHONE CHANNELS:** Eight microphones can be switched into four channels. Channels 1, 2, 6 and 7 each handle two microphones. Speaker muting is switched with mike selection. Channels 3 and 8 each provide two optional medium level or microphone level service by the addition of the optional plug-in microphone preamplifiers. If the preamplifiers are connected ahead of the input selector switch, the channels can fill the dual role of a microphone and medium level channel.

**MEDIUM LEVEL INPUTS:** Two multiple station, illuminated touch-control keys provide 12 positions and "off" as a control center for all medium level inputs. The upper bank feeds into channel four, the lower into channel five. When the input positions are not switched into either channel, they are automatically connected to the cue bus for preview or cueing. The twelve push-keys accommodate four remote lines plus the network into push-key number one and eleven medium level inputs into the remaining keys.

Gold program circuit contacts provide reliable maintenance-free "dry-contact" operation of the push-key switches. Silver alloy DC switching contacts illuminate the depressed station.

Isolation transformers are used generously in all of the critical circuits connected external to the "President."

**CUE-INTERCOM SYSTEM:** A fully interlocked cue-intercom system is incorporated in the *President*. The cue position of mixing channels 3 and 8, the network input

or any of the 12 push-button stations may feed the cue amplifier, regardless of the position of the cue amplifier input selector switch.

**MUTING RELAYS:** The speaker muting relays have extra intercom muting contacts to prevent feeding an intercom signal into the studios when a live microphone is in use. The control room muting relay is factory wired to mute the console speaker for any type of signal when the control room microphone is in use. A cue phone jack permits headphone monitoring of the cue-intercom circuits during these periods.

**TRANSISTOR AMPLIFIERS:** The *President* is completely transistorized, incorporating Gates exclusive Solid Statesman transistor amplifiers. The standard amplifier complement consists of:

- 4 Plug-in transistor microphone preamplifiers
- 2 Optional additional transistor preamplifiers
- 2 Plug-in transistor program amplifiers
- 1 Plug-in transistor cue-intercom amplifier
- 1 Full level transistor monitoring amplifier
- 1 Fully regulated transistor power supply

The 10 db overload capacity of the program amplifiers, coupled with at least 20 db overload capacity in the microphone preamplifiers, make the *President* almost impervious to excessive program levels. The full 6 db line isolation pad permits the connection of this console to highly reactive telephone lines without any noticeable interaction.

The +39 dbm (8 watt) capability of the transistor monitor amplifier is combined with flat response, low harmonic and intermodulation distortion that is almost beyond belief.

The regulated power supply protects the console amplifiers from variations due to line and load regulation. In addition, the power supply ripple is reduced to the point of nonexistence to assure uniformly low noise in all of the console circuits. The power supply is also short-circuit protected to prevent damage to any of the transistors in either the power supply or amplifiers from a momentary or sustained short in any of the circuits.

## THE PRESIDENT

**STYLING:** The styling concept of the *President* follows the distinctive symbol of Gates' exclusive Solid Statesman line. The free-floating front panel and "flip-top" lid are hinged to provide full accessibility to all internal components.

The large primary control knob, designed exclusively for Gates and used on all input channels, has a prominent raised pointer to allow precise setting of any channel without visual observation.

Multi-position illuminated VU meters are provided with the *President*. They may mount anywhere along the top rail of the console, or with the mounting clip removed, be placed on the console desk. The meters are

**M-6115 TRANSISTOR CONSOLE:** An additional low-level unit may be purchased for use with the three standard sections of the *President*. This will facilitate multiple console installations offering unlimited control functions.



mounted in sturdy cast aluminum housings with interconnecting cables and plugs.

The low-level section—as a separate unit—is referred to as the M-6115 sub-master console. It may be used in large studios to mix three channels (or six microphones) with one feed into the master control. It is also ideally suited for custom recording use, where from one to three units (3 to 9 channels) may be used together without internal modifications, and for sub-mixing channel applications in TV.

## PRESIDENT SPECIFICATIONS

### MIXING CHANNELS:

8 Monophonic.

### INPUTS:

- 12 Microphones into 6 preamplifiers.
- 11 Turntables, tape and projector inputs into 2 mixers.
- 4 remote lines.
- 1 Network.

### OUTPUTS:

- 2 Program lines.
- 3 Muted speaker outputs.
- 1 Unmuted speaker output.
- 2 Interlocked studio intercom speakers.
- 2 Headphone outputs.

### AMPLIFIERS:

- 6 Plug-in transistor preamplifiers.
- 4 Microphone preamplifiers.
- 2 Optional microphone preamplifiers (where ordered).
- 2 Plug-in transistor program amplifiers.
- 1 Plug-in transistor cue-intercom amplifier.
- 1 Full level transistor monitor amplifier.

### POWER SUPPLY:

- 1 Fully regulated, electronically protected transistor power supply.

### GAIN:

- Microphone input to line output: 104 db  $\pm$  3 db.
- Turntable input to line output: 56 db  $\pm$  2 db.
- Microphone input to speaker output: 104 db  $\pm$  3 db.
- Turntable input to speaker output: 56 db  $\pm$  2 db.

### FREQUENCY RESPONSE:

- $\pm$ 1.5 db from 20 to 20,000 cps in all regular program circuits (typical).
- $\pm$ 2.0 db from 20 to 20,000 cps in all monitor speaker circuits (typical).
- $\pm$ 1.0 db from 30 to 15,000 cps in all regular program circuits.
- $\pm$ 1.5 db from 30 to 15,000 cps in all monitoring speaker circuits.

### HARMONIC DISTORTION:

- 0.5% Maximum, 20 to 20,000 cps at +8 dbm in all regular program circuits (typical).
- 1.0% Maximum, 20 to 20,000 cps at +38 dbm in all monitor speaker circuits (typical).
- 0.5% Maximum, 30 to 15,000 cps at +8 dbm output in all regular program circuits.
- 0.5% Maximum, 50 to 15,000 cps at +18 dbm output in all regular program circuits.
- 1.0% Maximum, 50 to 15,000 cps at +39 dbm (8 watts) in speaker outputs.



**PRESIDENT SPECIFICATIONS**

**INTERMODULATION DISTORTION:**

0.5% Maximum in program circuits.  
1.0% Maximum in monitor circuits.

**SOURCE IMPEDANCE:**

Microphones—30/50 or 150/250 ohms.  
Turntable/tape/projector/remote/network—600 ohms.

**LOAD IMPEDANCE:**

2 Program lines—600 ohms.  
Speaker outputs—4 to 16 ohms.  
Recording output—600 ohms.

**NOISE:**

—122 dbm relative input noise on microphone channels.  
—75 dbm relative input noise on medium level channels.

**CROSSTALK:**

Below noise level in all channels.

**TRANSISTOR COMPLEMENT:**

6 Industrial type totaling 56.

**POWER CONSUMPTION:**

Approximately 44 watts at 110/117/125 volts, 50/60 cycles.

**SIZE:**

52<sup>3</sup>/<sub>8</sub>" long, 11<sup>3</sup>/<sub>8</sub>" high, 17<sup>3</sup>/<sub>8</sub>" deep.

**WEIGHT:**

114 lbs. net. 220 lbs. packed.

**CUBAGE:**

26.6 cu. ft.

**FINISH:**

Satin anodized black nomenclature on natural anodized aluminum background panels, on medium gray cabinet.

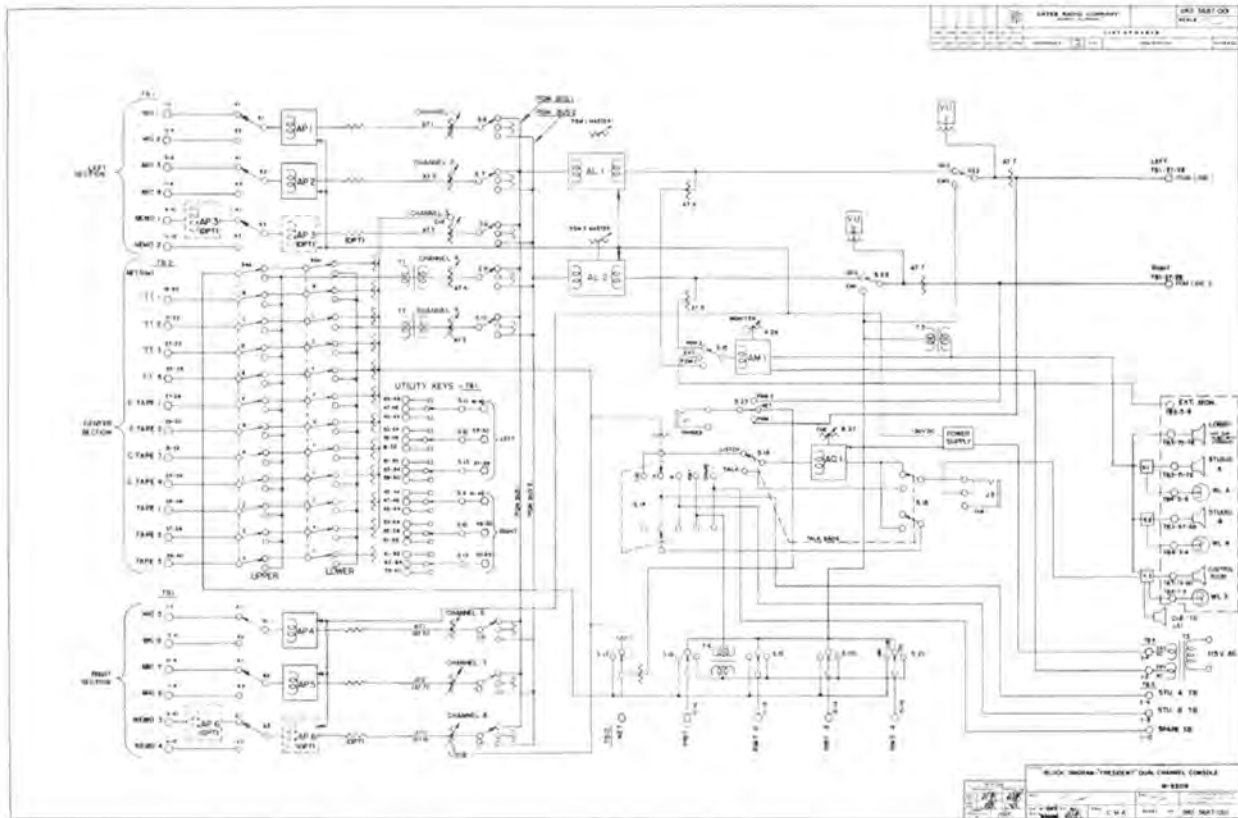

**ORDERING INFORMATION**

- The **PRESIDENT** dual channel monophonic audio control console, complete with 4 preamplifiers, 2 program amplifiers, monitor amplifier, cue-intercom amplifier, power supply and 2 external VU meters..... **M-6209**  
 Extra preamplifiers ..... **M-6034**  
 Intercom sub-station ..... **M-5303**  
 Sub-Master transistor audio console, complete with 2 preamplifiers and 1 program amplifier **M-6115**

**NOTE:** The M-6115 three channel console is the side unit of the M-6209 President and M-5564 Ambassador consoles, and is available separately for further sub-studio expansion or as a separate mixing system.

- Power supply for use with M-6115 three channel console when used as a separate mixing system ..... **M-5702**  
 External VU meter and housing for use with M-6115 three channel console ..... **M-6208**



# THE AMBASSADOR

## Single Channel Transistor Audio Control Console



The *Ambassador* is a completely transistorized 5-channel audio control console.

**MIXING SYSTEM:** Five monophonic mixing channels into one monophonic program channel utilizing low impedance, ladder type controls. Twenty-two medium and high level inputs are provided in the *Ambassador*, with an input expansion potential of 30 by using all three of the 3-position utility switches.

**MICROPHONE CHANNELS:** Four microphones switch into two channels. Channel one has input switching to accommodate two microphones in either the same or separate locations. The speaker muting may be switched along with the selected microphone to permit muting of only the studio or area with a live microphone. Channel two has identical input switching to select either microphone three or microphone four. Channel three is normally wired for two medium level inputs, selectable by the input switch. With the addition of the optional preamplifier, it can accommodate a microphone input along with a medium level, or two microphone inputs.

**MEDIUM LEVEL INPUTS:** Two multiple station, illuminated push-key switches provide 12 positions and "off" as a control center for all medium level inputs. The upper bank feeds into channel four, the lower into channel five. When the input positions are not switched into either channel, they are automatically connected to the cue bus for previewing or cueing. The switches will accommodate 11 of the medium level inputs, plus the network and four remote lines into the 12th position.

**CUE-INTERCOM SYSTEM:** A fully interlocked cue-intercom system is incorporated in the *Ambassador*. The cue position of channel three, the network input or any of the 12 push-key stations may feed the cue-amplifier—regardless of the position of the cue amplifier input selector switch.

**MUTING RELAYS:** The speaker muting relays have extra-intercom muting contacts to prevent feeding a signal into the studios when a live microphone is in use. The control room muting relay is factory wired to mute the console speaker for any type of signal when the control room microphone is in use. A cue phone jack permits headphone monitoring of the cue-intercom circuits during these periods.

**TRANSISTOR AMPLIFIERS:** The *Ambassador* is completely transistorized, incorporating Gates' exclusive Solid Statesman transistor amplifiers. The standard amplifier complement consists of:

- 2 plug-in transistor microphone preamplifiers
- 1 plug-in transistor monitor booster amplifier
- 1 plug-in transistor program amplifier
- 1 plug-in transistor cue-intercom amplifier
- 1 full level transistor monitoring amplifier
- 1 fully regulated transistor power supply

Provisions for a third optional plug-in preamplifier are included in the form of a mounting tray and wired terminations. This preamplifier may be connected ahead of the input selector switch of channel three for a dual function of microphone input plus medium level input—or, it may be wired after the input selector to provide two additional microphone inputs.

The preamplifiers have a full 20 db overload capacity above the normal level with lower distortion than most test oscillators provide. The program amplifier has a full 10 db overload factor above the +14 dbm used to feed the 6 db line isolation pad.

The monitoring amplifier provides a full +39 dbm (8 watts) output to the speakers at unbelievable low harmonic and intermodulation distortion. The response of all these amplifiers is flat within the full audible spectrum. An isolation transformer bridges the output of the monitor amplifier for emergency feed and remote program cue.

## THE AMBASSADOR

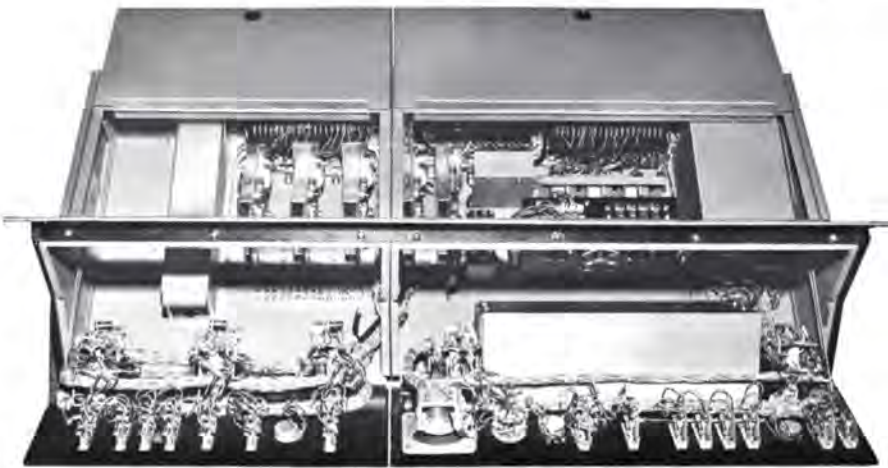

**STYLING:** The styling concept of the *Ambassador* follows the distinctive symbol of Gates' exclusive Solid Statesman line. The free floating front panel and "flip top" lid are hinged to provide full accessibility to all internal components.

The large primary control knob, designed exclusively for Gates and used on all input channels, has a prominent raised pointer to allow precise setting of any channel without visual observation.

A detachable illuminated VU meter is provided with the *Ambassador*. It may be mounted anywhere along the top rail of the console, or with the mounting clip removed, be placed on the console desk. The meter is mounted in a sturdy cast aluminum housing with interconnecting cable and plug.

The regulated power supply protects the console amplifiers from variations due to line and load regulation. In addition, the power supply ripple is reduced to the point of nonexistence to assure uniformly low noise in all of the console circuits. The power supply is also short-circuit protected to prevent damage to any of the transistors in either the power supply or amplifiers from a momentary or sustained short in any of the circuits.

**M-6115 TRANSISTOR CONSOLE:** An additional low-level unit may be purchased to be used with the two standard console sections of the *Ambassador*. This will give you a modified dual channel console providing eight mixing channels and two output program channels—the equivalent of the *President M-6209* dual channel system. Multiple console installations may require the addition of several low-level units, offering unlimited control functions. See additional data under ordering information.

### AMBASSADOR SPECIFICATIONS

#### MIXING CHANNELS:

- 5 Monophonic.

#### INPUTS:

- 6 Microphones into 3 preamplifiers.
- 11 Turntables, tape and projector inputs into 2 mixers.
- 4 Remote lines.
- 1 Network line.

#### OUTPUTS:

- 1 Program line, either regular or emergency from monitor amplifier.
- 3 Muted speaker outputs.
- 1 Unmuted speaker output.
- 2 Interlocked studio intercom speakers.
- 2 Headphone jacks.

#### AMPLIFIERS:

- 4 Plug-in transistor preamplifiers.
- 2 Microphone preamplifiers.
- 1 Booster amplifier.
- 1 Optional microphone preamplifier.
- 1 Plug-in transistor program amplifier.
- 1 Plug-in transistor cue-intercom amplifier.
- 1 Full level transistor monitor amplifier.

#### POWER SUPPLY:

- 1 Fully regulated, electronically protected transistor power supply.

#### GAIN:

- Microphone input to line output: 104 db  $\pm$ 3 db.
- Turntable input to line output: 56 db  $\pm$ 2 db.

Microphone input to speaker output: 104 db  $\pm$ 3 db.  
Turntable input to speaker output: 56 db  $\pm$ 2 db.

#### FREQUENCY RESPONSE:

$\pm$ 1.5 db from 20 to 20,000 cps in all regular program circuits (typical).  
 $\pm$ 2.0 db from 20 to 20,000 cps in all monitor speaker circuits (typical).  
 $\pm$ 1.0 db from 30 to 15,000 cps in all regular program circuits.  
 $\pm$ 1.5 db from 30 to 15,000 cps in all monitoring speaker circuits.

#### HARMONIC DISTORTION:

0.5% Maximum, 20 to 20,000 cps at +8 dbm output in all regular program circuits (typical).  
1.0% Maximum, 20 to 20,000 cps at +38 dbm in all monitor speaker circuits (typical).  
0.5% Maximum, 30 to 15,000 cps at +8 dbm output in all regular program circuits.  
0.5% Maximum, 50 to 15,000 cps at +18 dbm output in all regular program circuits.  
1.0% Maximum, 50 to 15,000 cps at +39 dbm (8 watts) in speaker outputs.

#### INTERMODULATION DISTORTION:

0.5% Maximum in program circuits.  
1.0% Maximum in monitor speaker circuits.

#### SOURCE IMPEDANCE:

Microphones—30/50 or 150/250 ohms.  
Turntable/tape/projector/remote/network—600 ohms.

## AMBASSADOR SPECIFICATIONS—continued

**LOAD IMPEDANCE:**

- Program line—600 ohms.
- Speaker outputs—4 to 16 ohms.
- Recording output—600 ohms.

**NOISE:**

- 122 dbm relative input noise on microphone channels.
- 75 dbm relative input noise on medium level channels.

**CROSSTALK:**

Below noise level in all channels.

**TRANSISTOR COMPLEMENT:**

6 Industrial type totaling 41.

**POWER CONSUMPTION:**

Approximately 40 watts at 110/117/125 volts, 50/60 cycles.

**SIZE:**

37 1/2" long, 11 3/8" high, 17 3/8" deep.

**WEIGHT:**

87 lbs. net. Packed, 245 lbs.

**CUBAGE:**

20.5.

**FINISH:**

Satin anodized black nomenclature on natural anodized aluminum background panels on a medium gray cabinet.

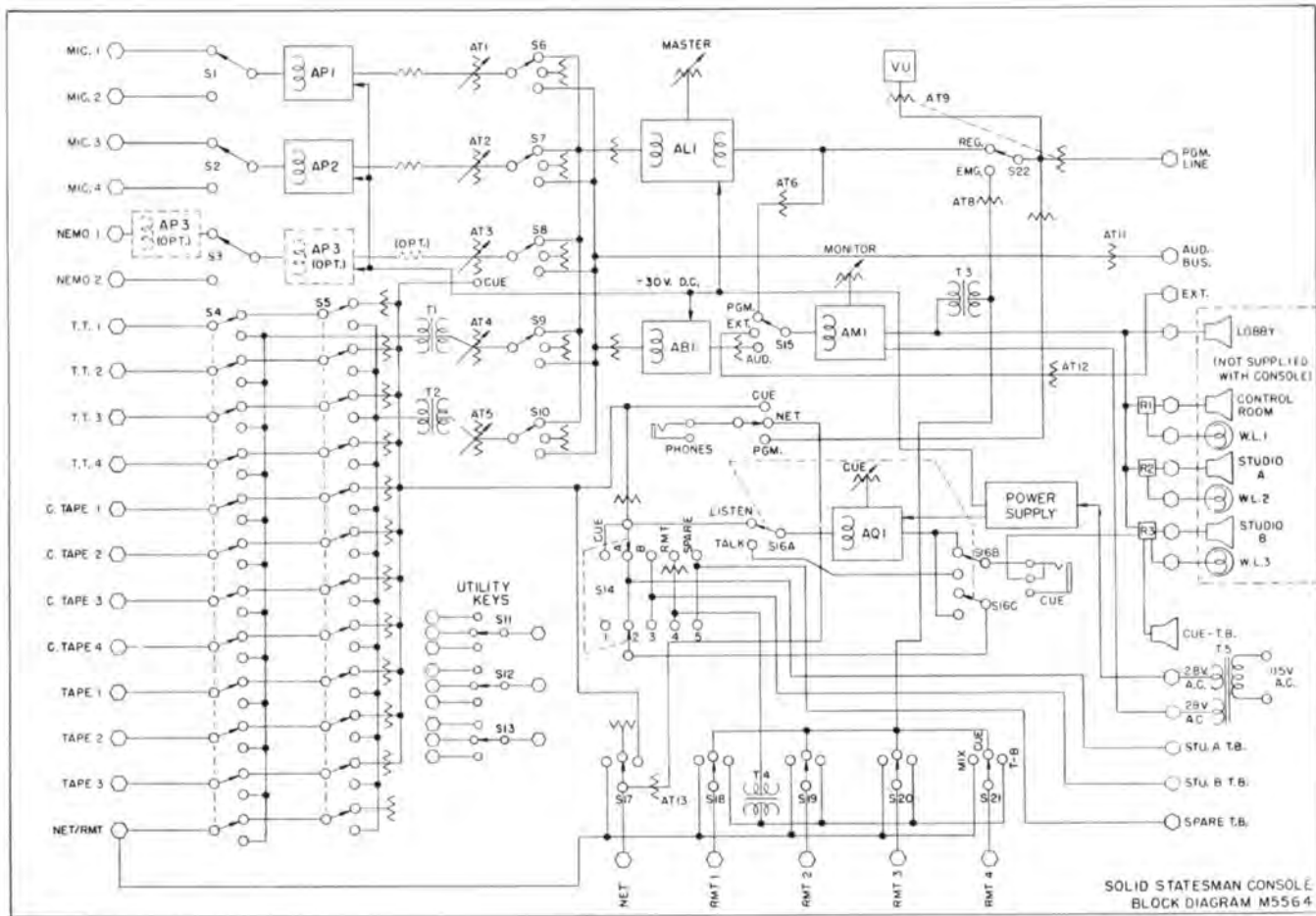

### ORDERING INFORMATION

AMBASSADOR single channel transistor audio console, complete with 2 preamplifiers, monitor amplifier, booster amplifier, cue-intercom amplifier, program amplifier, power supply and external VU meter.....	M-5564
Extra preamplifiers .....	M-6034
Intercom sub-station .....	M-5303
External VU meter and housing for use with M-6115 three channel console .....	M-6208
3-channel mixing console, complete with 2 preamplifiers and 1 program amplifier .....	M-6115
Complete sub-master audio console, including 6115 console unit, external VU meter, power supply and necessary hardware .....	M-6220



# DUALUX

## DUAL CHANNEL AUDIO CONTROL CONSOLE



Provides 9 mixing channels, 5 preamplifiers to handle 7 microphones, 4 turntables, 4 tapes, 2 high gain program amplifiers, 1 high output monitoring amplifier, 3 speaker-muting/warning light relays. Complete with dual VU meters and regulated power supply. Key switching is provided in nearly all circuits to provide maximum flexibility. Dual channel design provides two independent program channels for single point control of two separate programs. This feature allows the Dualux to handle programming for AM, FM or TV, while providing a complete channel for production facilities. If desired, the two channels may be used to feed two different programs to two different transmitters.

### SPECIFICATIONS

#### MIXING CHANNELS:

9 channels key selected to either of 2 program amplifiers, 5 microphone attenuators and 4 other channels with cue position for turntables, tapes, network.

#### INPUTS:

7 Microphones into 5 preamplifiers.  
4 Turntable, Tape and Projector inputs into 2 mixers.  
5 Remote lines.  
1 Network.

#### OUTPUTS:

2 Program lines.  
2 Audition lines.  
3 Studio speaker lines.  
3 Intercom speaker lines.  
1 Lobby speaker line.

#### AMPLIFIERS:

5 Preamplifiers.  
2 Program amplifiers.  
1 Cue-intercom amplifier.  
1 Monitoring amplifier.

#### POWER SUPPLIES:

1 Fully regulated.

#### GAIN:

Gain over all, 104 db. From turntable, network, or remote input, 61 db.  
All measurements  $\pm 2$  db.

#### FREQUENCY RESPONSE:

Over all or any segment of program circuit,  $\pm 1.5$  db, 30-15,000 cycles.

#### HARMONIC DISTORTION:

Any program circuit or segment thereof, 1% or less, 30-15,000 cycles at +8 dbm. 1.5% or less, 30-15,000 cycles at +18 dbm. Monitor amplifier 1% at +40 dbm or 10 watts.

#### SOURCE IMPEDANCE:

Preamplifier input 30/50 and 150/250 ohms balanced or unbalanced. Turntable, Tape or Projector 150 $\Omega$  unbalanced. Remote, network, 150/600 ohms balanced.

#### LOAD IMPEDANCE:

Program lines—600 ohms.  
Audition lines—600 ohms.  
Monitor speaker lines—48 ohms.  
Intercom speaker lines—600 ohms.

#### NOISE:

Microphone input to program output 60 db or better below +8 dbm output, using -60 dbm input. Turntable, network and remote inputs 70 db or better below +8 dbm output. Monitoring circuit is 60 db below +40 dbm output.

#### CROSSTALK:

All circuits or segments thereof below noise level with normal levels and control positions.

#### TUBE TYPES:

(18) EF-86, (3) 12AX7, (2) 12AU7, EL84, (1) OA2, 6AK6, 6080, GZ34. Total number: 29. Total Tube Types: 8.

#### POWER:

105/125 volts, 50/60 cycle. 155 watts.

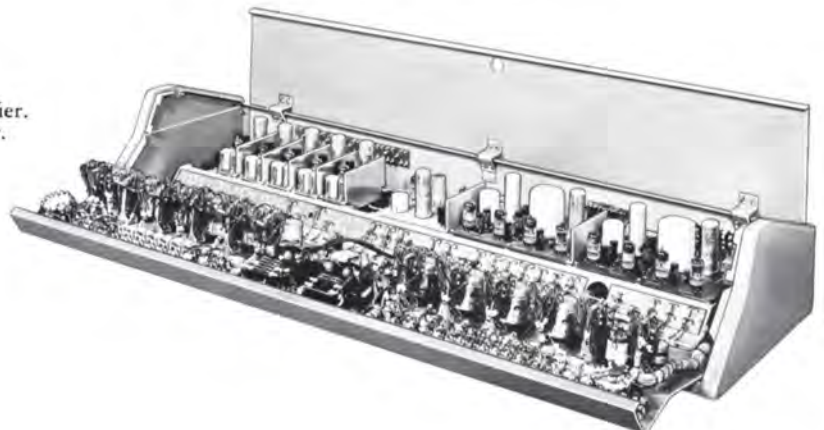

# DUALUX AUDIO CONTROL CONSOLE

## SPECIFICATIONS—continued

### SIZE:

46½" wide, 7½" high, 15" deep. (Console)  
19" wide, 7" high, 8" deep. (Rack mount power supply)

### WEIGHT:

101 lbs. net, 205 lbs. packed. Export wt. 290 lbs. 9 cu. ft.

### FINISH:

Cabinet in medium gloss gray. Front panel metallic with escutcheons in etched black and aluminum lettering. Control knobs supplied with kit of color disc inserts for coding.

### SPECIAL FEATURES:

**CUE-INTERCOM SYSTEM:** The loudspeaker and switching facilities are directly in front center of the Dualux. They may be used with M-5303 sub-station or any similar equipment for studio talkback, providing the following exclusive features:

- Non-interference with programming because of interlocking.
- 8 external intercom and 3 cueing circuits selected with front panel switch.
- Automatic cut-off of cue speaker when phone plug is inserted.

- Listen and talk-back through intercom system on following circuits:

RMT. 1—Turntable cue\* RMT. 4—Studio C  
RMT. 2—Studio A RMT. 5—Mixer Bus A\*  
RMT. 3—Studio B Mixer Bus B\*  
(\*Cannot talk on these circuits because they are interlocked.)

### METERING:

Two standard 4" illuminated VU meters recessed behind front panel for easy vision at correct eye level. One meter is across program line at all times, the second may be switched across either program lines. Both meters calibrated +8 dbm output.

### PATCH PANEL:

All main circuits are brought to terminal board and strapped together so that patch panel connections may be used where desired.

### EQUALIZER (HIGH-PASS FILTER):

Direct front panel control for Program Channel. A flat position and 3 selected response curves allow immediate elimination of hum, rumble or extraneous circuit noise at low frequencies.

### STYLING AND CONSTRUCTION:

Front panel hinges down to service. Audio amplifier strip hinges up. Panel slope correct for easy upper line vision and control.

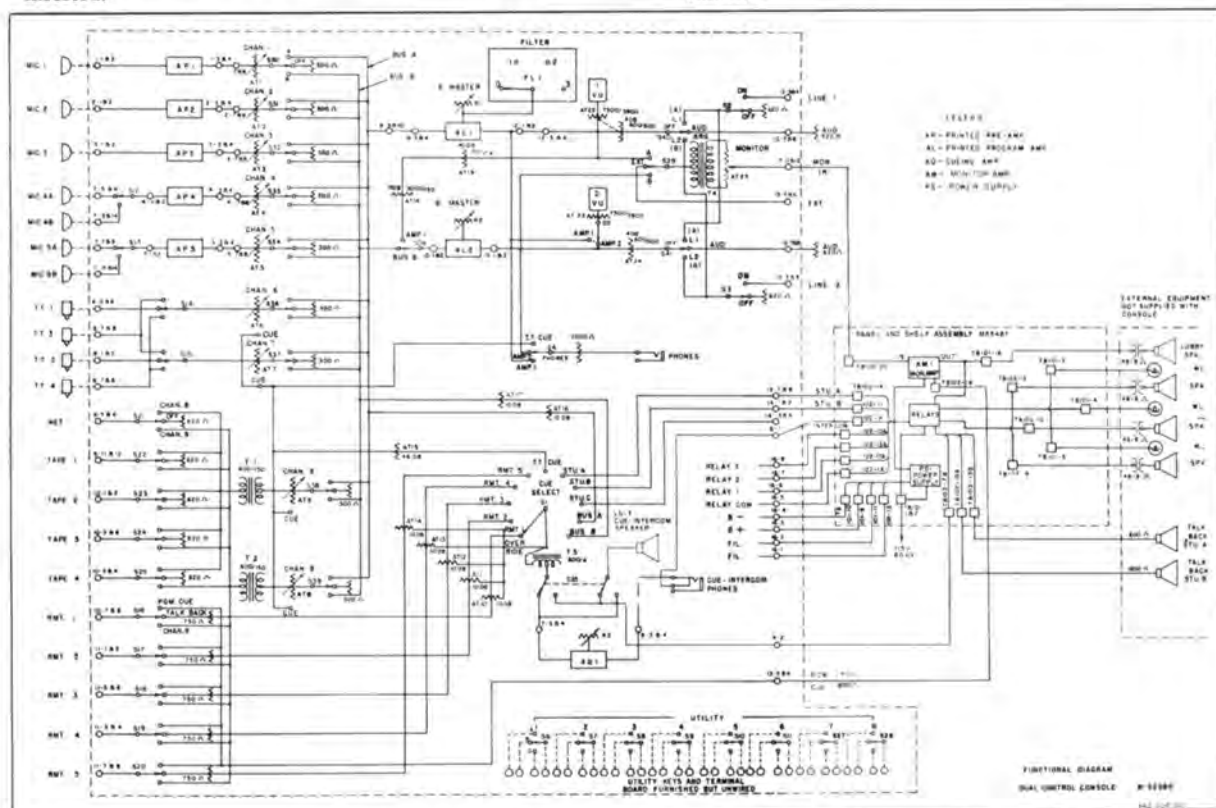

## ORDERING INFORMATION

DUALUX dual channel speech input console complete with tubes ready to use  
100% spare tube complement for above  
Intercom sub-station (optional) for studio use  
Desk (optional)  
Preamplifiers (room provided for two extra)  
Extra relays for additional muting, etc.

M-5236B  
TK-449  
M-5303  
M-5372  
M-5304A  
AK-11939



# GATESWAY

## AUDIO CONTROL CONSOLE



The Gatesway eight channel audio console fulfills all the requirements of a modern speech input system for broadcasting or recording. One of the most comprehensive audio systems ever built, the Gatesway provides for audio control of control room, two studios, and an announce booth, with ample facilities for turntable, tape, cartridge-tape, network and remote program sources.

Eight step type mixing channels accommodate five microphones into four preamplifiers (15 microphones by use of utility keys), four turntables, four tapes, network, and multiple remote lines. The Gatesway includes a 10 watt ultra linear amplifier, variable high-pass filter, inbuilt cue-intercom, and five unwired utility keys for individual needs. Twenty-seven keys accommodate 52 switching functions. A fully regulated power supply is provided as a separate rack mounted unit.

### SPECIAL FEATURES:

**RELAYS:** 3 provided. Telephone type, with contacts for muting loudspeakers and operating 115 volt circuit for warning lights up to 60 watts per light. Room for 2 added relays on chassis where unusual muting or control requirements exist. Relays operate from console power supply.

**CUE AMPLIFIER:** Fixed pads at all circuits provide adjusted uniform input level for proper cue speaker operation. Also provides proper level for remote talk-back and studio intercom system.

**CUE SPEAKER/AMPLIFIER SELECTOR:** Selects cue speaker/amplifier for both talk and listen into: all remote lines, 3 studios and utility line. Selects to listen only on turntables, tape recorders, audition buss program line and one external source.

**UTILITY KEYS:** 5 provided, unwired, located to left upper center of VU meter. Provided for specific requirements of individual installation such as additional remote lines, tape inputs, etc. 4 keys are double pole-3 position. One is 4 pole-2 position.

**OUTPUT EMERGENCY KEY:** Located above master gain. In case of failure of program amplifier, the output of the monitoring amplifier may be instantly connected to the program line. Does not disconnect loudspeakers.

**MONITOR INPUT KEY:** Located above monitor gain control. Allows switching of monitoring

amplifier to: (a) padded output of program amplifier, (b) audition buss, and (c) external pair for any other input.

### SPECIFICATIONS

#### MIXING CHANNELS:

8 ladder type. Ninth mixing channel may be added in place of monitor gain control which is moved to chassis of monitor amplifier.

#### INPUTS:

5 Microphones into 4 preamplifiers.  
4 Turntables.  
4 Tape or projectors.  
4 Remote lines.  
1 Network.  
1 External monitor input.

#### OUTPUTS:

1 Program line.  
1 Audition line.  
2 Studio speaker lines.  
3 Intercom speaker lines.  
1 Lobby speaker line.  
1 Control room speaker line.  
1 Control room intercom line.

#### AMPLIFIERS:

4 Preamplifiers (space provided for two additional preamplifiers).  
1 Program amplifier.  
1 Monitoring amplifier.  
1 Monitor booster amplifier.  
1 Cue-intercom amplifier.

#### POWER SUPPLY:

1 Fully regulated.

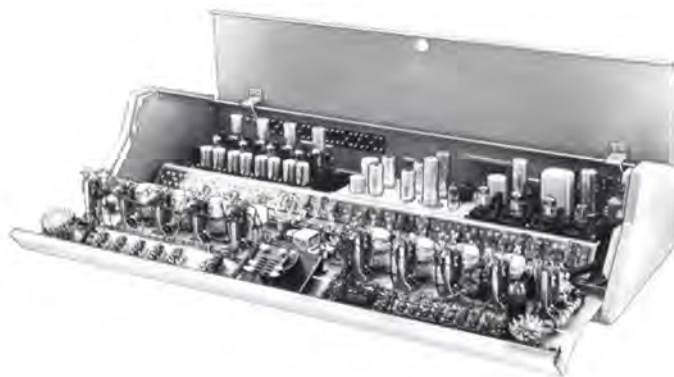

# AUDIO CONTROL CONSOLE

## SPECIFICATIONS—continued

**GAIN:**  
From mic input to program output, 104 db. From remote line, net, tape and turntables to program line output, 61 db.

**FREQUENCY RESPONSE:**  
±1.5 db 30-15,000 cycles (standard mode of operation). ±2.0 db 30-15,000 cycles (emergency circuits).

**HARMONIC DISTORTION:**  
1% or less 30-15,000 cycles all program circuits measured at +8 dbm output. 1% or less 50-15,000 cycles all monitoring circuits measured at +40 dbm (10 watts).

**SOURCE IMPEDANCE:**  
Mic inputs ..... 30/50  
TT inputs ..... 150/250 ohms  
Tape inputs ..... 500/600 ohms  
Net input ..... 600 ohms  
Rmt inputs ..... 600 ohms  
External Monitor input ..... 150 ohms

**LOAD IMPEDANCE:**  
Program line—500/600 ohms.  
Audition line—150 ohms.  
Monitor speaker lines—48 ohms.  
Intercom speaker line—600 ohms.

**NOISE:**  
Program circuit: 60 db or better below +8 dbm output, measured at -60 dbm input. Monitoring amplifier: 60 db below +40 dbm output.

**CROSSTALK:**  
Below microphone channel noise level with normal inputs and control positions.

**TUBE TYPES:**  
(13) EF86/6267 (4) 12AX7, (2) EL84, (1) 12AU7, 6AK6, 6080, GZ34, OA2.

**POWER SOURCE:**  
105-125 volts, A.C., 50/60 cycles.

**POWER CONSUMPTION:**  
105 watts.

**SIZE:**  
39" wide, 15" front to back, 7½" high. Height (lid up), 12½".

**WEIGHT AND CUBAGE:**  
Net, Console, 52 lbs. Power supply and monitoring unit, 39 lbs. Total packed weight, 175 lbs. Cubage: 8.5 cu. ft.

**FINISH:**  
Cabinet in medium gloss gray. Front panel metallic with escutcheons in etched black and aluminum lettering.

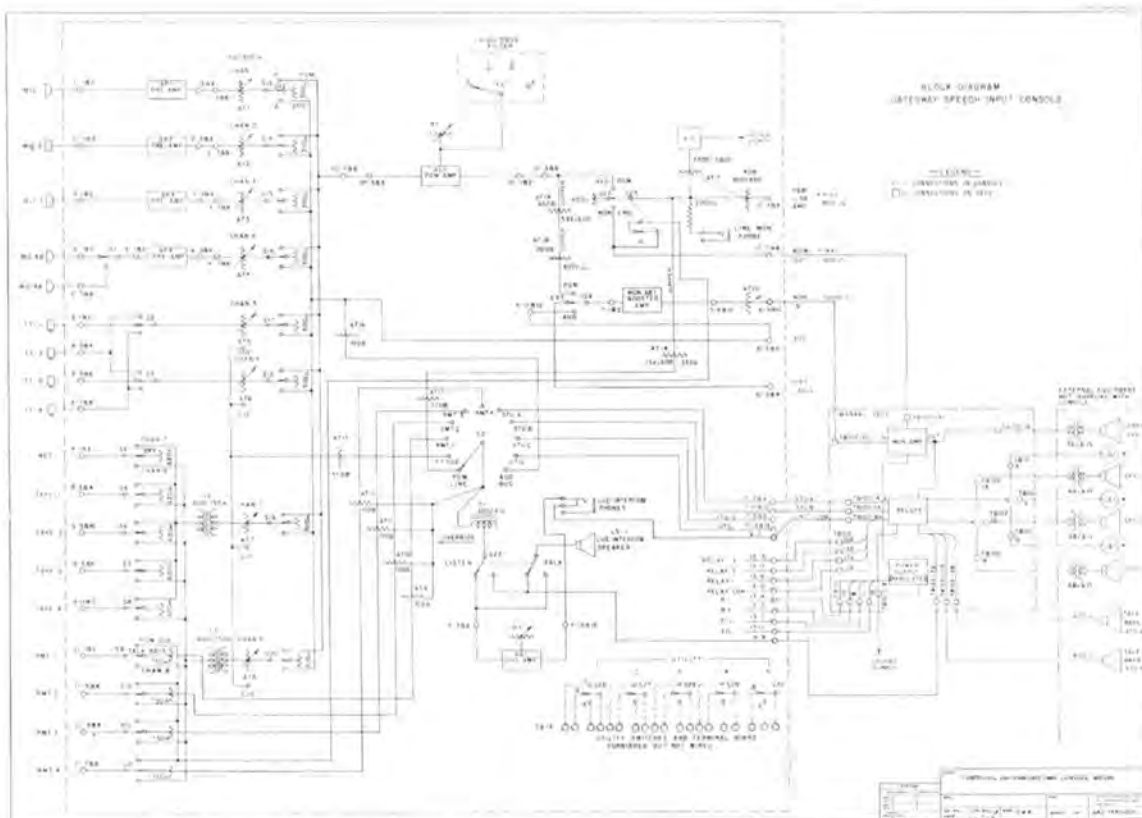

## ORDERING INFORMATION

Gatesway speech input console with tubes and ready to install	M-5133B
Extra preamplifiers for above	M-5304A
Extra muting relays for above	AK-11939
Intercom sub-station for above	M-5303
100% spare tube complement for above	TK-451





# STEREO YARD

## Audio Control Console



The Gates Stereo Yard is a completely new compact 8 channel console designed for full stereophonic operation. It provides the broadcaster with three full stereo microphone channels, utilizing six microphone preamplifiers and five high level stereo mixing channels.

Dual stereo mixer controls are used in all 8 mixing channels. These are low impedance step type dual attenuators of extremely high quality.

The console is supplied with 6 preamplifiers, 2 matched program amplifiers, 2 monitor amplifiers, 2 booster amplifiers, a cue amplifier and 2 regulated power supplies. In addition, 6 isolation transformers are included to provide balanced high level stereo inputs on three full stereo mixing channels. The twin matched program amplifiers provide unmatched high fidelity broadcasting. The monitoring amplifiers are 10 watt ultra linear models. Each "right" channel microphone preamplifier is provided with a selector switch allowing the input to the "right" preamplifier to be

bridged off of the output of the "left" preamplifier. One microphone can then feed both "right" and "left" program amplifiers while maintaining channel separation.

A front panel selector switch permits instantaneous selection of operation modes for simultaneous stereophonic or separate feed to the individual program channels. This flexibility means the Gates Stereo Yard Console can be used in single channel monaural station applications as well as stereo broadcasting.

Separate from the console are three standard rack mount units including — the right channel program amplifier, two rack mount units each containing a regulated power supply, ten watt ultralinear monitor amplifier and speaker muting/warning light relay unit. This isolation effectively reduces crosstalk between the two program channels and keeps the high level audio, AC fields and switching transients at a location apart from the low level input circuits. These units all supplied as standard equipment.

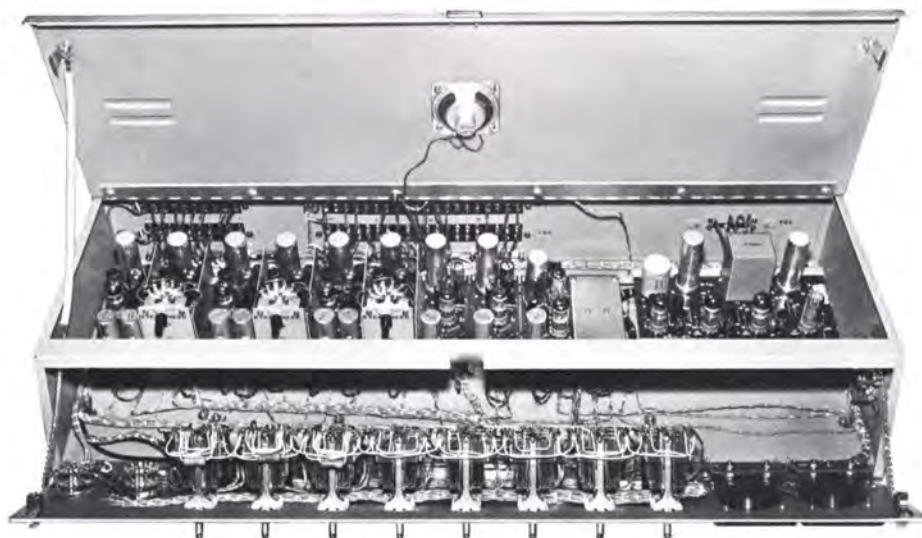

# STEREO YARD CONSOLE

## SPECIFICATIONS

### GAIN: (Each Channel)

- (a) Preamplifier input to program output, 103 db.
- (b) Preamplifier input to monitoring amplifier output, 130 db.
- (c) High level channel input to program line output, 60 db.
- (d) High level channel input to monitoring amplifier output, 87 db.

### FREQUENCY RESPONSE: (Each Channel)

Program circuits  $\pm 1\frac{1}{2}$  db, 20-20,000 CPS.  
 Monitor circuits  $\pm 2$  db, 30-15,000 CPS.

### DISTORTION:

Program channel: 1% or less at +8 dbm output level.  
 Monitor channel: 1% or less at +40 dbm (10 watts) output level.

### NOISE:

Program circuits: 60 db or better below +8 dbm output with 60 dbm input. Equivalent noise input is -120 dbm.  
 Monitor circuits: 62 db below +40 dbm output.

### CHANNEL SEPARATION:

50 db or more under normal conditions.

### STEREO INPUTS:

3 microphone, 2 turntable, 2 tape and one utility.

### IMPEDANCES:

Microphone input to preamplifier, 30/50 - 150/250 ohms.  
 Turntable input to mixers, 150/250 ohms.  
 Tape and utility input to mixers (transformer isolation) 150/250 - 500/600 ohms.  
 Program line outputs, 500/600 ohms.  
 Monitor amplifier outputs, 8/16 ohms.



Two Rack Mounted Monitor Amplifier Supply Assemblies are included as standard equipment.

### POWER:

105-125 volts AC, 50/60 cycles at 260 watts.

### TUBES:

(2) 0A2, (2) 5V4, (1) 6AK6, (1) 6X4, (2) 12AU7, (7) 12AX7, (4) EL84, (20) EF86/6267, (2) 6080.

### SIZE:

Console—36 $\frac{1}{8}$ " wide, 13 $\frac{7}{8}$ " deep, 6 $\frac{3}{8}$ " high. Rack space required for external units—19" x 26 $\frac{1}{4}$ ".

### WEIGHT AND CUBAGE:

200 lbs. packed weight. 11.0 cu. ft.

### FINISH:

Cabinet medium gray. Panel, anodized aluminum in natural and black.

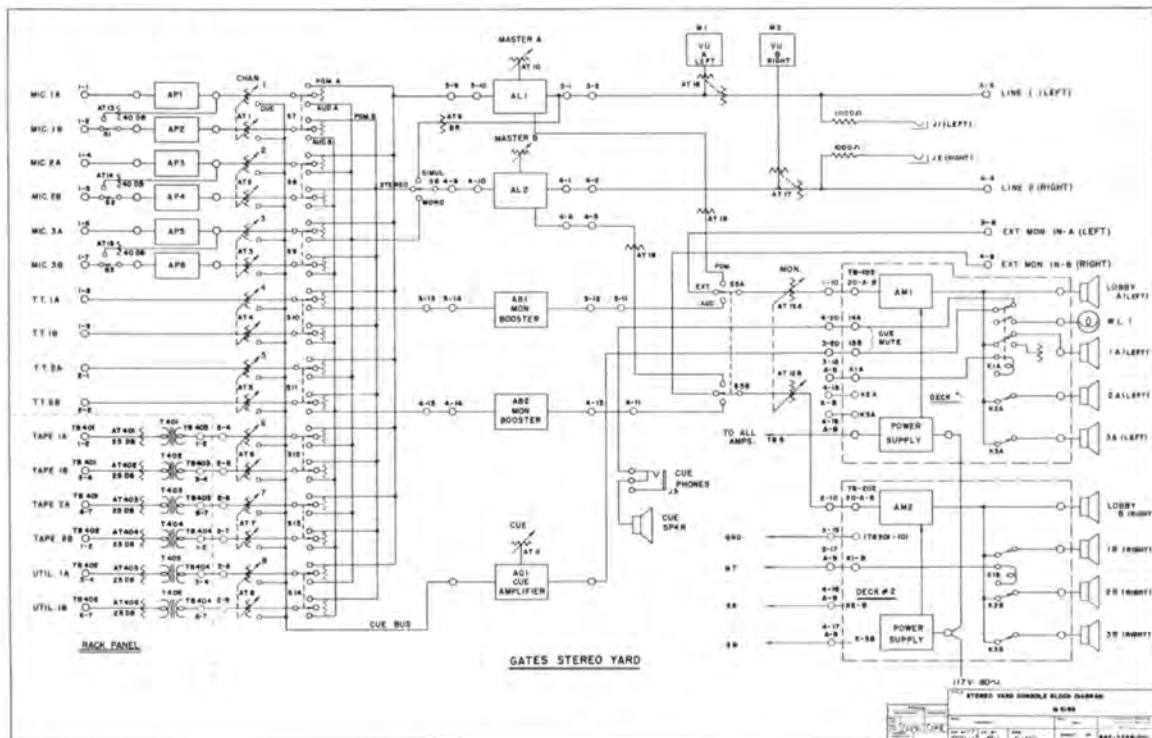

## ORDERING INFORMATION

Stereo Yard Console complete with six preamplifiers, 2 rack mount chassis each containing regulated power supply, monitor amplifier and 3 muting relays, and one chassis containing the right channel program amplifier all containing 100% set of tubes ..... M-6188  
 Spare 100% tube kit for M-6188 Stereo Yard ..... TK-417  
 Extra muting relay ..... AK-12626  
 Speaker matching transformer ..... A-30601



# YARD

## Audio Control Console



The Yard is one of the industry's most widely used speech input systems. With 13 inputs and 8 mixing positions it provides all control room facilities normally needed in the operation of medium-size radio or TV stations.

Outstanding features include 8 mixing channels key selected into the program or audition bus accommodating many combinations of microphones, turntables, tape playbacks and projectors with provision for network and remote lines; a self-contained cue amplifier and speaker for turntable and projector channels; an ultra-linear 10 watt monitoring amplifier; and a regulated power supply for uniformity of performance.

### SPECIFICATIONS

#### MIXING CHANNELS:

Eight channels are each key selected into the program or audition bus. Mixing attenuators are low impedance step-type controls. Channels 6 and 7 have cue position connections at infinity (off). This cue feeds the input from channels 6 and 7 to cueing amplifier/speaker for turntable, tape or projector cue up. Muting relays operate in conjunction with the mixer keys and are wired to the first three channels. Sufficient contacts are on all channel keys where more muting relays are added. Audition mixer bus is switch selectable to either the monitoring amplifier or external terminals for recording.

#### INPUTS:

- 6 Microphones into 3 preamplifiers.
- 2 Turntables.
- 2 Tape or projector.
- 2 Remote lines
- 1 Network.

#### OUTPUTS:

- 2 Program lines.
- 1 Audition line.
- 2 Studio speaker lines.
- 1 Cue speaker line.
- 1 Lobby speaker line.

#### AMPLIFIERS:

- 3 Preamplifiers.
- 1 Program amplifier.
- 1 Cue amplifier.
- 1 Monitor amplifier.
- 1 Monitor booster amplifier.

#### POWER SUPPLY:

Fully regulated employing a 4-tube circuit and electronic filter for low noise. All filament, plate and relay voltages are provided.

#### GAIN:

(a) Any amplifier input to program line output; 103 db. (b) Any preamplifier input to monitoring amplifier output. 130 db. (c) Any turntable, tape projector or network input to monitoring amplifier output: 87 db.

NOTE: Gain of monitoring amplifier is reduced by fixed pad when operating from output of program amplifier. All gain measurements stated are +2 db.

#### FREQUENCY RESPONSE:

Program circuits +1½ db, 30-15,000 cycles. Monitor circuits +2 db, 30-15,000 cycles.

#### HARMONIC DISTORTION:

Program circuit 1% or less 30-15,000 cycles at +8 dbm. Monitor circuit 1% or less 50-15,000 cycles at +40 dbm or 10 watts.

#### SOURCE IMPEDANCE:

Microphone input to preamplifiers, 30/50 - 150/250 ohms. Turntable, projector, tape input to mixer, 150/250 ohms. Remote line, network input to mixer, 150/250 - 500/600 ohms. Remote line, network input to mixer, 150/250 - 500/600 ohms. Program line output, 500/600 ohms. Monitoring amplifier output, 8 or 16 ohms.

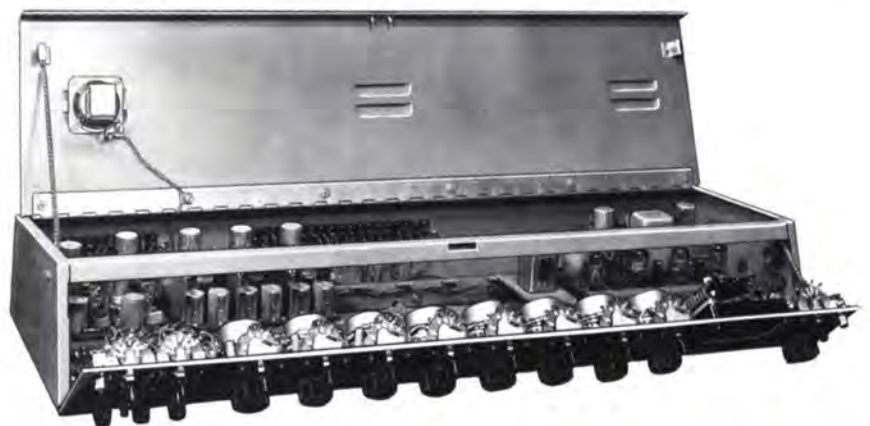

# YARD AUDIO CONTROL CONSOLE

## SPECIFICATIONS—continued

### LOAD IMPEDANCE:

Program lines—500/600 ohms.  
Audition line—20K ohms.  
Monitor speaker lines—48 ohms.

### NOISE:

Program circuit including preamplifier 60 db or better below +8 dbm output with -60 dbm input. Equivalent noise input is -120 dbm. Monitor circuit 62 db below +40 dbm output.

### CROSSTALK:

Below noise level in all channels.

### TUBE TYPES:

(10) EF86/6267, (4) 12AX7, (1) 12AU7, (1) 6AK6,  
(1) GZ34, (1) 6080, (1) OA2, (2) EL84.

### TOTAL NUMBER OF TUBES:

21.

### TOTAL TUBE TYPES:

8.

### POWER CONSUMPTION:

105-125 volts, A.C., 50/60 cycles at 130 watts.

### SIZE:

Console, 36" wide, 5 $\frac{3}{4}$ " high, 12 $\frac{1}{2}$ " deep. Power/monitoring/muting unit, 19" wide, 7" high, 8" deep. Front panel drops down to service. Optional desk, 30" high, 36" wide, 25 $\frac{1}{2}$ " deep with desk (front to console) depth 12".

### WEIGHT:

77 lbs. net, 90 lbs. packed.

### CUBAGE:

7.1 cu. ft.

### FINISH:

Cabinet medium gray. Panel anodized aluminum in natural and black. Knobs furnished with color decal kit. Desk, medium gray to match cabinet of YARD.

## SPECIAL FEATURES:

The preamplifiers, program and monitor amplifiers are all individual units easily removable for servicing. Each of the three preamplifiers has an input key to select two microphones to each preamplifier.

**CUE AMPLIFIER:** A standard assembly with its own front panel level control. Cue speaker is mounted in the console lid. Output from remote line and mixing channels 6 and 7 are switchable to the cueing amplifier. The YARD is the only console in its price range with an inbuilt cueing system.

**MONITOR BOOSTER:** This added YARD feature provides a separate voltage amplifier to bring the audition bus up to bridging level. This makes it possible to switch the monitor from program to audition with no change in speaker volume. The output of the booster amplifier is also brought out to a pair of terminals for recording direct from the audition bus. The monitoring amplifier, power supply and muting relay unit are in a separate unit.

**MUTING RELAYS:** Provision is made for five relays with two supplied as standard. Contacts are provided for both speaker muting and warning lights. Muting relays are of a high quality telephone type and operate from control keys on console in a wide variety of circuit combinations to suit the purchasers' desires.

**REMOTE/NET KEYS:** Three incoming lines are selected by three keys to the extreme left. All lines feed through a line isolation transformer. The two remote lines are selectable to "program cue," "cueing amplifier" and "mix." The "network" key may be used for a remote line if desired.

**VU METER:** Standard 4" illuminated, flush mounted meter.

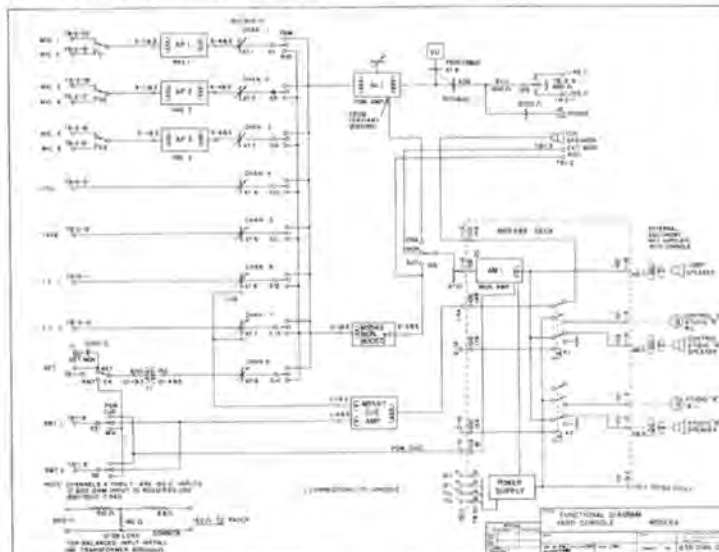

## ORDERING INFORMATION

Yard Speech Input Console with tubes and ready to install  
Extra preamplifiers for above  
Extra muting relays for above  
100% spare tube complement for above

M-5526A  
M-5304A  
AK-12626  
TK-446



# STUDIOETTE

## Audio Control Console

The Studioette is a superb program control console for the small size audio system. Its high fidelity performance makes it ideal for AM, FM or TV station use or for recording studios.

Completely self-contained, the Studioette provides 4 mixing channels utilizing high quality step type attenuators. Each is key selected to feed either the program or monitor bus. This four channel console with generous key switching facilities accommodates four microphones into two preamplifiers, three turntables, two tapes or projectors, network and three remote lines. Three utility keys are provided for your individual needs. The Studioette also includes a high gain program amplifier, 10 watt ultra linear monitoring amplifier, dual muting and warning light relays, 4" illuminated VU meter, cueing facilities for turntables, net, tapes and remotes, and output emergency key. Space is provided for a third preamplifier and two additional muting relays. These add-on facilities may be used



with the spare utility key to accommodate two additional microphones.

The Studioette is a perfect blending of work-horse versatility and functional design. The unusual generosity of controls, high performance standards, service ease and smart commercial appearance combine with quality engineering and materials to satisfy the most demanding broadcaster.

### SPECIFICATIONS

#### MIXING CHANNELS:

Four mixing channels, each key selected to either the program or audition bus. Audition bus feeds an external pair of terminals for recording, etc. Each attenuator is a low impedance step type control. Channels 3 and 4 have cue position at infinity or off position of the mixer. The block diagram excellently illustrates the function of the mixer as related to circuit control.

#### INPUTS:

- 4 Microphones into 2 preamplifiers.
- 3 Turntables, 2 tapes or projectors into 1 mixer.
- 3 Remote lines.
- 1 Network.
- 1 External Monitor input.

#### OUTPUTS:

- 1 Program line.
- 1 Audition line.
- 2 Studio speaker lines.
- 1 Lobby speaker line.
- 1 Turntable cue.
- 1 Remote-tape cue.

#### AMPLIFIERS:

- 2 Preamplifiers.
- 1 Program amplifier.
- 1 Monitor amplifier.
- 1 Monitor booster amplifier.

#### POWER SUPPLY:

Self-contained in the Studioette and supplies all voltages for filament and plate requirements. Extra capacity is available for the optional third preamplifier and optional muting relays.

#### GAIN:

- (a) Any preamplifier input to program line output 103 db  $\pm$  2 db.
- (b) Any preamplifier input to monitoring amplifier output 140 db  $\pm$  3 db.
- (c) Any turntable, net, tape or remote line input to program line output 63 db  $\pm$  2 db.
- (d) Any turntable, net, tape or remote line input to monitoring amplifier output 100 db  $\pm$  3 db.

#### FREQUENCY RESPONSE:

- Program circuits  $\pm$  1 1/2 db 30-15,000 cycles.
- Monitor circuit  $\pm$  2 db, 30-15,000 cycles.

#### HARMONIC DISTORTION:

- Program line maximum of +8 dbm at 1% or less distortion.
- Monitoring amplifier maximum of +40 dbm (equivalent to 10 watts) at 1% or less distortion.

#### SOURCE IMPEDANCE:

- Microphone input to preamplifiers, 30/50 and 150/250 ohms.
- Turntable inputs, 150/250 ohms. Tape, network, remote line inputs, 500/600 ohms. Program line output, 500/600 ohms. Monitoring amplifier output, 8 and 16 ohms.\*
- \*When monitoring amplified is used as emergency program amplifier, a bridging pad converts to 500/600 ohms impedance.

#### LOAD IMPEDANCE:

- Program lines—500/600 ohms.
- Audition line—20K ohms.
- Speaker lines—48 ohms.

#### NOISE:

- Program circuits including preamplifier, 60 db below +8 dbm output with -60 dbm input. Equivalent noise input is -120 dbm. Monitor (audition) circuits, 55 db below +40 dbm output.

#### CROSSTALK:

- Below noise level.

#### TUBE TYPES:

- Preamplifiers, each (2) EF86/6267.
- Program amplifier, (3) EF86/6267, (1) 12AU7.
- Monitor Booster amplifier, (1) 12AX7.
- Monitor amplifier, (2) 12AX7, (2) EL84.
- Power supply, (2) OA2, (1) GZ-34.

#### TOTAL NUMBER OF TUBES:

- 16.

#### TOTAL TUBE TYPES:

- 6.

# STUDIOETTE AUDIO CONTROL CONSOLE

## SPECIFICATIONS—continued

### POWER CONSUMPTION:

105-125 volts, A.C., 50/60 cycles, 120 watts.

### SIZE:

24" wide, 8<sup>1</sup>/<sub>4</sub>" highest point, 17" deep.

### WEIGHT:

Net weight, 55 lbs. Packed weight, 70 lbs.

### CUBAGE:

4.6 cu. ft.

### FINISH:

Cabinet is medium, hand rubbed, gloss gray. Panel in second tone of gray with escutcheons in anodized black and natural aluminum.

### SPECIAL FEATURES:

**CUEING:** When mixing channels 3 and 4 are OFF position, they automatically connect to a pair of terminals to which a cueing amplifier may be attached. The Gates M-5377 cueing amplifier is ideal for this service. With this feature, all circuits feeding mixing channels 3 and 4 may be prechecked, including turntables, network, tape inputs and remote lines.

**MONITOR BOOSTER:** A two-stage printed wiring amplifier between the audition bus of the mixer and input to the monitoring amplifier. This feature provides balanced level between the program and audition bus so when switching the operator needs not readjust gain settings.

**RELAYS:** Two are supplied as standard with space for two additional relays where needed. These relays operate in conjunction with microphone keys S1 and S2 and mixing keys (see functional diagram). Any muting arrangement is possible. Relay contacts are supplied for operation of warning lights as well as loudspeaker muting.

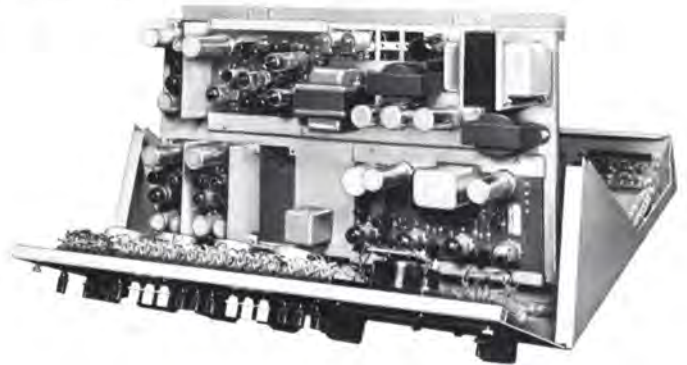

Studioette top cover is completely removed. Front panel hinges out to reach every "behind the panel" component. The amplifier deck hinges up so that muting relay contacts are at finger tip when touch-up burnishing is required.

**ADDITIONAL FACILITIES** include an output emergency key where the program line may be switched to the monitoring amplifier output in case of a noisy tube, etc., developing in the program amplifier during a broadcast. A monitor selector key switches the monitoring amplifier input to: (1) program line for monitoring, (2) external terminals for external input, and (3) audition bus of the mixing system. A headphone jack is across the program line at all times. The 4" illuminated VU meter is flush mounted. The meter is connected to program line and indicates +8 VU at 0 scale reading.

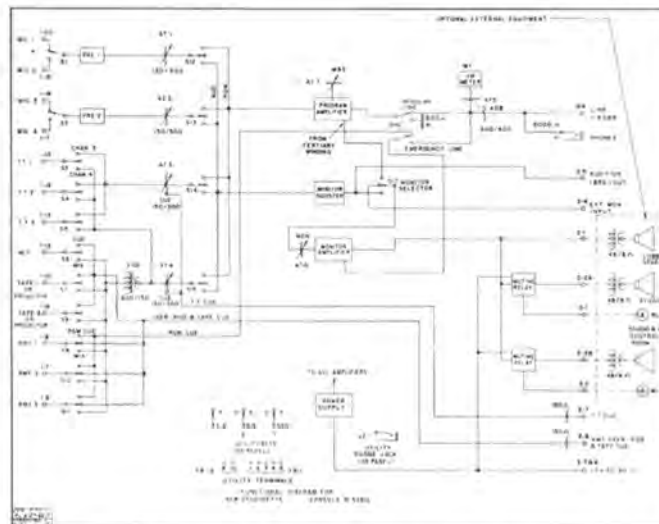

## ORDERING INFORMATION

Studioette console complete with tubes, two preamplifiers and two muting relays, ready to use

Extra preamplifier for above

Extra muting relay for above

Speaker matching transformer

Spare 100% tube kit for Studioette

M-5381A

M-5304A

AK-12626

A-30601

TK-440



# TV-10

## Ten Channel Audio Control Console



The Gates Model TV-10 audio console is one of the most outstanding consoles on the market for television and recording studios. This is a ten channel speech input system specifically designed for audio control in large television productions. For recording, it provides the input channels so necessary for the demands of professional recording studios.

Ten mixing channels are key selected into two program buses, each with its own program amplifier. Each program bus has its own submaster gain control, and any or all input channels may be switched to either one of the two

submasters and faded in and out as a group. Or, either submaster may be used simultaneously or individually with no switching required.

All ten channels can be equipped with microphone preamplifiers, or the six preamplifiers that are standard equipment may be used and the remaining four high level channels utilized for turntables, tape devices, projectors, remote lines or network. The provision of seven unwired utility keys permit switch control of all projectors, tapes and turntables into one channel.

### SPECIFICATIONS

#### MIXING CHANNELS:

- 10 Monophonic.

#### INPUTS:

- 6 Microphones into 6 preamplifiers.
- 4 Medium level inputs into Channels 7-10 (may be used with 4 additional microphones by addition of 4 optional preamps).
- 21 Additional inputs by use of utility keys.

#### OUTPUTS:

- 3 Program lines.
- 3 Muted speaker outputs.
- 1 Unmuted speaker output.
- 4 Headphone jacks.

#### AMPLIFIERS:

- 12 Preamplifiers.
- 6 Microphone preamplifiers.
- 2 Booster amplifiers.
- 4 Optional microphone preamplifiers.
- 2 Program amplifiers.
- 1 Monitor amplifier.

#### POWER SUPPLIES:

- 2 Fully regulated.

#### GAIN:

- Microphone input to line output: 106 db  $\pm$  2 db.
- High level input to line output: 65 db  $\pm$  2 db.

#### FREQUENCY RESPONSE:

- $\pm$  1.5 db 30 - 15,000 cps. in all regular program circuits.
- $\pm$  2 db 30 - 15,000 cps. in all monitor speaker circuits.

#### HARMONIC DISTORTION:

- 0.5% maximum 50 - 15,000 cps. at +18 dbm output in regular program circuits.

- 1.0% maximum 50 - 15,000 cps. at +40 dbm output in monitor speaker circuits.

#### SOURCE IMPEDANCE:

- Microphones—30/50 or 150/250 ohms.
- High level—150/250 ohms.

#### LOAD IMPEDANCE:

- Program line—600 ohms.
- Speaker outputs—4 to 16 ohms.

#### NOISE:

- 120 dbm relative input noise on microphone channels.
- 75 dbm relative input noise on high level channels.

#### CROSSTALK:

- Below noise level in all channels with normal levels.

#### TUBE TYPES:

- (20) 6267/EF86, (6) 12AU7, (2) 12AX7, (2) 5V4, (2) 6080, (2) EL84, (3) OA2.

#### TOTAL NUMBER OF TUBES:

- 37.

#### TOTAL TUBE TYPES:

- 7.

#### POWER:

- 105/125 volts, 50/60 cycle, 230 watts.

#### SIZE:

- Console 39" long, 7 $\frac{1}{2}$ " high (lid down), 12 $\frac{1}{2}$ " with lid raised, 15 $\frac{1}{2}$ " deep.

- Two standard rack mounted units: (1) program amplifier and power supply, 7" high, 24" deep. (1) monitor amplifier-relay-power supply, 7" high, 8" deep. Front panel drops down to service.

# TV-10

## SPECIFICATIONS—continued

### WEIGHT AND CUBAGE:

Console, 50 lbs. Power supply, 80 lbs. Total packed weight, 250 lbs. 16 cu. ft.

### FINISH:

Medium gray with second tone of light gray. Escutcheons anodized black. Knobs black with color disc inserts. Panel and shelf units in medium gray.

### SPECIAL FEATURES:

#### Terminations:

To inside rear of both console and panel and shelf units.

### Patch Panel:

Terminals with jumpers for insertion of patch jacks at all major circuits (see Block Diagram).

### Utility Keys:

7 keys (4 bottom center above jacks and 3 top left level) are supplied with terminal strips but unwired. Each key has 3 positions, or 7 keys may be wired to handle 21 low impedance circuits as desired by user. It is well to re-emphasize the patch panel facility (above) to fully determine the maximum flexibility of the TV-10 console.

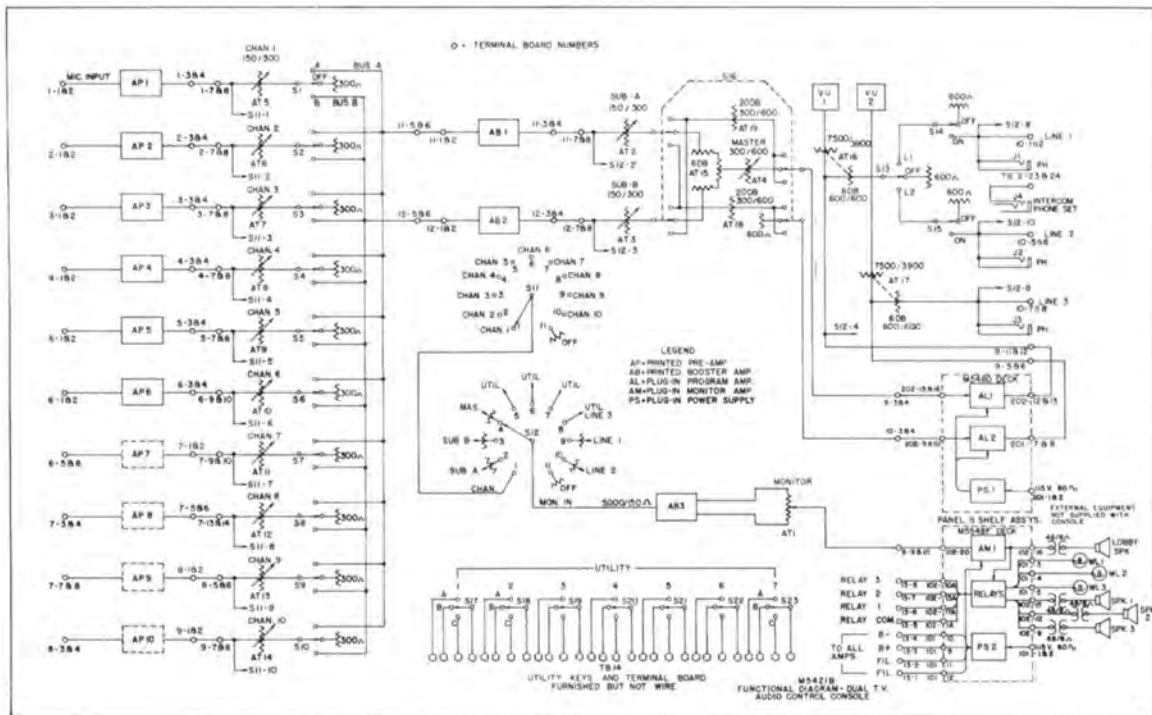
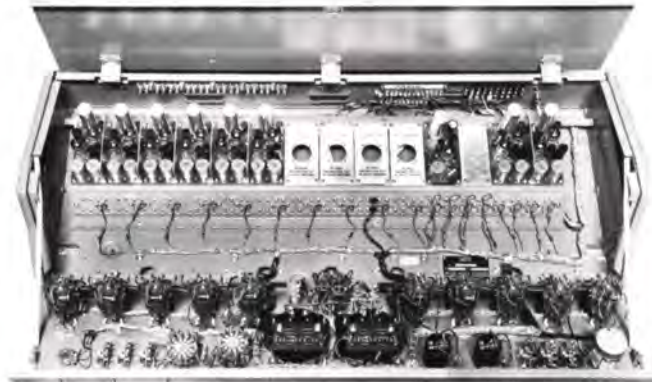

## ORDERING INFORMATION

TV-10 Speech Input Console complete with tubes, two regulated power supplies (one panel and shelf assembly, one drop-panel housing), dual program amplifiers, dual power supplies, relay unit and monitoring amplifier

Extra preamplifier with tubes

Spare tube complement for TV-10 Console

Optional Desk

M-5421B

M-5304A

TK-445

M-5371



# PORTABLE AUDIO CONSOLE

**Keldon Model KD-20A**



This portable audio console is a compact 68 pound all transistorized unit designed for quick and easy program origination. Includes two 3 speed 12-inch turntables with transistorized amplifiers and solid state power supply. Mixing is provided for turntables, microphones and a remote input. Each of the turntables has individual mixing controls. Two microphones and the remote input are selectable by a three-position switch. (High level source, such as tape recorder or remote amplifier, can be fed into remote input.) Includes bridging output for feeding external PA.

The console is a one-piece fiberglass unit. The legs are detachable and the unit has convenient handles for carrying. Base of console is flat when legs are in storage position, permitting ease of transportation.

### SPECIFICATIONS

- FREQUENCY RESPONSE:**  
±2 db 50-15,000 cycles.
- OUTPUT LEVEL:**  
+6 VU.
- SIZE:**  
44" long, 16½" wide, 10" high. Operating height: 31".
- WEIGHT:**  
68 lbs.
- POWER:**  
115 volts AC, 60 cycle.

### ORDERING INFORMATION

Portable audio console..... **KD-20A**

# MOBILE SOUND EFFECTS CONSOLE

Designed to produce sound effects for program production for TV and radio. Used by many of the world's leading radio and TV operations.

Six input circuits, two for microphones and four for pickups, feed into a program amplifier and a power amplifier. Each of these six channels has ladder attenuators with cue position at infinity. This cue output feeds into a split headphone arrangement. Four circuits are handled: (1) program cue, (2) sound effects cue, (3) sound effects out, and (4) director's cue. The two microphone channels are provided with PRE-4 plug-in preamplifiers, and the four pickup channels are provided with PRE-3 preamplifiers with high and low roll-off. In addition to individual equalization of each pickup, a master sound effects filter is provided, with complete high and low roll-off.

Cabinet is rigidly constructed of light metals to assure easy mobility on the silent rubber-tired wheels that may be locked in place for permanence. Front control panel hinges down for servicing. When not in use, the plexiglass copy stand pulls up and over the turntables and control panel.



### SPECIFICATIONS

- SIZE:**  
60" wide, 27½" deep, 48" high overall.
- POWER:**  
115 volts, 50/60 cycles, approximately 400 watts.
- WEIGHT PACKED:**  
1160 lbs. Cubage, 100.7.

### ORDERING INFORMATION

Sound effects console complete with tubes, less loudspeaker..... **CSE-9**  
100% spare tube complement..... **TK-155**



# 16-INCH PROFESSIONAL TRANSCRIPTION TURNTABLE

## Model CB-500

The Gates CB-500 is the most widely used 16 inch turntable in the broadcasting industry. Many thousands are in use worldwide.

Designed for continuous 24-hour commercial service, the CB-500 is ruggedly constructed to meet the strain of modern control room operation.

Time proven features include heavy machined aluminum platter, rubber shock mounted cast aluminum chassis, oilite hub bearings, self-centering neoprene idler wheel. "Monoball" self-aligning speed shift bearing and a simple speed selector mechanism.

Heart of the CB-500 design is a drive hub which is part of the machined turntable platter and about one-half the radius of a 45 RPM disc. The single idler wheel for all three speeds is floating and self-aligning. A 600 RPM hysteresis synchronous motor with 3-speed pulley engages the idler wheel to the inner hub. The combination of the lower speed motor, one-third that of other models, and the driver section (hub) being located inside the playing surface, reduced the rumble so remarkably that production line turntables now exceed earlier laboratory standards.

The CB-500 turntable will come up to speed at 33 $\frac{1}{3}$  RPM in  $\frac{1}{8}$  turn, and at 45 RPM in  $\frac{1}{6}$  turn. This is equivalent or superior to other recognized quality turntables which usually have higher rumble content.

Speed change is exact and functionally correct. All 3 speeds shift across a single indexed plate. A mercury type start-stop switch illuminates when on.

### SPECIFICATIONS

#### CHASSIS SIZE:

21 $\frac{1}{4}$ " x 21 $\frac{1}{4}$ " x 1 5/16".

#### MOTOR HANG BELOW BOTTOM OF CHASSIS:

4/8".

#### CONSTRUCTION:

Both platter and base of machined aluminum.

#### FINISH:

Gray enamel with escutcheon in black and turntable platter cover in heavy green felt.

#### PLATTER SIZE:

17".

#### STROBOSCOPE:

Inbuilt on platter for all 3 speeds.

#### CENTER SPINDLE:

Spring locking type, snaps up for 45 RPM hub, locks down for smaller spindle records.

#### CENTER BEARING:

1" diameter hardened steel rotates in Chrysler oilite bearing.



#### MOTOR:

Hysteresis synchronous, single phase, 600 RPM with 2 $\frac{1}{2}$  mfd. running capacitor and 40° C temperature rise.

#### CUE ALLOWANCE:

At 33 $\frac{1}{3}$  RPM,  $\frac{1}{8}$  turn.

At 45 RPM,  $\frac{1}{6}$  turn.

At 78 RPM,  $\frac{3}{4}$  turn.

#### NOISE OR RUMBLE:

At 33 $\frac{1}{3}$  RPM, rated -45 db.

At 45 RPM, rated -40 db.

At 78 RPM, rated -35 db.

#### WOW:

Rated 0.15% at 33 $\frac{1}{3}$  RPM, capable .08%.

#### FLUTTER:

Rated 0.07 at 33 $\frac{1}{3}$  RPM, capable .05%.

#### MOTOR START:

Rocker type mercury switch. Push front for "ON" and back for "OFF". Switch illuminates when on.

#### IDLER WHEEL:

Special shear action neoprene, self-aligning.

#### SPEED CHANGE:

To 33 $\frac{1}{3}$ , 45 or 78 RPM by single indexed level control.

#### POWER:

115 volts, 60 cycles, 35 watts. (50 cycle available)

#### SHIPPING WEIGHT & CUBAGE:

54 (net weight, 34 lbs.). 3 cu. ft.

### ORDERING INFORMATION

CB-500 Transcription turntable chassis only

for 115V, 60 cycles

M-5739

CB-500A Transcription turntable only

for 115V, 50 cycles

M-5739A

# 16-INCH PROFESSIONAL TRANSCRIPTION TURNTABLES

Models **CB-510, CB-525**



CB-510 complete operating transcription turntable includes CB-500 low noise chassis with synchronous motor, GRAY 208-S/G viscous damped pickup arm, twin flip-over 1 mil and 3 mil reluctance cartridge, 2-position variable equalizer to NAB/RIAA and high frequency roll off curves and M-6244 transistorized preamplifier with self-contained power supply. Output: 150 or 600 ohms adjustable from -22 dbm to -12 dbm, 12 MV input.



CB-510 turntable with platter removed showing the shift mechanism. The transistorized preamplifier bolts to the under side of the turntable chassis and has its own self-contained silicon power supply.



CB-525 and CB-525A turntable. This is the same as the CB-510 turntable but with the CAB-6 floor cabinet added. CAB-6 cabinet has adjustable leveling screws, full size rear door. Made of 5-ply seasoned birch, sealed and finished in gloss gray and black. Size: 21 $\frac{1}{4}$ " wide, 21 $\frac{1}{4}$ " deep, 29 $\frac{1}{2}$ " high plus 1" for leveling screws. For CB-500 chassis or CB-510 complete turntable.

## ORDERING INFORMATION

- CB-510 complete transcription turntable, including self-contained transistorized preamplifier, power supply, CB-500 chassis, 2-position equalizer, pickup arm and dual sapphire stylus for 115 v. 60 cycle ..... M-6053
- CB-510A complete transcription turntable, same as above but with dual diamond stylus ..... M-6053A
- CB-525 complete transcription turntable in cabinet, consisting of Model CB-510 above, mounted in CAB-6 cabinet ..... M-5828
- CB-525A complete transcription turntable in cabinet, consisting of Model CB-510A above, mounted in CAB-6 cabinet ..... M-5828A
- CAB-6 cabinet only for CB-500 chassis ..... M-5269
- Step-down transformer, primary 230V, 50/60 cycles, secondary 115V ..... M-5830

### THREE SPEED OPERATION

◀ Shift speeds to 78, 45 or 33 $\frac{1}{3}$  RPM by simply moving shift lever to the desired index point—then touch the switch to either start or stop. Complete one-hand operation leaves the other hand free for cueing or control boards.

# 12-INCH PROFESSIONAL TRANSCRIPTION TURNTABLES

## Models CB-77, CB-88, CB-880

Here are professional 12-inch transcription turntables, built identically to the companion 16-inch models. In the new CB-77 chassis will be found the same inner hub drive system, the same speed change system, the same rocker arm, illuminated off-on switch . . . the only difference is a reduced size, affording broadcasters a more compact turntable arrangement in today's busy control room.



**MODEL CB-77:** Chassis only, ready to attach pickup arm of your choice. For 33 1/3, 45 and 78 RPM with fast pickup-to-speed and low -45 db rumble at 33 1/3 and 45 RPM. Incorporates hysteresis synchronous motor.



**MODEL CB-88:** Complete ready to operate 12" turntable assembly. Includes CB-77 12" chassis, M-6244 transistor preamplifier, dual viscous damped Gray arm, twin flip-over 1 mil. and 2 1/2 mil. reluctance cartridge with your choice of sapphire or diamond styli, 2-position equalizer to NAB-RIAA and high frequency roll off curves and self-contained power supply (part of preamplifier).

**MODEL CB-880:** This model consists of the CB-88 complete turntable mounted in the CAB-8 single chassis cabinet.

### SPECIFICATIONS MODEL CB-77

**CHASSIS SIZE:**

16" x 16" x 1 5/16".

**MOTOR HANG BELOW BOTTOM OF CHASSIS:**

5 3/4".

**CONSTRUCTION:**

Both platter and base of machined aluminum.



**MODEL CAB-8 CABINET:** Designed to house the CB-77 chassis or CB-88 complete turntables. 16 1/8" wide, 16 1/8" deep and 30" high with leveling screws. Over-all maximum height with chassis mounted is 32 3/8". Built of cabinet maker's birch with corner supports of steel and finished in two-tone gray and black. Back door removable for servicing.

**FINISH:**

Gray enamel with escutcheon in black and turntable platter cover in heavy green felt.

**PLATTER SIZE:**

13 3/8".

**STROBOSCOPE:**

Inbuilt on platter for all 3 speeds.

**CENTER SPINDLE:**

Spring locking type, snaps up for 45 RPM hub, locks down for smaller spindle records.

**CENTER BEARING:**

1" diameter hardened steel rotates in Chrysler oilite bearing.

**MOTOR:**

Hysteresis synchronous, single phase, 600 RPM with 2 mfd. running capacitor and 40° C temperature rise.

**CUE ALLOWANCE:**

At 33 1/3 RPM, 1/8 turn.

At 45 RPM, 1/6 turn.

At 78 RPM, 3/4 turn.

**NOISE OR RUMBLE:**

At 33 1/3 RPM, rated -45 db., at 45 RPM, rated -45 db., at 78 RPM, rated -35 db.

**WOW:**

.15% maximum, capable .08%.

**FLUTTER:**

.07% maximum, capable .05%.

**MOTOR START:**

Rocker type mercury switch. Push front for "ON" and back for "OFF". Switch illuminates when on.

**IDLER WHEEL:**

Special shear action neoprene, self-aligning.

**SPEED CHANGE:**

To 33 1/3, 45 or 78 RPM by single indexed level control.

**POWER:**

105-125 volts, 60 cycles, 35 watts, (50 cycle model available, see below).

**SHIPPING WEIGHT:**

40 lbs. (net weight, 30 lbs.).

(See Ordering Information next page)



## ORDERING INFORMATION 12-INCH TURNTABLES

- 12-inch transcription turntable chassis only, 60 cycles ..... CB-77
  - 12-in transcription turntable chassis only, 50 cycles ..... CB-77A
  - Complete 12-inch transcription turntable including self-contained preamplifier, power supply, CB-77 chassis, 2-position equalizer, pickup arm and dual sapphire stylus ..... CB-88
  - Complete transcription turntable, same as above but with diamond stylus ..... CB-88A
  - Complete 12-inch transcription turntable in cabinet, consisting of Model CB-88 above, mounted in single chassis floor cabinet ..... CB-880
  - Complete transcription turntable in cabinet, consisting of Model CB-88A above, mounted in single chassis floor cabinet ..... CB-880A
- (All with hysteresis synchronous motor.)

## STEREO TURNTABLE PACKAGE MODEL M-6143

The new Gates M-6143 Stereo Turntable Package incorporates the advanced features necessary for the exacting process of stereo broadcasting. See complete package breakdown under Ordering Information.



## ORDERING INFORMATION

- Complete Stereo Turntable Package, including the CB-77 Chassis, M-6169 Transistor Stereo Preamplifier, Gray 212-TN Viscous Damped Arm, VR-1000-7 Stereo Pick-Up Cartridge with Diamond Stylus, mounted on a CAB-8 Cabinet ..... M-6143

## ACCESSORIES

### Gray 208-S, 208-S/G Viscous-Damped Tone Arm



Gray's new professional stereo tone arm is available in two models that are identical in performance. The model 208-S comes with a slide and modular weights for mounting single play stereo or monophonic cartridges.

The model 208-S/G has a special slot cut into the front of the tone arm to clear the stem of a G.E. turn-around cartridge allowing plug-in operation, and comes with specific hardware for this application. 16" tables only.

Gray viscous-damped arm ..... Model 208-S

Gray viscous-damped arm for turn-around cartridge ..... Model 208-S/G



### Gray Arm with Dual Viscous-Damping

This new Gray micro-balanced tone arm has sealed viscous-damping on both vertical and horizontal pivots for better tracking and lower resonance. It is completely statically balanced around the vertical pivot, providing maximum tracking stability. Designed for records up to 12 inches in diameter. Stylus force adjustable from zero to 15 grams, thus eliminating cartridge weights. Can be used with all popular cartridges. Use with 12" turntables only, such as CB-77.

Gray viscous-damped arm ..... Model 212-TN



### Gray Equalizer

Four-position equalizer for use with any low impedance pick-up cartridge and provides these curves: (1) Flat, (2) Intermediate, (3) Standard, (4) Roll off. Output impedance 150/250 ohms. Supplied as illustrated with etched dial plate and knob. Used with low impedance cartridges only.

Transcription Pickup Equalizer ..... Model 602-C

# TURNTABLE PREAMPLIFIERS

## MONOPHONIC TRANSISTOR EQUALIZED TURNTABLE PREAMPLIFIER — MODEL M-6244



A single channel monophonic preamplifier designed for use in broadcasting, recording, and general sound requirements where low distortion and exacting frequency response characteristics are demanded. Features self-contained power supply and transformer output.

### SPECIFICATIONS M-6244

**OUTPUT:**  
Adjustable from -22 dbm to -12 dbm, with 12 MV input.

**RESPONSE:**  
Within  $\pm 1$  db of RIAA/NAB standard curve. Additional high frequency roll off filter position provided.

**DISTORTION:**  
Less than 0.5% at normal levels (-22 to -12 dbm out).  
Less than 1.0% at 10 db overload (above 12 MV input).

**NOISE:**  
58 db or lower, below -12 dbm output (with 12 MV input).

**LOAD IMPEDANCE:**  
600 ohms or 150 ohms balanced or unbalanced.

**MAXIMUM OPERATING AMBIENT TEMP.:**  
+60°C (+140°F).

**POWER:**  
105/125 volts, 50/60 cps 1 watt.

**TRANSISTORS:**  
2—2N1414, 1—1N725, 1—X5A2.

**MOUNTING:**  
Two holes for mounting to Gates Turntable or inside of any cabinet. May be mounted in any position.

**SIZE:**  
2 9/16" wide, 8 5/8" long, 2 7/8" high.

**WEIGHT AND CUBAGE:**  
1 lb. 2 oz.; 0.9 cu. ft. domestic packed.

### ORDERING INFORMATION

Monophonic Transistor Equalizer Turntable Preamplifier ..... M-6244

### SPECIFICATIONS M-6169

**GAIN:**  
45 db,  $\pm 1$  db at 1 Kc, adjustable with Gain Control.

**RESPONSE:**  
To follow RIAA/NAB Curve  $\pm 1$  db or better.

**DISTORTION:**  
0.5% or lower, 30 to 15,000 cps at 0 dbm out.

**NOISE:**  
60 db or lower from -63 dbm input at 30 cycles (-123 dbm equivalent input noise). Capable 70 down (30 cps used because it is maximum gain frequency of amplifier).

**CROSSTALK:**  
Below noise level at all frequencies.

**SOURCE IMPEDANCE:**  
47K ohms,  $\pm 5\%$  unbalanced.

**LOAD IMPEDANCE:**  
600 ohms or 150 ohms balanced.

**MAXIMUM OUTPUT LEVEL:**  
0 dbm.

**MAXIMUM OPERATING AMBIENT TEMPERATURE:**  
55°C (131°F).

**POWER:**  
110/117/125 volts, 60 cps at 1 watt.

**TRANSISTORS:**  
4—2N1414, 4—2N422, 2—N2069

**MOUNTING:**  
Four holes for mounting. Can be mounted in any position.

## Stereophonic Transistor Equalized Turntable Preamplifier Model M-6169

Designed for use with Stereo turntables, the M-6169 is a fully shielded, four stage unit with self-contained power supply. The input load impedance of 47,000 ohms makes it possible to use the preamplifier with virtually all magnetic stereo and monophonic cartridges. Transformer output provides taps for 150 or 600 ohms and may be used balanced or unbalanced.



**SIZE:**  
9 1/2" x 5 1/8" x 3 1/2".

**WEIGHT AND CUBAGE:**  
3 3/4 lbs.; 1 cu. ft. domestic packed.

### ORDERING INFORMATION

Stereophonic Transistor Equalized Turntable Preamplifier ..... M-6169

## GE TYPE VR-II PICKUP CARTRIDGES

High Impedance VR-II Triple Play (turnover cartridge)	High Impedance Single Stylus VR-II	Low Impedance VR-II Triple Play (turnover cartridge)	Low Impedance VR-II Single Stylus
Sapphire .001" and sapphire .003" ..... 4G050	Sapphire .003" ..... 4G-040 Sapphire .001" ..... 4G-041	Sapphire .001" and sapphire .0025" ..... 4GD-015025	Diamond .001" ..... 4GS-01D Diamond .0025" ..... 4GS-02D
Diamond .001" and sapphire .003" ..... 4G052	Diamond .001" ..... 4G-061 Diamond .003" ..... 4G-063	Diamond .001" and sapphire .0025" ..... 4GD-01D025	Sapphire .001" ..... 4GS-01S Sapphire .0025" ..... 4GS-02S
Diamond .001" and diamond .003" ..... 4G053		Diamond .001" and diamond .0025" ..... 4GD-01D02D	

Response 20-20,000 cycles with output of 12 MV at 7 CM/Sec. Tracking pressure only 4 grams. Has replaceable clip in stylus. Use high impedance type with

Gates M-6244 equalized preamplifier and low impedance type with Gates M-5530 preamplifier and Gray 602C Equalizer.

### Replacement Styli for VR-II

Sapphire .001" ..... 4G-01S	Diamond .001" ..... 4G-01D
Sapphire .0025" ..... 4G-02S	Diamond .0025" ..... 4G-02D
Sapphire .003" ..... 4G-03S	Diamond .003" ..... 4G-03D

FOR STEREO: Cartridge with .0007" diamond stylus ..... VR1000-7  
MISCELLANEOUS: Replacement parts kit for VR-II cartridges RKP-009B

Replacement stylus for VR-1000-7 (diamond) ..... DR-7D



## CONTROL DESKS



**CB-4 HORSESHOE DESK** — The CB-4 desk provides an attractive and functional control room facility. Turntables are on each side of the operator at the correct arm's length for relaxed operation. Right and left wings are designed with enough width to hold 19

inches of rack panel equipment or may be used for tape and disc storage.

Most types of turntables and all types of speech input consoles may be used with this desk.

### SPECIFICATIONS

#### CONSTRUCTION:

Top of seasoned 7-ply selected birch covered with double thick black linoleum. Use of wood is for best turntable performance as well as appearance. Top edge is banded with a chrome style band fitting flush and is secured to two end wings having inside dimension of 22 $\frac{1}{2}$ " wide, 25" high and 45" deep. Each wing has a removable rear door and hinged front door. Wings are of seasoned plywood (selected birch) and will not warp or check.

#### FINISH:

Medium gray smooth lacquer. Top is black. Trim is chrome.

#### SIZE:

Height 29", Width 84", Depth 48".

#### WEIGHT:

Packed, 390 lbs.

#### CUBAGE:

120.

### ORDERING INFORMATION

Desk without cutouts .....	CB-4
Desk with cutouts for CB-500 — 16" turntables .....	CB-4-500
Desk with two CB-510A turntables, including 2 M-6244 monophonic transistor preamplifiers .....	CB-4-510A
Desk with cutout for 2 CB-77 — 12" turntables .....	CB-4-77
Desk with two CB-88A turntables includes 2 M-6244 monophonic transistor preamplifiers .....	CB-4-88A

CB-4 desks may be used with any Gates Console. Photo shows CB-4 with Dualux speech input system. Select desk combination of your choice and add console price for total selling cost. All CB-4 desks include basic AC wiring for two turntable packages.



## CUSTOM-BUILT AUDIO DESKS

Custom-built desks are available to suit any control room specification. Write Gates' Audio Products Manager for details and cost.

# CARTRITAPE II

## Monaural/Stereo Professional Cartridge Tape System

### For 1, 2 or 3 Cue Tone Operation

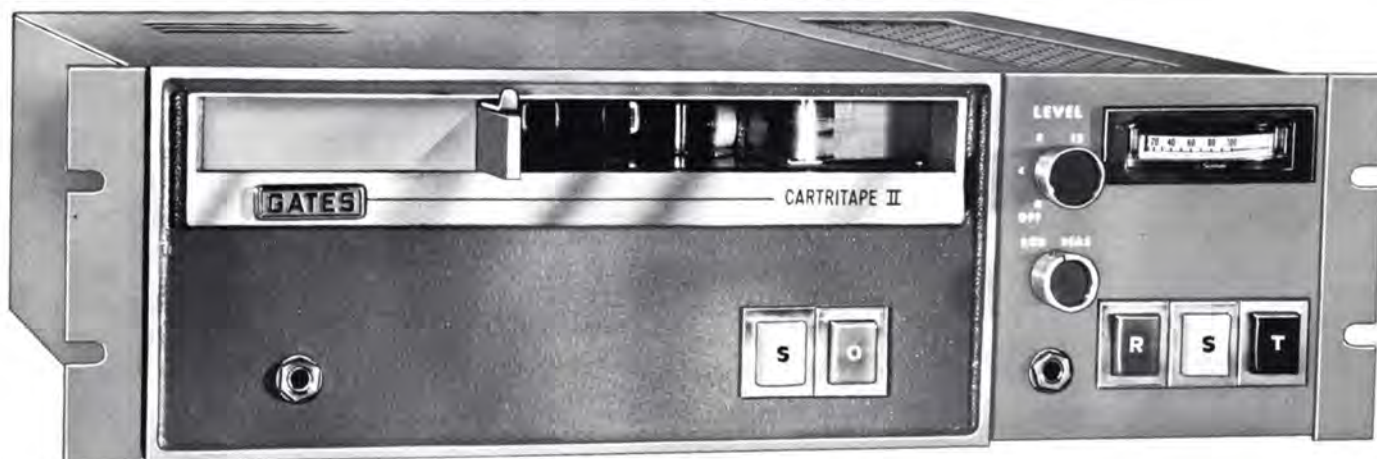

Figure 1. Monaural record/playback unit with 19" rack adaptors.

Gates Cartritape II is an entirely new cartridge tape system designed for Monaural or Stereo operation and for 1, 2 or 3 cue tone automated programming.

**BASIC RECORD PLAYBACK SYSTEM:** The basic system, shown in figure 1, consists of modular playback and record units. These two units have a combined size of 17" wide, 5 1/4" high and 16 1/2" deep. Supplied standard with the basic system are adaptors for 19" rack mounting and rubber feet for desk mounting. Circuitry and receptacles for plug-in amplifiers for 1, 2 or 3 tone and stereo operation are provided. *It is worth noting that the basic system is single tone and the broadcaster is not forced to pay for more facilities than he actually needs.* Merely order the amplifiers needed. The system can be increased any time the user desires additional automated programming.

**PLAYBACK UNIT:** Modular plug-in construction and transistor circuitry are two major features of the Cartritape II playback unit. It is constructed with the plug-in cue tone amplifiers and program amplifiers on glass epoxy chassis assemblies with gold plated connectors. The receptacles for a full complement of amplifiers (3 tone, stereo) are installed and wired into the basic unit making conversion of the system very simple. Plug-in relays are also utilized.

A new, exclusive, three position index assembly customizes the playback unit to any of the three cartridge sizes. This is accomplished with a sliding mechanism which automatically locks into the position selected. The motor deck plate is wear resistant, nonmagnetic stainless steel for absolute rigidity and is an aid to quick cartridge insertions. The non-magnetic feature contributes greatly to the low signal-to-noise ratio specification of Cartritape II. The motor of Cartritape II is of the synchronous type.

All of the inherent beneficial characteristics of transistors such as low heat, low power requirements (1.5 watts powers a full complement of 5 plug-in amplifiers), low

noise, long life, small size and reduced electrical maintenance are found in the Cartritape II playback unit. In addition, transistor circuits by nature operate at low impedance which makes them less susceptible to hum, RF and switching transients.

**RECORD UNIT:** The compact modular record unit of Cartritape II plugs into the side of a playback unit to provide complete professional recording versatility. Operation of Cartritape II is simple and efficient with new, quiet, touch control switches which show the operating status at a glance.

Circuitry in Gates Cartritape II is designed to accommodate 1, 2 or 3 cue tone operation in monaural or stereo, depending upon the amplifiers ordered. As most broadcasters still utilize and desire one tone monaural operation, the Cartritape II *basic* unit is designed for that purpose. With the simple addition of inexpensive plug-in amplifiers, the system can be extended to 2 or 3 tones.

In the one tone mode of operation, a 1 KC tone is applied to the tape, automatically, when the play/start switch is touched. During playback, the tape runs until it again reaches this tone, and then stops.



Playback Unit



## CARTRITAPE II PROFESSIONAL CARTRIDGE TAPE SYSTEM

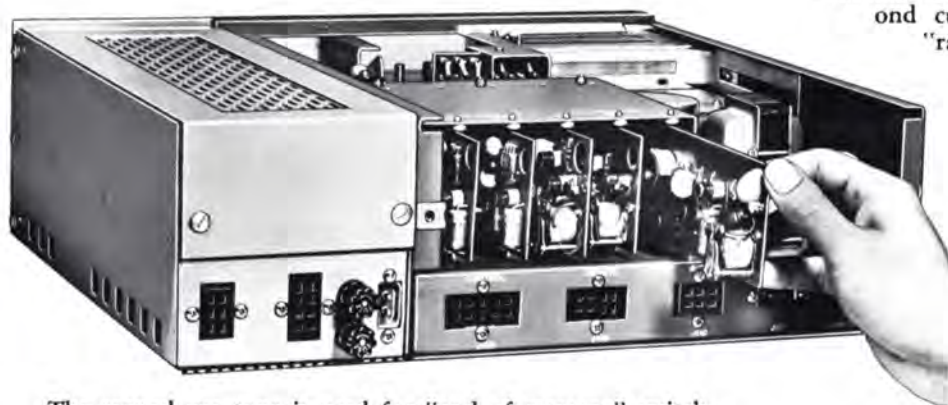

older systems. (b) "End of message" switching is supplied automatically on each cartridge by the 200 cycle second cue tone. (c) The third tone is a 5 KC "random" tone and may be recorded on the tape as many times and wherever necessary for programming effect. *It should also be noted that Cartritape II may be used as a two-tone system utilizing the plug-in 5 KC "random" and 1 KC "stop" amplifiers.*

**REMOTE CONTROL:** In Cartritape II, remote control circuitry is included in the record and playback units. It is only necessary to purchase the inexpensive remote unit (see photo) and plug it into the space provided.

The second cue tone is used for "end of message" switching and will automatically start another machine with its 200 cycle tone. This tone is automatically applied when the record/stop switch is touched at the end of the recorded message. The tape does not stop when the 200 cycle tone is reached, but continues to the 1 KC stop tone—and is again ready for instant programming.

The Cartritape II 2 tone system offers these advantages: (a) The first cue tone is the standard 1 KC tone used in nearly all older systems and allows the two tone unit to be incorporated in mixed systems. (b) Packaged spots from a single sponsor and rotating introductions can still be recorded "end to end" for automatic rotation each time they are played. (c) It is possible to program an entire station break automatically with the use of several two tone machines by just starting the first machine in the sequence. (d) Placing only one message on a cartridge allows maximum flexibility in intermixing. This flexibility is further enhanced by the use of the second cue tone.

By adding the third cue tone plug-in amplifier, both "end of message" and "random" switching are obtained. The 5 KC "random" cue tone is used for such things as TV slides and projectors, permitting any number of impulses to be placed at any point desired during the message.

With a full complement of cue tones the Gates Cartritape II system provides truly automatic operation. A typical station break may use any number of cartridges and display many slides. Previously, with systems limited to two tones, slide changing was possible, however, there was no provision for "end of message" switching. This necessitated the manual starting of each cartridge in sequence in order to complete the break. With the three tone system, slides are displayed as called for by the 5 KC "random" cue tone and the 200 cycle "end-of-message" switching starts the next machine.

The Cartritape II 3 tone system offers these advantages: (a) It provides the standard 1 KC stop tone recorded at the beginning of the message, as used on nearly all

**AUTOMATIC AUDIO SWITCHING UNIT:** An automatic switcher is also available which permits up to four playback units to be fed into one console input. With this addition to the system it is not necessary to manually switch the audio each time a unit is started.

**SEPARATE HEADS:** Separate recorder/playback heads are utilized eliminating head switching and the associated noise problems. Separate heads also provide playback monitoring from the tape during recording.



Cartritape II with stereo recorder



Automatic audio switching unit



Remote control unit

# CARTRITAPE II PROFESSIONAL CARTRIDGE TAPE SYSTEM

## SPECIFICATIONS

### SYSTEM RESPONSE:

$\pm 2$  db 40 to 12,000 cps.  $\pm 4$  db 30 to 15,000 cps.

### EQUALIZATION:

Standard NAB curve.

### HARMONIC DISTORTION:

Less than 2% at normal record level. (Limited by tape.)

### SIGNAL TO NOISE:

Monaural 2 track—55 db below 3% third harmonic distortion. Stereo 3 track—50 db below 3% third harmonic distortion.

### WOW AND FLUTTER:

0.2% RMS maximum.

### OUTPUT:

-15 dbm at 600 or 150 ohms balanced or unbalanced.

### SPEED:

7.5 ips.

### MONITORING:

Complete AB monitoring.

### RECORD AMPLIFIER INPUT:

150/600 ohms balanced at -20 dbm. 10,000 ohms bridging balanced across a +8 dbm line.

### CUE SIGNALS:

1000 cycle tone, standard cue.

200 cycle tone, end of message. (Optional Accessory)

5000 cycle tone, random. (Optional Accessory)

### POWER SUPPLY:

105-125 volt AC, 60 cycle. (50 cycle on special order)

### SIZE:

Playback unit: 5 $\frac{1}{4}$ " x 12" x 16 $\frac{1}{2}$ " deep.

Record unit: 5 $\frac{1}{4}$ " x 5" x 16 $\frac{1}{2}$ " deep.

NOTE: Record unit mounts to side of playback unit.

All models supplied with 19" rack adaptors and rubber feet for desk mounting.

### WEIGHT AND CUBAGE:

Record unit 12 lbs. Playback unit 21 lbs. Record/Playback unit, 2 cu. ft.

### AUTOMATIC AUDIO SWITCHER:

Input Capacity—4 playback units, monaural or stereo.

Size 17 $\frac{7}{8}$ " x 15" with 19" rack adaptors.

### REMOTE UNIT:

2 $\frac{3}{4}$ " high, 5 $\frac{3}{4}$ " wide, 5 $\frac{7}{8}$ " deep. 2 lbs.

### CONNECTIONS:

Quick disconnect plugs in 3 groups (Remote—Audio out—Control).

### FINISH:

Two-tone grey with brushed aluminum trim.

## ORDERING INFORMATION

Carritape II Playback Unit for Monaural, 1 Tone	M-6211
Carritape II Playback Unit for Monaural, 2 Tone	M-6211A
Carritape II Playback Unit for Monaural, 3 Tone	M-6211B
Carritape II Playback Unit for Stereo, 1 Tone	M-6212
Carritape II Playback Unit for Stereo, 2 Tone	M-6212A
Carritape II Playback Unit for Stereo, 3 Tone	M-6212B
Carritape II Record/Play Unit for Monaural, 1 Tone	M-6213
Carritape II Record/Play Unit for Monaural, 2 Tone	M-6213A
Carritape II Record/Play Unit for Monaural, 3 Tone	M-6213B
Carritape II Record/Play Unit for Stereo, 1 Tone	M-6214
Carritape II Record/Play Unit for Stereo, 2 Tone	M-6214A
Carritape II Record/Play Unit for Stereo, 3 Tone	M-6214B
Carritape II 200 cycle cue amplifier	M-6216A
Carritape II 5000 cycle cue amplifier	M-6216B
Carritape II Switcher, Monaural	M-6219
Carritape II Switcher, Stereo	M-6220
Carritape II Remote Unit	M-6221
Carritape II Cartridge Storage Rack	M-5986



# CARTRITAPE I

## Cartridge Tape System — Tube Version



Playback Unit

**M-5944B PLAYBACK:** The Cartritape I playback unit utilizes a thyatron tube to control the cue relay. This was used because of its extremely fast firing time. Cartridges are guided to the correct location automatically by a unique centering mechanism. The inserted cartridge starts the motor and lights the ready switch. All heads are especially selected and maintainable relay contacts are protected by a dust cover. Headphone jack is provided for playback monitoring. The output is muted by means of load substitution. Accessibility is complete—every part can be reached by removing bottom, top and side plates by unscrewing  $\frac{1}{4}$  turn fasteners. Remote control facilities and automatic switching unit also available.

### SPECIFICATIONS

#### FREQUENCY RESPONSE:

Standard NAB playback curve,  $\pm 2$  db, 50 to 12,000 CPS, at 7.5 IPS.

#### DISTORTION:

2% or less at normal recording level.

#### NOISE:

60 db or lower, below tape saturation level. 50 db or lower, below normal recording level.

#### WOW AND FLUTTER:

0.1% to 0.2% RMS.

#### TAPE SPEED:

$7\frac{1}{2}$ " per second.

#### EQUALIZATION:

Standard NAB playback equalization for 7.5 IPS.

#### PLAYING TIME:

1 second to 45 minutes in three basic cartridge sizes.

#### OUTPUT LEVEL:

-5 dbm at 500/600 ohms (factory connected), may be strapped for 150/250 ohm output.

#### CUEING ACCURACY:

Within 0.1 second. (as recorded)

#### START TIME:

0.1 second or less.

#### STOP TIME:

Essentially instantaneous.

#### POWER SOURCE:

115 volts, 60 CPS. (50 cycle model available on special order at slightly higher price).

#### POWER CONSUMPTION:

35 watts in the "Ready" position. 125 watts in the "Run" position.

#### TUBE COMPLEMENT:

(2) 12AX7, (1) EF86, (1) 2D21 and (1) 6X4.

#### HEIGHT:

7 inch Rack or custom mounting.

#### WIDTH:

19 inch Rack or 15 inch custom mounting.

#### DEPTH:

13 inches behind panel, excluding plugs.  $14\frac{3}{4}$  inches overall.

#### UNIVERSAL MOUNTING:

Standard 19 inch Rack, Custom 15 inch, Desk top.

#### WEIGHT:

Net 26 lbs., packed (domestic) 49 lbs., cubage 5.

#### AUXILIARY:

Remote Start, Remote Stop, Remote Record Start, Remote Record Stop, Remote Cue Interlock, Remote Record Interlock, Synchronized Start Circuit, Synchronized Cue Controlled Stop Circuit, Synchronized Automatic Sequential Start Circuit.



Record Unit

**M-5952 RECORDING AMPLIFIER:** The Cartritape I recorder is identical (except for cue tone) to any high quality recording amplifier. A gain control is located after the first stage to facilitate adjusting the recording level on the tape from a microphone input. The microphone input is 150 ohms at a level of -60 dbm.

Bridging input, balanced or unbalanced, is also provided. Two power supplies are used; one supplies power to the tubes—the other to the relays for actuation. The cue tone is recorded at the start of each recording, but it is possible to start and stop in the middle of a recording for dubbing without applying a new cue tone. Plug-in connectors are used for interwiring.

### SPECIFICATIONS

#### FREQUENCY RESPONSE:

Standard NAB recording curve,  $\pm 2$  db, 50 to 12,000 CPS at 7.5 IPS.

#### DISTORTION:

0.5% or less at normal recording level.

#### NOISE:

-120 dbm or lower, relative input noise with microphone level into matching input circuit.

#### EQUALIZATION:

Standard NAB recording curve for  $7\frac{1}{2}$  inches per second.

#### INPUT LEVEL:

-50 to -70 dbm at 30/50 or 150/250 ohms. -35 to +8 dbm at 10,000 ohms bridging. (both balanced or unbalanced)

#### CUEING ACCURACY:

Within 0.1 second. (as recorded)

#### POWER SOURCE:

115 volts, 50/60 cycles per second.

#### POWER CONSUMPTION:

25 watts.

#### TUBE COMPLEMENT:

(2) EF86, (1) 12AX7, (1) 12AU7 and (1) 6X4.

#### HEIGHT:

$5\frac{1}{4}$  inch Rack or custom mounting.

#### WIDTH:

19 inch Rack or 15 inch custom mounting. Universal mounting adaptors provided.

#### DEPTH:

11 inches behind panel, excluding plugs.  $12\frac{3}{4}$  inches overall.

#### WEIGHT:

Net 12 lbs., packed (domestic) 27 lbs., cubage 3.

### ORDERING INFORMATION

Cartritape I Playback Unit	M-5944
Recording Amplifier	M-5952
Automatic Switcher	M-5953
Remote Control Unit	M-5960

# AUTOMATIC TAPE CARTRIDGES



Model 1200



Model 600



Model 300

The automatic tape cartridges featured here are the continuous, self-contained, single reel type which operate on an endless loop principle. The tape is pulled from the center and after passing the playing or recording head is automatically rewound on the outside of the reel contained in the cartridge. This process goes on continuously until the machine is stopped or the cartridge is removed. Individual or multiple messages or musical selections, of varying length, will be repeated, limited only by the length of tape in the magazine. The tape is completely contained in the plastic magazine and is never touched by the operator. The cartridge is merely inserted and the Carritape is ready for instant operation.

## ADVANTAGES OF CARTRIDGE TAPE

- No threading—eliminates difficulty of threading tape on take-up reel; also prevents twists and kinks.
- No Rewinding—prevents excess slack and spillage—eliminates complicated handling.
- Eliminates tape breakage due to tension differences in supply and take-up reels; eliminates nicks, cuts and creases that cause tape breakage.
- Simplifies storage of cartridges which are designed to stack one on top of another in a self-storing unit.
- Minimizes damage from dust and grit thereby extending tape life.
- Ease of handling.

## STANDARD MAGAZINES

MODEL 300 SIZE:  
5 1/8" x 4" x 7/8"

MODEL 600 SIZE:  
7" x 6" x 7/8"

MODEL 1200 SIZE:  
8 3/4" x 7 1/2" x 7/8"

## ORDERING INFORMATION

### 300 SERIES

TIME	MODEL
Empty	F-300
40 Seconds	F-300A
70 Seconds	F-300B
100 Seconds	F-300C
3 1/2 Minutes	F-300D
5 1/2 Minutes	F-300E
10 1/2 Minutes	F-300G

### 600 SERIES

Empty	F-600
16 Minutes	F-600H

### 1200 SERIES

Empty	F-1200
31 Minutes	F-1200J

# "NITE-WATCH" AUTOMATIC PROGRAMMING SYSTEM

## 3 in 1 System



1



2



3

Nite-watch consists of three basic equipments supplied as a complete package: (1) production console, (2) tape control unit, and (3) the 100 record (up to 200 plays, both sides) 45 RPM automatic cueing transcription changer. Announcements are taped consecutively without intervening records. In the playback, announcements are automatically separated between record plays. Full editing sequence record selection and dubbing facilities are incorporated.

When not in use for automatic programming, this recorder may be used for standard record/playback to full NAB standards.

If desired, a simple switch control unit may be purchased as an optional accessory. In this way, the 100 record unit becomes fully automatic transcription equipment.

Operation of "Nite-watch" is by no means complicated. Actually, it is more simple than a control board operation. Continual programming up to as much as six hours is easily possible. The amount of automatic programming is at the discretion of the program director.

For complete information on the Gates "Nite-watch" system contact your local Gates sales engineer or the Quincy sales office.

### ORDERING INFORMATION

- "Nite-watch" complete, includes production unit cabinet model recorder/playback and changer unit, ready to operate ..... M-5671
- "Nite-watch" same as above but less cabinet for tape recorder and control amplifier (for your own rack cabinet) ... M-5628
- Recorder panel for use with tape recorder where use of M-5661 production console is not desired for straight tape recording ..... M-5664
- Control switch box for using M-5663 changer as remote operated transcription equipment..... M-5665

# TRANSISTOR AUDIO AMPLIFIERS

The new Gates line of transistor audio amplifiers represents an extraordinary achievement in highly advanced transistor engineering. These compact amplifiers are part of Gates' new exclusive *Solid Statesman* line of transistor products.

The *Solid Statesman* audio amplifier line includes a pre-amplifier, program amplifier, monitor amplifier, power supply, mounting trays, and a specially designed space-saving shelf assembly.

## SPECIAL FEATURES

- Generous heat sink design of the *Solid Statesman* amplifiers provides a 50% safety factor so that all amplifiers operate at a continuous sine wave at maximum ambient temperature levels and at maximum rated output levels.
- Automatic short circuit protection incorporated in the M-5702 power supply provides zero voltage until any short circuit is released, at which time operation resumes without damage to the power supply or transistors.
- All transistors are plug-in triple A industrial type which

Whether your audio amplifier needs are for new total system installations, expansion or revision of present systems, loudspeaker distribution, replacement in consoles, today's stereo FM, multi-track theatre reproducing systems or any other application in AM, FM, TV, recording studio or military installations . . . the *Solid Statesman* transistor audio amplifiers are ready and more than able to meet nearly every conceivable situation.

- eliminates any possibility of thermal damage during operation.
- All circuits are printed wiring on glass epoxy boards for uniformity, strength and reliability.
- Connectors of the plug-in audio amplifiers are gold plated for absolute contact. Floating type receptacle also assures positive, fast alignment.
- Negligible heat radiation eliminates the necessity for cooling large numbers of rack mounted amplifiers.

## GATES TRANSISTOR AUDIO AMPLIFIER CHARACTERISTICS

Type	Application	Maximum Gain DB	Maximum Input DBM	Maximum Output DBM	Source Impedance Ohms	Load Impedance Ohms	Type of Mounting
M-6028	Preamplifier Booster Amplifier	Matching 40 db	-22 dbm	+18 dbm	30/50 150/250 500/600 ohms	150/250 500/600 ohms	Plug-in (M-6030 tray required)
M-5700B	Program Amplifier Bridging Amplifier	Matching 70 db	-35 dbm	+24 dbm	150/250 500/600 ohms	150/250 500/600 ohms	Plug-in (M-6031 tray required)
M-5701B	Monitor Amplifier	Matching 90 db	-35 dbm	+39 dbm 8 watts	30/50 150/250 500/600 ohms	4/8/16 ohms	Plug-in (M-6032 tray required)
M-6108	Utility Monitor Amplifier	Matching 53 db Bridging 39 db	Matching -14 dbm Bridging 0 dbm	+39 dbm 8 watts	600-6000 ohms	4/8/16 ohms	Chassis

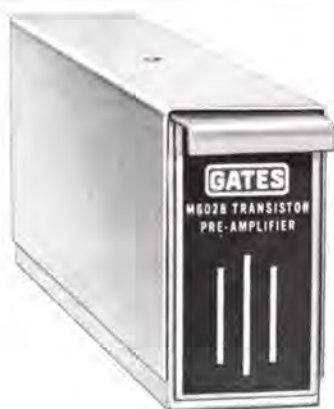

TRANSISTOR PLUG-IN PREAMPLIFIER M-6028

### SPECIFICATIONS\*

**GAIN:**  
40 db  $\pm$  1 db.

**RESPONSE:**  
 $\pm$ 0.5 db, 30 to 15,000 cps.

### HARMONIC DISTORTION:

Under 0.75% at 30 cps, under 0.5% from 50 to 15,000 cps at +18 dbm output.

### NOISE:

-122 dbm relative input noise.

### SIZE:

1 3/4" Wide, 3 1/8" High, 10 3/4" Long, 9 units to an M-6029 3 1/2" Shelf Assembly (19" panel).

### MOUNTING:

Gates M-6030 mounting tray is required.

### POWER REQUIREMENTS:

30V. DC at 30 ma. (0.9W.).

### TRANSISTORS:

1—2N422, 1—2N1183, 2—2N1414.

### SOURCE IMPEDANCE:

30/50 - 150/250 - 500/600 ohms (balanced or unbalanced).

### LOAD IMPEDANCE:

150/250 - 500/500 (balanced or unbalanced).

### CONNECTORS:

Gold plated Blue Ribbon Type 26-4100-16P and 26-4200-16S.

### FINISH:

Cadmium plated enclosure with black anodized escutcheon plate.

### WEIGHT:

3 1/2 lbs. net.

\*Manufacturer's Rating; Capable performance often in excess of these ratings.

## TRANSISTOR PLUG-IN PROGRAM AMPLIFIER M-5700B



### SPECIFICATIONS\*

**GAIN:**  
70 db, may be reduced as required with internal control.

**RESPONSE:**  
± 1 db from 30 to 15,000 cps.

**HARMONIC DISTORTION:**  
Under 0.75% at 30 cps, under 0.5% from 50 to 15,000 cps at +24 dbm output.

**NOISE:**  
- 115 dbm relative input noise, 65 db below - 50 dbm input.

**SIZE:**  
2 5/32" Wide, 3/8" High, 10 3/4" Long, 7 units to an M-6029, 3 1/2" Shelf Assembly (19" panel).

**MOUNTING:**  
Gates M-6031 mounting tray is required.

**POWER REQUIREMENTS:**  
30V. DC at 90 ma.

**TRANSISTORS:**  
5—2N1414, 1—2N1183, 1—2N422.

**SOURCE IMPEDANCE:**  
150/250 or 500/600 ohms (balanced or unbalanced).

**LOAD IMPEDANCE:**  
150/250 - 500/500 ohms (balanced or unbalanced).

**CONNECTORS:**  
Gold plated Blue Ribbon type 26-4100-16P and 26-4200-16S.

**FINISH:**  
Cadmium plated enclosure with black anodized escutcheon plate.

**WEIGHT:**  
4 1/4 lbs. net.

\*Manufacturer's Rating; Capable performance often in excess of these ratings.

## TRANSISTOR PLUG-IN MONITOR AMPLIFIER M-5701B SPECIFICATIONS\*

**GAIN:**  
90 db, may be reduced as required with internal control.

**RESPONSE:**  
± 1 db from 30 to 15,000 cps.

**HARMONIC DISTORTION:**  
Under 1% from 30 to 15,000 cps at +38 dbm (6 watts).  
Under 1% from 50 to 15,000 cps at +39 dbm (8 watts).

**INTERMODULATION DISTORTION:**  
Under 1% at +39 dbm equivalent sine wave power output, using 60 and 7000 KC, mixed 4:1.

**NOISE:**  
- 120 dbm relative input noise.

**SIZE:**  
4 1/8" Wide, 3/8" High, 12 3/4" Long, 4 units to an M-6029 3 1/2" Shelf Assembly (19" panel).

**MOUNTING:**  
Gates M-6032 mounting tray is required.

**POWER REQUIREMENTS:**  
110/117/125 volts, 50/60 cps, 18 watts.

**SELF-CONTAINED POWER SUPPLY.**

**TRANSISTORS:**  
1—2N422, 1—2N214, 2—2N553, 2—2N1183, 6—2N1414, 1—2N1225.

**SOURCE IMPEDANCE:**  
30/50, 150/250 or 500/600 ohms (balanced or unbalanced).



**LOAD IMPEDANCE:**  
8 ohms nominal (unbalanced), 4 or 16 ohm loads cause slight power loss only.

**CONNECTORS:**  
Gold plated Blue Ribbon type 26-4100-16P and 26-4200-16S.

**FINISH:**  
Cadmium plated cover, black wrinkle sides and black anodized escutcheon plate.

**WEIGHT:**  
8 1/2 lbs. net.

\*Manufacturer's Rating; Capable performance often in excess of these ratings.

## TRANSISTOR PLUG-IN POWER SUPPLY M-5702



### SPECIFICATIONS

**OUTPUT:**  
30V. DC at 400 ma. Maximum.

**INPUT:**  
110/117/125V., 50/60 cps, 18 watts with maximum load.

**NOISE:**  
0.1 MV(RMS) ripple or better.

**TRANSISTORS:**  
1—2N214, 2—2N1539, 2—2N1414, 1—2N1225.

**SIZE:**  
4 1/8" Wide, 3/8" High, 12 3/4" Long, 4 units to an M-6029, 3 1/2" Shelf Assembly (19" Panel).

**MOUNTING:**  
Gates M-6032 mounting tray is required.

**SUPPLIES POWER FOR:\***  
13—M-6028 Preamplifiers.  
or 4—M-5700B Program Amplifiers.  
or 7—M-6028 Preamplifiers plus  
2—M-5700B Program Amplifiers.  
or any combination not exceeding 400 ma. load current.

**CONNECTORS:**  
Gold plated Blue Ribbon Type 26-4100-16P and 26-4200-16S.

**FINISH:**  
Cadmium plated cover, black wrinkle sides and black anodized escutcheon plate.

**WEIGHT:**  
8 1/4 lbs. net.

\*As power supply is fully regulated, any lesser number of units may be used without voltage change.

## PANEL AND SHELF ASSEMBLY FOR TRANSISTOR PLUG-IN AMPLIFIERS



**PANEL AND SHELF ASSEMBLY M-6029**

### SPECIFICATIONS

Each Gates plug-in transistor amplifier and power supply requires its own mounting tray as follows:

- M-6030 Mounting Tray required for M-6028 Preamplifier.
- M-6031 Mounting Tray required for M-5700B Program Amplifier.
- M-6032 Mounting Tray required for M-5701B Monitor Amplifier and M-5702 Power Supply.



**MOUNTING TRAY**

Fast and foolproof connections are assured every time a Gates transistor plug-in amplifier is placed in its mounting tray. A floating type receptacle gives positive alignment and the steel "key pin" prevents any possible mix-up of amplifiers in the system.

- SIZE:** 3 1/2" High, 19" Wide, 14 1/2" Deep with hinged swinging front panel.
- HOLDS:** 9 M-6028 Preamplifiers or 7 M-5700B Program Amplifiers or 4 M-5701A Monitor Amplifiers or 4 M-5702 Power Supplies or combinations not exceeding 17" in width.
- For use with standard 19" rack cabinets. Panel swing clears standard cabinet trim strips (when installed).

## TRANSISTOR UTILITY MONITOR AMPLIFIER M-6108

### SPECIFICATIONS

- IMPEDANCES:**  
Transformer input. 600 ohms matching or 6000 ohms bridging.
- GAIN:**  
53 db at 600 ohm input. 39 db at 6000 ohm bridging input.
- RESPONSE:**  
20-20 cycles with  $\pm 1.0$  db.
- DISTORTION:**  
Below 1% from 30 - 15,000 cps at +38 dbm (6 watts).  
Below 1% from 50 - 15,000 cps at +39 dbm (8 watts average or 16 watts peak).
- NOISE:**  
85 dbm below rated +39 dbm output.
- POWER:**  
117 volts, 50/60 cycles, 18 watts.
- SIZE:**  
4 1/2" Wide, 8 1/2" Long, 3 1/2" High over-all.
- FINISH:**  
Light grey cover, flat black heat sink chassis.
- WEIGHT:**  
4 lbs. net.



- Specifications surpass maximum broadcast standards
- Will fit in nearly any speaker enclosure
- Keyhole mounting slots and non-scratch rubber feet
- Gain control and solid state power supply are self-contained
- Extremely low power requirements.

## ORDERING INFORMATION

Transistor Preamplifier	M-6028
Transistor Program amplifier	M-5700B
Transistor Monitor amplifier, with self-contained power supply	M-5701B
Transistor power supply (supplies power for (13) M-6028 or (4) M-5700B amplifiers)	M-5702
Mounting tray (for M-6028 preamplifier)	M-6030
Mounting tray (for M-5700B program amplifier)	M-6031
Mounting tray (for M-5702 power supply or M-5701B monitor amplifier)	M-6032
Shelf Assembly	M-6029
Transistor 8 watt Utility Monitor amplifier	M-6108



## PLUG-IN TUBE AMPLIFIERS

### PRE-4 PREAMPLIFIER



**USE:** Microphone, or booster amplifier. Size permits mounting in console or desk.

**GAIN:** 40 db  $\pm$  1 db.

**RESPONSE:**  $\pm$  2 db 30-15,000 cycles.

**DISTORTION:** 0.5% or less 50-15,000. 0.75% or less at 30 cycles at +8 dbm output.

**NOISE:** 90 db below +8 dbm output (-122 dbm equivalent input noise).

**LEVELS:**

Maximum input -32 dbm. Maximum output at above rated distortion, +8 dbm.

**IMPEDANCES:**

Source 30/50 and 150/250 ohms. Load 150/250 and 500/600 ohms.

**POWER:**

Requires 6.3 volts AC or 0.3 amperes and 275/310 volts DC at 6 MA. One PWR-3 Power Supply will operate up to 26 PRE-4 preamplifiers.

**TUBES:**

Two type EF86.

**MECHANICAL:**

Size 2 1/6" x 11 1/2" x 5 3/8" high overall. Mounts eight in one PAS-1 panel and shelf assembly.

### ORDERING INFORMATION

PRE-4 Preamplifier with Tubes .....	M-4174
100% Spare Tube Complement .....	TK-403
BA-20 Base and Receptacle .....	M-4618

### PGM-4 PROGRAM AMPLIFIER

**USE:** As high quality program or line amplifier where output up to +24 dbm at low distortion is desired.

**GAIN:** 65 db  $\pm$  1 db.

**RESPONSE:**  $\pm$  2 db 30-15,000 cycles.

**DISTORTION:** 0.5% 50-15,000 cycles. 0.75% or less at 30 cycles, at +24 dbm output.

**NOISE:** 79 db or better below +24 dbm output with volume control fully open. (-122 dbm equivalent input noise).

**LEVELS:** Maximum input +8 dbm. Maximum output +24 dbm.

**IMPEDANCES:** Input 150/250 and 500/600 ohms. Output 150/250, 500/600 ohms.

**POWER:** 6.3 volts AC at 1.05A and 300/330 volts DC at 37 MA. One PWR-3 Power Supply will operate up to 4 PRE-4 Amplifiers.

**TUBES:** Three 12AU7 and one EM86.



**CIRCUIT:**

Three stages with push-pull output. Feedback between second and third stages.

**MECHANICAL:**

Cold rolled steel chassis, die formed and heavily plated.

**WEIGHT:**

10 lbs.

**SIZE:**

4 1/8" x 11 1/2" x 6 5/8" high overall.

### ORDERING INFORMATION

PGM-4 Program amplifier with tubes .....	M-4176
BA-21 Base and receptacle .....	M-4619
100% spare tube complement .....	TK-400

### MON-4 MONITORING AMPLIFIER



**USE:** For loudspeaker distribution, recording and auxiliary program amplifiers. High gain allows use with bridging controls or other loss circuits. PWR-10 power supply also needed for MON-4 Amplifier.

**GAIN:** As straight amplifier, 103 db. When used with AT2 bridging control, 70 db.

**RESPONSE:**  $\pm$  2 db 30-15,000 cycles.

**DISTORTION:** 3% or less at +37 dbm with gain control fully open. (Equivalent input noise -120 to -124 db.)

**LEVELS:**

Maximum input -27 dbm. Maximum output +37 dbm.

**IMPEDANCES:**

Input 150/250 and 500/600 ohms. Output 500/600, 150/250, 16, 8 and 4 ohms.

**POWER:**

6.3 volts AC at 15A and 320/340 volts DC at 85 MA.

**TUBES:**

Two each EF86, 6AQ5 and one 12AU7.

**CIRCUIT:**

Four-stage with push-pull output, Tertiary winding feedback from secondary of output transformer to cathode of driver stage.

**MECHANICAL:**

Cold rolled steel chassis, die formed and heavily plated. Size: 4 1/8" x 11 1/2" x 6 5/8" high overall. One PWR-3 power supply, and one PWR-10 bias supply, will operate one or two MON-4 monitoring amplifiers.

### ORDERING INFORMATION

MON-4 Monitoring amplifier with tubes .....	M-4175
BA-21 Base and receptacle .....	M-4619
100% spare tube kit .....	TK-399

## PLUG-IN TUBE AMPLIFIER ACCESSORIES

### PWR-3 REGULATED POWER SUPPLY

**USE:**

An unusually well regulated power supply with very low ripple content. Where use with MON-4 monitoring amplifier, the PWR-10 bias supply should be ordered. Bias supply not required for preamplifiers or program amplifiers.

**CAPACITY:**

Will supply up to 26 PRE-4 preamplifiers, four PGM-4 program amplifier, two MON-4 monitoring amplifiers or any combination of the above.

**POWER:**

Supplies 6.3 volts AC at 8A, 310/350 volts DC at 0-160 MA. With PWR-10 bias unit added, supplies 15 volts at zero current. For 115 volts, 50/60 cycles, 230 volt design available on special order.

**INTERNAL IMPEDANCE:**

Negligible.

**RIPPLE CONTENT:**

**TUBES:**

Less than 0.002 volts or 0.0006% through entire voltage range. One each 5V4G, EF86, 6080 and two OA2.

**MECHANICAL:**

Cold rolled steel chassis, die formed and plated. Hum balance control on filament circuit and voltage output control on front.



Size 4 1/8" wide, 11 1/2" front to back, 6 3/8" high. Mounts four in a panel and shelf assembly.

#### ORDERING INFORMATION

PWR-3 Power supply with tubes .....	M-5000A
BA-21 Base and receptacle .....	M-4619
100% spare tube kit .....	TK-431

#### BASE AND RECEPTACLE



Two bases accommodate all tube type plug-in units. Model BA-20 is for the PRE-4 preamplifier. BA-21 is for the PGM-4 program amplifier, the MON-4 monitoring amplifier and PWR-3 regulated power supply. Mounts on bottom of PAS-1 panel and shelf assembly. Where other mounting desired may be secured to any panel, base of desk, or wood cabinet. Supplied with receptacle.

#### ORDERING INFORMATION

BA-20 Base and Receptacle .....	M-4618
BA-21 Base and Receptacle .....	M-4619

#### PANEL AND SHELF ASSEMBLY



Used for rack or multiple mounting of plug-in units. Requires only 7" x 19" rack space. Front is ventilated by top half being perforated and is instantly removable to allow removing amplifiers from the front, or making gain adjustments. The BA-20 or BA-21 bases with receptacle, listed below, fasten to the bottom of the panel and shelf assembly. Depth is 13 3/8". Finish medium gloss gray. Weight 10 lbs.

#### ORDERING INFORMATION

PAS-1 Panel and Shelf .....	M-3982
-----------------------------	--------

#### PWR-10 BIAS SUPPLY



Plugs into socket provided on PWR-3 regulated supply to provide bias voltage to one or two

MON-4 monitoring amplifiers. Not required for preamplifiers or program amplifiers. Where bias supply is used this does not restrict power supply for use with monitoring amplifiers only. Amplifiers may be mixed as desired.

#### ORDERING INFORMATION

Bias supply .....	PWR-10
-------------------	--------

#### BRIDGING CONTROLS

For use with Gates tube type plug-in amplifiers where bridging input is preferred over direct impedance matching. Two high quality carbon controls in tandem, balanced to ground, make up each control. Mounting is external to amplifier.

#### ORDERING INFORMATION

AT <sub>1</sub> Control, 10,000 ohms to 150 ohms .....	M-4340
AT <sub>2</sub> Control, 10,000 ohms to 600 ohms .....	M-3722
AT <sub>3</sub> Control, 20,000 ohms to 150 ohms .....	M-4341
AT <sub>4</sub> Control, 20,000 ohms to 600 ohms .....	M-4041



# DUAL PEAK LIMITING AMPLIFIER

Model M-6144

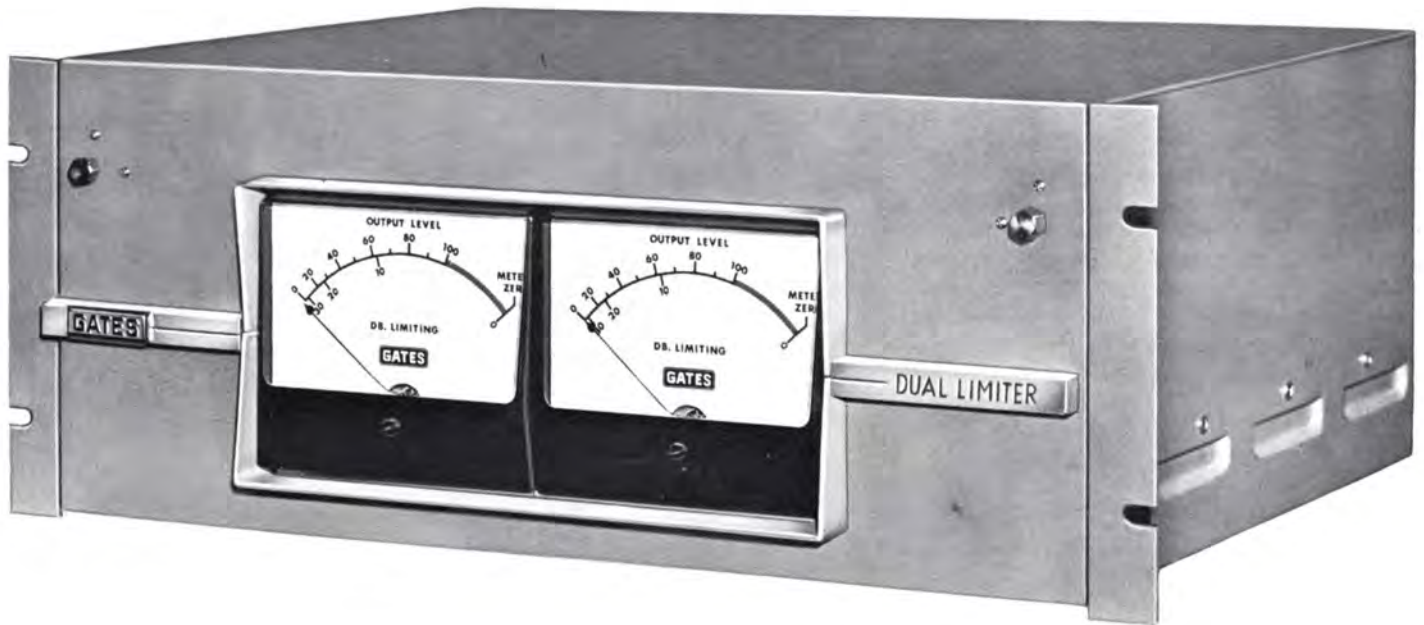

FM stereo broadcasting has created the need for specialized audio equipment. Of major importance is the stereo limiting amplifier. The content of a stereo signal is such that two individual single channel limiting amplifiers will not provide best service. The difference in level between stereo channels may cause one channel to limit heavily while the other is not limiting at all. This will cause unbalance between channels and serious loss of stereo effect.

This unbalancing effect is overcome with the Gates M-6144 stereo limiting amplifier as the highest signal level of either stereo channel determines the total amount of peak limitation. Likewise, the stereo signal balance is not altered and yet the function of the limiter is fully utilized. Amplifiers used for stereo must have identical characteristics because differences in response, distortion and phase will cause undesirable differences in the left and right stereo channels. The identical amplifiers, both as to electrical and design content, in the Gates dual limiter effectively solves this problem.

Though designed for effective stereo operation, the dual limiting amplifier is equally adaptable to separate dual transmitter operation such as AM and FM. The common solid state power supply operates both limiting amplifiers. Complete separate balancing controls are built-in to assure uniform characteristics.

No tubes are used in the power supply and even direct current is applied to the low level filament circuits. A power transistor is connected in a "capacitor multiplier" circuit to essentially eliminate ripple on the low level filaments. This contributes greatly to the outstanding low noise level of  $-70$  db.

All operating controls are on the front, located behind a drop-down front panel. A selector switch for each channel permits the meter to read (a) decibels of limitation, (b) output level, and (c) first stage balance indication. Attenuators are provided for controlling both input and output level. If desired, the dual limiter may be connected between the telephone line input and the transmitter input, a feature usually not possible with most limiting amplifiers. An added front panel switch provides instant changeover from stereo to separate amplifier operation.



## DUAL PEAK LIMITING AMPLIFIER

Each amplifier of the M-6144 dual limiter has four audio stages consisting of a push-pull variable gain stage, a voltage amplifier, phase inverter and push-pull output stage. A very fast attack time of up to 600 microseconds is accomplished through new Gates advanced circuitry. The signal to thump ratio is extremely low by reason of dynamic and static balancing controls in the first audio stage. Intermodulation distortion is less than 1.5% up to 20 decibels of limiting while channel separation/crosstalk is substantially below noise level at all frequencies.

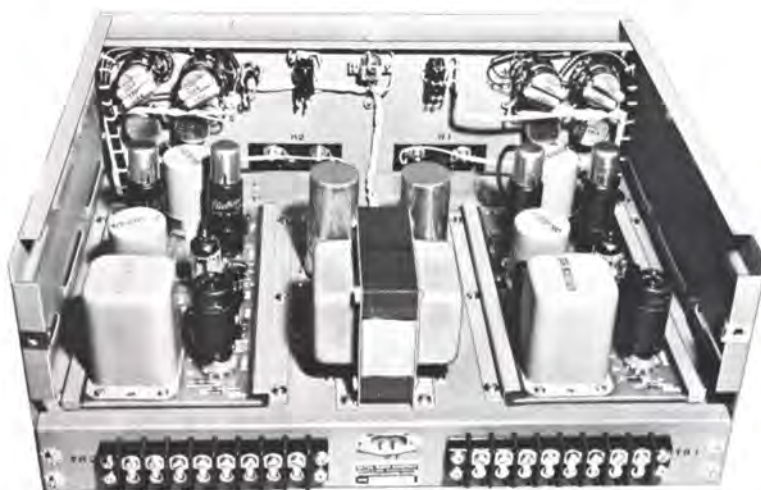

### SPECIFICATIONS

**GAIN:**

63 db  $\pm$ 2 db.

**FREQUENCY RESPONSE:**

$\pm$ 1 db, 30-15,000 cps.

**HARMONIC DISTORTION:**

Less than 1%; 30-15,000 cps at 10 db limiting, 1%;  
30 to 15,000 cps up to 25 db limiting.

**INTERMODULATION DISTORTION (60/7000 — 4:1):**

Less than 1% below threshold of limiting. Less than  
1.5% up to 20 db limiting.

**NOISE LEVEL:**

—70 db signal/noise ratio at +24 dbm output.

**COMPRESSION ATTACK TIME:**

Up to 600 microseconds.

**SIGNAL-TO-THUMP RATIO:**

—35 db typical up to 25 db of limiting. Rated —20  
db, minimum.

**THRESHOLD OF LIMITING:**

Input —45 dbm, matching, with maximum gain.  
Output +24 dbm, feeding into the 6 db isolation pad.

**CHANNEL SEPARATION OR CROSSTALK:**

—70 db or better.

**SOURCE IMPEDANCE:**

600 ohms.

**LOAD IMPEDANCE:**

600 ohms.

**MAXIMUM INPUT LEVEL:**

0 dbm MATCHING, +24 dbm bridging.

**POWER REQUIREMENTS:**

60 watts, 115 volts, 50/60 cps.

**TUBE COMPLEMENT:**

(4) 6K7  
(2) 12AX7  
(2) 12BH7  
(2) OB2

**DIODE TRANSISTOR COMPLEMENT:**

(4) X5A6  
(4) X5A2  
(4) GO-1  
(1) 2N1539 or 2N554

**SIZE:**

Width 19" x 7" (panel)  
Depth 16"

**WEIGHT:**

38 lbs. net—50 lbs. packed.

**CUBAGE:**

2.6 cu. ft.

**FINISH:**

Medium gray with brushed aluminum trim.

### ORDERING INFORMATION

Dual Peak Limiting Amplifier ..... M-6144  
Spare Tube Kit ..... TK-420

# PEAK LIMITING AMPLIFIER

Model SA-39B



Recognized engineering design, emphasizing serviceability as well as top performance, has made the Gates SA-39B the most trusted and accepted limiting amplifier in broadcasting.

This extremely reliable unit produces fast limiting performance and very low distortion at high degrees of limiting action, which automatically prevents overmodulation. This permits higher volume settings on the control board and more audio signal to primary and fringe areas. Even though you may now own an older limiter, the SA-39B limiting amplifier is so much faster, lower in distortion and wider in response, that signal improvement is quickly noticeable.

The very fast attack time, essentially instantaneous, is associated with six switch selectable release times. In this

manner the engineer may adopt the mode of operation best suited for him. Limiting action is by full wave rectification of the output voltage with the resultant negative direct current fed to the second control grid of the pushpull input stage. As the output voltage increases, the grid becomes more negative, lowering the gain of the amplifier. Although action is extremely fast, no added distortion is induced at compression levels as high as 20 db.

The circuit design provides separate input and output level controls and three pushpull stages. An electronically regulated power supply incorporates 6X5, 6SJ7 and 6L6G tubes with a 5V4G cathode type rectifier. The regulated power supply assures limiter calibration over wide ranges of line voltage. A wide scale 4" meter is calibrated in decibels of compression for direct reading.

## SA-39B LIMITING AMPLIFIER

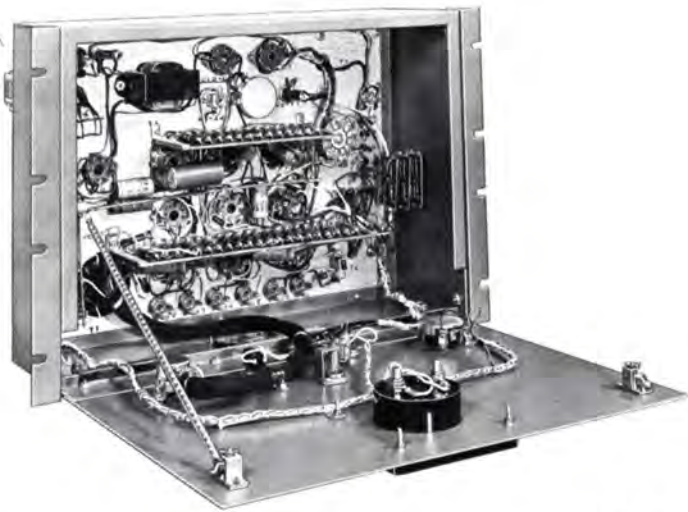

### SPECIFICATIONS

**INPUT IMPEDANCE:**  
500/600, 150/250, 30/50 ohms.

**OUTPUT IMPEDANCE:**  
500/600 ohms.

**INPUT LEVEL:**  
-20 to +20 db (adjustable by attenuator).

**OUTPUT LEVEL:**  
+19 dbm or less (adjustable by attenuator).

**MAXIMUM GAIN:**  
50 db.

**AUDIO RESPONSE:**  
30-15,000 cycles at +1½ db.

**AUDIO DISTORTION:**  
1½% or less 30-15,000 cycles at 15 db compression.

**NOISE:**  
65 db or better below any adjustable output level.

**ATTACK TIME:**  
Essentially instantaneous.

**RELEASE TIME:**  
Six positions from 0.2 to 1.2 seconds.

**SIZE:**  
19" wide, 14" high, 9½" deep.

**FINISH:**  
Medium gloss gray.

**DC REGULATION:**  
±5 volts of main plate supply.

**POWER INPUT:**  
115 volts, 50/60 cycles, 90 watts.

**TUBES:**  
(2) 1612, (2) 6V6GT, (3) 6SJ7, and one each 6H6, 6X5GT, 6L6G and 5V4G.

**WEIGHTS:**  
Net 36 lbs. Domestic packed 74 lbs. Export packed 96 lbs. Cubage 9½".

### ORDERING INFORMATION

Model SA-39B Limiter with tubes ..... M-3529B  
Spare 100% tube kit for above ..... TK-150

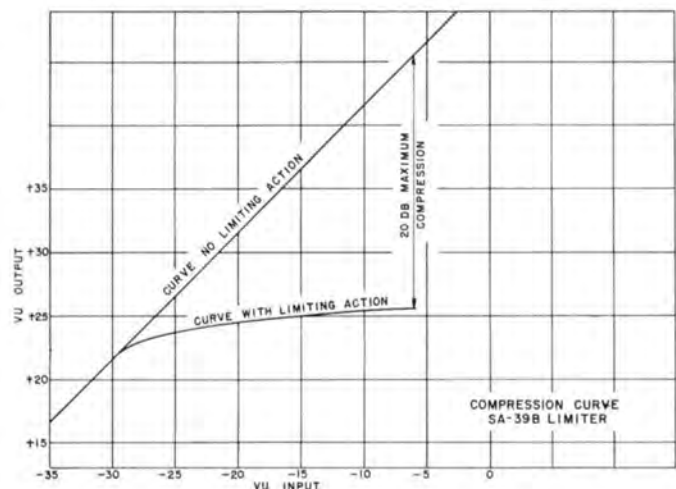
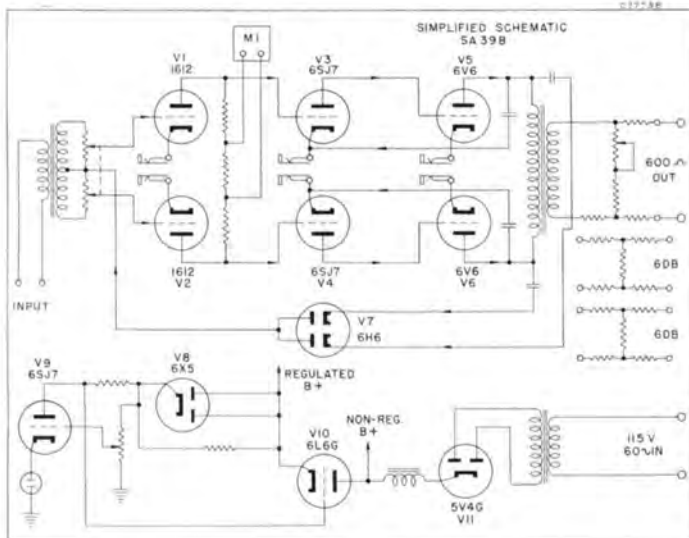

# "STA-LEVEL"

## Automatic Program Level Amplifier



Perhaps no single equipment in all of broadcasting has done so much for so little cost at the Gates "Sta-Level". The basic function is to provide constant level output. "Sta-Level" brings up the low passages as well as holding down excessive output level. The result is always higher level of transmission, the equivalent of greater signal output. **RECOVERY SPEED:** As supplied, "Sta-Level" recovers  $\frac{2}{3}$  level in 7 seconds and 90% level in about 28 seconds. This is considered typical. However, a kit of small fixed resistors is supplied. If the operator feels this is too slow or too fast, he may, by changing two resistors, increase recovery to as fast as  $2\frac{1}{4}$  seconds for  $\frac{2}{3}$  level and 10 seconds for 90% level, or as slow as  $11\frac{1}{4}$  seconds for  $\frac{2}{3}$  level and 45 seconds for 90% level.

**ACCESSORIES:** None needed. "Sta-Level" is a complete one-chassis unit, regulated power supply and all self-contained.

**GAIN:** As "Sta-Level" has up to 62 db gain, if your present system is short of gain, "Sta-Level" will pick it up. Both input and output level controls are on the front panel to adjust for any gain you wish right down to unity or up to the full 62 db.

### SPECIFICATIONS

#### POWER SUPPLY:

Regulated type, self-contained.

#### POWER INPUT:

105/115 volts, 50/60 cycles at 50 watts.

#### RECOVERY:

Switch selects average or dual recovery time to accommodate operational mode best suited to engineering performance. Chart provided as guide.

#### COMPRESSION:

Special regulator circuit holds threshold of compression constant. Rated 0-30 db but excellent performance to 40 db.

#### DISTORTION:

1% or less 50-15,000 cycles 0-30 db of compression when using +20 dbm output threshold level.

#### RESPONSE:

$\pm 1$  db 30-15,000 cycles, 0-30 db compression.

#### NOISE:

65 db below output 0-30 db compression at +20 dbm threshold level.

#### GAIN:

62 db  $\pm 2$  db.

#### IMPEDANCES:

600 omhs input and output.

#### SIZE:

19" x  $5\frac{1}{4}$ " panel, 7" deep. Front panel drops down to service all internal parts.

#### WEIGHT:

40 lbs. net.

#### CUBAGE:

1.9 cu. ft.

#### TUBES:

Two 6V6, one each 6386, 12AT7, 6AL5, OB2, 5Y3GT.

#### FINISH:

Medium gloss gray with lettering in white.

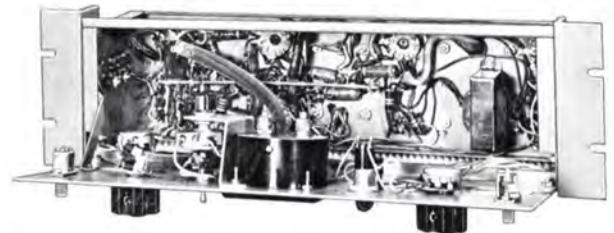

Front panel drops down for complete inner servicing. Big advantage of this type of construction is ability to keep important inner workings clean by means of bellows or small suction type cleaner.

### ORDERING INFORMATION

"Sta-Level" complete with tubes and ready to operate..... M-5167  
Spare 100% tube kit for above..... TK-243

# LEVEL DEVIL

## Program Gated Amplifier



"Level Devil" accepts input signals over a 30 db range and holds the output constant (0 to +3 db). The expander threshold is -10 db relative, and below this the "Level Devil" is a linear amplifier. At this level the gain increases 10 db, and above it the amplifier acts as a peak limiter.

When there is no signal the "Level Devil" does not return to full gain but 10 db less — keeping background noise, sound track noise, tape noise and disc noise at a low, non-objectionable level. Thus, input levels as much as 10 db below normal are expanded to normal output level, but input signals below this level do not cause expansion. It can safely be stated that a signal-to-noise ratio of 13 db or lower will not be expanded.

Separate switches control the expander and limiter so that "Level Devil" may be used as an expanding amplifier alone or a limiting amplifier alone. Field testing has shown

that "Level Devil" used with TV or FM without a peak limiting amplifier has an overshoot of not more than 1 db as observed with the application of a 10 db increase of a complex wave input signal. While this operation is considered satisfactory for TV or FM, a peak limiting amplifier is desirable with "Level Devil" for AM operation.

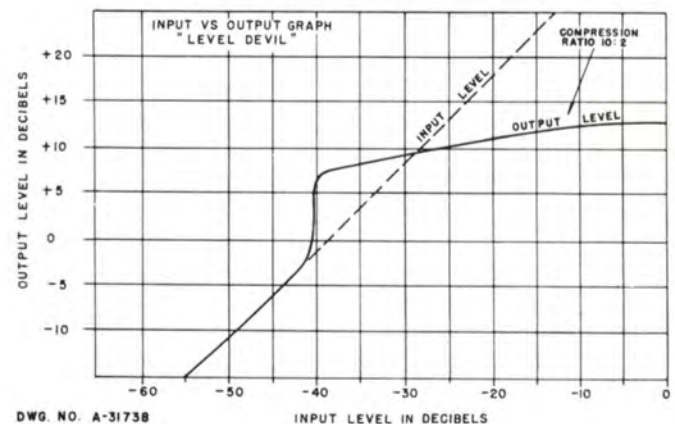



## LEVEL DEVIL PROGRAM GATED AMPLIFIER

### LEVEL DEVIL SPECIFICATIONS

#### IMPEDANCES:

Input and output 600 ohms.

#### INPUT LEVEL:

-35 VU to +27 VU. (10 db and 20 db input pads incorporated.)

#### OUTPUT LEVEL:

+8 VU (includes 6 db H-type line isolation pad).

#### DISTORTION:

1% or less 50-10,000 cycles up to 10 db limiting.

2% or less up to 25 db limiting.

#### RESPONSE:

±1 db 30-15,000 cycles.

#### ELECTRICAL NOISE:

-60 db or better below 10 db limiting.

#### MAXIMUM EXPANSION:

10 db. (NOTE: Level Devil can release 5 db of compression and expand 10 db, giving effective signal increase of 15 db.)

#### MAXIMUM LIMITING:

25 db.

#### LIMITER ATTACK TIME:

10 milliseconds.

#### LIMITER RELEASE TIME:

1½ to 2 seconds.

#### EXPANDER RISE TIME:

2 seconds.

#### EXPANDER RELEASE TIME:

4 seconds.

#### GAIN:

50 db without expansion or limiting.

#### POWER INPUT:

105/125 volts, 50/60 cycles at 55 watts.

#### FUSING:

Type 3AG, 1 ampere.

#### SIZE:

19" wide, 8¾" high, 8½" deep.

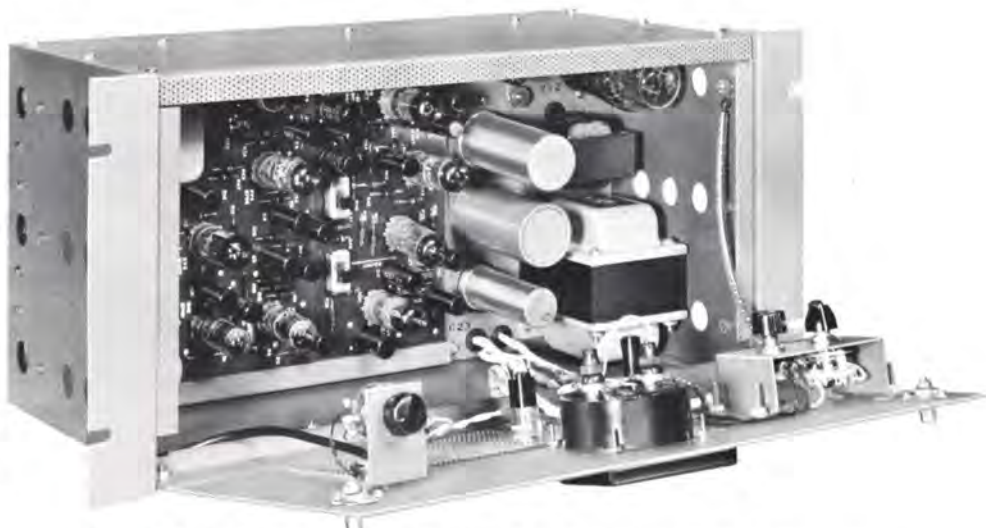

Hinged-down front panel permits complete front accessibility of components and inner servicing adjustments. Printed wiring by the Gates solid adhesion process assures uniformity and ease in both cleaning and circuit analysis. "Level Devil" finish is a medium gloss gray over a heavy prime coat. Design is for continuous duty.

#### WEIGHT:

Net 28 lbs. Gross 35 lbs. Cubage 2.

#### TUBES:

Two each 5749, 12AU7, 12AT7, 12AX7 and OB2.  
One each EF86 and 5V4G.

#### FINISH:

Medium gloss gray.

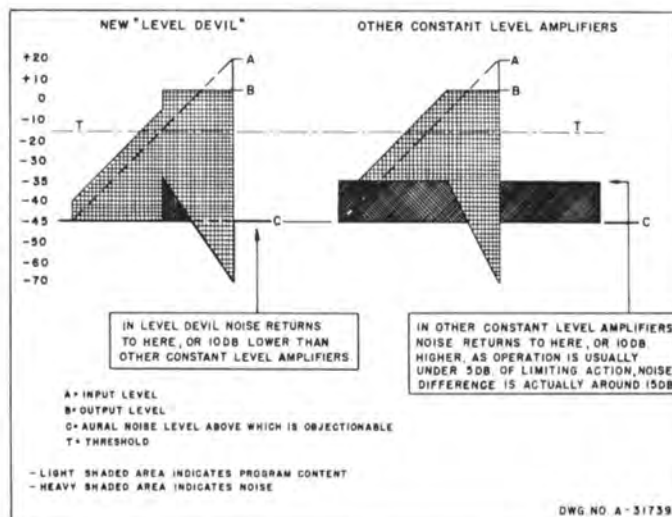

### ORDERING INFORMATION

"Level Devil" complete with tubes

M-5546

100% spare tube kit for above

TK-331

## ULTRA LINEAR MONITORING AMPLIFIER Model M-5575

The M-5575 is a high fidelity, high gain, 10 watt broadcast amplifier. It is ideal for monitoring, recording, audition or as a standby line or program amplifier. A two-stage monitor booster amplifier operates ahead of the three-stage monitoring amplifier, with the gain control between the two amplifiers. The front panel drops down to reach all under-chassis parts. Panel equipment includes gain control, AC switch, pilot light and fuse.



### SPECIFICATIONS

**GAIN:**  
Maximum, 100 db  $\pm$  2 db. Bridging, 50 db  $\pm$  2 db.

**FREQUENCY RESPONSE:**  
 $\pm$  1 1/2 db, 30-15,000 cycles.

**HARMONIC DISTORTION:**  
1% or less 50-15,000 cycles at +40 dbm output (10 watts).

**IMPEDANCES:**  
Input 30/50 or 150/250 at full gain of 100 db. 30,000 ohms at gain of 50 db. Output 8 or 16 ohms (see matching transformer below).

**NOISE:**  
60 db or better below +40 dbm measured at -50 dbm input.

**TUBES:**  
(3) 12AX7, (2) EL84, (1) GZ34 or 5V4, (1) OA2, (1) OB2.

**POWER SOURCE:**  
105/125 volts, 50/60 cycles.

**POWER CONSUMPTION:**  
85 watts.

**SIZE:**  
19" wide, 7" high, 8" deep.

**WEIGHT:**  
Net 18 lbs. Packed, 34 lbs. Cubage 2 1/2.

**SPEAKER MATCHING TRANSFORMER:**  
Optional accessory where many speakers are employed. Primary 48 ohms. Secondary 8 ohms. Permits loading as many as 8 speakers to output of amplifier. Transformer is installed with speaker. (Cat. A-30601)

### ORDERING INFORMATION

Ultra Linear Monitoring Amplifier..... M-5575  
100% Spare Tube Kit for above..... TK-303

## PROGRAM OR LINE AMPLIFIER Model M-5576B

The M-5576 is a high gain, low distortion broadcast amplifier ideal for use in bridging, isolation, program or line amplifier applications. It has four amplifier stages with a dual grid gain control, having one section in the grid of the second stage and the second section in the grid of the third stage. In this manner the lowest noise ratio is always maintained. The front panel drops down to reach all under chassis components. Front panel equipment includes gain control, AC switch, fuse and neon pilot light.



### SPECIFICATIONS

**GAIN:**  
75 db  $\pm$  2 db.

**FREQUENCY RESPONSE:**  
 $\pm$  1.5 db from 30 to 15,000 cycles.

**HARMONIC DISTORTION:**  
0.5% or less 50-15,000 cycles +12 dbm output.  
0.75% or less 30-15,000 cycles at +12 dbm output.  
1% or less 50-15,000 cycles at +22 dbm output.

**IMPEDANCES:**  
Input 150/250 or 500/600 ohms. Output 150/250 or 500/600 ohms.

**NOISE:**  
60 db or better below -60 dbm input at +12 dbm output or equivalent to -120 dbm relative input noise.

**TUBES:**  
(3) EF86, (1) 12AU7, and (1) 6x4 rectifier.

**POWER SOURCE:**  
105/125 volts, 50/60 cycles.

**POWER CONSUMPTION:**  
15 watts.

**SIZE:**  
19" wide, 5 1/4" high, 7 1/2" deep.

**WEIGHT:**  
Net 12 lbs. Packed 27 lbs. Cubage 2.

### ORDERING INFORMATION

Program or line amplifier complete with tubes..... M-5576B  
100% spare tube kit for above..... TK-450

## "UNI-QUE" CUEING AMPLIFIER Model M-5377

The "Uni-Que" is a compact low cost amplifier for remote line monitoring and turntable cue or for information type monitoring in TV news rooms, TV studio areas and offices. Supplied for rack mounting it contains an eleven-position input switch for selection to ten circuits and off. Designed with self-contained loudspeaker and silicon rectifier power supply. The high gain permits cueing directly from turntable or microphone channels and a gain control is front panel mounted for exact adjustment.



### SPECIFICATIONS

**GAIN:**  
70 db  $\pm$  2 db.

**FREQUENCY RESPONSE:**  
Peaked for high intelligibility.

**HARMONIC DISTORTION:**  
3% or less, 50-10,000 cycles at +30 dbm output.

**INPUT LEVEL:**  
At low impedance -20 dbm.  
At bridging +22 dbm.

**IMPEDANCES:**  
Input 30/50 or 150/250 ohms.

Bridging: 10,000 ohms.  
Output 4 ohms to terminals and strapped back to speaker so speaker line may be broken by muting relay.

**NOISE:**  
50 db or better below +30 dbm output measured at -50 dbm input or mixing bus level.

**POWER SOURCE:**  
105/125 volts, 50/60 cycles.

**POWER CONSUMPTION:**  
23 watts.\*

**TUBES:**  
12AX7, 50C5 and M-500 silicon rectifier.

**SIZE:**  
19" wide, 3 1/2" high, 6 1/2" deep.

**WEIGHT:**  
Net 10 lbs. Packed 16 lbs. Cubage 1.

**FINISH:**  
Medium gloss gray, lettering in white.  
\*Power supply is transformer isolated to power line and no AC/DC.

### ORDERING INFORMATION

"UniQue" rack mount with tubes..... M-5377  
Spare tube kit..... TK-305

# DYNAMOTE

## Portable Remote Amplifier



The Gates Dynamote provides 4 mixing channels to handle 4 or less low impedance microphones of any type. It features: hinged illuminated 4" VU meter which swings to high level for broadcasting and folds flush when not in use; lightweight welded frame with amplifier, power supply, front panels with controls and meter and back panels for connectors and terminations attached; rugged basswood carrying case covered with heavy grade leatherette; large handle and nickel hardware. Dynamote provides four audio stages with 15 db feedback and full output of +22 dbm at 1% distortion. Isolation pad with 4 db output provides final maximum output of +18 dbm for no more than 1% distortion. A 10 db range above the maximum permissible level of +8 dbm into telephone is also provided. Mixing controls are Daven, ladder type, 20 steps of 2 db. Input is either 50 or 150 ohms. Battery standby with automatic changeover in the event of power failure is optionally available.

### SPECIFICATIONS

#### MIXING CHANNELS:

Four at 50/150 ohms.

#### POWER SUPPLY:

Full wave transformer type with AC isolated.

#### GAIN:

90 db +3 db from microphone input to line output.

#### FREQUENCY RESPONSE:

+1.5 db 30-15,000 cycles.

#### HARMONIC DISTORTION:

1% or less 50-15,000 cycles at +18 dbm output.

#### SOURCE IMPEDANCE:

30/50 or 150/250 ohms.

#### LOAD IMPEDANCE:

150/250 or 500/600 ohms.

#### POWER REQUIREMENTS:

115 volts, 50/60 cps. at 40 watts.

#### NOISE:

60 db below +8 dbm at -50 dbm input.

#### POWER SOURCE:

115 volts, 50/60 cycles.

#### TUBE TYPES:

(3) 6267/EF86, (1) 12AU7, 6X4.

#### SIZE:

5<sup>7</sup>/<sub>8</sub>" high, 10<sup>1</sup>/<sub>4</sub>" wide and 17<sup>3</sup>/<sub>4</sub>" deep — battery compartment attached.

#### WEIGHT:

22 lbs. less batteries, 29 lbs. with batteries.

#### METER:

4" VU scale B illuminated, adjusted 0 VU indication at +8 dbm.

#### OUTPUT JACKS:

Front jack across line amplifier output. Rear jack No. 1 across line being used. Rear jack No. 2 order phone across line not being used and parallels order phone terminals.

#### BATTERIES (if used):

2 type FP4, A batteries.

5 type XX30, B batteries.

### ORDERING INFORMATION

Dynamote with tubes, Cannon XL receptacles and carrying case	M-4880F
Dynamote with tubes, Cannon P receptacles and carrying case	M-4880G
Continumatic battery compartment with relay and plug, less batteries	M-4933
100% spare tube complement	TK-443
100% set of batteries	M-4983
Male microphone connector for XL receptacles	XLR-3-12C
Male microphone connector for P receptacles	P3-CG-12S

# BIAMOTE

## Two-Channel Remote Amplifier



Unsurpassed remote pickup performance is provided by this popular two channel remote amplifier which utilizes ladder type mixers, a 4 inch VU meter and a high quality meter gain control.

The Gates Biamote combines top performance with rugged design to fill the frequent need for 2 microphone remotes. Its total weight is only 15 $\frac{1}{4}$  lbs. with steel cabinet. Front panel slopes at approximately 12° and has only 5" height for unobstructed view—yet full size 4" illuminated VU meter is retained. All terminations are to the rear including on-off switch, line connections, headphone jack, microphone receptacles and power cord. Finish is gloss gray with dial plates in etched aluminum. Cannon type XL receptacles are provided.

### SPECIFICATIONS

#### MIXING CHANNELS:

Two.

#### GAIN:

90 db  $\pm$  3 db from microphone input to line terminals.

#### FREQUENCY RESPONSE:

+2 db 30-15,000 cycles.

#### HARMONIC DISTORTION:

1% or less 50-15,000 cycles + 18 dbm output.

#### SOURCE IMPEDANCE:

30/50 or 150/250 ohms.

#### LOAD IMPEDANCE:

150/250 or 500/600 ohms.

#### POWER REQUIREMENTS:

115 volts, 50/60 cps. at 40 watts.

#### NOISE:

60 db below +8 dbm at -50 dbm input, equivalent to -110 dbm measured with mixer wide open and master gain adjusted.

#### POWER SOURCE:

115 volts, 50/60 cycles.

#### TUBE TYPES:

(3) 6267/EF86, (1) 12AU7, 6X4.

#### SIZE:

14" wide, 8 $\frac{1}{2}$ " deep, 5" high.

#### WEIGHT:

15 $\frac{1}{4}$  lbs.

### ORDERING INFORMATION

"Biamote" with tubes, less male microphone connectors.....	M-5136A
Male microphone connector.....	XLR-3-12C
100% spare tube complement.....	TK-443



# TWINSISTOR

## 2-CHANNEL REMOTE AMPLIFIER

### Completely Transistorized



Fully transistorized and designed as a compact, light weight, two-channel remote amplifier, the Twinsistor provides top performance for AM, FM or TV remote pickups. The Gates Twinsistor provides 2 microphone channels, VU meter, generous gain, low current battery operation and a total weight of 7 lbs. including carrying case. Response exceeds and distortion is far less than most grade A telephone lines. Camera-type plastic carrying case holds amplifier, headphones and one average microphone with cable is 10½" wide, 8" high, 3½" deep and has adjustable shoulder strap.

Six transistors comprise a 4-stage temperature-stabilized amplifier with push-pull output. Amplifier holds two battery kits with changeover switch on rear of case. Cannon XL microphone receptacles. Meter is standardized 3" VU with fixed pad for +8 VU output at zero scale. Attenuators may be operated at any setting without overload or noise increase. Amplifier turns on when headphones are inserted in jack.

#### SPECIFICATIONS

##### MIXING CHANNELS:

Two at high level (transistor preamplifier for each stage).

##### POWER SUPPLY:

M-5339 mercury battery kit.

##### GAIN:

78 db + 2 db from mic input to line output.

##### FREQUENCY RESPONSE:

±2 db at 70-15,000 cycles.

##### HARMONIC DISTORTION:

2% or less 70-10,000 cycles at +14 dbm.

##### SOURCE IMPEDANCE:

30/50 or 150/250 ohms.

##### LOAD IMPEDANCE:

500/600 ohms.

##### NOISE:

55 to 60 db below +14 dbm measured at -60 dbm input.

##### TRANSISTOR TYPES:

(3) 2N104, 2N44.

##### SIZE:

(Amplifier) 7½" deep, 7" wide, 3⅛" high.  
(Case) 10½" wide, 8" high, 3½" deep.

##### WEIGHT:

(In case) 7 lbs., (less case) 5½ lbs.

##### BATTERIES:

Three 8 volt mercury in kit M-5339. Provision for 2 sets with switch changeover.

##### BATTERY LIFE:

Approximately 80 hours per set.

#### ORDERING INFORMATION

"Twinsistor" complete with carrying case and one set of batteries	M-5168
Male microphone connector	XLR-3-12C
Battery kit	M-5339
Microphone with swivel to plug in back of "Twinsistor"	M-5332

**GATES**

# UNIMOTE

## Single-Channel Remote Amplifier



The M-5531 Unimote will perform equally well as a microphone preamplifier, turntable preamplifier, program amplifier up to 18 dbm output, repeater amplifier, isolation amplifier or as a standby amplifier for quick connection to an emergency circuit. The cover is easily removable for 100% accessibility by flipping two snap locks. Includes front panel gain control and Cannon XL-3 connector.

### SPECIFICATIONS

#### IMPEDANCES:

Input 30/50 or 150/250 ohms.

Output 150/250 or 500/600 ohms.

#### POWER SUPPLY:

105/125 volts, 50/60 cycles.

#### POWER CONSUMPTION:

15 watts.

#### WEIGHT:

11 lbs.

#### TUBES:

(2) EF86, (1) 12AU7 and (1) 6X4 rectifier.

#### GAIN:

81 db  $\pm$  2 db.

#### DISTORTION:

1% or less +8 dbm output.

1 1/2% or less at +18 dbm output.

#### RESPONSE:

$\pm$  1 1/2 db from 30-15,000 cycles.

#### NOISE:

60 db or better below +8 dbm output measured with  
-60 dbm input or -120 db relative input noise.

#### SIZE:

11" wide, 5 3/4" high and 5" deep.

### ORDERING INFORMATION

"Unimote" Amplifier with tubes and

XL3-13 microphone connector ..... M-5531

100% spare tube kit for above ..... TK-280

Microphone connector (male), Cannon ..... XLR-3-12C

## M-5530 ALL-PURPOSE UTILITY AMPLIFIER

The M-5530 Utility Amplifier may be used as a single channel remote amplifier with nothing else to buy except microphone and XL3-13 microphone connector, a high gain, low noise turntable preamplifier possessing the extra gain needed for modern low level pickups through passive equalizers, a line, repeater or program amplifier and a microphone amplifier for feeding professional high level input tape recorders.

### SPECIFICATIONS

#### IMPEDANCES:

Input 30/50 or 150/250 ohms.

Output 150/250 or 500/600 ohms.

#### GAIN:

From microphone input to program line output 81 db  
 $\pm$  2 db.

#### AUDIO RESPONSE:

$\pm$  1 1/2 db, 30 to 15,000 cycles.

#### NOISE:

60 db or better below +8 dbm output measured at  
-60 dbm input. Equivalent input noise is -120 dbm.

#### DISTORTION:

1% or less 50 to 15,000 cycles at +8 dbm output.

1 1/2% or less 50 to 15,000 cycles at +18 dbm output.

#### TUBES:

(1) EF86 1st audio (1) EF86 2nd audio (1) 12AU7  
3rd audio (1) 6x4 rectifier.

#### TOTAL TUBES:

4.

#### TOTAL TUBE TYPES:

3.

#### SIZE:

11" wide, 5 3/4" deep, 5" high.



#### WEIGHT:

6 lbs. net, 9 lbs. packed.

#### CUBAGE:

1.6.

#### POWER SUPPLY:

105/125 volts, 50/60 cycles.

#### POWER CONSUMPTION:

15 watts.

#### TERMINATIONS:

Terminal strips.

#### FINISH:

Medium gloss gray.

### ORDERING INFORMATION

Model M-5530 all-purpose utility amplifier with tubes ..... M-5530

Spare 100% spare tube complement for above ..... TK-280

Chassis connector where used with microphone ..... XL3-13

(Optional—not included as illustrated.)

Microphone plug for above chassis connector ..... XLR-3-12C

# VU METER PANEL, SWITCH & FUSE, JACK PANELS

## V-22 VOLUME INDICATOR

A complete range set with 10 position input selector switch. In this way, all circuits to be measured may be switched in, including proof of performance. Meter is 4" illuminated. Range control in 2 VU steps from +4 to +42 VU. Input impedance 7500 ohms to bridge at 500/600 ohm line. Panel 5 1/4" x 19". Finish, medium gloss gray. Weight 4 lbs. net. VU-22 Volume Indicator ..... M-4577



## SWITCH AND FUSE PANEL

Performs as a master input control of the AC power. Used for turning On-Off all equipment in one relay rack. Two plug fuses mount behind snap-on front panel.

Includes indicator lamps and switch.  
 Switch: D.P.S.T., 115 volts, 15 amps.  
 Size: 3 1/2" x 19". Weight: 3 lbs. net.  
 Finish: Medium gray.

Switch and Fuse Panel ..... M-4242

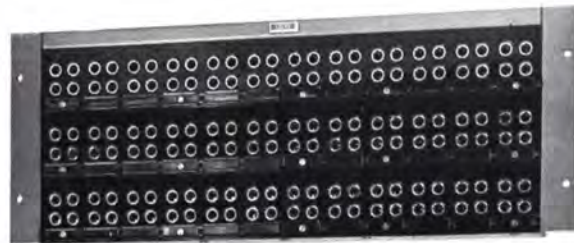
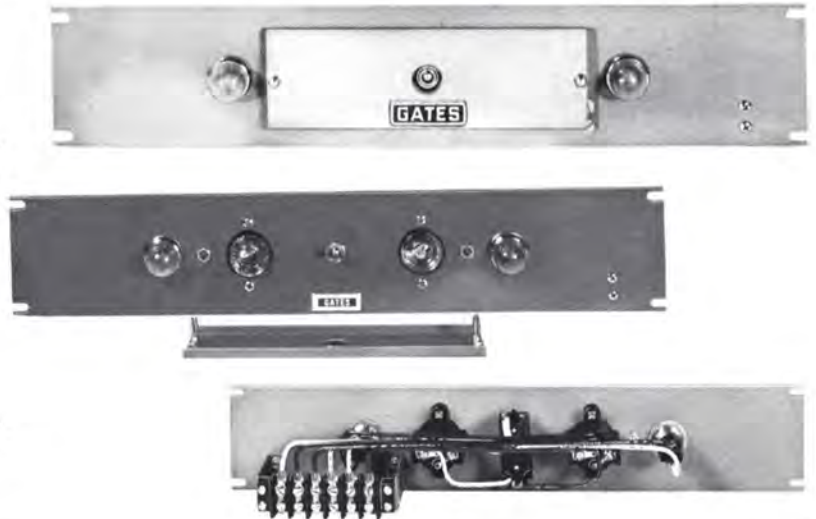

Above, three PJ-341 jack panels mounted on PD3 jack mat. Has 144 jacks (72 pairs). Panel Size: 7" x 19".



Above, two PJ-341 jack panels mounted on PD2 jack mat. Has 96 jacks (48 pairs). Panel Size: 5 1/4" x 19".



Above, one PJ-341 jack panel mounted on PD1 jack mat. Has 48 jacks (24 pairs). Panel Size: 3 1/2" x 19".

## JACK PANELS

Industry standard double jack assemblies. Jack strips listed separately from jack mats for ease in ordering. All jacks closed circuit type for normalling through audio circuits. Non-aging, non-ferrous metal assures long lasting spring tension. Contacts of silver alloy. Jacks held by molded bakelite, steel reinforced. Individual designation strips with slip-in holders for each pair of jacks.

- Jack strip (24 jacks) with mounting brackets ..... PJ-343
- Jack strip (48 jacks) less mat ..... PJ-341
- Jack mat for one C-1500 jack strip ..... PD-1
- Jack mat for two C-1500 jack strips ..... PD-2
- Jack mat for three C-1500 jack strips ..... PD-3
- Patch cord 2' long ..... PJ-12
- Patch cord 3' long ..... PJ-13
- Patch cord 4' long ..... PJ-14
- Patch cord 5' long ..... PJ-15



Patch cords available in four lengths. Double plugs each end. Shielded and covered with durable black braid plus extra reinforcement 6" from each end.



Above, PJ-343 jack panel has 24 jacks (12 pairs). Size: 1 3/4" x 19". Does not require jack mat. End brackets for rack mounting supplied.

## PROOF OF PERFORMANCE EQUIPMENT

### MODEL 210 AUDIO OSCILLATOR

The Model 210 Audio Oscillator is a source for low distortion signals from 10 to 100,000 cycles. The circuit consists of an RC audio circuit followed by an amplifier of extremely low distortion.

#### SPECIFICATIONS

- FREQUENCY RANGE:**  
10 cps to 100 KC.
- FREQUENCY RESPONSE:**  
±1 db over entire range when connected to its characteristic 600 ohm output. Referenced at 5 KC.
- CALIBRATION:**  
±2%, over entire range. 10 cps to 100 KC.
- POWER OUTPUT:**  
Up to 10 volts into 600 ohm load.
- WAVE FORM DISTORTION:**  
Less than .2% at 5 volts output from 50-20,000 cps. Slightly higher at greater output levels and frequency extremes.
- INTEGRAL POWER SUPPLY:**  
Operates from 115 volts AC, 50/60 cycles single phase. Power consumption 50 watts.
- SIZE AND WEIGHT:**  
Width 6", height 12", depth 12". Overall weight 11 lbs.



Model 210 Audio Oscillator

### MODEL 410 DISTORTION METER

The Model 410 Distortion Meter measures audio distortion, noise level, audio gain or loss in DBs and AC voltages. In measuring distortion the instrument suppresses the fundamental frequency and measures the amplitude of all unwanted frequencies, including noise, as a percentage of the fundamental.

#### SPECIFICATIONS

- DISTORTION RANGES PROVIDED:**  
1% full scale, 3%, 10%, 30% and 100%.
- INPUT IMPEDANCES:**  
Designed for optimum accuracy on 600 ohms, satisfactory on sources up to 100,000 ohms.
- FREQUENCY RANGE:**  
20 to 200,000 cps.
- CALIBRATION:**  
Calibrated in 1 db steps from 0 db to -15 db. Attenuator provides additional ranges from -60 db to +50 db in 10 db steps.
- POWER SUPPLY:**  
Operates from 115 watts AC, 50/60 cycles single phase. Power consumption 50 watts.
- SIZE AND WEIGHT:**  
Width 11 1/4", Height 9". Overall Weight 11 lbs.



Model 410 Distortion Meter

### GAIN AND MEASURING SET

Ideal for use with above oscillator and distortion meter but may be used with any similar equipment. Consists of VU meter and associated switches to accommodate all usable ranges for measuring. Attenuation circuit includes a 10 step, 2 db per step, variable attenuator balanced ladder type, and three fixed plug-in pads. Pads are used for attenuation and impedance matching. Two pads have 40 db attenuation at 600/600 ohms and one has 20 db at 600/250 ohms, all balanced H. Additional pads of any loss or impedance obtainable on special order.

#### SPECIFICATIONS

- INPUT IMPEDANCE:**  
600 ohms balanced.
- OUTPUT IMPEDANCE:**  
30 to 600 ohms balanced.
- OUTPUT LEVEL:**  
Variable from -21 dbm to -36 dbm.
- RESPONSE:**  
±1/2 db 30-15,000 cycles.
- DISTORTION AND NOISE:**  
Negligible.



Model M-3526  
Gain Measuring Set

### M-3626 RECTIFIER/PICKUP COIL

Used with AM transmitters in conjunction with Model 410 distortion meter. Picks up RF from tank circuit for measuring noise and distortion. Includes RF pickup coil, 15-foot section of coaxial cable, and germanium diode. Complete RF filtering guarantees pure audio output which is free from RF disturbances.

- FREQUENCY RANGE:**  
550-20,000 Kc.
- RESPONSE:**  
±1 db 30-15,000 cycles.
- OUTPUT IMPEDANCE:**  
600 ohms.
- OUTPUT LEVEL:**  
+12 dbm.

### COMPLETE PROOF OF PERFORMANCE PACKAGE

Consists of Type 210 Oscillator, Type 410 Noise and Distortion Meter, M-3625 Gain Measuring set, and M-3626 Rectifier Unit with RF pickup coil and transmission line cable. Complete package provides all facilities for proof of performance of both audio frequency and AM radio transmitters. Provided with this package is a complete instruction book covering not only instructions for operating the equipment but suggested methods in making proof of performance measurements that are accurate and reliable. Model SA-131 Complete Proof of Performance Package.

### FIXED AND VARIABLE EQUALIZERS



MODEL LE-1: Shown to left is a fixed equalizer. A parallel resonant circuit operating with either a 150 or 600 ohm line. Equalization is varied by means of self-contained resistors in 1 ohm steps up to 111 ohms. Inductance is tuned by 0.05 mfd. and 0.025 capacitors, also self-contained.

SIZE: 2 1/2" x 2 1/2" x 3". Ideal for equalizing telephone lines or any circuit requiring correction.

FIXED EQUALIZER

LE-1



MODEL LE-2: Consists of the LE-1 equalizer with two variable controls, inserting the resistance in 1 ohm steps up to 111 ohms as required for full equalization. A double jack input is provided for direct parallel patching. Provision is also made for mounting a variable attenuator, sometimes desired in controlling line level. Panel Size: 19" x 3 1/2". Finish, medium gray.

VARIABLE EQUALIZER

LE-2



# RACK CABINET RAK-1

A unit system type of rack cabinet of open frame construction, having removable sides along with various shields, joiner trims and end bells. Rack mounting strips are movable from front to back in 6 steps of 1 1/4". Basic frame includes 2 panel mounting angles, 2 terminal board mounting angles, full size rear door and panel mounting screws. Other accessories are as follows:

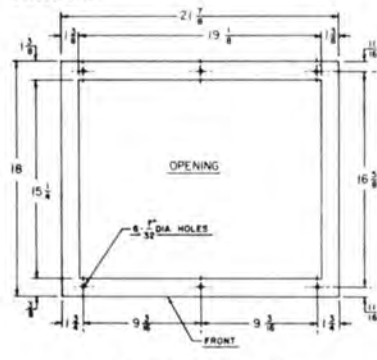

### SPECIFICATIONS

HEIGHT OVERALL: 84".  
 WIDTH (less SP-1 side panel): 22".  
 WIDTH OF SP-1 SIDE PANEL: 3".  
 DEPTH OVERALL: 21".  
 DOOR SWING: 22 1/2".  
 PANEL SPACE: 19" x 77".  
 MAXIMUM CLEARANCE BEHIND FRONT PANEL: 17".  
 PANEL MOUNTING: Standard rack multiplies 12/24 mounting screws provided.  
 FINISH: Gates Gray.  
 NET WEIGHT RAK-1: 100 lbs. (Basic cabinet)

**SINGLE CORNER TRIM TRM-1:** Covers the rack mounting bolts on each corner. Two used for single cabinet or any number of cabinets.  
**DOUBLE CORNER TRIM TRM-2:** Covers rack mounting bolts and joins two cabinets together. One used to join second cabinet to first, third to second, etc.  
**LARGE SIDE SHIELD SH-1:** An electrical shield plate 15 1/8" x 28" in size.  
**SMALL SIDE SHIELD SH-2:** Same as SH-1 above only 15 1/8" x 21" in size.  
**TERMINAL BOARD MOUNTING BRACKET BRK-1:** Mounts at bottom rear of cabinet for the support of audio and power terminal blocks.  
**SIDE PANELS SP-1:** Commonly known as end bell. Two used for single cabinet or any number of cabinets joined together.

SHIPPING WEIGHT: 120 lbs.

### ORDERING INFORMATION

Basic Cabinet .....	RAK-1
Single Corner Trim .....	TRM-1
Double Corner Trim .....	TRM-2
Side Panel .....	SP-1
Shield .....	SH-1
Shield .....	SH-2
Terminal Board Mounting Bracket .....	BRK-1
Ventilating Fan .....	RAK-F-1



# RACK CABINET RAK-7

The M-5527 is one of the finest rack cabinets in the economy field, and is suitable for all applications, including the mounting of tape recorders. Has solid sides, full size rear door with louvers at top and bottom. Finish is medium gray for both smart appearance and easy cleaning. Standard cabinet is supplied with corner trim strips to cover panel mounting hardware. M-5577 joiner trim is used when joining two cabinets together.

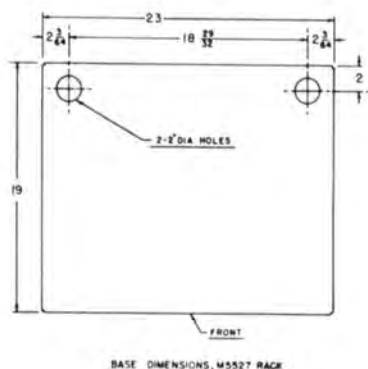

### SPECIFICATIONS

DEPTH OVERALL: 19 1/2".  
 DOOR SWING: 20 1/2".  
 PANEL SPACE: 19" x 71 3/4".  
 CLEARANCE BEHIND PANEL: 17".  
 PANEL MOUNTING: Standard rack multiples 12/24 mounting screws provided.  
 FINISH: Medium gray.  
 NET WEIGHT: 100 lbs.  
 SHIPPING WEIGHT: 125 lbs.  
 HEIGHT OVERALL: 78".  
 WIDTH OVERALL: 23 1/2".

### ORDERING INFORMATION

Rack Cabinet .....	RAK-7
Joiner Trim .....	M-5577



# GATES BROADCAST MICROPHONES

These new Gates professional broadcast microphones are designed and styled for AM, FM or TV broadcast service.

**MODEL G-100 MICROPHONE**—The new Gates G-100 microphone is a dynamic, omnidirectional type designed for high quality broadcasting of both music and speech.

## SPECIFICATIONS

<b>TYPE:</b> Dynamic.	Armco magnetic iron in a nonwelded circuit.
<b>FREQUENCY RESPONSE:</b> Uniform from 60 to 12,000 cps.	<b>CASE:</b> Pressure cast zinc.
<b>IMPEDANCE:</b> 150 ohm balanced.	<b>FINISH:</b> Non-reflecting Gates Gray.
<b>OUTPUT LEVEL:</b> -55 db; RETMA sensitivity rating, -148 db (0 db equals 1 mw/10 dynes/cm <sup>2</sup> ).	<b>CABLE:</b> 18 ft., two-conductor, shielded, synthetic rubber jacketed.
<b>POLAR PATTERN:</b> Essentially omnidirectional.	<b>STAND COUPLER:</b> 3/8 in. -27 thread.
<b>DIAPHRAGM:</b> Acoustalloy.	<b>DIMENSIONS:</b> Diameter: 2 in., Length: 6 1/4 in.
<b>MAGNETIC CIRCUIT:</b> Employs Alnico V and	<b>NET WEIGHT:</b> 1 lb. less cable.



## ORDERING INFORMATION

Gates Dynamic, Omnidirectional Microphone ..... G-100

**MODEL G-200 MICROPHONE**—A dynamic type, omnidirectional microphone, the new Gates G-200 combines slim-trim styling with outstanding performance characteristics.

## SPECIFICATIONS

<b>TYPE:</b> Dynamic.	Armco magnetic iron in a nonwelded circuit.
<b>FREQUENCY RESPONSE:</b> Uniform from 60 to 13,000 cps.	<b>CASE:</b> Steel.
<b>IMPEDANCE:</b> 150 ohm balanced.	<b>FINISH:</b> Non-reflecting Gates Gray.
<b>OUTPUT LEVEL:</b> -55 db; RETMA Sensitivity Rating -149 db (0 db equals 1 mw/10 dynes/cm <sup>2</sup> ).	<b>CABLE:</b> 18 ft., two-conductor, shielded, synthetic rubber jacketed, broadcast type.
<b>POLAR PATTERN:</b> Nondirectional.	<b>STAND COUPLER:</b> 3/8 in. -27 thread.
<b>DIAPHRAGM:</b> Acoustalloy.	<b>DIMENSIONS:</b> Diameter: 1 1/8 in.; Length: 10 1/4 in.
<b>MAGNETIC CIRCUIT:</b> Employs Alnico V and	<b>NET WEIGHT:</b> 15 oz.



## ORDERING INFORMATION

Gates Dynamic, Omnidirectional Microphone ..... G-200

**MODEL G-300 MICROPHONE**—The G-300 is a cardioid microphone of the dynamic type with only one moving element.

## SPECIFICATIONS

<b>TYPE:</b> Cardioid dynamic.	Armco magnetic iron in a nonwelded circuit.
<b>FREQUENCY RESPONSE:</b> Uniform from 40 to 15,000 cps.	<b>CASE:</b> Pressure-cast zinc.
<b>IMPEDANCE:</b> 150-ohm balanced.	<b>FINISH:</b> Non-reflecting Gates Gray.
<b>OUTPUT LEVEL:</b> -55 db; RETMA sensitivity rating, -149 db (0 db equals 1 mw/10 dynes/cm <sup>2</sup> ).	<b>CABLE:</b> 18 ft., two-conductor, shielded, synthetic rubber jacketed, broadcast type.
<b>POLAR PATTERN:</b> Cardioid. Uniform front-to-back discrimination.	<b>STAND COUPLER:</b> 3/8 in. -27 thread on stud.
<b>DIAPHRAGM:</b> Acoustalloy.	<b>DIMENSIONS:</b> Diameter: 1 7/8 in. max. Length: 7 3/16 in., not including stud.
<b>MAGNETIC CIRCUIT:</b> Employs Alnico V and	<b>NET WEIGHT:</b> 1 lb. 10 oz., without cable.



## ORDERING INFORMATION

Gates Dynamic, Cardioid Microphone ..... G-300



# SPEAKERS AND Baffles

"GATESPEAKER" and "GATESOUND" have been developed for the broadcasting industry by the world's leading manufacturer of broadcasting equipment. The purpose of this development program is to provide the finest transition possible from electrical energy to sound energy for monitoring of studio and transmitting equipment. The "Gatespeaker" is designed primarily for use in offices, reception rooms and other points where a high quality monitoring signal is desired. The "Gatesound" is for use in the control room, audition booth and transmitter, where a highly critical reproduction of the station signal or program material is desired.

## GATESPEAKER 8



The Gatespeaker 8 offers increased range, sturdy construction and minimum cost to make this one of the finest monitor speakers available on the market today. The 4.64 oz. magnet and 11 watt power handling capability will reproduce lows down to 50 cycles and highs out to 18,000 cycles.

**SPECIFICATIONS:**

Size, 8"; Magnet weight, 4.64 oz.; Voice coil, 8 ohms; Power 13 watts.

Gatespeaker 8 ..... GRS-800

## GATESPEAKER 12



High quality, big performance and heavy duty construction identify the Gatespeaker 12. It is an ideal monitor speaker for the broadcaster. The 4.64 oz. magnet will handle 13 watts of power and reproduce from 45 to 18,000 cycles.

The voice coil impedance of 8 ohms, over-all depth of 5 1/2" make this an ideal speaker for replacement where increased response, and improved monitoring facilities are desired.

**SPECIFICATIONS:**

Size, 12"; Magnet weight, 4.64 oz.; Voice coil, 8 ohms; Power, 13 watts.

Gatespeaker 12 ..... GRS-1200

## GATESOUND 12



The Gatesound 12 is a high-fidelity speaker for use where full range reproduction is required. A 24 oz. magnet plus other advanced construction features make this one of the very finest high-fidelity loudspeakers on the market today. The Gatesound 12 is exceptionally well suited for use at its full range or as a woofer in three way systems.

**SPECIFICATIONS:**

Size, 12"; Magnet weight, 24 oz.; Voice coil, 8 ohms; Power, 20 watts. 40 to 4500 cycles.

Gatesound 12 ..... GRS-1250

## GATESOUND 15



Incorporating all the design features of the other units in the GATESOUND line, the Gatesound 15 loudspeaker will provide the most discriminating monitoring facilities for base response available. Base response is excellent while smooth even coverage of the midrange spectrum is maintained for monitoring purposes.

**SPECIFICATIONS:**

Size, 15"; Magnet weight, 24 oz.; Voice coil, 8 ohms; Power, 20 watts. 30 to 4500 cycles.

Gatesound 15 ..... GRS-1550

## WALL Baffles BY ARGOS

Modern looking, space saving baffles, for easy mounting. Entire front is insert with plastic grill and cloth panel. This unit is constructed of plywood and hardboard for deep rich bass and clean highs. Available in Blonde or Walnut.

### WALL Baffles



- 8" deluxe wood, walnut or blonde (specify) ..... DWB-8A
- 12" deluxe wood, walnut or blonde (specify) ..... DWB-12A



- 8" fabric covered, walnut or blonde finish (specify) ..... WB-8C
- 12" fabric covered, walnut or blonde finish (specify) ..... WB-12C

### CORNER Baffles



- 8" slanting, walnut or blonde (specify) ..... SCB-8D
- 12" slanting, walnut or blonde (specify) ..... SCB-12D

### SPEAKER TRANSFORMERS AND PADS

Transformer, Pri. 500/1000/1500/2000: Sec. 8 ohms 10 watts	ZY-2002
Transformer, Pri. 500/1000/1500/2000: Sec. 8 ohms 16 watts	ZY-2003
Transformer, Pr. 45 to 50 ohms: Sec. 8 ohms	A-306-1
Pad, 8 ohm T pad	554-0227-000
Pad, 4 ohm T pad	554-0180-000



# ACCESSORIES

## DESK STANDS

**Model 418**  
Heavy die cast base, TV gray finish. For use with small-stud mikes such as Gates G-100 and G-200.



**Model 418-5**  
Stand with on-off switch.



**Model 419**  
Similar to Model 418 but for use with Gates G-300 microphone.

**Model 419-5**  
Stand with on-off switch.

**Model DS-7**  
Adjustable 8" to 13" chrome stem and substantial cast base with felt feet.  $\frac{5}{8}$ " x 27 thread.



## FLEXO MIKESTER CLAMP-ON MIKE STAND

Clamps or screws to any horizontal or angular position. Swings to 36" fully extended. Any mike up to 4 lbs. Model No. 1.



**BANQUET STAND**  
Adjustable 18" to 32" chrome stem and 8" diameter base.  $\frac{5}{8}$ " x 27 thread. Full grip velvet action silent adjustment.  
Banquet Stand TS-6



## MICROPHONE ACCESSORIES

**Model 345 Shock Mount**  
Dual-type, prevents reproduction of external shocks, vibrations. Easily attached, removed. Chrome finish.  $\frac{5}{8}$ " x 27 thread. Size  $3\frac{3}{8}$ " by  $1\frac{1}{2}$ " dia. Net wt. 10 oz.



**Model 524 Wind Screen**  
Minimizes wind effects, boom or outdoor use. Made of Acoustiform rubber. For use with Gates G-300. Net wt. 2 oz.



**Model 335 Blast Filter**  
Acoustically treated to stop wind, breath blasts without affecting frequency response. For Gates G-100. Chrome finish.



## BOOM STANDS



Boom length 62" (more extension addable). Adjustable vertical extension 48"-72". Base diameter 17". Tubular sections superchrome plated. Modernistic base finished in chrome and gun metal shrivel. "Snap On" hangers furnished to hold mike cable to boom section. Ship. Wt. 33 lbs.

Boom Stand without casters BS-36  
Boom Stand with silent casters BS-36W

## STUDIO WARNING LIGHT



An attractive and modern design light available in many different wordings. Lettering is on plexiglass and illumination is edgewise, illuminating letters only. Size: 18" wide,  $6\frac{1}{2}$ " from top of glass to base of lamp enclosure, 3" deep.

Lettering	Cat. No.
Studio A	AM-1
Studio B	AM-2
Control Room	AM-3
On Air	AM-4
Special Lettering*	AM-5

\*12 or less letters or numbers.

## FLOOR STANDS



A floor stand with a big heavy base, listed to left above. Weight 24 lbs., and base 17" across. Adjustable to 66". Full chrome with gray base.  $\frac{5}{8}$ " x 27 thread. Non-slipping clutch. Fits all microphones listed in this catalog.

Microphone Floor Stand MS-25

Here is a good medium-priced floor stand with a 10" diameter base, chrome pipe and gray base. Adjustable to 64" with  $\frac{5}{8}$ " x 27 thread and non-slipping clutch. Weight 9 lbs.

Microphone Floor Stand MS-10C

## BOOM BRACKET

A boom bracket to attach to any existing floor stand with  $\frac{5}{8}$ " x 27 thread. 32" long, chrome plated. Counter balance adjustable for various microphones.

Boom Bracket BB-1

## HEAD PHONES



BRUSH DUAL CRYSTAL UNIT as illustrated. Smartly styled, unusually sensitive and dependable. For all professional service.

Dual Head Set BA-200

BRUSH SINGLE HEAD SET with head band. Otherwise same as dual unit above.

Single Head Set BA-201

TRIM DUAL HEAD SET, feather weight model, long recognized as an industry leader. Impedance 24,000 ohms.

Trim dual head set 107

TRIM S HEAD SET, particularly designed for broadcast use. Response substantially flat through all essential frequencies. Shell and cap molded plastic. Alnico V magnet. Floating diaphragm. Supplied with cushions. Impedance 600 ohms.

Trim S head set 35-3

## STUDIO CLOCKS



SESSIONS clock has large sweep second hand and bold black numerals on a white dial. Size:  $13\frac{1}{2}$ " diameter. Very accurate and time set is at bottom front. Finish gray, non-glaring, 115 volts, 60 cycles.

Sessions Electric Clock RB-89



SETH THOMAS. Thin design, bright chrome finish, convex glass with bold black lettering and easy to see second hand. Sets from front. This clock 15" in diameter with  $12\frac{1}{2}$ " dial and only  $1\frac{3}{4}$ " deep. 115 volts, 60 cycles.

Seth Thomas Electric Clock 602

# ACCESSORIES

## STUDIO AND MICROPHONE CABLE

### STUDIO CABLE



Shielded 2-conductor No. 20 stranded, cloth and heavy cotton fabric with tinned copper shield overall. Finest quality for studio audio wiring. Packaged in 250', 500' and 1000' lengths. SH-20  
 Shielded 2-conductor No. 22 solid enameled, cotton wrap and cotton braid waxed. Tinned copper shield. Has 22 AWG tinned solid copper wire under shield and tubed chrome vinyl plastic jacket. Small size 0.185" diameter. Packaged 100', 500', 1000' spools. 8440  
 A very small 2-conductor shielded cable frequently used in rack wiring. OD .125". Has 2-conductor 16/36 stranded plastic insulation of each conductor with tinned copper shield overall. Packaged 250', 500' and 1000' spools. 1261  
 Shielded 2-conductor No. 18 stranded for power cabling. Has rubber insulation and overall rubber jacket. OD .9295". Available in 50' and 100' spools. 8428  
 Shielded 2-conductor No. 22 solid, spiral wrap shield, vinyl jacket 8436

### MICROPHONE CABLE

Rubber jacketed shielded highly flexible 2-conductor microphone cable of high commercial quality. Available any length as ordered. Per foot MIC-100  
 Single conductor shielded rubber jacketed microphone cable. 8410

## CANNON XLR CONNECTORS



Popular small size Cannon connector used universally in radio and TV.

- | Symbol | Description                           | Cat. No.   |
|--------|---------------------------------------|------------|
| G      | Single, 3 prong, female, 1 wall plate | XLR3-35-2G |
| H      | Cable plug, 3 prong, male             | XLR3-12G   |
| I      | Cable receptacle, female, 3 prong     | XLR3-11C   |
| J      | Chassis receptacle, female, 3 prong   | XLR3-13    |
| K      | Chassis receptacle, male, 3 prong     | XLR3-14    |

## BULK TAPE ERASER



Bulk tape demagnetizer developing high intensity magnetic field. Erases recorded signals and noise completely and restores tape to like new condition. Handles 5", 7" and 10 1/2" reels. Adapter hub available (optional accessory) for 10 1/2" reels. 117 volts, 50/60 cycles.  
 Tape eraser HD-11M

## TAPE SPLICER



The accepted standard of both professional and industrial users. Performs equally well for monaural and 2 track stereo tapes.

Robins Deluxe Splicer Model TS-8D

## TAPE CABINETS



Holds 42 reel boxes of 7" tape reels. 13 1/8" wide, 12 5/8" high, 8 5/8" deep. Has six compartments. May be stacked as desired. TR-742

Holds 21 reel boxes of 10 1/2" tape reels. 13 1/8" wide, 12 5/8" high, 12" deep. Has three compartments. May be stacked as desired. TR-1021

## STYLUS FORCE GAUGE



An inexpensive, yet much needed item, wherever transcriptions are used. Measures pressure in grams of stylus on record.

Stylus gauge 301

## DISC CABINET



Protect those expensive and fragile 12" LP's as they should be. Holds 540 12" LP's with a heavy red wallet for each. Includes two sets of numbers, 1620 printed catalog cards and card file. Size: 60" high, 29" wide and 14" deep. Double door with lock and key.

Disc Storage Cabinet C-540

## AUDIO TERMINAL BLOCK

Has 120 terminals in six rows. Molded one-piece phenolic black with base 3 1/2" x 6 1/8". Height 3 1/2". Terminals plated brass. Polished phenolic finish makes easy removal of solder splash.



Audio terminal block PJ-106

## ELECTRIC GENERATING PLANTS

Electric and diesel generating plants are available in all powers from 1 KW to 500 KW. Pictured above is the popular Onan 25,000 generating plant. Ideal for use in providing complete power for radio and TV stations. Full information, prices, supplied upon receipt of customer's requirements.



# AMPEX PROFESSIONAL TAPE RECORDERS

AMPEX MODEL 351—a monophonic recorder/reproducer available unmounted, console-mounted or portable—two-channel stereo model (351-2) available unmounted or as a portable.

APPLICATIONS—For monophonic (351) or 2-track stereophonic (351-2) recording and reproduction—designed primarily as a broadcast recorder for heavy, continuous duty operation requiring exacting performance characteristics—has also found wide use in recording studios, education, business and research.

AMPEX MODEL 352—a tape playback-only unit available unmounted for rack use or in its own floor console—two-channel stereo model (352-2).

APPLICATIONS—Identical playback functions as 351 recorder/reproducer—the playback-only function reduces cost, eliminates accidental erasure of valuable tapes—lower cost, without sacrificing performance, makes it ideal for: broadcasting and recording industry, commercial background music for businesses and industry, dance studios, education, etc.



Console, One Channel only.



Unmounted (Rack), One and Two Channels.

## SPECIFICATIONS

### SPEEDS:

Dual speeds: 7½ and 15 ips or 3¾ and 7½ ips.

### FREQUENCY RESPONSE:

±2 db, 30-18,000 cps at 15 ips.

### SIGNAL-TO-NOISE:

55 db at 7½ and 15 ips (half track or two track) 60 db, full track.

### FLUTTER AND WOW:

Below 0.15% rms at 15 ips.

### TIMING ACCURACY:

±0.2%.

## ORDERING INFORMATION

30700-05 full track, portable mount, 7½/15 ips ..... 351P	30700-13 full track, unmounted, ¾/7½ ips ..... 351-U
30700-01 full track, unmounted, 7½/15 ips ..... 351-U	30700-15 full track, console mount, ¾/7½ ips ..... 351-C
30700-03 full track, console mount, 7½/15 ips ..... 351-C	9991-01 full track, unmounted 7½/15 ips ..... 352-U
	9991-05 half track, unmounted 7½/15 ips ..... 352-U



Portable One and Two Channels.

AMPEX MODEL PR-10-2—two channel stereo recorder/reproducer records and reproduces stereo, 2-channel mono or conventional (½ track) mono—fourth head position can be used for optional 4-track stereo playback.

APPLICATIONS—Quality performance characteristics and compact size make it an ideal field or studio recorder/player for broadcasters, recording studios, churches, classroom and industrial uses.

MODEL PR-10-1—a one-channel recorder available with full or half-track heads—same transport as PR-10-2.

APPLICATIONS: Same as for PR-10-2 where full or half track monophonic recording and playback is desired.

## SPECIFICATIONS

SPEEDS: Dual speeds: 7½ and 15 ips, or 3¾ and 7½ ips.

FREQUENCY RESPONSE: ±2 db 30-15,000 cps at 15 ips.

SIGNAL-TO-NOISE: 55 db at 15 and 7½ ips (half-track or two-track); 60 db, full-track.

FLUTTER AND WOW: Less than 0.15% rms at 15 ips. 0.18% rms at 7½ ips.

OUTPUT: +4 dbm into 600 ohm balanced or unbalanced load.

INPUTS: PR-10-1: Separate microphone and line inputs. PR-10-2: One line input for each channel. Microphone preamps or line transformers may be used with line inputs.

DIMENSIONS: Transport: 8¾" x 19" x 6" D. Electronics: 5¼" x 19" x 5⅞" D. Weight: unmounted, 44 lbs.; portable, 53 lbs.

## ORDERING INFORMATION

96001-09 full track, unmounted, 7½/15 ips ..... PR-10-1
96001-11 full track, unmounted, ¾/7½ ips ..... PR-10-1
96001-01 half track, unmounted, 7½/15 ips ..... PR-10-1
96001-03 half track, unmounted ¾/7½ ips ..... PR-10-1
96000-01 half track stereo, unmounted, 7½/15 ips ..... PR-10-2
96000-03 half track stereo, unmounted, ¾/7½ ips ..... PR-10-2



AMPEX MODEL 601—professional field recorder/reproducer to meet the high quality recording and playback needs of broadcasters, industrial and business users, audio-visual and educational applications.

AMPEX MODEL 601-2—stereophonic recorder/reproducer with separate, full-track erase, two-track record and two track playback heads provide for—recording of stereo and single-channel tape (one direction); reproduction of stereo, full or half-track tapes—separate mixing controls for each channel (Microphone and Line) provide for balancing and mixing two-channel input for best combined sound.

## SPECIFICATIONS

FREQUENCY RESPONSE: ±2 db, 40-10,000 cps at 7½ ips. Down no more than 4 db at 30 and 15,000 cps at 7½ ips.

SIGNAL-TO-NOISE: Over 55 db full track, 50 db half-track or two-track at 7½ ips.

FLUTTER AND WOW: Below 0.17% (by ASA standards) at 7½ ips.

TIMING ACCURACY: ±0.2% (±3.6 seconds for 30 minutes).

## ORDERING INFORMATION

652 Portable, half track, 7½ ips, 60 C ..... 601PF	Model 601-2
654 Portable, full track, 7½ ips, 60 C ..... 601PF	
662 Unmounted, half track, 7½ ips, 60 C ..... 601UF	
664 Unmounted, full track, 7½ ips, 60 C ..... 601UF	
656 Portable, half track, ¾ ips, 60 C ..... 601PS	
Plug-in transformer, for low impedance input for Ampex 601 ..... 860	
Adapter panel, for rack mounting for Ampex 601 ..... 861	



Model 601



Model 601-2

AMPEX MODEL 620 AMPLIFIER/SPEAKER—a portable amplifier/speaker designed primarily for use with Model 601 and 601-2 recorders to provide a complete monitoring and playback system.

## SPECIFICATIONS

OUTPUT: 10 watts nominal, 20 watts peak.

INPUT: 0.18 volts to develop rated power.

SYSTEM RESPONSE: 65-10,000 cps, essentially flat.

SIGNAL-TO-NOISE: 70 db below rated output.

## ORDERING INFORMATION

Amplifier-speaker, portable, matches Ampex 601 ..... 620P



# PROFESSIONAL TAPE RECORDERS

## Magnecord PT63 Series

For faithfully recording and reproducing any frequency in the audio range, the Magnecord PT63 has won nation-wide popularity, as well as for its longevity and dependability in service. Separate erase, record playback heads allow monitoring from the tape. Full or half-track heads should be specified as desired. Two-speed motor and capstan change give speeds of  $3\frac{3}{4}$  and  $7\frac{1}{2}$  ips or  $7\frac{1}{2}$  and 15 ips. Frequency

response is from 50 to 15,000 cycles  $\pm 2$  db at 15 ips.

The popular and versatile PT63-J Amplifier Unit combines separate record and playback amplifiers, with a full 10 watts of audio power. Five-inch monitor speaker as well as outlet for connecting external speaker. Three inch VU meter for bias record and playback. Microphone input 50 or 250 ohms balanced or unbalanced. Bridge input, unbalanced. Switch for equalization of 15 and  $7\frac{1}{2}$  ips ( $3\frac{3}{4}$  ips equalizer available at additional charge). Phone jack from tape or input. Line output, 600 ohms 12 dbm balanced; speaker output, 4 or 16 ohms, 10 watts.



### ORDERING INFORMATION

Basic recorder in portable carrying case.....	PT63-A2HZ
Recorder less case.....	PT63-A2HZX
Case.....	91X3318
Record-playback amplifier in case. Includes connector cables.....	PT63-J
Same, less case.....	PT63-JX
Case.....	91X1890

## Magnecord PT6 Series

The PT6-6AJ has through long, hard hours of operation proven itself to be the work horse of the industry. A new, 19" front panel allows the PT6-6 to be rack mounted as well as carried in a portable case. Housed in two separate cases for convenience, the PT6-6 becomes the most practical professional portable in the field.

### SPECIFICATIONS

**FREQUENCY RESPONSE:** 50 to 15,000 cps  $\pm 2$  db at 15 ips. 50 to 7,500 cps  $\pm 2$  db at 7.5 ips.  
**INPUT LEVEL:** Sensitivity—105 dbm for zero level recording. Maximum level—35 dbm.  
**INPUT IMPEDANCE:** 50 ohm balanced. High impedance bridge (phone jack).  
**SIGNAL TO NOISE RATION:** 50 db.  
**TOTAL HARMONIC DISTORTION:** 10 watts out, less than 2%.  
**FLUTTER:** .3% at 15 ips. .5% at  $7\frac{1}{2}$  ips.  
**DIMENSIONS:** Amplifier—8" deep, 7" high, 19" wide without carrying case. 13" deep, 8" high, 20" wide with carrying case.  
**WEIGHT:** Amplifier—21 lbs. with carrying case.  
**TRANSPORT:** 26 lbs. in case.

### ORDERING INFORMATION

Recorder Less Case.....	PT6-6A
Recorder in Case.....	PT6-6AX
Carrying Case for Recorder.....	91X1896
Record/Playback Amplifier in Case.....	PT6-6J
Record/Playback Amplifier less Case.....	PT6-6JX
Amplifier Case.....	91X1890



## Magnecord Models 728 and 748

Recording perfection and brilliant reproduction are combined in this portable Magnecord, the professional model 728. For stereophonic recording, Model 748.

### SPECIFICATIONS

**TAPE SPEEDS:** Two speeds, direct drive,  $7\frac{1}{2}$  ips and 15 ips or  $3\frac{3}{4}$  ips and  $7\frac{1}{2}$  ips available.  
**TIMING ACCURACY:**  $\pm 3$  sec. in 30 minutes.  
**FREQUENCY RESPONSE:** 30 to 18,000 cps,  $\pm 2$  db at 15 ips.  
**FLUTTER AND WOW:** 0.1% at 15 ips; 0.15% at  $7\frac{1}{2}$  ips.

**REEL SIZE:** Up to  $10\frac{1}{2}$  inches NAB.

**PANEL SIZE:**  $17\frac{5}{8}$ " wide x  $12\frac{7}{8}$ " high.

### ORDERING INFORMATION

Magnecord Recorder.....	Model 728
Magnecord Recorder for Stereo.....	Model 748



# PROFESSIONAL TAPE RECORDERS

## Magnecord Model P75

The Magnecord P75-AC simplifies professional work in many ways. For editing, merely open the head cover and move the tape for marking or cutting. Perfect cueing at all times in one easy operation by manually moving the tape over the heads while the tape lifter knob is in manual cueing position. Instant starting with direct drive dual-speed hysteresis synchronous individual reel drive motors.



### SPECIFICATIONS

**TAPE SPEEDS:**  
7 1/2 ips and 15 ips.  
**STARTING TIME:**  
0.2 second (to normal forward).  
**SIGNAL-TO-NOISE RATIO:**  
55 db based upon 3% total harmonic distortion point (full-track).  
**WOW AND FLUTTER:**  
Less than 0.2% at 15 ips; 0.25% at 7 1/2 ips.  
**OUTPUT:**  
600-ohm balanced or unbalanced.  
**OUTPUT LEVEL:**  
+6 dbm when meter indicates 0 VU.

### ORDERING INFORMATION

Record/playback amplifier, less case.  
High impedance input and output for either half or full track transports ..... P75-CX  
Case for P75-AX series ..... 91C1919  
Full track tape transport, less case, 7 1/2 / 15 ips (two speed motor) 60 cycles ..... P75-AX  
Half track tape transport, less case, 7 1/2 / 15 ips (two speed motor) 60 cycles ..... P75-AX-1

## Magnecord S36-B

Here is a widely used professional tape recorder in the low priced field for real commercial results. Single unit has Hi-Z microphone and unbalanced bridging input. Playback amplifier output; 600 ohms balanced or unbalanced. Output level; +8 VU. Response, 50-15,000 cycles. Tape speeds, 7 1/2" and 15" by capstan change. Hysteresis synchronous motor drive. Uses 7" reels. Rewinds in 40 seconds. Illuminated VU meter. Wow flutter, 0.3%. Full track NAB response. Panel 7" x 19" for rack mounting.



### ORDERING INFORMATION

Tape recorder rack mount ..... S36-BX  
Same as above in portable carrying case ..... S36-B

## Recording Tape

(Minnesota Mining and Mfg. Co.)

Recording tape is carried in generous quantity at all Gates stock carrying points. Rapid turnover assures fresh stock at all times. *Recording tape is prepaid to any place in the United States* and quantity prices are lower (see price list). Unless otherwise stated, all tape is of Minnesota Mining manufacture.

SIZE	CAT. NO.
Type 111 plastic base, red oxide coating:	
1/4" x 150' plastic 3" reel	111-1.5
1/4" x 600' plastic 5" reel	111-6
1/4" x 1200' plastic 7" reel	111-12
1/4" x 2400' on hub	111-24H
1/4" x 2400' on 10 1/2" metal reel	111-24R
Type 120 high output plastic base, green coded:	
1/4" x 600' plastic 5" reel	120-6
1/4" x 1200' plastic 7" reel	120-12
Type 190 new thin type, 50% more recording time per reel:	
1/4" x 900' plastic 5" reel	190-9
1/4" x 1800' plastic 7" reel	190-18
1/4" x 3600' NARTB 10 1/2" metal reel	190-36R
1/4" x 3600' on hub	190-36H

Type 150 weather balanced extra play:	
1/4" x 900' on 5" plastic reel	150-9
1/4" x 1800' on 7" plastic reel	150-18
1/4" x 3600' on hub	150-36H
1/4" x 3600' on 10 1/2" metal reel	150-36R
New 200 Double Play Tape:	
1/4" x 1200' on 5" reel	200-12
1/4" x 2400' on 7" reel	200-24
Special Tapes:	
Splicing tape 1/2" x 150'	41-1/2S
Leader timing tape, 1/4" x 150'	43-1.5
Head alignment tape 15" sec.	832
Head alignment tape 7 1/2" sec.	830
Empty Reels with Mailing Cartons:	
3" empty reel	RB-3
4" empty reel	RB-4
5" empty reel	RB-5
7" empty reel	RB-7
10 1/2" empty reel aluminum NAB	RB-10-1/2M
10 1/2" empty reel plastic opaque	RB-10-1/2RBS

Quantity prices shown on price list —  
all tape prepaid anywhere in U.S.A.



# INDEX

Item	Page	Item	Page
AM Transmitters	2 thru 17	Feed-Thru Bowls	60
Ambassador Audio Control Console	72	Field Intensity Meter	50
Amplifier, Cueing	112	Filter Capacitors	59
Amplifier, Equalized Pre	92	Flashers	61
Amplifier, Limiting	107	FM Exciter	30
Amplifier, Monitoring	101, 103, 112	FM Stereo Generator	30
Amplifier, Pre	100, 103	FM Subcarrier Generator	30
Amplifier, Program	101, 103, 112, 116	FM Ring Antenna	31
Amplifier, Linear	42	FM Transmitters	18 thru 29
Amplifier, Transistor Plug-in Audio System	100	Frequency Monitor, AM	46
Amplifier, Tube Plug-in Audio System	103	Frequency Monitor Extension Unit	54
Amplifier, 3-stage Pre	116	Frequency Monitor, FM	50
Amplifier, Transistor Utility Monitor	102		
Antenna Couplers	44	Gain and Measuring Set	118
Antenna Diode Units for Remote Control	45, 54	Gatesway Audio Control Console	77
Antennas, Dummy	55	Gauge, Stylus	123
Antenna for FM	31	Generating Plants, AC	123
Arms, Pickup	91	Ground; Rods, Screen, Strap, Wire	61
Audio Consoles	62 thru 87		
Audio Oscillator	118	Headphones	122
Audio Terminal Block	123	Horn Gaps	60
Automatic Program Level Amplifier (Sta-Level)	109	Horseshoe Desk, CB-4	93
Automatic Programming Equipment	99		
Average Level Amplifier (Level Devil)	110	Inductors	58
Baffles, Wall	121	Jack Panels	117
Biamote, 2-Channel Remote Amplifier	114		
Bowls, Feed-Thru	60	Level Devil Amplifier	110
Broadcast Transmitters, AM, FM, TV	2 thru 37	Lights, Studio Warning	122
		Lights, Tower	61
Cabinet, Disc	123	Limiting Amplifier	105, 107
Cabinet, Rack	119	Linear Amplifiers	42
Cable, Microphone	123	Loudspeaker Matching Transformer	121
Cable, Studio	123	Loudspeakers	121
Capacitors, Filter	59		
Capacitors, Mica	59	Meters	45
Cartridges, Pickup	92	Meter, Distortion	118
Cartridges for Cartritone Unit	98	Meter Extension Kits for Remote Control	45, 54
Cartritone (Cartridge Tape Systems)	94, 97	Mica Capacitors	59
Center Post Insulator	60	Microphone Accessories	122
Chokes, Tower	45	Microphone Cable	123
Clocks, Studio	122	Microphone Connectors, Cannon	123
Coaxial Cable	61	Microphones	120
Coils, Isolation	45	Microphone Stands	122
Communications, Transmitter/Receiver	42	Modulation Monitor, AM	47
Console, Sound Effects	87	Modulation Monitor, Deluxe	49
Consoles, Speech Input	62 thru 87	Modulation Monitor, Shortwave	49
Console, Transmitter Control	50	Monitor, FM	50
Couplers, Antenna	44	Monitor, Frequency	46
Cueing Amplifiers	112	Monitor, Modulation	47, 49
		Monitor, Phase	50
Desks for Consoles and Turntables	93	Monitor, Video	38
Dial, Counter Type	58	Monitoring Amplifiers	101, 102, 103, 112
Diplomat Audio Control Console	66	Multiplex for FM Transmitters	30
Directional Phasors	43		
Disc Cabinets	123	Nite-Watch Automatic Programming Equipment	99
Distortion Meter	118		
Dual Peak Limiting Amplifier	105	Open Wire Transmission Line	60
Dualux Audio Control Console	75	Oscillator, Audio	118
Dummy Antennas	55		
Dynamote 4-Channel Remote Amplifier	113	Panel and Shelf Assemblies	102, 104
		Patch Cords	38, 117
Equalized Preamplifiers	92	Patch Panels	117
Eraser, Tape	123	Patch Panels, Video	38
Executive Audio Control Console	62	Phase Monitor	50

Item	Page	Item	Page
Phase Sampling Loops	45	Tower Light Flashers, Lights, Photo-Cell Units	61
Phasors, Directional	43	Transmitter/Receiver, Single Sideband	42
Pickup Arms	91	Transcription Pickup Arms	91
Pickup Cartridges, Reluctance	92	Transcription Turntable, CB-500, 16-inch	88
Portable Audio Console (Keldon)	87	Transcription Turntable, CB-510, CB-525, 16-inch	89
Power Supply	101, 104	Transcription Turntable, CB-77, CB-88, CB-880, 12-inch	90
Preamplifiers	92, 100, 103, 116	Transformers	56
Preamplifiers, 3-stage	116	Transformers, Loudspeaker Matching	121
President Audio Control Console	69	Transmission Line	61
Program Amplifiers	101, 103, 112	Transmitters (Broadcast/AM)	
Proof-of-Performance Equipment	118	100,000 Watt Model BC-100C Transmitter	2
		50,000 Watt Model BC-50C Transmitter	4
Rack Cabinets	119	20,000 Watt Model BC-20B Transmitter	7
Receiver/Transmitter, Single Sideband	42	10,000 Watt Model BC-10P Transmitter	8
Recorder, Cartritape	94, 97	5,000 Watt Model BC-5P-2 Transmitter	10
Recorders, Tape	124	1,000 Watt Model BC-1G Transmitter	13
Recording Tape	126	500 Watt Model BC-500G Transmitter	16
Relay Assemblies (Auxiliary) for Remote Control	54	250 Watt Model BC-250GY Transmitter	17
Remote Amplifiers	113 thru 116	Transmitter Control Console	50
Remote Control Accessories	54	Transmitters (Broadcast/FM)	
Remote Control Cartritape	95	20,000 Watt Model FM-20B Transmitter	18
Remote Control System, RDC-10AC	51	10,000 Watt Model FM-10B Transmitter	20
Remote Control System, RDC-200	53	5,000 Watt Model FM-5C Transmitter	22
Remote Metering Kits	45, 54	1,000 Watt Model FM-1C Transmitter	25
Remote Metering Panels	54	250 Watt Model FM-250C Transmitter	27
RF Amplifier for FM Remote Control	54	50 Watt Model BFE-50C Transmitter	29
RF Pickup Coil and Rectifier	118	50 Watt FM Relay, Transmitter, Model BFR-50C	29
Rheostats, Motor Tuned, for Remote Control	54	10 Watt Educational Transmitter, Model BFE-10C	29
Rods, Ground	61	Transmitters (Communications)	
		100,000 Watt High Frequency Broadcast Transmitter	39
Sampling Loops, Phase	45	50,000 Watt High Frequency Broadcast Transmitter	39
Screen, Ground	61	20,000 Watt Model HF-20 Transmitter	40
Single Sideband Amplifiers	42	10,000 Watt Model HF-10 Telephone and Telegraph	
Sound Effects Equipment	87	Transmitters (15-KW Telegraph)	40, 41
Speakers, Loud	121	5,000 Watt Model HF-5 Telephone and Telegraph	
Splicers, Tape	123	Transmitter	41
Sta-Level Amplifier	109	1,000 Watt Model HF-1M Transmitter	41
Stands, Microphone	122	50 Watt FM Relay Transmitter, Model BFR-50C	29
Stereo Audio Control Consoles	62, 79	100 Watt Single Sideband Transmitter/Receiver	42
Stereo Cartridge Tape System	94	Transmitters (Television)	
Stereo Generator	30	5,000 Watt Model BT-5C Transmitter	33
Stereo Limiter	105	500 Watt Model BT-500C Transmitter	35
Stereo Pick-up Cartridges	92	100 Watt Model BT-100C Transmitter	37
Stereo Turntable Package	91	Turntable Equalizer	91
Stereo Turntable Preamplifier	92	Turntable, Transcription	88 thru 90
Strap, Ground	61	TV-10 Audio Control Console	85
Studioette Audio Control Console	83	Twinsistor 2-Channel Transistor Remote	115
Studio Warning Lights	122		
Studio Wire	123	Uni-Cue Cueing Amplifier	112
Stylus Force Gauge	123	Unimote Single Microphone Remote	116
Switch and Fuse Panel	117	Utility Amplifier, Single Microphone	116
Switcher, Cartritape	95		
Tape, Cartridges	98	Video Monitors	38
Tape, Eraser	123	VU Meter Panel	117
Tape, Recording	126		
Tape Recorder, Cartridge (Cartritape)	94, 97	Wall Baffles, Loudspeaker	121
Tape Recorders	124	Wire, Ground	61
Tape Splicers	123		
Television Control Console, Model TV-10	85	Yard Audio Control Console	81
Television Monitors	38	Yard Audio Control Console (Stereo)	79
Television Transmitters	33 thru 37		
Terminal Block, Audio	123		
Tower Chokes	45		

NOTE: All products listed in this catalog are subject to standard improvement.

TYPSET AND LITHOGRAPHED BY LOGAN PRINTING COMPANY, PEORIA, ILLINOIS, ON HARRIS-INTERTYPE EQUIPMENT.



# ORDERING INFORMATION

## ORDER PROCEDURE:

All sales are made in accordance with the standard Gates Terms and Conditions of Sale. No order shall be binding upon Gates until accepted by it in writing at its home office in Quincy, Illinois.

## OUR PRICES:

Catalog prices are net, f.o.b. Quincy, Illinois, or point of shipment. Our prices are based on cash transactions and all applicable discounts have been deducted. Prices are subject to change without notice. Orders are filled at prices in effect at time of shipment. You will be billed for any price increase and credited for any price reduction. We reserve the right to add any federal, state, or local taxes required by law. If you have a tax exemption number, please include it with your order. These prices and terms apply only to the U.S. For prices and terms in other countries, contact our Export Department.

## OUR TERMS:

There are five ways to pay for your equipment purchases:

1. Cash—This means full payment with order.
2. C.O.D.—The amount due is collected by the delivery agent. A 25% down payment is required on C.O.D. orders.
3. Sight draft—Your local bank releases payment to us upon receipt of bill of lading. A 25% down payment is normally required.
4. Open Account—Payment to be remitted by you within 30 days after date of each invoice. This privilege is extended to established accounts with good payment records. If you do not have an established account, please provide a current financial statement, plus trade and bank references with your order. Allow about ten days to process the information.
5. Gates Finance Plan—On major purchases, a portion of the cost may be financed through a monthly payment plan. A finance charge of 6% per annum will be added when the total amount of the order is less than \$4,000.00. On orders of \$4,000.00 or over, the finance charge is 4½% per annum. Title to and/or rights to the merchandise remain with Gates Radio Company until the balance is fully paid. Finance laws vary from state to state, but all states require the execution and acceptance of conditional sales contract, chattel mortgage, notes, or other documentation prior to shipment. You may not sell, remove, or encumber the merchandise covered by such contracts without Gates Radio Company's prior written consent, and you assume all responsibility for loss or damage. Acceptable insurance, with a loss payable clause naming Gates Radio Company, is required for the full term of the contract. Since Gates financing plans are subject to change from time to time, contact our Credit Manager or your nearest Gates Sales Engineer for full information.

## SHIPMENT:

Please specify method of shipment on your order. Shipping charges, insurance, and C.O.D. fees (when applicable) will be collected at time of delivery when shipment is by air, rail or motor freight, or express. If you request parcel post shipment, postage and insurance fees will be billed to your account. Purchaser assumes all responsibility for and risk of loss of, or damage to, equipment upon shipment from Gates shipping point(s).

Should you receive merchandise damaged in shipment, it is your responsibility to file a damage claim immediately with the delivering carrier. Export packing for overseas shipment is available at slight extra charge.

## RETURNS AND EXCHANGES:

Do not return any merchandise without our written approval and Return Authorization. We will provide special shipping labels and a code number that will assure proper handling and prompt issuance of credit. Please furnish a detailed report to assure prompt handling of returned merchandise. Custom built equipment or merchandise specially ordered for you is not returnable. Where return of standard equipment is allowed by Gates, a restocking fee of 15% will be charged. All returned merchandise must be sent freight prepaid and properly insured by the customer. When writing to Gates Radio Company about your order, it will be helpful if you specify the Gates Factory Order Number or Invoice Number.

## WARRANTY ADJUSTMENTS:

In the event of equipment failure during the warranty period, replacement or repair parts may be provided in accordance with the provisions of the Gates Warranty. In most cases you will be required to return the defective merchandise or part to Gates f.o.b Quincy, Illinois, for replacement or repair. Cost of repair parts or replacement merchandise will be billed to your account at the time of shipment and, as to repairs or replacement within warranty, compensating credit will be issued to offset the charge.

## MODIFICATIONS:

Gates reserves the right to modify the design and specifications of the equipment shown in this catalog without notice or to withdraw any item from sale provided, however, that any modifications shall not adversely affect the performance of the equipment so modified.

since

**GATES**

1922

**HOME OFFICE AND  
MANUFACTURING FACILITIES**

QUINCY, ILLINOIS  
123 Hampshire Street  
Phone: 222-8202, Area 217

**STOCK CARRYING BRANCH**

HOUSTON 3, TEXAS  
2700 Polk Avenue  
Phone: CA8-8536, Area 713

**DISTRICT OFFICES**

NEW YORK 10, NEW YORK  
800 Second Avenue  
Phone: MU7-7971, Area 212

LOS ANGELES 7, CALIFORNIA  
1945 S. Figueroa  
Phone: RI7-7129, Area 213

WASHINGTON 4, D. C.  
Warner Building  
13th & E Streets, N.W.  
Phone: ME8-0522, Area 202

**EXPORT SALES**

NEW YORK 16, NEW YORK  
Rocke International Corp.  
13 East 40th Street  
Phone: MU9-0200, Area 212  
Cables: ARLAB

**CANADIAN SALES**

MONTREAL 16, QUEBEC, CANADA  
Canadian Marconi Co.  
90 Trenton Avenue  
Phone: RE8-9441, Area 514

**GATES RADIO COMPANY**

A Subsidiary of Harris-Intertype Corporation

123 Hampshire Street, Quincy, Illinois

QUINCY, ILLINOIS

