



FUNCTION GENERATOR DATA BOOK

First in Quality... First in Service • Custom, Semicustom and Standard IC's

Introduction

This Data Book contains a complete summary of technical information covering Exar's complete line of Voltage-Controlled Oscillator (VCO) and Function Generator IC products. The wide range of applications for each of the products presented in this book will greatly simplify most system designs. To help the designer to find the right devices for his applications, a number of convenient cross-reference charts are also included which show the key features of each of the products discussed, in terms of different classes of applications.

EXPERIENCE AND PRODUCTS

Exar's innovativeness, product quality and responsiveness to customer needs have been the key to its success. Exar today offers a broad line of linear and interface circuits. In the field of standard linear IC products, Exar has extended its circuit technological leadership into the areas of communications and control circuits. Today Exar has one of the most complete lines of IC oscillators, timing circuits and phase-locked loops in the industry. Exar also manufactures a large family of telecommunication circuits such as tone decoders, companders, modulators, PCM repeaters and FSK Modem Circuits. In the field of industrial control circuits, Exar manufactures a broad line of quad and dual operational amplifiers, voltage regulators, radio-control and servo driver IC's, and power control circuits.

Exar's experience and expertise in the area of bipolar IC technology extends both into custom and standard IC products. In the area of custom IC's, Exar has designed, developed, and manufactured a wide range of full-custom monolithic circuits, particularly for applications in the areas of telecommunication, consumer electronics, and industrial controls.

In addition to the full-custom capability, Exar also offers a unique semi-custom IC development capability for low to medium-volume custom circuits. This semi-custom program, is intended for those customers seeking cost-effective solutions to reduce component count and board size in order to compete more effectively in a changing marketplace. The program allows a customized monolithic IC to be developed with a turnaround time of several weeks at a small fraction of the cost of a full-custom development program.

EXCELLENCE IN ENGINEERING

Exar quality starts in Engineering where highly qualified people are backed up with the advanced instruments and facilities needed for design and manufacture of custom, semi-custom and standard integrated circuits. Exar's engineering and facilities are geared to handle all three classes of IC design: (1) semi-custom design programs using Exar's bipolar and I²L master chips; (2) full-custom IC design; (3) development and high-volume production of standard products.

Exar reserves the right to make changes at any time in order to improve design and to supply the best product possible.

Some of the challenging and complex development programs successfully completed by Exar include analog companders and PCM repeaters for telecommunication, electronic fuel-injection, anti-skid braking systems and voltage regulators for automotive electronics, digital voltmeter circuits, 40-MHz frequency synthesizers, high-current and high-voltage display and relay driver ICs, and many others.

NEW TECHNOLOGIES

Through company sponsored research and development activities, Exar constantly stays abreast of all technology areas related to changing customer needs and requirements. Exar has recently completed development efforts in Integrated Injection Logic (I²L) technology, which offers unique advantages in the area of low-power, high-density logic arrays. Exar has a complete design engineering group dedicated to this new technology, and is currently supplying over twenty different custom and semi-custom I²L products.

FIRST IN QUALITY

From incoming inspection of all materials to the final test of the finished goods, Exar performs sample testing of each lot to ensure that every product meets Exar's high quality standards. Exar's manufacturing process is inspected or tested in accordance with its own stringent Quality Assurance Program, which is in compliance with MIL-Q-9858A. Additional special screening and testing can be negotiated to meet individual customer requirements.

Throughout the wafer fab and assembly process, the latest scientific instruments, such as scanning electron microscopes, are used for inspection, and modern automated equipment is used for wafer probe, AC, DC, and functional testing. Environmental and burn-in testing of finished products is also done in-house. For special environmental or high reliability burn-in tests outside testing laboratories are used to complement Exar's own extensive in-house facilities.

FIRST IN SERVICE

Exar has the ability and flexibility to serve the customer in a variety of ways from wafer fabrication to full parametric selection of assembled units for individual customer requirements. Special marking, special packaging and military screening are only a few of the service options available from Exar. We are certain that Exar's service is flexible enough to satisfy 99% of your needs. The company has a large staff of Applications Engineers to assist the customer in the use of the product and to handle any request, large or small.

Exar cannot assume responsibility for any circuits shown or represented, as being free from patent infringement.

Table of Contents

	Page
Fundamentals of Monolithic Waveform Generation and Shaping	2
Overview of Exar's Oscillator Products	4
Choosing the Right Oscillator	6
Quality Assurance Standards	9
XR-205 Monolithic Waveform Generator	10
XR-2206 Monolithic Function Generator	14
XR-2207 Voltage Controlled Oscillator	18
XR-2209 Precision Oscillator	26
XR-8038 Precision Waveform Generator	30
AN-01 Application Note Stable FSK MODEMs Featuring the XR-2207, XR-2206 and XR-2211	34
AN-06 Application Note Precision PLL System Using the XR-2207 and the XR-2208	39
AN-14 Application Note A High Quality Function Generator System Using the XR-2206	42
AN-15 Application Note An Electronic Music Synthesizer Using the XR-2207 and the XR-2240	46
Monolithic Chips for Hybrid Assemblies	48
Product Ordering Information	51
Foreign Sales Offices and Representatives	52
Authorized Stocking Distributors	53
Authorized Representatives	54

Fundamentals of Monolithic Waveform Generation and Shaping

Waveform or function generators find a wide range of applications in communications and telemetry equipment, as well as for testing and calibration in the laboratory. In most of these applications, commercially-available monolithic IC oscillators and function generators provide the system designer with a low-cost alternative to conventional, non-integrated units costing several hundred dollars or more.

The fundamental techniques of waveform generation and shaping are well suited to monolithic IC technology. In fact, monolithic integrated circuits offer some inherent advantages to the circuit designer, such as the availability of a large number of active devices and close matching and thermal tracking of integrated components and the batch-processing advantages of monolithic circuits, it is now possible to design integrated waveform generator circuits that can provide a performance comparable to that of complex discrete generators, at a very small fraction of the cost. This article provides a brief review of the fundamental principles of monolithic waveform generation and wave-shaping methods.

Basics of IC Waveform Generation

Essentially a waveform generator is a stable oscillator circuit that outputs well-defined waveforms; and, these can be externally modulated or swept over a frequency range. A waveform generator usually consists of four sections: (1) an oscillator to generate the basic periodic waveform; (2) a wave-shaper; (3) an optional modulator section to provide AM capability, and (4) an output buffer amplifier to provide the necessary load drive.

Figure 1 shows a simplified generator using the four functional blocks. Each block can be built readily in monolithic form with established linear IC technology. Hence fabrication of all four blocks on a single monolithic chip has evolved as a natural extension of earlier circuits.

The oscillator, usually a relaxation type, can generate linear, triangle or ramp waveforms. The usual technique involves constant-current charging and discharging of an external timing capacitor. Figure 2 shows a typical, though simplified, example: an emitter-coupled multivibrator circuit, which can generate a square wave as well as a triangle or a linear ramp output.

The circuit's operation is as follows: At any given time, either Q_1 and D_1 or Q_2 and D_2 are conducting such that capacitor C_0 is alternately charged and discharged by constant-current I_1 . The output across D_1 and D_2 corresponds to a symmetrical square wave, having a pk-pk amplitude of $2V_{BE}$, or twice the transistor base-emitter voltage drop. Output V_A , constant when Q_1 is on, becomes a linear ramp with a slope equal to $-I_1/C_0$ when Q_1 goes off. Except for a half cycle delay, output $V_B(t)$ is the same as $V_A(t)$.

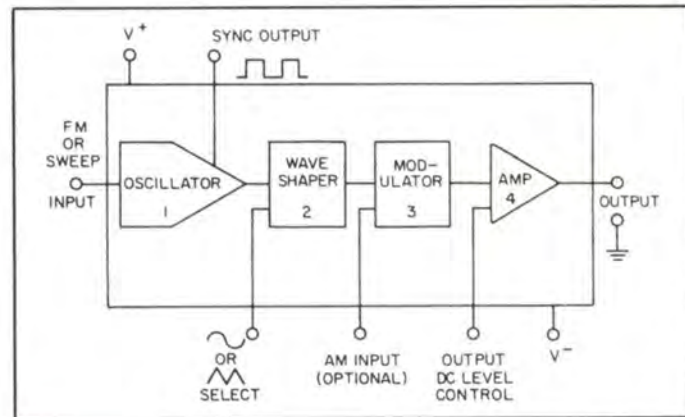

Figure 1. Basically, a waveform generator consists of four sections. Each section can be built readily in monolithic form with established IC technology.

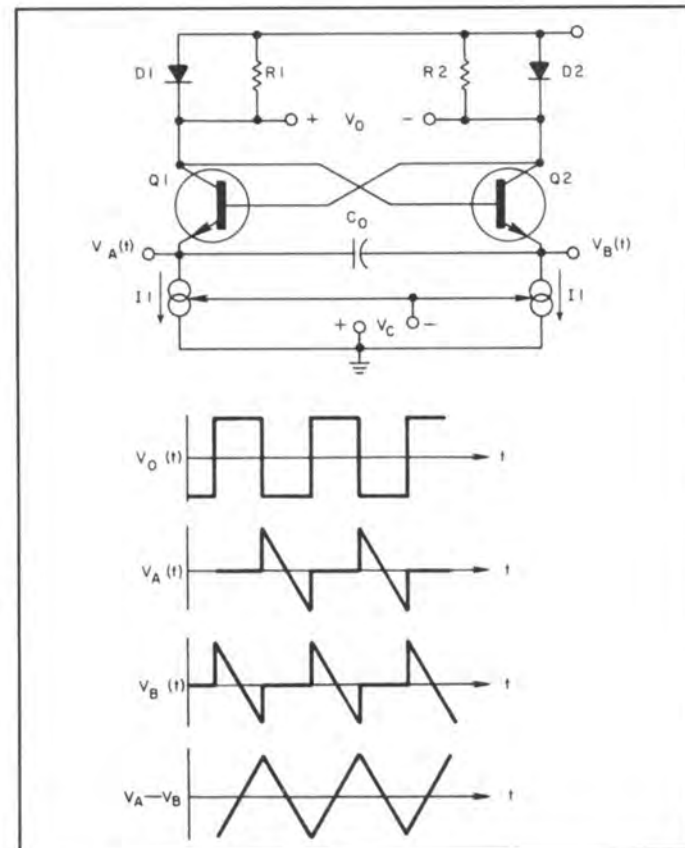

Figure 2. A simple oscillator circuit can be used to generate square, ramp and triangle waveforms.

Both linear ramp waveforms have pk-pk amplitudes of $2V_{BE}$. Their frequency of oscillation, f_0 , can be determined from the formula

$$f_0 = \frac{I_1}{4V_{BE}C_0}$$

And f_o can be controlled by variation of charging-current I_1 via control voltage V_C . A subtraction of one output ramp voltage from the other, by use of a simple differential amplifier, obtains the linear triangular waveform.

Symmetry of triangle and square-wave outputs may be adjusted by replacement of one of the two current sources in Figure 2 by I_2 , where $I_2 \neq I_1$. Then the duty cycle of the output waveforms becomes the following:

$$\text{Duty Cycle} = 50 \frac{I_1}{I_2} \%$$

The duty cycle of the output may be varied over a wide range by varying the ratio of the currents I_1 and I_2 .

Wave-Shaping Techniques

The most useful waveform in signal processing applications is the sine wave. In the design of function generators, sinusoidal output is normally obtained by passing a triangular wave through a wave shaping circuit. In most discrete-component generators, wave-shaping involves a diode-resistor or a transistor-resistor ladder network. Introduction of a finite number of "break points" on the triangle wave changes it to a low distortion sine wave.

Although this method can also be adapted to monolithic circuits, it is not as practical because it requires extremely tight control of resistor values and diode characteristics. A simpler, and more practical, sine shaper for monolithic circuits employs the "gradual cutoff" characteristics of a basic differential gain stage, as in Figure 3.

Reduction of the emitter-degeneration resistance, R_E , allows either transistor Q_3 or Q_4 to be brought near their cutoff

point when the input triangle waveform reaches its peaks. For the proper choice of the input amplitude and bias-current levels, the transfer characteristics at the peaks of the input triangle waveform become logarithmic rather than linear. Thus, the peaks of the triangle become rounded, and the output appears as a low distortion sine wave.

Use of this technique permits output harmonics to be reduced to less than 0.5% with only a single adjustment. The low distortion is possible because the technique relies on component matching rather than their absolute values. Since monolithic ICs can be designed readily for close matching, this wave-shaping is ideally suited to monolithic design.

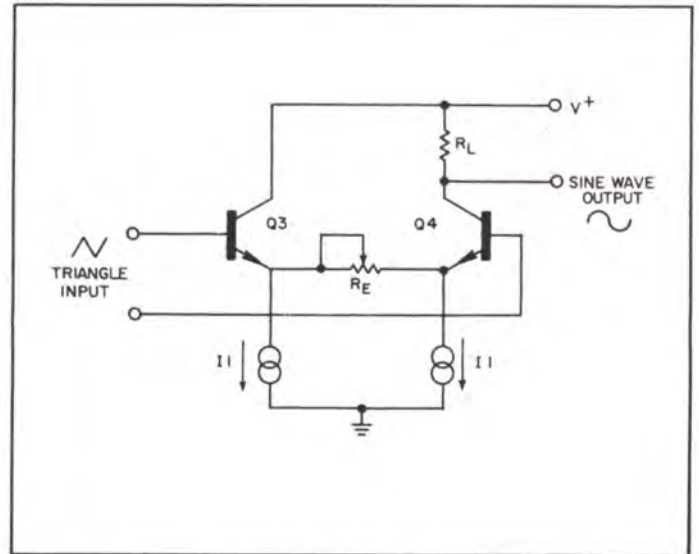

Figure 3. Conversion of triangle to sine wave employs a differential gain stage, which avoids dependence on absolute values of components.

Overview of Exar's Oscillator Products

Exar offers the widest selection of monolithic IC oscillators or waveform generators available in the industry. Starting with the low-cost, easy-to-use XR-2209 precision oscillator, and extending to the high-performance XR-2206 function generator, this wide choice of products covers a very broad range of applications. This section of Exar's IC Oscillator Data Book is intended to provide the user with a brief but complete overview of Exar's family of monolithic IC oscillators. The key features of each of these circuits are briefly described below:

XR-205 Monolithic Waveform Generator

The XR-205 is a highly versatile, monolithic waveform generator designed for diverse applications in communication and telemetry equipments, as well as in systems design and testing. It is a self-contained, totally monolithic signal generator that provides sine, square, triangle, ramp and sawtooth output waveforms, which can be both amplitude and frequency modulated. It offers the following performance features:

- High Frequency Capability (to 4 MHz)
- Wide Supply Range (+8V to +26V)
- Output Current Swing of ± 10 mA
- Frequency Sweep Range of 10:1, Typ.
- Amplitude Modulation Capability

XR-2206 Monolithic Function Generator

The XR-2206 is a monolithic function generator integrated circuit capable of producing high quality sine, square, triangle, ramp and pulse waveforms of high stability and accuracy. The output waveforms can be both amplitude and frequency modulated by an external voltage. Frequency of operation can be selected externally over a range of 0.01 Hz to more than 1 MHz.

This circuit is ideally suited for communications, instrumentation, and function generator applications requiring sinusoidal tone, AM, FM, or FSK generation. It has a typical drift specification of 20 ppm/ $^{\circ}$ C. It has the following important features:

- Low Sinewave Distortion (THD .5%)—
Insensitive to Signal Sweep
- Excellent Stability (20 ppm/ $^{\circ}$ C, Typ.)
- Wide Sweep Range (2000:1, Typ.)
- Low Supply Sensitivity (0.01%/V, Typ.)
- Linear Amplitude Modulation
- Adjustable Duty-Cycle (1% to 99%)
- TTL Compatible FSK Controls
- Wide Supply Range (10V to 26V)

XR-2207 Voltage-Controlled Oscillator

The XR-2207 is a monolithic voltage-controlled oscillator (VCO) integrated circuit featuring excellent frequency stability and a wide tuning range. The circuit provides simultaneous triangle and square wave outputs over a frequency range of 0.01 Hz to 1 MHz. It is ideally suited for FM, FSK, sweep or tone generation, and phase-locked loop applications. Its performance features are summarized below:

- Excellent Temperature Stability (20 ppm/ $^{\circ}$ C)
- Linear Frequency Sweep
- Adjustable Duty Cycle (0.1% to 99.9%)
- Two or Four Level FSK Capability
- Wide Sweep Range (1000:1 Min.)
- Logic Compatible Input and Output Levels
- Wide Supply Voltage Range (± 4 V to ± 13 V)
- Low Supply Sensitivity (0.15%/V)
- Wide Frequency Range (0.01 Hz to 1 MHz)
- Simultaneous Triangle and Square Wave Outputs

XR-2209 Precision Oscillator

The XR-2209 is a monolithic variable frequency oscillator circuit featuring excellent temperature stability and a wide linear sweep range. The circuit provides simultaneous triangle and square wave outputs over a frequency range of 0.01 Hz to 1 MHz. The frequency is set by an external RC product. It is ideally suited for frequency modulation, voltage-to-frequency or current-to-frequency conversion, sweep or tone generation as well as for phase-locked loop applications when used in conjunction with a phase comparator such as the XR-2208.

The circuit is comprised of three functional blocks: a variable frequency oscillator, and two buffer amplifiers for the triangle and square wave outputs. It is basically a simplified version of the XR-2207 oscillator, with the FSK controls removed. It has the following features:

- Excellent Temperature Stability (20 ppm/ $^{\circ}$ C)
- Linear Frequency Sweep
- Wide Sweep Range (1000:1 Min.)
- Wide Supply Voltage Range (± 4 V to ± 13 V)
- Low Supply Sensitivity (0.15%/V)
- Wide Frequency Range (0.01 Hz to 1 MHz)
- Simultaneous Triangle and Square Wave Outputs
- Easy-to-Use 8-Pin Package

XR-8038 Precision Waveform Generator

The XR-8038 is a precision waveform generator IC capable of producing sine, square, triangular, sawtooth and pulse waveforms with a minimum of external components and adjustments. Its operating frequency can be selected over nine

decades of frequency, from 0.001 Hz to 1 MHz, by the choice of external RC components. The frequency of oscillation is highly stable over a wide temperature and supply voltage range. The frequency modulation and sweeping can be accomplished with an external control voltage without affecting the quality of the output waveforms; and the frequency can be programmed digitally through the use of either resistors or capacitors. It has the following features:

Direct Replacement for Intersil I8038
 Low Frequency Drift—50 ppm/°C

Simultaneous Sine, Triangle and Square Wave Outputs
 Low Distortion—THD 1%
 High FM and Triangle Linearity
 Wide Frequency Range—0.001 Hz to 1 MHz
 Minimum External Component Count
 Variable Duty-Cycle—2% to 98%

Table 1 gives a summary and a comparative listing of the electrical characteristics of each of these monolithic oscillator or function generators described above.

TABLE 1
 Summary of Electrical Characteristics of Exar's Oscillator IC's

Electrical Characteristics	Device Type				
	XR-205	XR-2206	XR-2207	XR-2209	XR-8038
Supply voltage range (single supply)	8 to 26 V	10 to 26 V	8 to 26 V	8 to 26 V	10 to 30 V
Output waveforms	Triangle square sine	Triangle square sine	Triangle square	Triangle square	Triangle square sine
Upper frequency limit (MHz)	4	1	1	1	1
Temperature drift (ppm/°C)	300 (typ)	50 (max)	50 (max)	50 (max)	50 (max)
Power supply drift (%/V)	0.5 (max)	0.05 (max)	0.15 (typ)	0.15 (typ)	0.1 (typ)
Frequency sweep range	7:1	2000:1	1000:1	1000:1	1000:1
Duty cycle adjustment range	10-90%	1-99%	1-99%	1-99%	2-98%
FM nonlinearity ($\Delta f = \pm 10\%$)	0.2%	0.1%	0.1%	0.1%	0.1%
Sine-wave distortion untrimmed trimmed	3.5% 2.5%	1.5% 0.5%	— —	— —	0.7% 0.5%
Output amplitude, ($V^+ = 12V$) sine wave (V pk-pk) triangle wave (V pk-pk)	3 2.5	6 6	— 6	— 6	2.5 4
Triangle nonlinearity	1%	0.2%	0.5%	0.5%	0.05%
Output impedance (ohms) sine/triangle output	50	600	10	10	200
Package type	16-pin DIP	16-pin DIP	14-pin DIP	8-pin DIP	14-pin DIP

Choosing The Right IC Oscillator

At the onset of his design, the user of monolithic oscillator products is faced with the key question of choosing the oscillator or the function generator best suited to his application. The broad line of function generator products offered by Exar covers a wide range of applications. It is often difficult to determine at a glance the best circuit for a given application. The purpose of this section is to review some of the key performance requirements, from an applications point of view, and help answer the question, "What is the best IC oscillator for the job?" Table 2 presents an application-oriented listing of the performance characteristics of Exar's broad line of IC oscillators to assist the user in choosing the most suitable and economical product for his application.

Sine Wave Generation

In evaluating the output characteristics of sinusoidal IC oscillators, total harmonic distortion (THD) of the output waveform is usually the key performance criteria. In a number of voice-grade telecommunication or laboratory applications, sine wave distortion of 2% to 3% may be tolerable. However, for audio-quality signals, a distortion level of 1% or less is required. Furthermore, it is desirable that the output distortion should be relatively independent of the output amplitude, frequency or temperature changes; and that the distortion level be minimized with a minimum amount of external adjustments.

Exar manufactures three separate families of IC oscillators which provide sinusoidal output waveforms. These are the XR-205, XR-2206 and the XR-8038. All of these circuits require external trimming to minimize the output distortion. In the case of XR-205, the untrimmed distortion is about 5%; in the case of the XR-2206 and the XR-8038, untrimmed distortion is typically less than 2%, and can be reduced to 0.5% with additional trimming.

For low frequency sine wave generation (below 100 kHz), the XR-2206 and the XR-8038 are the recommended circuits. The XR-8038 has a fixed output level, whereas the XR-2206 offers separate output dc level and amplitude adjustment capability.

AM Generation

Linear modulation of output amplitude by means of an analog control signal is a desirable feature for telemetry and data transmission applications. In monolithic IC oscillators, this capability is normally obtained by including a four-quadrant transconductance multiplier on the IC chip. Both the XR-205 and the XR-2206 circuits have such a feature included on the chip and can be used for generating sinusoidal AM signals.

They can operate both in suppressed-carrier or conventional double-sideband AM generator mode. For operation with frequencies below 100 kHz, the XR-2206 has superior performance characteristics over the XR-205.

FM Generation

Essentially all of Exar's IC oscillator circuits described in Table 2 can be used for generating frequency-modulated waveforms. For small frequency deviations (i.e., $\pm 5\%$ or less) about the center frequency, all of these oscillators have FM non-linearity of 0.1% or less. However, if wider FM deviations are required the XR-2209, XR-2207 and the XR-2206 offer the best FM linearity.

FSK Generation

Frequency-shift keying (FSK) is widely used in digital communications, particularly in data-interface or acoustical-coupler type MODEM systems. In monolithic IC oscillators, FSK capability is obtained by using a current-controlled oscillator and keying its control current between two or more programmed levels which are set by external resistors. This results in output waveforms which are phase-continuous during the frequency transitions between the "mark" and "space" frequencies.

The XR-2207 can produce four discrete frequencies, set by one external capacitor and four setting resistors. Frequency keying between these four frequencies is achieved by a two-bit binary logic input. The circuit produces both triangle and square wave outputs. The XR-2206 produces two discrete frequencies, f_1 and f_2 , and has a one-bit keying logic input. The key advantage of XR-2206 over the XR-2207 in FSK MODEM design is the availability of a sinusoidal output waveform.

Exar has compiled a comprehensive application note describing the use of both of these IC products in the design of FSK MODEM systems. This application note entitled "Stable FSK MODEMs Featuring the XR-2207, XR-2206 and the XR-2211" is also included in this Data Book.

Laboratory Function Generator

One of the main applications for oscillators is for laboratory or test instrumentation or calibration where a variety of different output waveforms are required. Most such applications require both AM/FM modulation capability, linear frequency sweep and sinusoidal output. Among the IC products outlined

in Table 2, the circuit which fits this application best is the XR-2206 since it has all the fundamental features of a complete function generator system costing upwards of several hundred dollars.

A comprehensive description of building a self-contained laboratory-quality function generator system using the XR-2206 is given in Exar's Application Note AN-14 which is included in this Data Book.

Phase-Locked Loop Design

The current-controlled or voltage-controlled oscillator (VCO) is one of the essential components of a phase-locked loop (PLL) system. The key requirement for this application is that the oscillator should have a high degree of frequency stability and linear voltage or current-to-frequency conversion characteristics. Sinusoidal output, although often useful, is generally not required in this application.

Although all of Exar's IC oscillators can be used as a VCO in designing PLL systems, the XR-2207 or its low-cost and simplified version, the XR-2209, are often the best suited devices for this application. For additional information, the reader is referred to Exar's Application Note AN-06, entitled "Precision PLL System Using the XR-2207 and the XR-2208," which is included in this Data Book.

Sweep Oscillator

A sweep oscillator is required to have a large linear sweep range. Among Exar's function generators, the XR-2207 and the XR-2206 have the widest linear sweep range (over 1000:1), and are best suited for such an application.

By using a linear ramp output from the XR-2207 to sweep the frequency of the XR-2206, one can build a two-chip sweep oscillator system which has a 2000:1 sweep range and sinusoidal output.

Low-Cost General Purpose Oscillator

In many digital design applications, one needs a stable, low-cost oscillator IC to serve as the system clock. For such applications, the XR-2209 precision oscillator is a logical design choice since it is a simple, low-cost oscillator circuit and offers 20 ppm/°C frequency stability.

The monolithic timer circuits, such as the XR-555, or its micro-power version, the XR-L555, can also be used as low-cost, general purpose oscillators by operating them in their free-running, i.e., self-triggering, mode.

Ultra-Low Frequency Oscillator

In certain applications such as interval-timing or sequencing, stable, ultra-low frequency oscillators which can operate at frequencies of 0.01 Hz or lower are required. Among Exar's oscillator circuits, the IC most suited to such an application is the XR-8038 since it can operate with a polarized electrolytic capacitor as its timing component. All other oscillator circuits described in this book require non-polar timing capacitors, and therefore are not as practical as the XR-8038 for ultra-low frequency operation.

An alternate approach to obtaining stable ultra-low frequency oscillations is to use the XR-2242 counter/timer as an oscillator in its free-running mode. Such a circuit generates a square wave output with a frequency of $(1/256 RC)$ where R and C are the external timing components.

TABLE 2
Major Applications for Exar's IC Oscillators

Major Application	XR-205	XR-2206	XR-2207	XR-2209	XR-8038
Sine Wave Generation	✓	✓			✓
Amplitude Modulation	✓	✓			
Frequency Modulation	✓	✓	✓	✓	✓
High-Frequency Operation (> 1 MHz)	✓				
FSK MODEMs		✓	✓		
Stable Oscillator (< 50 ppm/°C Drift)		✓	✓	✓	✓
Variable Duty Cycle	✓	✓	✓		✓
Output dc-level Control		✓			
Ultra-Low Frequency Operation (< 0.1 Hz)					✓
Linear Sweep Oscillator (> 1000:1)		✓	✓	✓	✓
Simultaneous Sine/Triangle Outputs					✓
Phase-Locked Loop Design	✓	✓	✓	✓	✓

Quality Assurance Standards

The quality assurance program at Exar Integrated Systems defines and establishes standards and controls on manufacturing, and audits product quality at critical points during manufacturing. The accompanying Manufacturing/QA process flows illustrate where quality assurance audits, by inspection or test, the manufacturing process. The insertion of these quality assurance points is designed to insure the highest quality standards are maintained on Exar product during its manufacture.

Realizing that these standard Manufacturing/QA process flows do not meet the needs of every customer's specific requirements, Exar quality assurance can negotiate and will screen product to meet any individual customer's specific requirement.

All products ending with the suffix M are fully screened to the requirements of MIL-STD-883, Method 5004, Condition C.

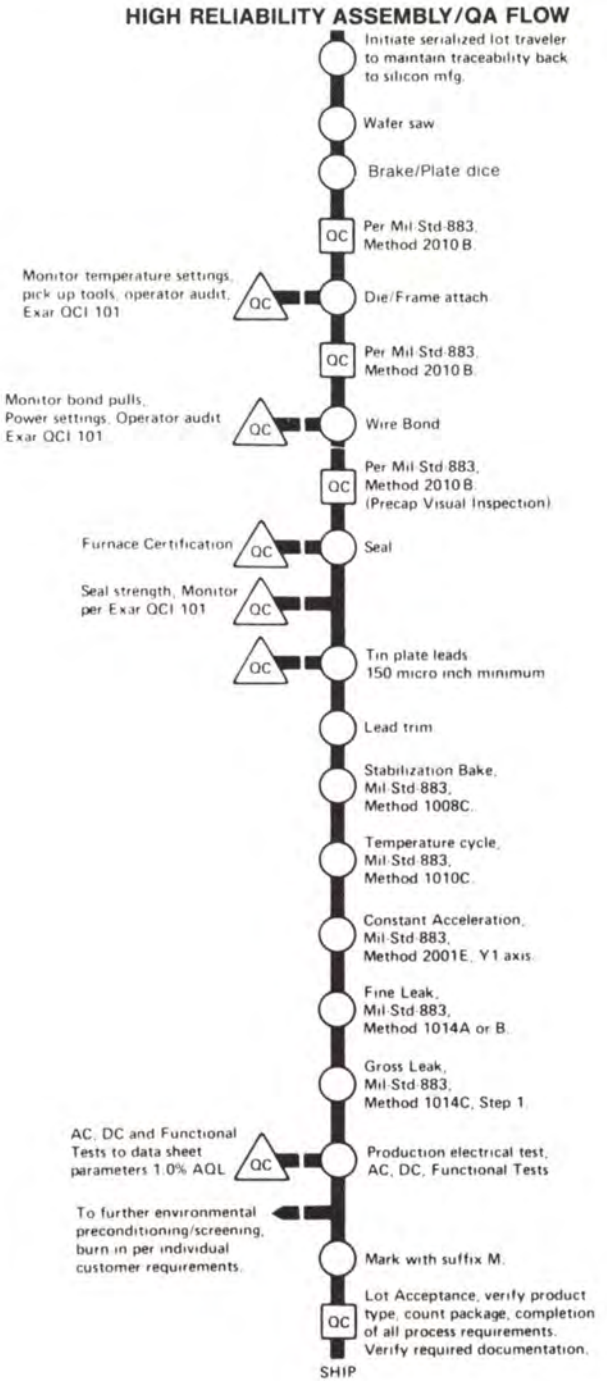
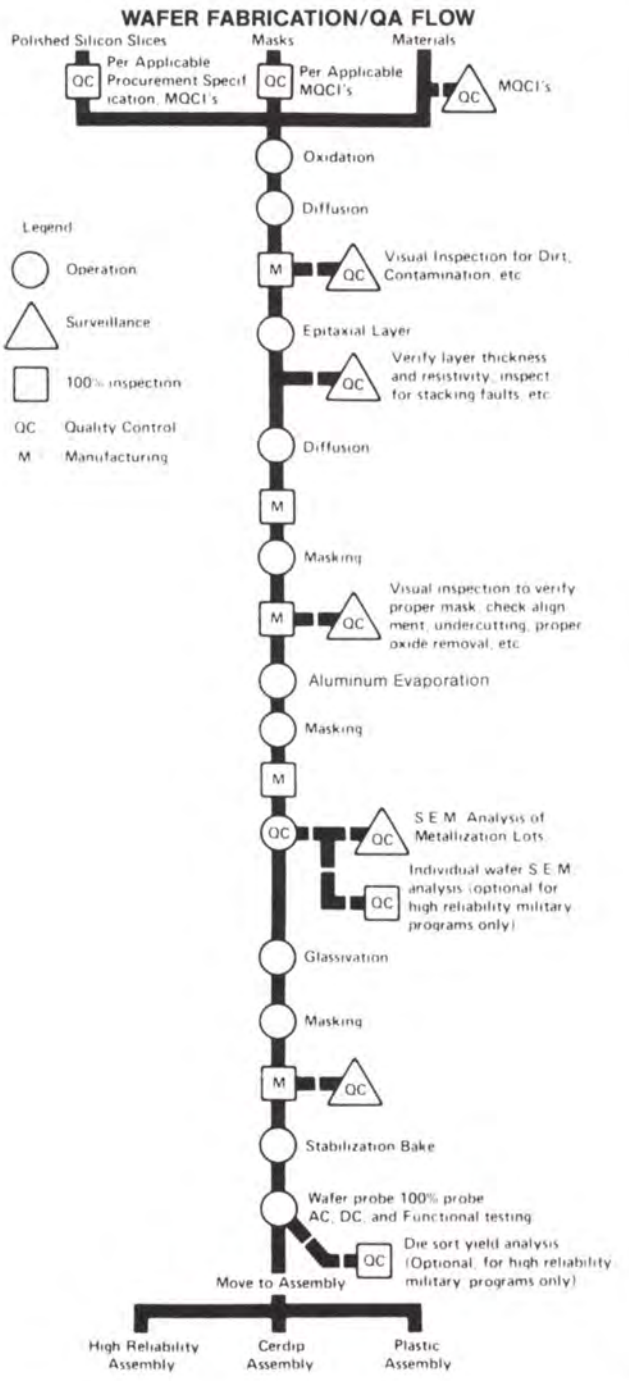

XR-205

Monolithic Waveform Generator

GENERAL DESCRIPTION

The XR-205 is a highly versatile, monolithic waveform generator designed for diverse applications in communication and telemetry equipment, as well as in systems design and testing. It is a self-contained, totally monolithic signal generator that provides sine, square, triangle, ramp and sawtooth output waveforms, which can be both amplitude and frequency modulated.

The functional block diagram of the monolithic waveform generator is shown below. The circuit has three separate sections: a voltage-controlled oscillator (VCO) which generates the basic periodic waveforms; a balance modulator which provides amplitude or phase modulation; a buffer amplifier section which provides a low impedance output with high current drive capability.

APPLICATIONS

Waveform Generation

Sinewave	Sawtooth
Triangle	Ramp
Square	Pulse

AM Generation Double Sideband Suppressed Carrier
Crystal-Controlled

FM Generation

Sweep Generation

Tone Burst Generation

Simultaneous AM/FM

Frequency-Shift Keyed (FSK) Signal Generation

Phase-Shift Keyed (PSK) Signal Generation

On-Off Keyed Oscillation

Clock Generation

ABSOLUTE MAXIMUM RATINGS

Power Supply	26 volts
Power Dissipation	750 mW
Derate above +25°C	6 mW/°C
Temperature Storage	-65°C to +150°C

AVAILABLE TYPES

Part Number	Package Type	Operating Temperature Range
XR-205	Ceramic	0°C to +75°C

EQUIVALENT SCHEMATIC DIAGRAM

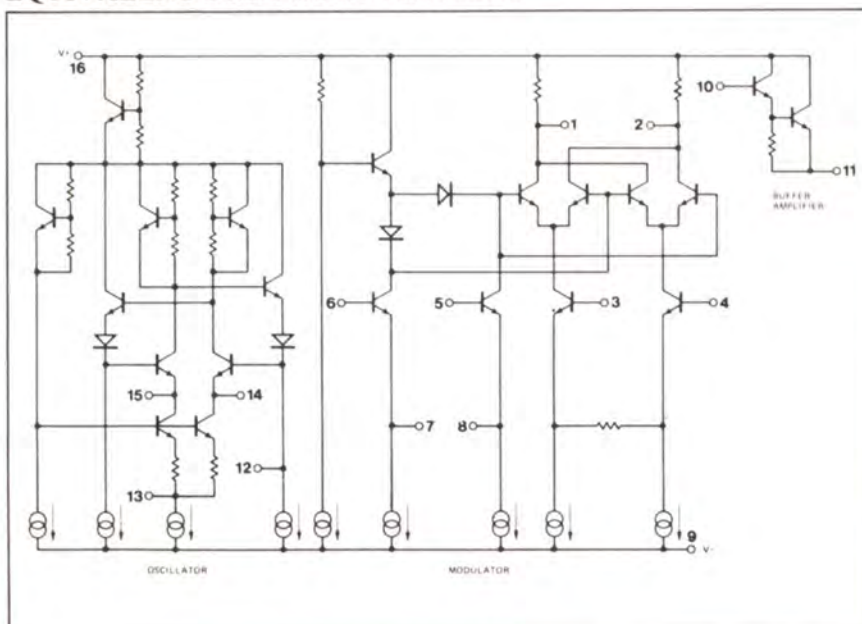

FUNCTIONAL BLOCK DIAGRAM

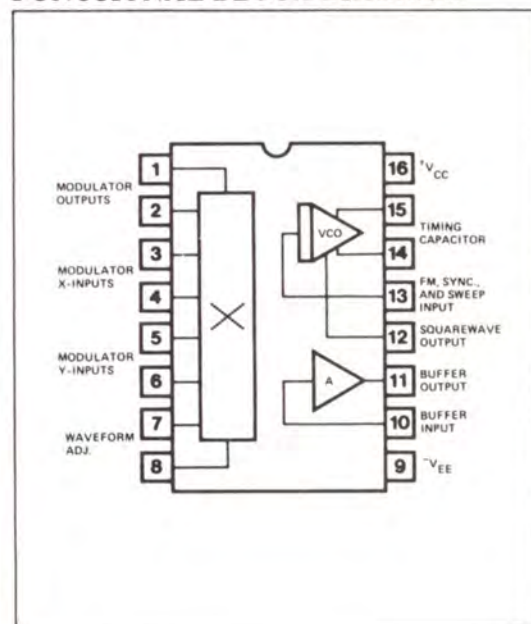

If You Didn't Get This From My Site,
Then It Was Stolen From...

ELECTRICAL CHARACTERISTICS

Test Conditions: Supply Voltage = 12V (single supply) $T_A = 25^\circ\text{C}$, $f = 10\text{ kHz}$, $R_L = 3\text{ k}\Omega$, unless otherwise specified.

CHARACTERISTICS	LIMITS			UNITS	CONDITIONS
	MIN.	TYP.	MAX.		
I – General Characteristics					
Supply Voltage: Single Supply	8		26	Vdc	See Figure 1
Split Supply	± 5		± 13	Vdc	See Figures 2 and 3
Supply Current	8	10	12	mA	w/o buffer amp
Frequency Stability: Power Supply		0.2	0.5	%/V	$ V_{CC} - V_{EE} > 10\text{V}$ Sweep input open circuit
Temperature		300	600	ppm/ $^\circ\text{C}$	
Frequency Sweep Range	7:1	10:1			See Figure 7
Output Swing: Single Ended	2	3		Vpp	Measured at pin 1 or 2 Measured across 1 and 2
Differential	4	6		Vpp	
Output Diff. Offset Voltage		0.1	0.4	Vdc	Measured across 1 and 2
Amplitude Control Range		60		dB	Controlled by R_Q (see Figure 1)
Buffer Amplifier Output Resistance		50		ohms	$R_L = 750\Omega$
Output Current Swing	± 6	± 10		mA	
II – Output Waveforms					
Sinusoidal: Upper Frequency Limit	2	4		MHz	Measured at Pin 11 S_1, S_3 closed, S_2 open closed S_2 open
Peak Output Swing	2	3		Vpp	
Distortion (THD)		2.5	4	%	
Triangle: Peak Swing	2	4		Vpp	Measured at Pin 11 S_1, S_2 open, S_3 closed $f = 10\text{ kHz}$
Non-Linearity		± 1		%	
Asymmetry		± 1		%	
Sawtooth: Peak Swing	2	3		Vpp	See Figure 1, S_2 closed; S_2 and S_3 closed
Non-Linearity		1.5		%	
Ramp: Peak-Swing	1	1.4		Vpp	See Figure 1, S_2 and S_3 open pin 10 shorted to pin 15
Non-Linearity		1		%	
Squarewave (Low Level): Output Swing	0.5	0.7	± 4	Vpp	See Figure 1, S_2 and S_3 open, pin 10 shorted to pin 12 10 pF connected from pin 11 to ground
Duty Cycle Asymmetry		± 1		%	
Rise Time		20		ns	
Fall Time		20		ns	
Squarewave (High Level): Peak Swing	2	3	± 4	Vpp	See Figure 3, S_2 open 10 pF connected from pin 11 to ground
Duty Cycle Asymmetry		± 1		%	
Rise Time		80		ns	
Fall Time		60		ns	
Pulse Output: Peak Swing	2	3		Vpp	See Figure 3, S_2 closed See Figure 3, S_2 closed
Rise Time		80		ns	
Fall Time		60		ns	
Duty Cycle Range				20-80	
III – Modulation Characteristics (sine, triangle and squarewave):					
Amplitude Modulation: Double Sideband					See Figure 2 for 30% modulation $f < 1\text{ MHz}$
Modulation Range		0-100		%	
Linearity		0.5		%	
Sideband Symmetry		1.0		%	
Suppressed Carrier Carrier Suppression		52		dB	
Frequency Modulation: Distortion		0.3		%	See Figure 2 (± 10 frequency deviation)

TEST CIRCUITS

DESCRIPTION OF CIRCUIT CONTROLS

(Refer to functional block diagram)

TIMING CAPACITOR (PINS 14 AND 15)

The oscillator frequency is inversely proportional to the value of the timing capacitor, C_o , connected between pins 14 and 15. With the sweep input open circuited, frequency f_o can be approximated as $f_o = 400/C_o$ where f_o is in Hz and C_o is in microfarads. (See Figure 4.)

MODULATOR Y-INPUTS (PINS 5 AND 6)

These inputs are normally connected to the oscillator outputs. For sinewave or trianglewave outputs, they are dc coupled to pins 14 and 15 (see Figure 1); for high-level squarewave or pulse output, ac coupling is used as shown in Figure 3.

MODULAR X-INPUTS (PINS 3 AND 4)

Modulator output (at pins 1 or 2) is proportional to a dc voltage applied across these inputs – (see Figure 5). These inputs can be used for amplitude modulation or, as an output amplitude control. The phase of the output voltage is reversed if the polarity of the dc bias across pins 3 and 4 is reversed; therefore these inputs can be used for phase-shift keyed (PSK) modulation.

MODULATOR OUTPUTS (PINS 1 AND 2)

All of the high level output waveforms are obtained at these terminals. The output waveforms appear differentially between pins 1 and 2. The terminals can, therefore, be used for either in-phase or out-of-phase outputs. Normally, a 15 K Ω load resistor should be connected between these terminals to prevent the output from saturating or clipping at large output voltage swings.

LOW LEVEL SQUAREWAVE OUTPUT (PIN 12)

The output at this pin is a symmetrical squarewave with 0.7V amplitude and 20 ns rise time. It can be used directly as an output waveform, or amplified to a 3 Vpp signal level using the modulator section of the XR-205 as an amplifier (see Figure 3).

SWEEP OR FM INPUT (PIN 13)

The oscillator frequency increases linearly with an increasing *negative* voltage, V_s , applied to this terminal. Normally a series resistor, R_s ($R_s \approx$ approx. 1 K Ω) is connected in series with this terminal to provide current limiting and linear voltage-to-frequency transfer characteristics. The frequency derivation (for any given modulation level) is inversely proportional to R_s . Typical sweep characteristics of the circuit are shown in Figure 7. For proper operation of the circuit with $R_s = 1$ K Ω , the sweep voltage, V_s , must be within range: $(V_{SO} - 6) < V_s < (V_{SO} + 1)$ where V_{SO} is the open circuit voltage at pin 13. The frequency of oscillation can also be synchronized to an external source by applying a sync pulse to this terminal. For $R_s = 1$ K Ω , a sync pulse of 0.1V to 1V amplitude is recommended.

WAVEFORM ADJUSTMENT (PINS 7 AND 8)

The shape of the output waveform at pins 1 and 2 is controlled by a potentiometer, R_j , connected between these terminals as shown in Figure 1. For sinewave outputs at pins 1 and 2, the value of R_j is adjusted to minimize the harmonic content of the output waveform. This adjustment is independent of frequency and *needs to be done only once*. The output can be converted to a symmetrical triangle waveform by increasing the effective resistance across these terminals. This can be done without changing the potentiometer setting, by opening the switch S_2 as shown in Figures 1–3.

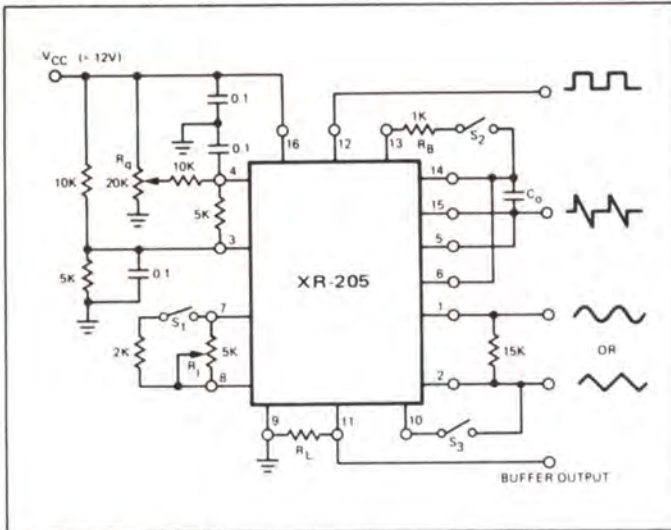

Figure 1. Test Circuit for Single-Supply Operation

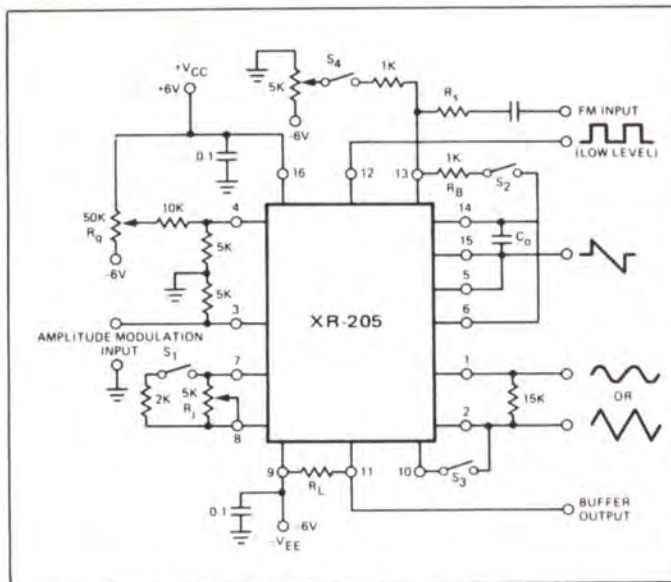

Figure 2. Test Circuit for Split-Supply Operation and AM/FM Modulation

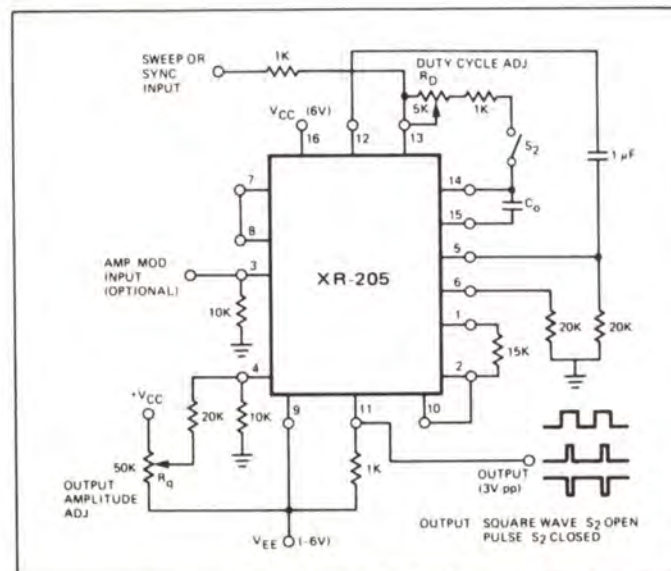

Figure 3. Test Circuit for High-Level Pulse and Squarewave Output

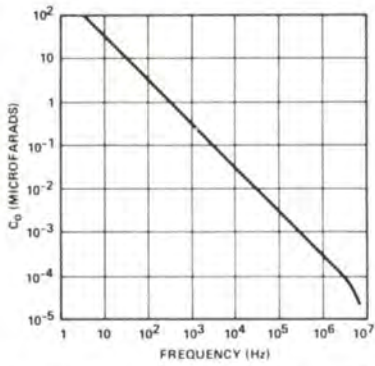

Figure 4. Frequency as a Function of C_0 Across Pins 14 and 15

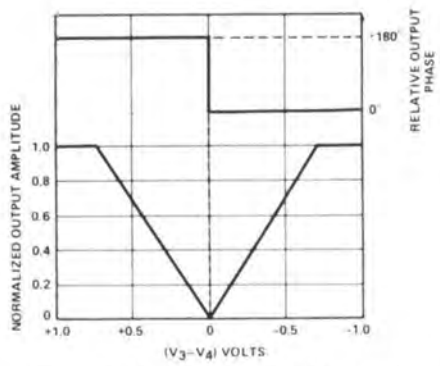

Figure 5. Modulator Section Phase and Amplitude Transfer Characteristics

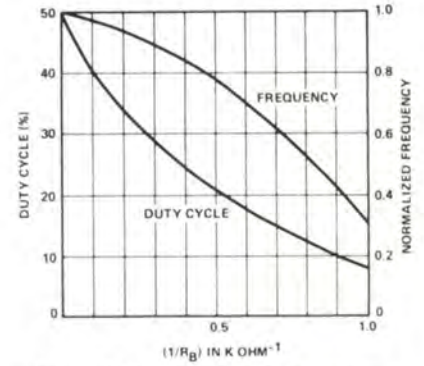

Figure 6. Duty-Cycle and Frequency Variation as a Function of Resistor R_B Connected Across Pins 13 and 14

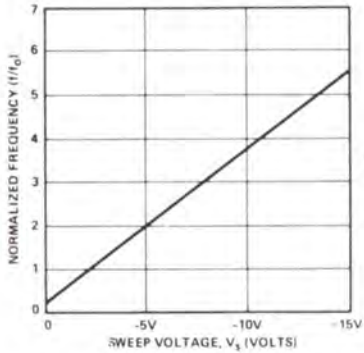

Figure 7. Normalized Frequency vs. Sweep Voltage

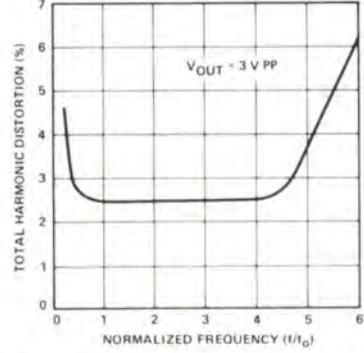
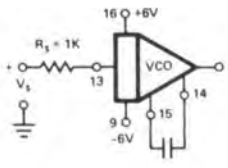

Figure 8. Sinusoidal Output Distortion as a Function of Frequency Sweep

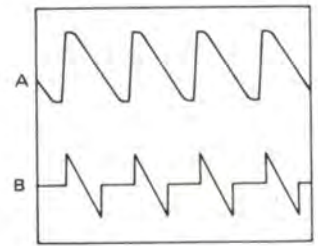

Figure 9. Sinusoidal Sawtooth and Linear Ramp Outputs

BUFFER INPUT AND OUTPUT (PINS 10 AND 11)

The buffer amplifier can be connected to any of the circuit outputs (pins 1, 2, 12, 14 or 15) to provide low output impedance and high current drive capability. For proper operation of the buffer amplifier, pin 11 must be connected to the most negative potential in the circuit, with an external load resistor R_L ($0.75 \text{ K}\Omega < R_L < 10 \text{ K}\Omega$). The maximum output current at this pin must not exceed 20 mA.

DUTY CYCLE ADJUSTMENT

The duty-cycle of the output waveforms can be adjusted by connecting a resistor R_B across pins 13 and 14, as shown in Figures 1-3. With switch S_2 open, the output waveform will be symmetrical. Duty cycle is reduced as R_B is decreased. (See Figure 6.)

ADDITIONAL GAIN CONTROL

For amplitude modulated output signals, the dc level across pins 3 and 4 is fixed by the modulation index required. In this case, the output amplitude can be controlled without effecting the modulation by connecting a potentiometer between pins 1 and 2.

ON-OFF KEYING

The oscillator can be keyed off by applying a positive voltage pulse to the sweep input terminal. With $R_S = 1 \text{ K}\Omega$, oscillations will stop if the applied potential at pin 13 is raised 3 volts above its open-circuit value.

OUTPUT WAVEFORMS

TRIANGLE OUTPUT

The circuit is connected as shown in Figures 1 or 2, with switches S_1 and S_2 open.

SINEWAVE OUTPUT

The circuit is connected as shown in Figures 1 or 2, with switch S_2 open and S_1 closed. The output waveform is adjusted for minimum harmonic distortion using trimmer resistor R_j connected across pins 7 and 8. Sinusoidal output is obtained from pins 1 or 2 (or pin 11 if the buffer amplifier is used). The amplitude of the output waveform is controlled by the differential dc voltage appearing between pins 3 and 4. This bias can be controlled by potentiometer R_q . For a differential bias between these terminals of ± 2 volts or greater, the output amplitude is maximum and equal to approximately 3 volts p-p.

SAWTOOTH OUTPUT

The circuit is connected as shown in Figures 1 or 2, with switch S_1 open and S_2 closed. Closing S_2 places resistor R_B across pins 13 and 14. This changes the duty cycle of the triangle output and converts it to a sawtooth waveform. The polarity of the sawtooth can be changed by reversing the polarity of the dc bias across pins 3 and 4. If S_1 is closed, the linear sawtooth waveform is converted to the sinusoidal sawtooth waveform of Figure 9A.

RAMP OUTPUT (FIGURE 9B)

For ramp outputs, switch S_3 of Figure 1 or 2 is opened, and pin 10 is shorted to pin 14. This results in a 1.4 volt p-p ramp output at pin 11. The duty cycle of this ramp can be controlled by connecting R_B across pins (13-14) or (13-15).

SQUAREWAVE AND PULSE OUTPUTS

For squarewave outputs, the circuit is connected as shown in Figure 3, with S_2 open. The output can be converted to a pulse by closing S_2 . The duty cycle of the pulse output is controlled by potentiometer R_D . The amplitude and polarity of either the pulse or squarewave output can be controlled by potentiometer R_q .

XR-2206

Monolithic Function Generator

The XR-2206 is a monolithic function generator integrated circuit capable of producing high quality sine, square, triangle, ramp and pulse waveforms of high stability and accuracy. The output waveforms can be both amplitude and frequency modulated by an external voltage. Frequency of operation can be selected externally over a range of 0.01 Hz to more than 1 MHz.

The XR-2206 is ideally suited for communications, instrumentation, and function generator applications requiring sinusoidal tone, AM, FM or FSK generation. It has a typical drift specification of 20 ppm/°C. The oscillator frequency can be linearly swept over a 2000:1 frequency range with an external control voltage with very little affect on distortion.

As shown in Figure 1, the monolithic circuit is comprised of four functional blocks: a voltage-controlled oscillator (VCO); an analog multiplier and sine-shaper; a unity gain buffer amplifier; and a set of current switches. The internal current switches transfer the oscillator current to any one of the two external timing resistors to produce two discrete frequencies selected by the logic level at the FSK input terminal (pin 9).

FEATURES

- Low Sinewave Distortion (THD .5%) – insensitive to signal sweep
- Excellent Stability (20 ppm/°C, typ)
- Wide Sweep Range (2000:1, typ)
- Low Supply Sensitivity (0.01%/V, typ)
- Linear Amplitude Modulation
- Adjustable Duty-Cycle (1% to 99%)
- TTL Compatible FSK Controls
- Wide Supply Range (10V to 26V)

APPLICATIONS

- Waveform Generation
 - Sine, Square, Triangle, Ramp
- Sweep Generation
- AM/FM Generation
- FSK and PSK Generation
- Voltage-to-Frequency Conversion
- Tone Generation
- Phase-Locked Loops

ABSOLUTE MAXIMUM RATINGS

Power Supply	26V
Power Dissipation (package limitation)	
Ceramic package	750 mW
Derate above +25°C	6.0 mW/°C
Plastic package	625 mW
Derate above +25°C	5 mW/°C
Storage Temperature Range	-65°C to +150°C

AVAILABLE TYPES

Part Number	Package Types	Operating Temperature Range
XR-2206M	Ceramic	-55°C to +125°C
XR-2206N	Ceramic	0°C to +75°C
XR-2206P	Plastic	0°C to +75°C
XR-2206CN	Ceramic	0°C to +75°C
XR-2206CP	Plastic	0°C to +75°C

EQUIVALENT SCHEMATIC DIAGRAM

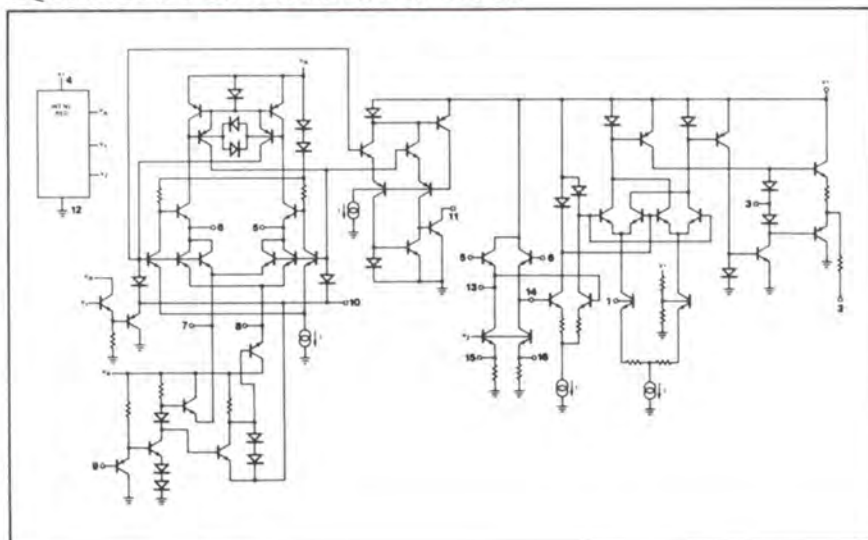

FUNCTIONAL BLOCK DIAGRAM

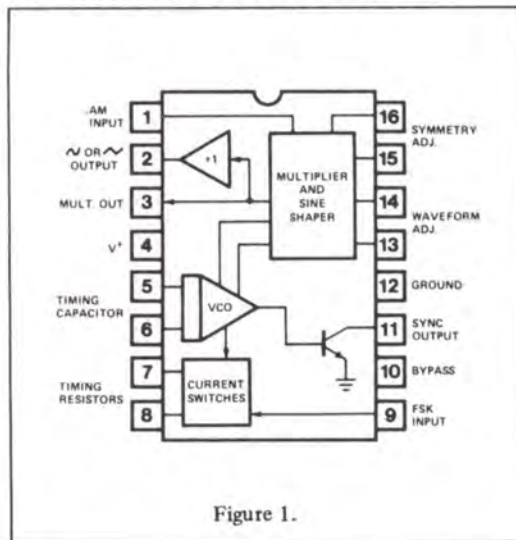

ELECTRICAL CHARACTERISTICS

Test Conditions: Test Circuit of Fig. 2, $V^+ = 12V$, $T_A = 25^\circ C$, $C = 0.01 \mu F$, $R_1 = 100 K\Omega$, $R_2 = 10 K\Omega$, $R_3 = 25 K\Omega$ unless otherwise specified. S_1 open for triangle, closed for sinewave.

CHARACTERISTICS	XR-2206/XR-2206M			XR-2206C			UNITS	CONDITIONS
	MIN.	TYP.	MAX.	MIN.	TYP.	MAX.		
Supply Voltage	10		26	10		26	V	$R_1 \geq 10 K\Omega$
Single Supply	± 5		± 13	± 5		± 13	V	
Split Supply		12	17		14	20	mA	
Supply Current								
Oscillator Section								
Max. Operating Frequency	0.5	1		0.5	1		MHz	$C = 1000 \mu F$, $R_1 = 1 K\Omega$
Lowest Practical Frequency		0.01			0.01		Hz	$C = 50 \mu F$, $R_1 = 2 M\Omega$
Frequency Accuracy		± 1	± 4		± 2		% of f_0	$f_0 = 1/R_1 C$
Temperature Stability		± 10	± 50		± 20		ppm/ $^\circ C$	$0^\circ C \leq T_A \leq 75^\circ C$, $R_1 = R_2 = 20 K\Omega$
Supply Sensitivity		0.01	0.1		0.01		%/V	$V_{LOW} = 10V$, $V_{HIGH} = 20V$, $R_1 = R_2 = 20 K\Omega$
Sweep Range	1000:1	2000:1			2000:1		$f_H = f_L$	$f_H @ R_1 = 1 K\Omega$ $f_L @ R_1 = 2 M\Omega$
Sweep Linearity								
10:1 Sweep		2			2		%	$f_L = 1 kHz$, $f_H = 10 kHz$
1000:1 Sweep		8			8		%	$f_L = 100 Hz$, $f_H = 100 kHz$
FM Distortion		0.1			0.1		%	$\pm 10\%$ Deviation
Recommended Timing Components								
Timing Capacitor: C	0.001		100	0.001		100	μF	See Figure 5
Timing Resistors: R_1 & R_2	1		2000	1		2000	$K\Omega$	
Triangle/Sinewave Output								
Triangle Amplitude		160			160		mV/ $K\Omega$	See Note 1, Fig. 3
Sinewave Amplitude	40	60	80		60		mV/ $K\Omega$	Fig. 2 S_1 Open
Max. Output Swing		6			6		V _{pp}	Fig. 2 S_1 Closed
Output Impedance		600			600		Ω	
Triangle Linearity		1			1		%	
Amplitude Stability		0.5			0.5		dB	For 1000:1 Sweep
Sinewave Amplitude Stability		-4800			-4800		ppm/ $^\circ C$	See Note 2
Sinewave Distortion								
Without Adjustment		2.5			2.5		%	$R_1 = 30 K\Omega$
With Adjustment		0.4	1.0		0.5	1.5	%	See Figure 11
Amplitude Modulation								
Input Impedance	50	100		50	100		$K\Omega$	
Modulation Range		100			100		%	
Carrier Suppression		55			55		dB	
Linearity		2			2		%	For 95% modulation
Square Wave Output								Measured at Pin 11
Amplitude		12			12		V _{pp}	
Rise Time		250			250		nsec	$C_L = 10 pF$
Fall Time		50			50		nsec	$C_L = 10 pF$
Saturation Voltage		0.2	0.4		0.2	0.6	V	$I_L = 2 mA$
Leakage Current		0.1	20		0.1	100	μA	$V_{I1} = 26V$
FSK Keying Level (Pin 9)	0.8	1.4	2.4	0.8	1.4	2.4	V	See Section on Circuit Controls
Reference Bypass Voltage	2.9	3.1	3.3	2.5	3	3.5	V	Measured at Pin 10.

Note 1: Output Amplitude is directly proportional to the resistance R_3 on Pin 3. See Figure 3.

Note 2: For maximum amplitude stability R_3 should be a positive temperature coefficient resistor.

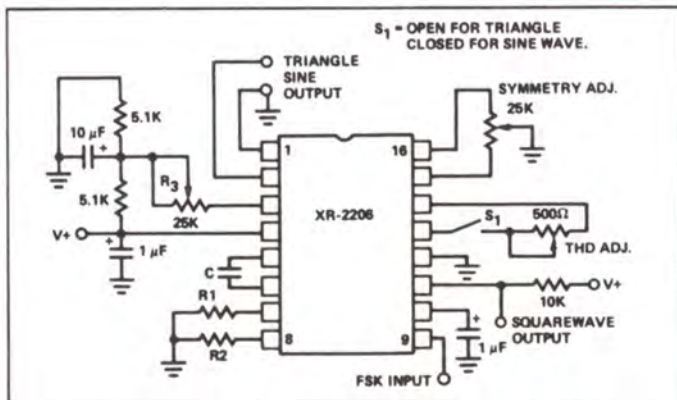

Figure 2. Basic Test Circuit

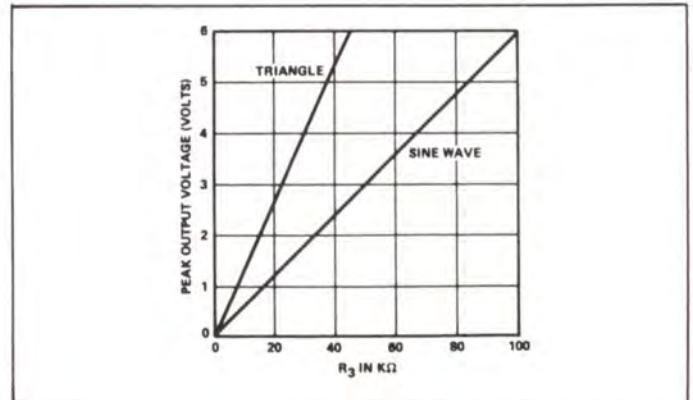

Figure 3. Output Amplitude as a Function of Resistor R_3 at Pin 3.

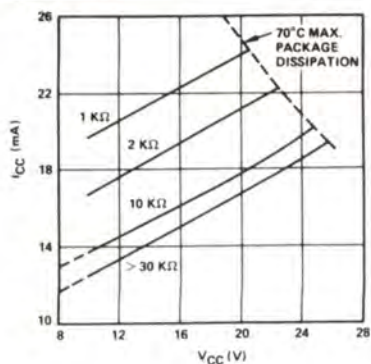

Figure 4. Supply Current vs Supply Voltage, Timing R

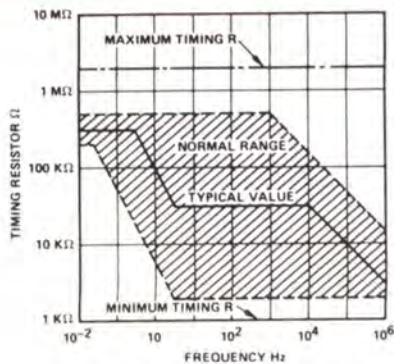

Figure 5. R vs Oscillation Frequency

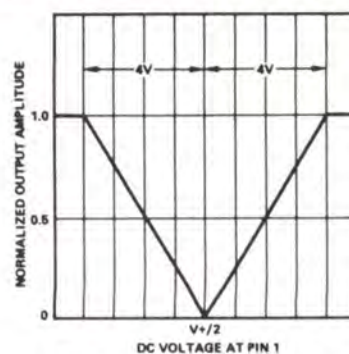

Figure 6. Normalized Output Amplitude vs DC Bias at AM Input (Pin 1).

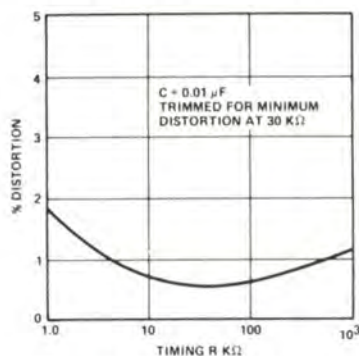

Figure 7. Trimmed Distortion vs Timing Resistor

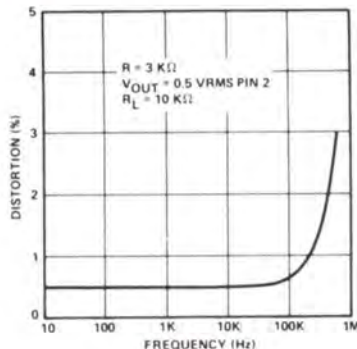

Figure 8. Signwave Distortion vs Operating Frequency With Timing Capacitors Varied

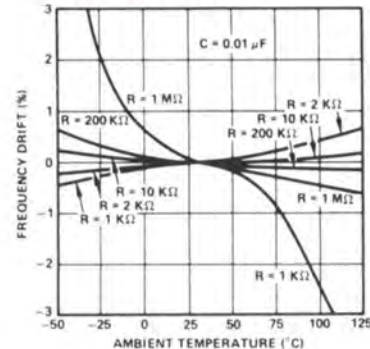

Figure 9. Frequency Drift vs Temperature

DESCRIPTION OF CIRCUIT CONTROLS

FREQUENCY OF OPERATION:

The frequency of oscillation, f_o , is determined by the external timing capacitor C across pins 5 and 6, and by the timing resistor R connected to either pin 7 or pin 8. The frequency is given as

$$f_o = \frac{1}{RC} \text{ Hz}$$

and can be adjusted by varying either R or C. The recommended values of R for a given frequency range are shown in Figure 5. Temperature-stability is optimum for $4 \text{ K}\Omega < R < 200 \text{ K}\Omega$. Recommended values of C are from 1000 pF to 100 μF .

FREQUENCY SWEEP AND MODULATION

Frequency of oscillation is proportional to the total timing current I_T drawn from pin 7 or 8

$$f = \frac{320I_T \text{ (mA)}}{C \text{ (}\mu\text{F)}} \text{ Hz}$$

Timing terminals (pins 7 or 8) are low impedance points and are internally biased at +3V, with respect to pin 12. Frequency varies linearly with I_T over a wide range of current values, from 1 μA to 3 mA. The frequency can be controlled by applying a control voltage, V_C , to the activated timing pin as shown in Figure 10. The frequency of oscillation is related to V_C as:

$$f = \frac{1}{RC} \left[1 + \frac{R}{RC} \left(1 - \frac{V_C}{3} \right) \right] \text{ Hz}$$

where V_C is in volts. The voltage-to-frequency conversion gain, K, is given as:

$$K = \partial f / \partial V_C = - \frac{0.32}{R_C C} \text{ Hz/V}$$

NOTE: For safe operation of the circuit I_T should be limited to $\leq 3 \text{ mA}$.

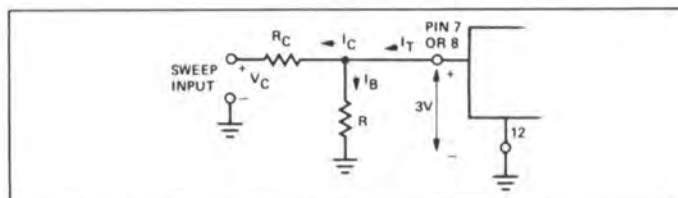

Figure 10. Circuit Connection for Frequency Sweep

OUTPUT CHARACTERISTICS:

Output Amplitude: Maximum output amplitude is directly proportional to external resistor R_3 connected to Pin 3 (See Fig. 3). For sinewave output, amplitude is approximately 60 mV peak per $\text{K}\Omega$ of R_3 ; for triangle, the peak amplitude is approximately 160 mV peak per $\text{K}\Omega$ of R_3 . Thus, for example, $R_3 = 50 \text{ K}\Omega$ would produce approximately $\pm 3\text{V}$ sinusoidal output amplitude.

Amplitude Modulation: Output amplitude can be modulated by applying a dc bias and a modulating signal to Pin 1. The internal impedance at Pin 1 is approximately 100 $\text{K}\Omega$. Output amplitude varies linearly with the applied voltage at Pin 1, for values of dc bias at this pin, within ± 4 volts of $V^+/2$ as shown in Fig. 6. As this bias level approaches $V^+/2$, the phase of the output signal is reversed; and the amplitude goes through zero. This property is suitable for phase-shift keying and suppressed-carrier AM generation. Total dynamic range of amplitude modulation is approximately 55 dB.

Note: AM control must be used in conjunction with a well-regulated supply since the output amplitude now becomes a function of V^+ .

FREQUENCY-SHIFT KEYING

The XR-2206 can be operated with two separate timing resistors, R_1 and R_2 , connected to the timing pins 7 and 8, respectively, as shown in Figure 13. Depending on the polarity of the logic signal at pin 9, either one or the other of these timing

resistors is activated. If pin 9 is open-circuited or connected to a bias voltage $\geq 2V$, only R_1 is active. Similarly, if the voltage level at pin 9 is $\leq 1V$, only R_2 is activated. Thus, the output frequency can be keyed between two levels, f_1 and f_2 as:

$$f_1 = 1/R_1C \text{ and } f_2 = 1/R_2C$$

For split-supply operation, the keying voltage at pin 9 is referenced to V^- .

OUTPUT DC LEVEL CONTROL

The dc level at the output (pin 2) is approximately the same as the dc bias at pin 3. In Figures 11, 12 and 13, pin 3 is biased mid-way between V^+ and ground, to give an output dc level of $\approx V^+/2$.

APPLICATIONS INFORMATION

SINEWAVE GENERATION

A) Without External Adjustment

Figure 11 shows the circuit connection for generating a sinusoidal output from the XR-2206. The potentiometer R_1 at pin 7 provides the desired frequency tuning. The maximum output swing is greater than $V^+/2$ and the

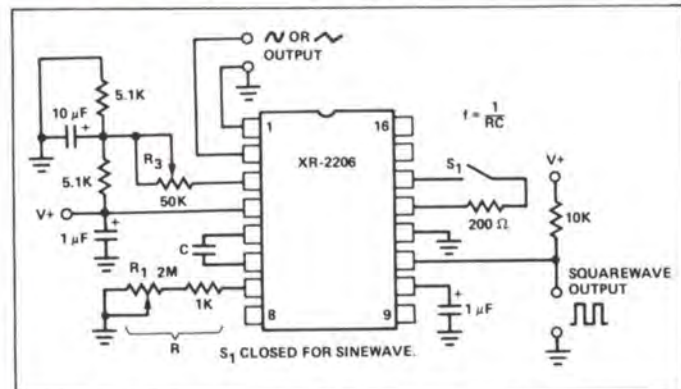

Figure 11. Circuit for Sinewave Generation Without External Adjustment. (See Fig. 3 for choice of R_3)

typical distortion (THD) is $< 2.5\%$. If lower sinewave distortion is desired, additional adjustments can be provided as described in the following section.

The circuit of Figure 11 can be converted to split supply operation simply by replacing all ground connections with V^- . For split supply operation, R_3 can be directly connected to ground.

B) With External Adjustment

The harmonic content of sinusoidal output can be reduced to $\approx 0.5\%$ by additional adjustments as shown in Figure 12. The potentiometer R_A adjusts the sine-shaping resistor;

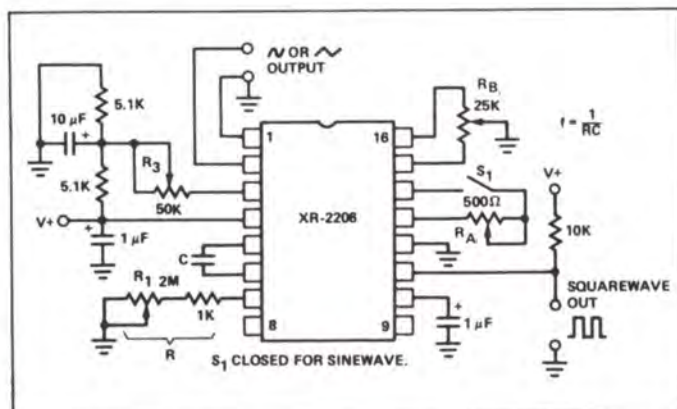

Figure 12. Circuit for Sinewave Generation With Minimum Harmonic Distortion. (R_3 Determines output Swing - See Fig. 3)

If You Didn't Get This From My Site,
Then It Was Stolen From...

and R_B provides the fine-adjustment for the waveform symmetry. The adjustment procedure is as follows:

1. Set R_B at mid-point and adjust R_A for minimum distortion.
2. With R_A set as above, adjust R_B to further reduce distortion.

TRIANGLE WAVE GENERATION

The circuits of Figures 11 and 12 can be converted to triangle wave generation by simply open circuiting pins 13 and 14 (i.e., S_1 open). Amplitude of the triangle is approximately twice the sinewave output.

FSK GENERATION

Figure 13 shows the circuit connection for sinusoidal FSK signal generation. Mark and space frequencies can be independently adjusted by the choice of timing resistors R_1 and R_2 ; and the output is phase-continuous during transitions. The keying signal is applied to pin 9. The circuit can be converted to split-supply operation by simply replacing ground with V^- .

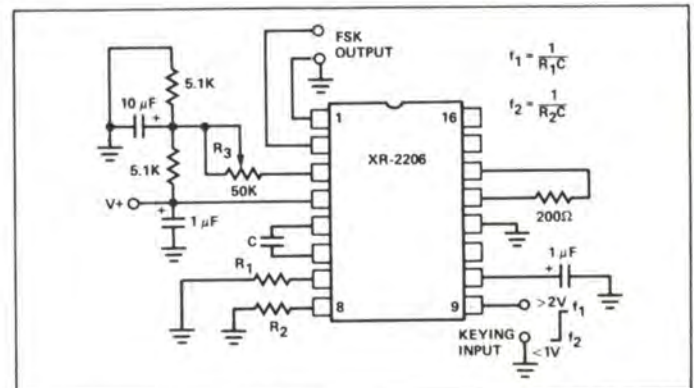

Figure 13. Sinusoidal FSK Generator

PULSE AND RAMP GENERATION

Figure 14 shows the circuit for pulse and ramp waveform generation. In this mode of operation, the FSK keying terminal (pin 9) is shorted to the square-wave output (pin 11); and the circuit automatically frequency-shift keys itself between two separate frequencies during the positive and negative going output waveforms. The pulse-width and the duty cycle can be adjusted from 1% to 99% by the choice of R_1 and R_2 . The values of R_1 and R_2 should be in the range of 1 K Ω to 2 M Ω .

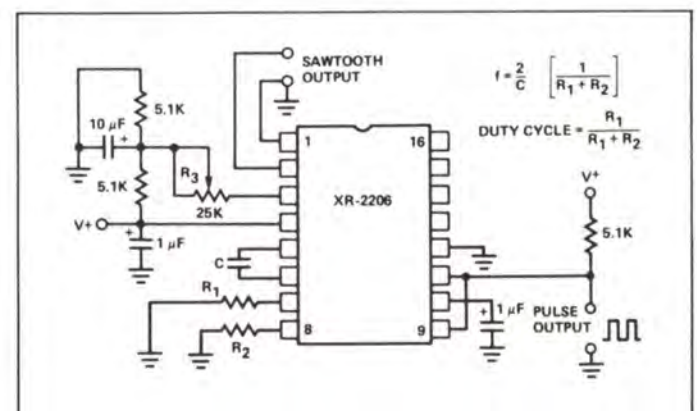

Figure 14. Circuit for Pulse and Ramp Generation

XR-2207

Voltage - Controlled Oscillator

GENERAL DESCRIPTION

The XR-2207 is a monolithic voltage-controlled oscillator (VCO) integrated circuit featuring excellent frequency stability and a wide tuning range. The circuit provides simultaneous triangle and squarewave outputs over a frequency range of 0.01 Hz to 1 MHz. It is ideally suited for FM, FSK, and sweep or tone generation, as well as for phase-locked loop applications.

The circuit is comprised of four functional blocks: a variable-frequency oscillator which generates the basic periodic waveforms; four current switches actuated by binary keying inputs; and buffer amplifiers for both the triangle and squarewave outputs. The internal current switches transfer the oscillator current to any of four external timing resistors to produce four discrete frequencies which are selected according to the binary logic levels at the keying terminals (pins 8 and 9).

The XR-2207 has a typical drift specification of 20 ppm/°C. The oscillator frequency can be linearly swept over a 1000:1 range with an external control voltage; and the duty cycle of both the triangle and the squarewave outputs can be varied from 0.1% to 99.9% to generate stable pulse and sawtooth waveforms.

FEATURES

- Excellent Temperature Stability (20 ppm/°C)
- Linear Frequency Sweep
- Adjustable Duty Cycle (0.1% to 99.9%)
- Two or Four Level FSK Capability
- Wide Sweep Range (1000:1 Min)
- Logic Compatible Input and Output Levels
- Wide Supply Voltage Range ($\pm 4V$ to $\pm 13V$)
- Low Supply Sensitivity (0.15%/V)
- Wide Frequency Range (0.01 Hz to 1 MHz)
- Simultaneous Triangle and Squarewave Outputs

APPLICATIONS

- FSK Generation
- Voltage and Current-to-Frequency Conversion
- Stable Phase-Locked Loop
- Waveform Generation
 - Triangle, Sawtooth, Pulse, Squarewave
- FM and Sweep Generation

ABSOLUTE MAXIMUM RATINGS

Power Supply	26V
Power Dissipation (package limitation)	
Ceramic package	750 mW
Derate above +25°C	6.0 mW/°C
Plastic package	625 mW
Derate above +25°C	5 mW/°C
Storage Temperature Range	-65°C to +150°C

AVAILABLE TYPES

Part Number	Package	Operating Temperature
XR2207M	Ceramic	-55°C to +125°C
XR2207N	Ceramic	0°C to +75°C
XR2207P	Plastic	0°C to +75°C
XR2207CN	Ceramic	0°C to +75°C
XR2207CP	Plastic	0°C to +75°C

EQUIVALENT SCHEMATIC DIAGRAM

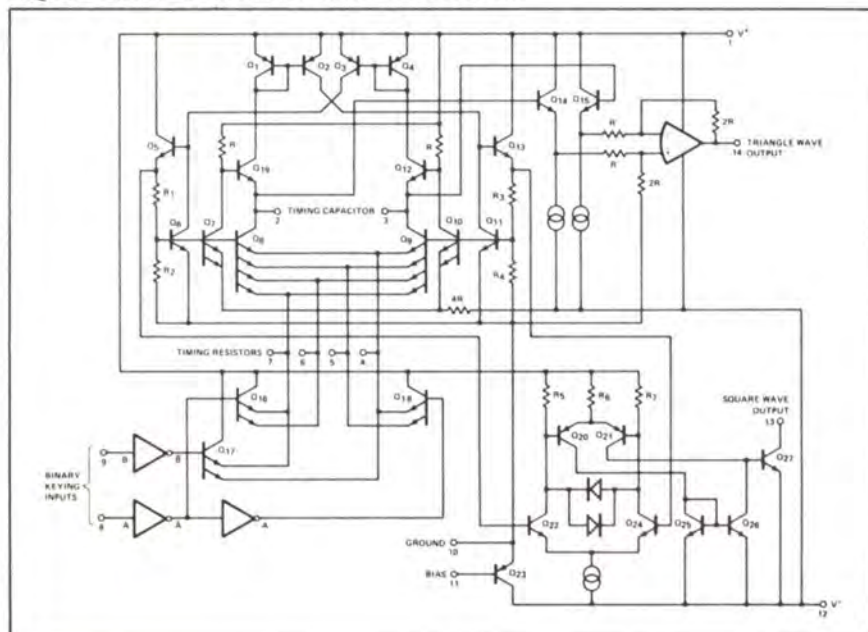

FUNCTIONAL BLOCK DIAGRAM

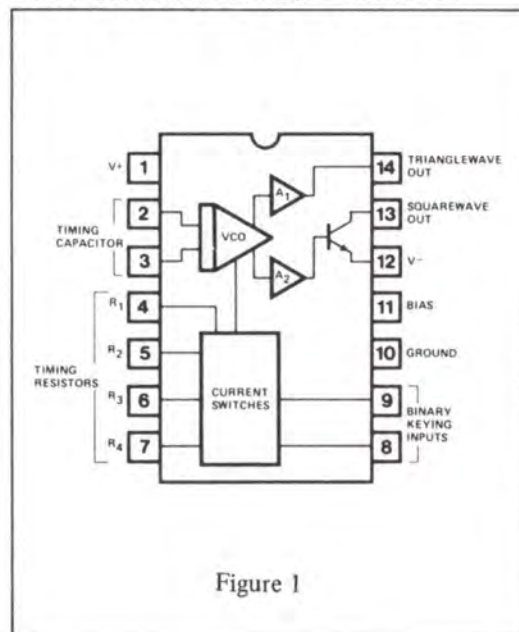

Figure 1

ELECTRICAL CHARACTERISTICS

Test Conditions: Test Circuit of Figure 1, $V^+ = V^- = 6V$, $T_A = +25^\circ C$, $C = 5000 \text{ pF}$, $R_1 = R_2 = R_3 = R_4 = 20 \text{ K}\Omega$, $R_L = 4.7 \text{ K}\Omega$, Binary Inputs grounded, S_1 and S_2 closed unless otherwise specified.

PARAMETERS	XR-2207/XR-2207M			XR-2207C			UNITS	CONDITIONS
	MIN.	TYP.	MAX.	MIN.	TYP.	MAX.		
GENERAL CHARACTERISTICS								
Supply Voltage								
Single Supply	8		26	8		26	V	See Figure 2
Split Supplies	± 4		± 13	± 4		± 13	V	See Figure 3
Supply Current								
Single Supply		5	7		5	8	mA	Measured at pin 1, S_1 and S_2 open, see Figure 2
Split Supplies								
Positive		5	7		5	8	mA	Measured at pin 1, S_1, S_2 open
Negative		4	6		4	7	mA	Measured at pin 12, S_1, S_2 open
OSCILLATOR SECTION – FREQUENCY CHARACTERISTICS								
Upper Frequency Limit	0.5	1.0		0.5	1.0		MHz	$C = 500 \text{ pF}$, $R_3 = 2 \text{ K}\Omega$
Lowest Practical Frequency		0.01			0.01		Hz	$C = 50 \text{ }\mu\text{F}$, $R_3 = 2 \text{ M}\Omega$
Frequency Accuracy		± 1	± 3		± 1	± 5	% of f_O	
Frequency Matching		0.5			0.5		% of f_O	
Frequency Stability								
Temperature		20	50		30		ppm/ $^\circ C$	$0^\circ < T_A < 75^\circ C$
Power Supply		0.15			0.15		%/V	
Sweep Range	1000:1	3000:1			1000:1		f_H/f_L	$R_3 = 1.5 \text{ K}\Omega$ for f_H $R_3 = 2 \text{ M}\Omega$ for f_L
Sweep Linearity								
10:1 Sweep		1	2		1.5		%	$C = 5000 \text{ pF}$ $f_H = 10 \text{ kHz}$, $f_L = 1 \text{ kHz}$
1000:1 Sweep		5			5		%	$f_H = 100 \text{ kHz}$, $f_L = 100 \text{ Hz}$
FM Distortion		0.1			0.1		%	$\pm 10\%$ FM Deviation
Recommended Range of Timing Resistors	1.5		2000	1.5		2000	$\text{K}\Omega$	See Characteristic Curves
Impedance at Timing Pins		75			75		Ω	Measured at pins 4, 5, 6, or 7
DC Level at Timing Terminals		10			10		mV	
BINARY KEYING INPUTS								
Switching Threshold	1.4	2.2	2.8	1.4	2.2	2.8	V	Measured at pins 8 and 9, Referenced to pin 10
Input Impedance		5			5		$\text{K}\Omega$	
OUTPUT CHARACTERISTICS								
Triangle Output								
Amplitude	4	6		4	6		V_{pp}	Measured at pin 13
Impedance		10			10		Ω	
DC Level		+100			+100		mV	Referenced to pin 10
Linearity		0.1			0.1		%	From 10% to 90% of swing
Square Wave Output								
Amplitude	11	12		11	12		V_{pp}	Measured at pin 13, S_2 closed
Saturation Voltage		0.2	0.4		0.2	0.4	V	Referenced to pin 12
Rise Time		200			200		nsec	$C_L \leq 10 \text{ pF}$
Fall Time		20			20		nsec	$C_L \leq 10 \text{ pF}$

PRECAUTIONS

The following precautions should be observed when operating the XR-2207 family of integrated circuits:

1. Pulling excessive current from the timing terminals will adversely effect the temperature stability of the circuit. To minimize this disturbance, it is recommended that the *total current* drawn from pins 4, 5, 6, and 7 be limited to ≤ 6 mA. In addition, permanent damage to the device may occur if the total timing current exceeds 10 mA.
2. Terminals 2, 3, 4, 5, 6, and 7 have very low internal impedance and should, therefore, be protected from accidental shorting to ground or the supply voltages.
3. The keying logic pulse amplitude should not exceed the supply voltage.

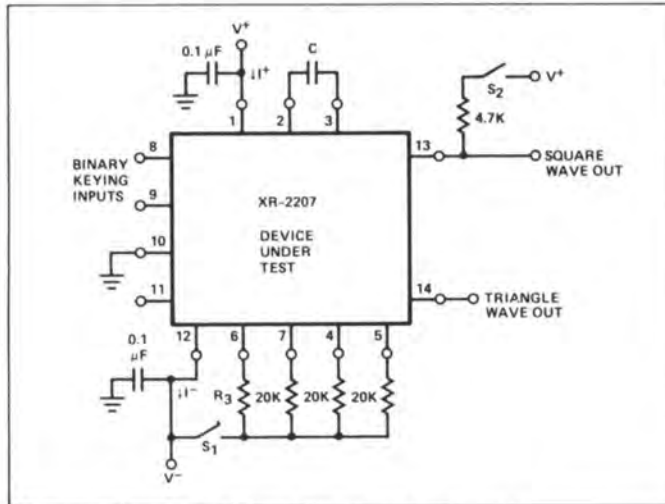

Figure 2. Test Circuit For Split Supply Operation

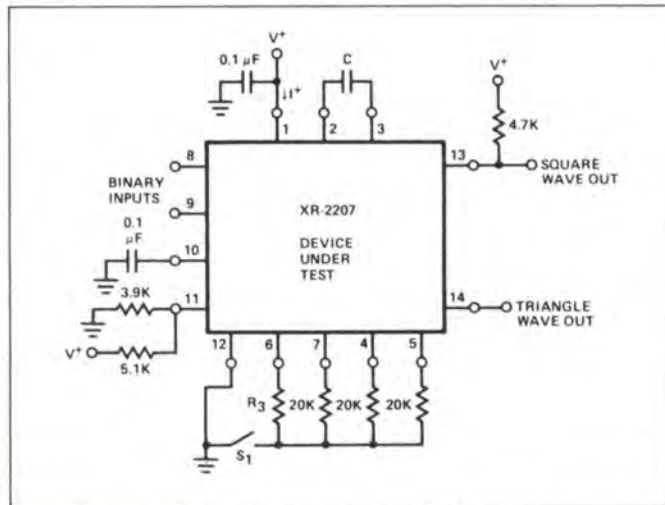

Figure 3. Test Circuit For Single Supply Operation

DEFINITION OF TERMS

FREQUENCY ACCURACY

The difference between the actual operating frequency and the theoretical frequency determined from the design equations in Figure 11, expressed as a percent of the calculated value.

FREQUENCY MATCHING

The change in operating frequency as different timing terminals are activated for fixed timing resistor and timing capacitor values, expressed as a percent of the original operating frequency.

BINARY INPUT SWITCHING THRESHOLD

The logic level at pins 8 and 9 cause the binary current switches to be activated. The voltage level is referenced to pin 10.

FREQUENCY SWEEP RANGE

The ratio of the highest and lowest operating frequencies (f_H/f_L) obtainable with a given value of timing capacitor.

SWEEP LINEARITY

The maximum deviation of the sweep characteristics from a best-fit straight line extending over the frequency range.

TRIANGLE NONLINEARITY

The maximum deviation from a best-fit straight line extending along the rising and falling edges of the waveform, measured between 10% and 90% of each excursion.

PRINCIPLE OF OPERATION

The XR-2207 oscillator is a modified emitter-couple multi-vibrator type. As shown in the block diagram of Figure 1, the oscillator also contains four current switches which activate the timing terminals, pins 4, 5, 6, and 7. The oscillator frequency is inversely proportional to the value of timing capacitance, C, between pins 2 and 3; and directly proportional to the total current, I_T , pulled out of the activated timing terminals.

Figure 12 provides greater detail of the oscillator control mechanism. Timing pins 4, 5, 6, and 7 correspond to the emitters of switching transistors T₁, T₂, T₃, and T₄ respectively, which are internal to the integrated circuit. The current switches (and corresponding timing terminals) are activated by external logic signals applied to the keying terminals, pins 8 and 9. The logic table for keying is given in Figure 11.

As an example, logic inputs of 0, 0 at pins 8 and 9 (i.e., both inputs "low") will result in turning on transistor pairs T₃; and only the timing terminal 6 will be activated. Under this condition, the total timing current, I_T , is equal to current I₃ pulled from pin 6. This current is determined by external resistor R₃, resulting in a frequency $f_0 = f_1 = 1/R_3C$ Hz.

It is important to observe that timing pins 4, 5, 6, and 7 are low impedance points in the circuit. Care must be taken, to avoid shorting these pins to the supply voltages or to ground.

OPERATING INSTRUCTIONS

SPLIT SUPPLY OPERATION

Figure 13 is the recommended circuit connections for split supply operation. With the generalized connections of Figure 13a, the frequency of operation is determined by timing capacitor, C, and the activated timing resistors (R₁ through R₄). The timing resistors are activated by the logic signals at the binary keying inputs (pins 8 and 9), as shown in the logic table in Figure 11. If a fixed frequency of oscillation is required, the circuit connections can be simplified as shown in Figure 13b. In this connection, the input logic is set at (0,0) and the operating frequency is equal to $(1/R_3C)$ Hz.

The squarewave output is obtained at pin 13 and has a peak-to-peak voltage swing equal to the supply voltages. This output is an "open-collector" type and requires an external pull-up load resistor (nominally 5 K Ω) to the positive supply. The triangle waveform obtained at pin 14 is centered about ground and has a peak amplitude of $V/2$.

TYPICAL CHARACTERISTICS

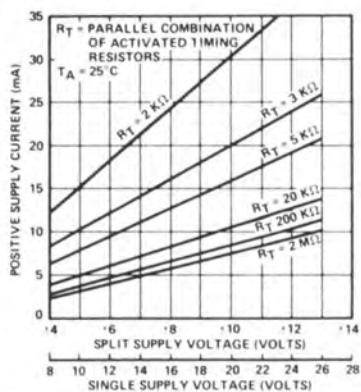

Figure 4. Positive Supply Current, I^+ (Measured at Pin 1) vs. Supply Voltage*

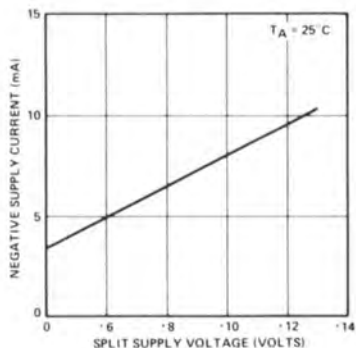

Figure 5. Negative Supply Current, I^- (Measured at Pin 12) vs. Supply Voltage

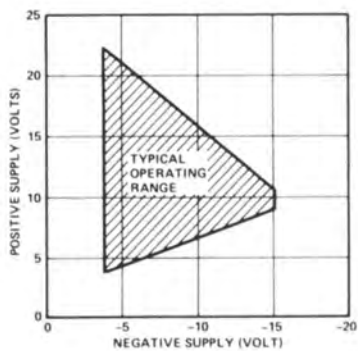

Figure 6. Typical Operating Range For Split Supply Voltage

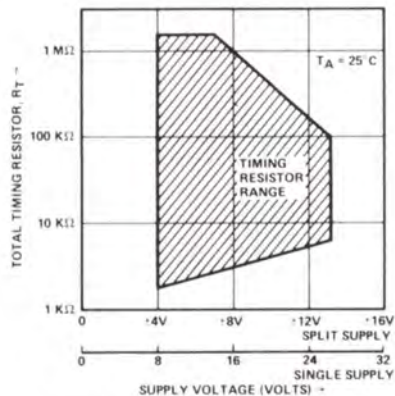

Figure 7. Recommended Timing Resistor Value vs. Power Supply Voltage*

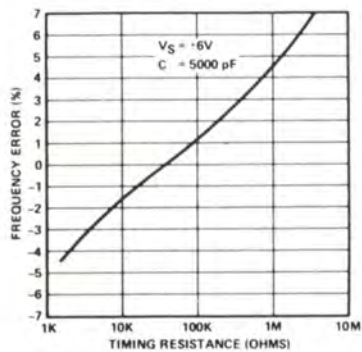

Figure 8. Frequency Accuracy vs. Timing Resistance

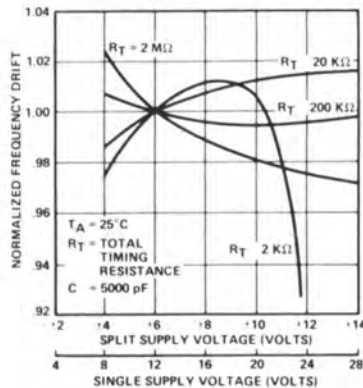

Figure 9. Frequency Drift vs. Supply Voltage

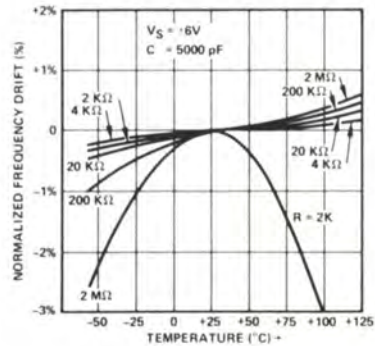

Figure 10. Normalized Frequency Drift With Temperature

*Note: R_T = Parallel Combination of Activated Timing Resistors

The circuit operates with supply voltages ranging from $\pm 4V$ to $\pm 13V$. Minimum drift occurs with ± 6 volt supplies. For operation with unequal supply voltages, see Figure 6.

LOGIC LEVEL		SELECTED TIMING PINS	FREQUENCY	DEFINITIONS
A	B			
0	0	6	f_1	$f_1 = 1/R_3C, \Delta f_1 = 1/R_4C$
0	1	6 and 7	$f_1 + \Delta f_1$	$f_2 = 1/R_2C, \Delta f_2 = 1/R_1C$
1	0	5	f_2	Logic Levels: 0 = Ground 1 = $\geq 3V$
1	1	4 and 5	$f_2 + \Delta f_2$	

Figure 11. Logic Table For Binary Keying Controls.
Note: For Single-Supply Operation, Logic Levels are Referenced to Voltage at Pin 10

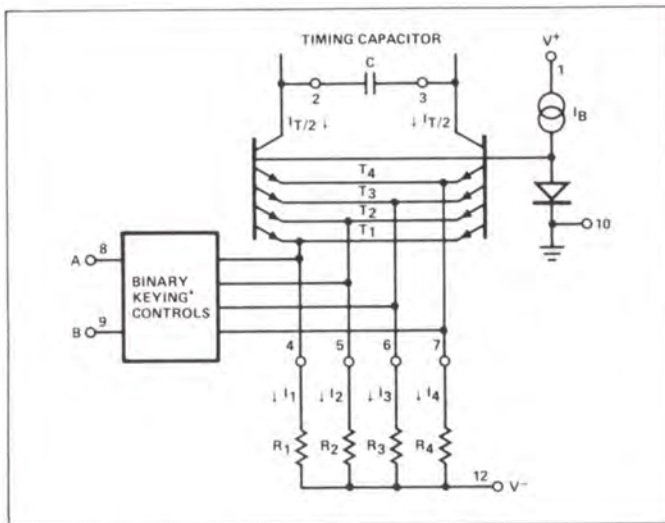

Figure 12. Simplified Schematic of Frequency Control Mechanism

The logic levels at the keying inputs (pins 8 and 9) are referenced to ground. A logic "0" corresponds to a keying voltage $V_k < 1.4V$, and a logic "1" corresponds to $V_k > 3V$. An open circuit at the keying inputs also corresponds to a "0" level.

SINGLE SUPPLY OPERATION

The circuit should be interconnected as shown in Figure 14 for single supply operation. Pin 12 should be grounded, and pin 11 biased from V^+ through a resistive divider to a value of bias voltage between $V^+/3$ and $V^+/2$. Pin 10 is bypassed to ground through a $1 \mu F$ capacitor.

For single supply operation, the dc voltage at pin 10 and the timing terminals (pins 4 through 7) are equal and approximately $0.6V$ below V_B , the bias voltage at pin 11. The logic levels at the binary keying terminals are referenced to the voltage at pin 10.

For a fixed frequency of $f_3 = 1/R_3C$, the external circuit connections can be simplified as shown in Figure 14b.

SELECTION OF EXTERNAL COMPONENTS

TIMING CAPACITOR (PINS 2 AND 3)

The oscillator frequency is inversely proportional to the timing capacitor, C , as indicated in Figure 11. The minimum capacitance value is limited by stray capacitances and the

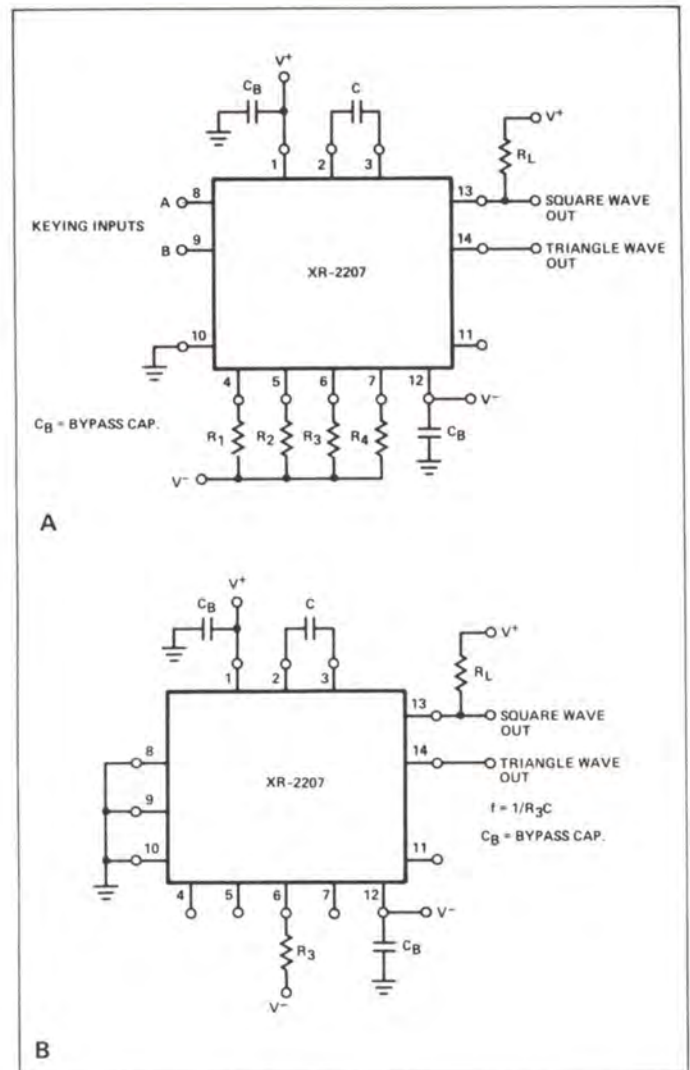

Figure 13. Split-Supply Operation:

- General
- Fixed Frequency

maximum value by physical size and leakage current considerations. Recommended values range from 100 pF to $100 \mu F$. The capacitor should be non-polar.

TIMING RESISTORS (PINS 4, 5, 6, AND 7)

The timing resistors determine the total timing current, I_T , available to charge the timing capacitor. Values for timing resistors can range from $2 \text{ K}\Omega$ to $2 \text{ M}\Omega$; however, for optimum temperature and power supply stability, recommended values are $4 \text{ K}\Omega$ to $200 \text{ K}\Omega$ (see Figures 7, 9, and 10). To avoid parasitic pick up, timing resistor leads should be kept as short as possible. For noisy environments, unused, or deactivated timing terminals should be bypassed to ground through $0.1 \mu F$ capacitors.

SUPPLY VOLTAGE (PINS 1 AND 12)

The XR-2207 is designed to operate over a power supply range of $\pm 4V$ to $\pm 13V$ for split supplies, or $8V$ to $26V$ for single supplies. At high supply voltages, the frequency sweep range is reduced (see Figures 6 and 7). Performance is optimum for $\pm 6V$, or $12V$ single supply operation.

BINARY KEYING INPUTS (PINS 8 AND 9)

The internal impedance at these pins is approximately $5 \text{ K}\Omega$. Keying levels are $< 1.4V$ for "zero" and $> 3V$ for "one" logic levels referenced to the dc voltage at pin 10 (see Figure 11).

BIAS FOR SINGLE SUPPLY (PIN 11)

For single supply operation, pin 11 should be externally biased to a potential between $V^+/3$ and $V^+/2$ volts (see Figure 14). The bias current at pin 11 is nominally 5% of the total oscillation timing current, I_T .

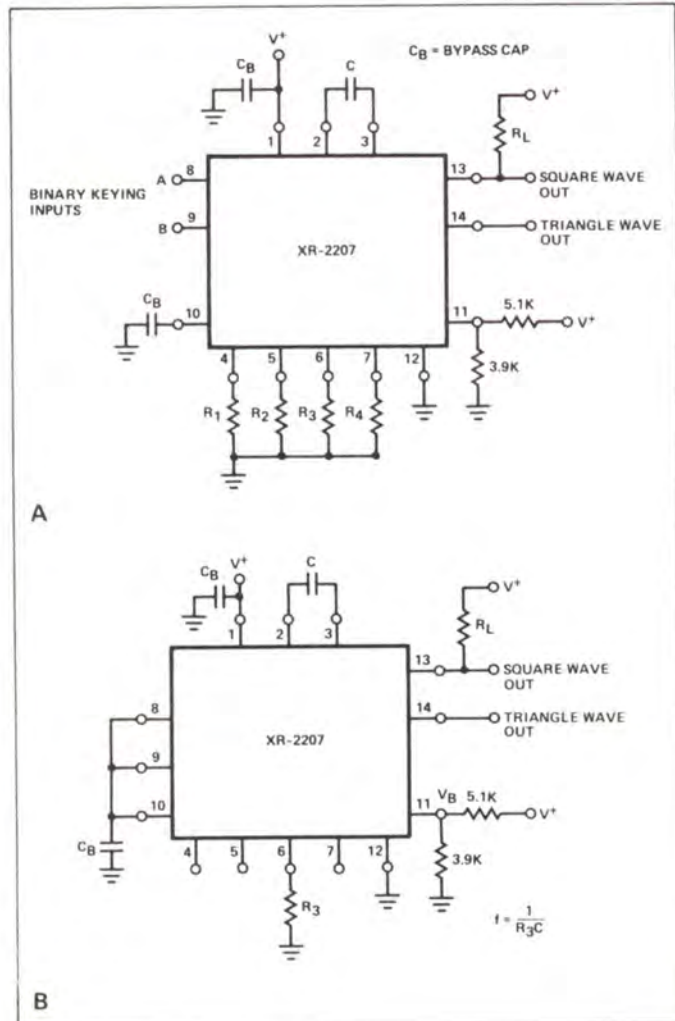

Figure 14. Single Supply Operation:
(a) General
(b) Fixed Frequency

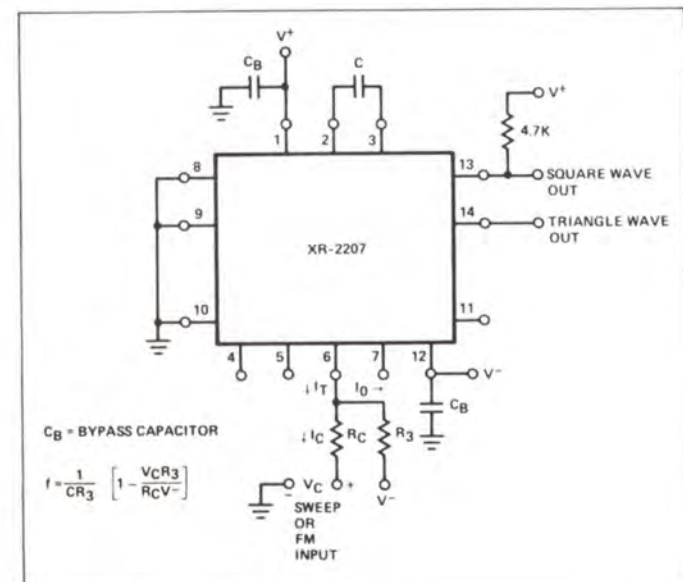

Figure 15. Frequency Sweep Operation

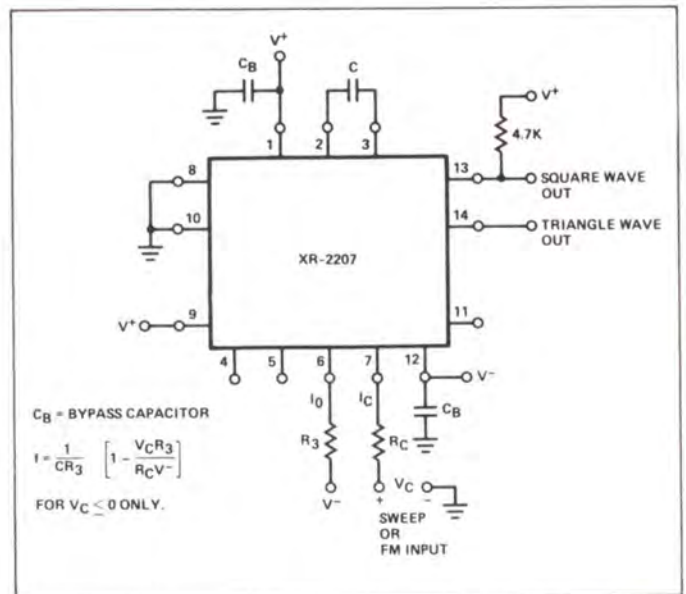

Figure 16. Alternate Frequency Sweep Operation

GROUND (PIN 10)

For split supply operation, this pin serves as circuit ground. For single supply operation, pin 10 should be ac grounded through a $1 \mu\text{F}$ bypass capacitor. During split supply operation, a ground current of $2I_T$ flows out of this terminal, where I_T is the total timing current.

SQUAREWAVE OUTPUT (PIN 13)

The squarewave output at pin 13 is a "open-collector" stage capable of sinking up to 20 mA of load current. R_L serves as a pull-up load resistor for this output. Recommended values for R_L range from 1 K Ω to 100 K Ω .

TRIANGLE OUTPUT (PIN 14)

The output at pin 14 is a triangle wave with a peak swing of approximately one-half of the total supply voltage. Pin 14 has a very low output impedance of 10 Ω and is internally protected against short circuits.

BYPASS CAPACITORS

The recommended value for bypass capacitors is $1 \mu\text{F}$, although larger values are required for very low frequency operation.

FREQUENCY CONTROL (SWEEP AND FM)

The frequency of operation is controlled by varying the total timing current, I_T , drawn from the activated timing pins 4, 5, 6, or 7. The timing current can be modulated by applying a control voltage, V_C , to the activated timing pin through a series resistor R_C as shown in Figures 15 and 16.

For split supply operation, a *negative* control voltage, V_C , applied to the circuits of Figures 15 and 16 causes the total timing current, I_T , and the frequency, to increase.

As an example, in the circuit of Figure 15, the binary keying inputs are grounded. Therefore, only timing pin 6 is activated.

The frequency of operation, normally $f = \frac{1}{R_3C}$, is now proportional to the control voltage, V_C , and determined as:

$$f = \frac{1}{R_3C} \left[1 - \frac{V_C R_3}{R_C V^-} \right] \text{ Hz}$$

The frequency f will increase as the control voltage is made more negative. If $R_3 = 2\text{ M}\Omega$, $R_C = 2\text{ K}\Omega$, $C = 5000\text{ pF}$, then a 1000:1 frequency sweep would result for a negative sweep voltage $V_C \approx V^-$

The voltage to frequency conversion gain, K , is controlled by the series resistance R_C and can be expressed as:

$$K = \frac{\Delta f}{\Delta V_C} = -\frac{1}{R_C C V^-} \text{ Hz/volt}$$

The circuit of Figure 15 can operate both with positive and negative values of control voltage. However, for positive values of V_C with small (R_C/R_3) ratio, the direction of the timing current I_T is reversed and the oscillations will stop.

Figure 16 shows an alternate circuit for frequency control where two timing pins, 6 and 7, are activated. The frequency and the conversion gain expressions are the same as before, except that the circuit would operate only with negative values of V_C . For $V_C > 0$, pin 7 becomes deactivated

and the frequency is fixed at $f = \frac{1}{R_3 C}$.

CAUTION

For operation of the circuit, total timing current I_T must be less than 6 mA over the frequency control range.

DUTY CYCLE CONTROL

The duty cycle of the output waveforms can be controlled by frequency shift keying at the end of every half cycle of oscillator output. This is accomplished by connecting one or both of the binary keying inputs (pins 8 or 9) to the squarewave output at pin 13. The output waveforms can then be converted to positive or negative pulses and sawtooth waveforms.

Figure 17 is the recommended circuit connection for duty cycle control. Pin 8 is shorted to pin 13 so that the circuit switches between the "0, 0" and the "1, 0" logic states given in Figure 11. Timing pin 5 is activated when the output is "high," and the timing pin is activated when the squarewave output goes to a low state.

The duty cycle of the output waveforms is given as:

$$\text{Duty Cycle} = \frac{R_2}{R_2 + R_3}$$

and can be varied from 0.1% to 99.9% by proper choice of timing resistors. The frequency of oscillation, f , is given as:

$$f = \frac{2}{C} \left[\frac{1}{R_2 + R_3} \right]$$

The frequency can be modulated or swept without changing the duty cycle by connecting R_2 and R_3 to a common control voltage V_C , instead of to V^- (see Figure 15). The sawtooth and the pulse output waveforms are shown in Figure 18.

ON – OFF KEYING

The XR-2207 can be keyed on and off by simply activating an open circuited timing pin. Under certain conditions, the circuit may exhibit very low frequency ($< 1\text{ Hz}$) residual oscillations in the "off" state due to internal bias currents. If this effect is undesirable, it can be eliminated by connecting a $10\text{ M}\Omega$ resistor from pin 3 to V^+ .

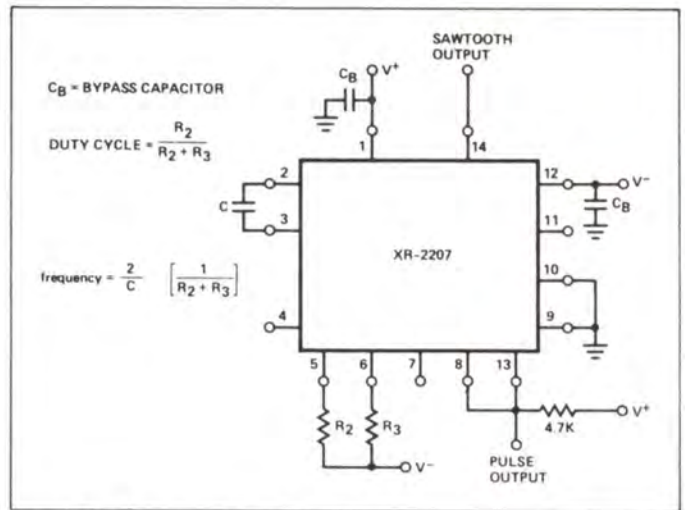

Figure 17. Sawtooth and Pulse Outputs

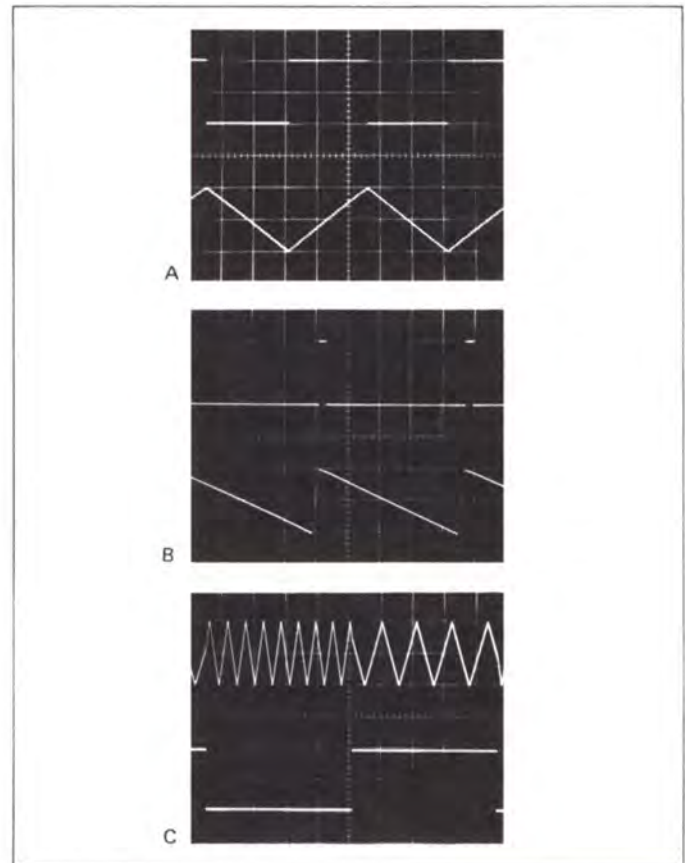

Figure 18. Output Waveforms:
 (a) Squarewave and Triangle Outputs
 (b) Pulse and Sawtooth Outputs
 (c) Frequency-Shift Keyed Output
 Top: FSK Output With $f_2 = 2f_1$
 Bottom: Keying Logic Input

TWO-CHANNEL FSK GENERATOR (MODEM TRANSMITTER)

The multi-level frequency shift-keying capability of XR-2207 makes it ideally suited for two-channel FSK generation. A recommended circuit connection for this application is shown in Figure 19.

For two-channel FSK generation, the "mark" and "space" frequencies of the respective channels are determined by the timing resistor pairs (R_1, R_2) and (R_3, R_4). Pin 8 is the

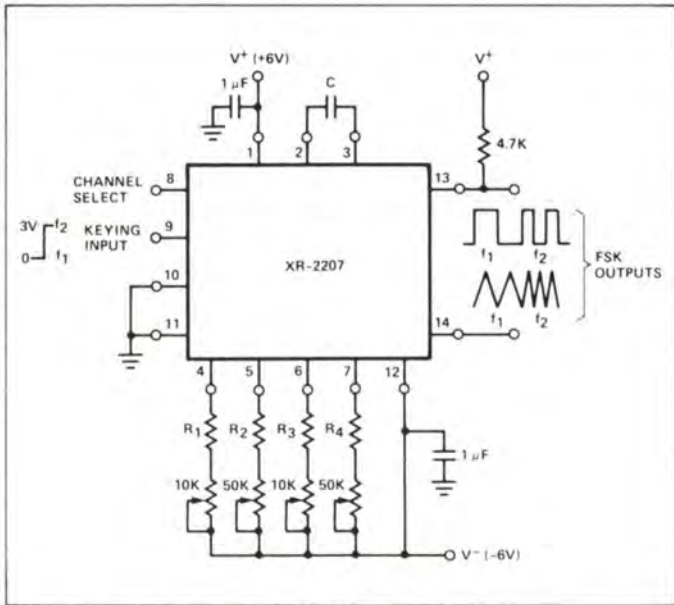

Figure 19. Multi-Channel FSK Generation

“channel-select” control in accord with Figure 11. For a “high” logic level at pin 8, the timing resistors R_1 and R_2 are activated. Similarly, for a “low” logic level, timing resistors R_3 and R_4 are enabled.

The “high” and “low” logic levels at pin 9 determine the respective high and low frequencies within the selected FSK channel.

Recommended component values for various commonly used FSK frequencies are given in Table I. When only a single FSK channel is used, the remaining channel can be deactivated by connecting pin 8 to either V^+ or ground. In this case, the unused timing resistors can also be omitted from the circuit.

OPERATING CONDITIONS	TYPICAL COMPONENT	VALUES
300 Baud	XR-210	XR-2207
Low Band: $f_1 = 1070$ Hz $f_2 = 1270$ Hz	$R_0 = 5.1$ k Ω , $C_0 = 0.22$ μ F $C_1 = C_2 = 0.047$ μ F, $C_3 = 0.033$ μ F	$R_3 = 91$ k $R_4 = 470$ k
High Band: $f_1 = 2025$ Hz $f_2 = 2225$ Hz	$R_0 = 8.2$ k Ω , $C_0 = 0.1$ μ F $C_1 = C_2 = C_3 = 0.033$ μ F	$R_3 = 47$ k $R_4 = 470$ k
1200 Baud $f_1 = 1200$ Hz $f_2 = 2200$ Hz	$R_0 = 2$ k Ω , $C_0 = 0.14$ μ F $C_1 = 0.033$ μ F, $C_3 = 0.02$ μ F $C_2 = 0.01$ μ F	$R_3 = 75$ k $R_4 = 91$ k

Table 1. Recommended Component Values for Full Duplex FSK Modem of Figure 20

The low and high frequencies, f_1 and f_2 , for a given FSK channel can be fine tuned using potentiometers connected in series with respective timing resistors. In fine tuning the frequencies, f_1 should be set first with the logic level at pin 9 in a “low” level.

Typical frequency drift of the circuit for 0°C to 75°C operation is $\pm 0.2\%$. Since the frequency stability is directly related to the external timing components, care must be taken to use timing components with low temperature coefficients.

FSK TRANCEIVER (FULL-DUPLEX MODEM)

The XR-2207 can be used in conjunction with the XR-210, FSK demodulator, to form a full-duplex FSK transceiver, or Modem. A recommended circuit connection for this application is shown in Figure 20. Table I shows the recommended component values for 300-Baud (103-type) and 1200-Baud (202-type) Modem applications.

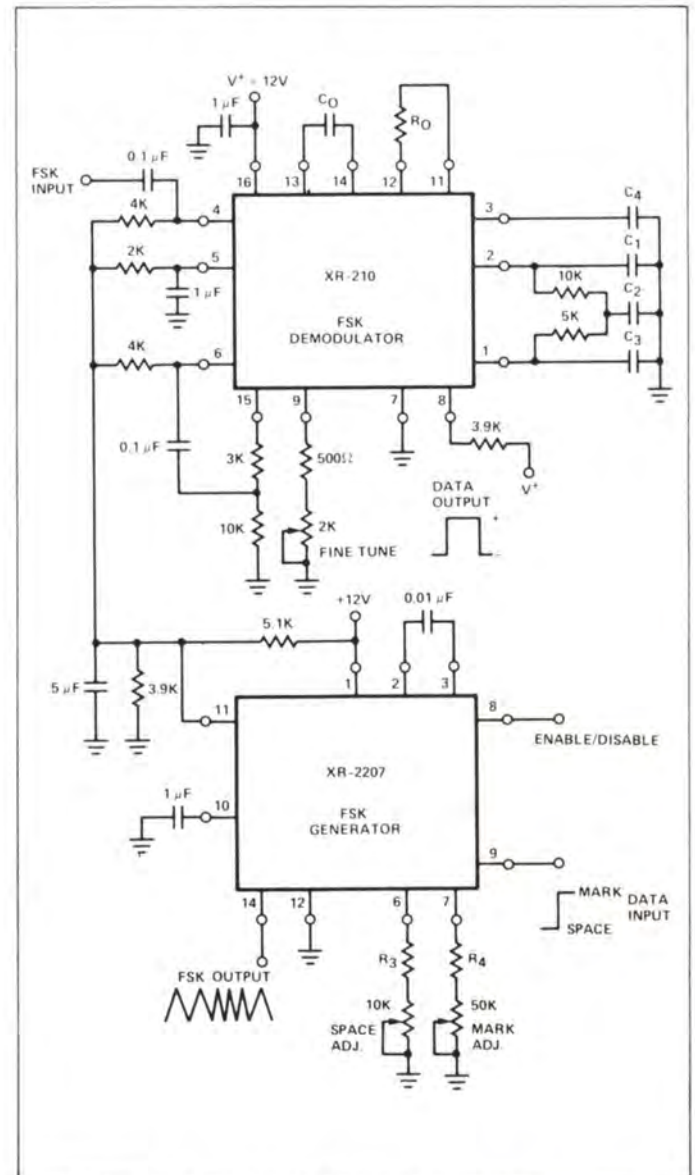

Figure 20. Full Duplex FSK Modem Using XR-210 and XR-2207 (See Table I For Component Values)

XR-2209

Precision Oscillator

GENERAL DESCRIPTION

The XR-2209 is a monolithic variable frequency oscillator circuit featuring excellent temperature stability and a wide linear sweep range. The circuit provides simultaneous triangle and squarewave outputs over a frequency range of 0.01 Hz to 1 MHz. The frequency is set by an external RC product. It is ideally suited for frequency modulation, voltage to frequency or current to frequency conversion, sweep or tone generation as well as for phase-locked loop applications when used in conjunction with a phase comparator such as the XR-2208.

The circuit is comprised of three functional blocks: a variable frequency oscillator which generates the basic periodic waveforms and two buffer amplifiers for the triangle and the squarewave outputs.

The oscillator frequency is set by an external capacitor, C, and the timing resistor R. With no sweep signal applied, the frequency of oscillation is equal to $1/RC$. The XR-2209 has a typical drift specification of 20 ppm/°C. Its frequency can be linearly swept over a 1000:1 range with an external control signal.

FEATURES

- Excellent Temperature Stability (20 ppm/°C)
- Linear Frequency Sweep
- Wide Sweep Range (1000:1 Min)
- Wide Supply Voltage Range ($\pm 4V$ to $\pm 13V$)
- Low Supply Sensitivity (0.15%/V)
- Wide Frequency Range (0.01 Hz to 1 MHz)
- Simultaneous Triangle and Squarewave Outputs

APPLICATIONS

- Voltage and Current-to-Frequency Conversion
- Stable Phase-Locked Loop
- Waveform Generation
- FM and Sweep Generation

ABSOLUTE MAXIMUM RATINGS

Power Supply	26 volts
Power Dissipation (package limitation)	
Ceramic package	385 mW
Plastic Package	300 mW
Derate above +25°C	2.5 mW/°C
Temperature Range	
Operating	
XR-2209M	-55°C to +125°C
XR-2209C	0°C to +75°C
Storage	-65°C to +150°C

AVAILABLE TYPES

Part Number	Package	Operating Temperature
XR-2209M	Ceramic	-55°C to +125°C
XR-2209CN	Ceramic	0°C to +75°C
XR-2209CP	Plastic	0°C to +75°C

EQUIVALENT SCHEMATIC DIAGRAM

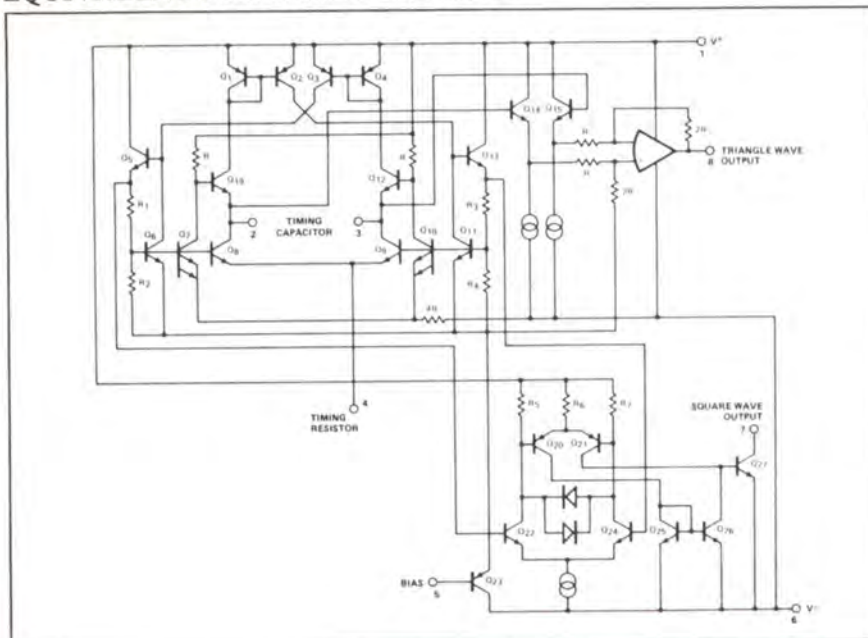

FUNCTIONAL BLOCK DIAGRAM

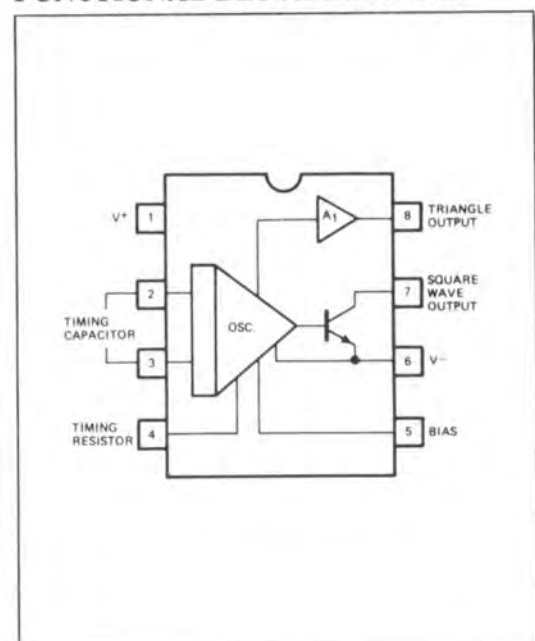

ELECTRICAL CHARACTERISTICS – PRELIMINARY

Test Conditions: Test Circuit of Figure 1, $V^+ = V^- = 6V$, $T_A = +25^\circ C$, $C = 5000\text{ pF}$, $R = 20\text{ K}\Omega$, $R_L = 4.7\text{ K}\Omega$.
 S_1 and S_2 closed unless otherwise specified.

PARAMETERS	XR-2209M			XR-2209C			UNITS	CONDITIONS
	MIN.	TYP.	MAX.	MIN.	TYP.	MAX.		
GENERAL CHARACTERISTICS								
Supply Voltage	8		26	8		26	V	See Figure 2
Single Supply	± 4		± 13	± 4		± 13	V	See Figure 1
Supply Current		5	7		5	8	mA	Measured at pin 1, S_1, S_2 open
Single Supply								See Figure 2
Split Supplies		5	7		5	8	mA	Measured at pin 1, S_1, S_2 open
Positive		4	6		4	7	mA	Measured at pin 4, S_1, S_2 open
Negative								
OSCILLATOR SECTION – FREQUENCY CHARACTERISTICS								
Upper Frequency Limit	0.5	1.0		0.5	1.0		MHz	$C = 500\text{ pF}$, $R = 2\text{ K}\Omega$
Lowest Practical Frequency		0.01			0.01		Hz	$C = 50\text{ }\mu\text{F}$, $R = 2\text{ M}\Omega$
Frequency Accuracy		± 1	± 3		± 1	± 5	% of f_O	
Frequency Stability								
Temperature		20	50		30		ppm/ $^\circ C$	$0^\circ < T_A < 75^\circ C$
Power Supply		0.15			0.15		%/V	
Sweep Range	1000:1	3000:1			1000:1		f_H/f_L	$R = 1.5\text{ K}\Omega$ for f_{H1} $R = 2\text{ M}\Omega$ for f_L
Sweep Linearity							%	$C = 5000\text{ pF}$
10:1 Sweep		1	2		1.5			$f_H = 10\text{ kHz}$, $f_L = 1\text{ kHz}$
1000:1 Sweep		5			5			$f_H = 100\text{ kHz}$, $f_L = 100\text{ Hz}$
FM Distortion		0.1			0.1		%	$\pm 10\%$ FM Deviation
Recommended Range of Timing Resistors	1.5		2000	1.5		2000	$K\Omega$	See Characteristic Curves
Impedance at Timing Pin		75			75		Ω	Measured at pin 4
OUTPUT CHARACTERISTICS								
Triangle Output								Measured at pin 8
Amplitude	4	6		4	6		V _{pp}	
Impedance		10			10		Ω	
Linearity		0.1			0.1		%	10% to 90% of swing
Squarewave Output								Measured at pin 7, S_2 closed
Amplitude	11	12		11	12		V _{pp}	
Saturation Voltage		0.2	0.4		0.2	0.4	V	Referenced to pin 6
Rise Time		200			200		nsec	$C_L \leq 10\text{ pF}$, $R_L = 4.7\text{ K}\Omega$
Fall Time		20			20		nsec	$C_L \leq 10\text{ pF}$

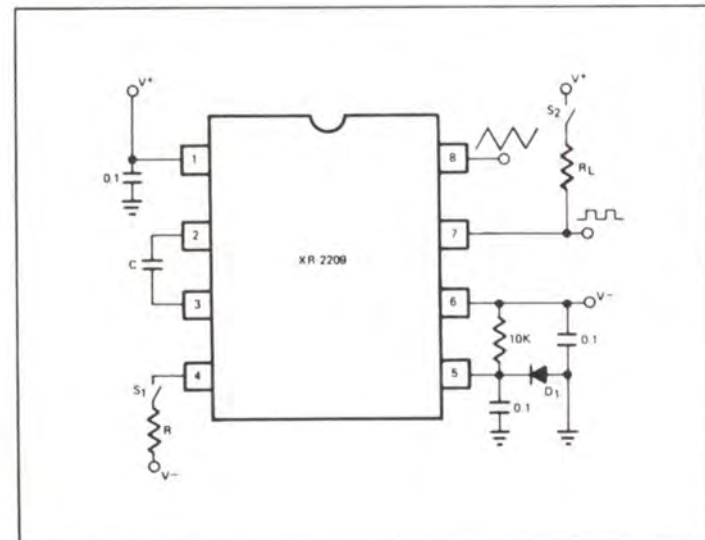

Figure 1. Test Circuit for Split Supply Operation ($D_1 = 1N\ 4148$ or Equivalent)

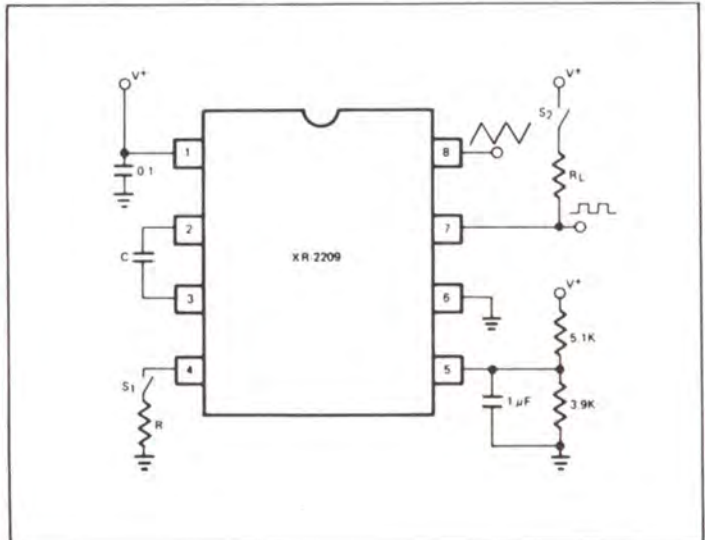

Figure 2. Test Circuit for Single Supply Operation

CHARACTERISTIC CURVES

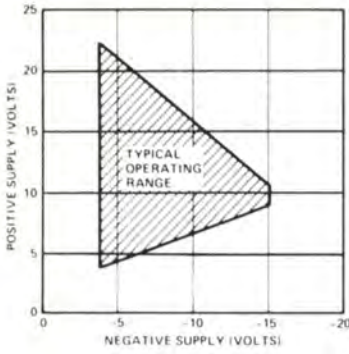

Figure 3. Typical Operating Range For Split Supply Voltage

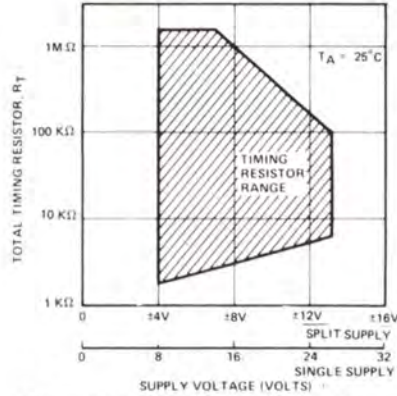

Figure 4. Recommended Timing Resistor Value vs. Power Supply Voltage*

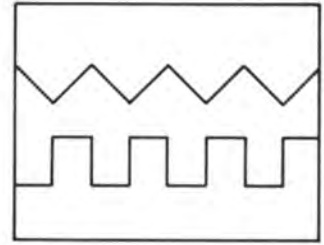

Figure 5: Output Waveforms
Top: Triangle Output (Pin 8)
Bottom: Squarewave Output (Pin 7)

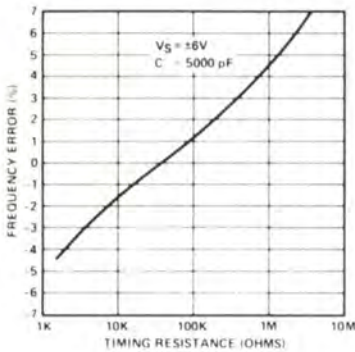

Figure 6. Frequency Accuracy vs. Timing Resistance

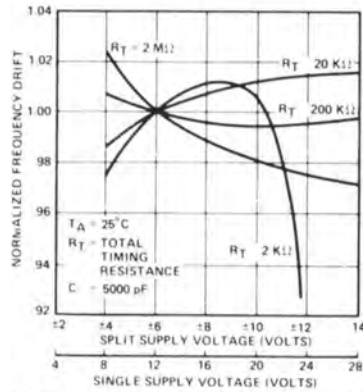

Figure 7. Frequency Drift vs. Supply Voltage

*Note: R_T = Timing Resistor at Pin 4

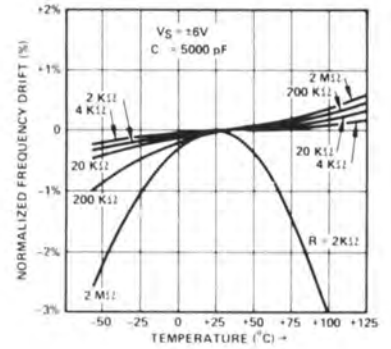

Figure 8. Normalized Frequency Drift With Temperature

RECOMMENDED CIRCUIT CONNECTIONS

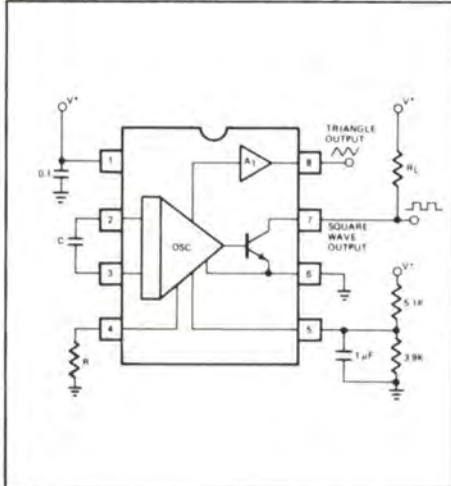

Figure 9. Circuit Connection for Single Supply Operation

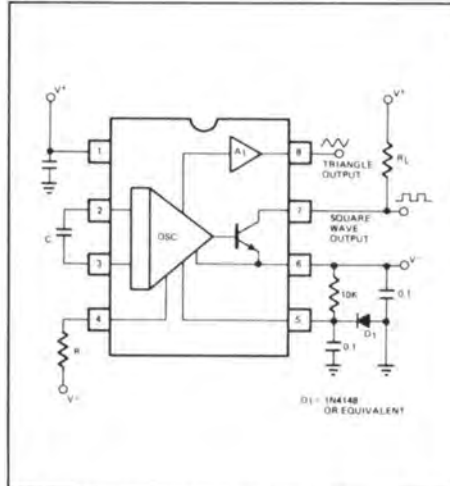

Figure 10. Generalized Circuit Connection for Split Supply Operation

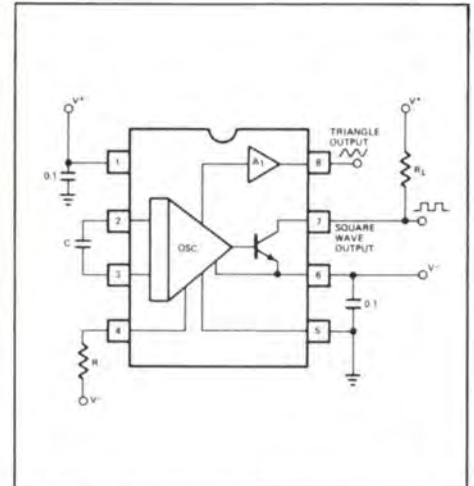

Figure 11. Simplified Circuit Connection for Split Supply Operation with $V_{CC} = V_{EE} > \pm 7V$ (Note: Triangle wave output has $+0.6V$ offset with respect to ground.)

PRECAUTIONS

The following precautions should be observed when operating the XR-2209 family of integrated circuits:

1. Pulling excessive current from the timing terminal will adversely effect the temperature stability of the circuit. To minimize this disturbance, it is recommended that the *total current* drawn from pin 4 be limited to ≤ 6 mA.

2. Terminals 2, 3, and 4 have very low internal impedance and should, therefore, be protected from accidental shorting to ground or the supply voltages.
3. Triangle waveform linearity is sensitive to parasitic coupling between the square and the triangle-wave outputs (pins 7 and 8). In board layout or circuit wiring care should be taken to minimize stray wiring capacitances between these pins.

DESCRIPTION OF CIRCUIT CONTROLS

TIMING CAPACITOR (PINS 2 and 3)

The oscillator frequency is inversely proportional to the timing capacitor, C . The minimum capacitance value is limited by stray capacitances and the maximum value by physical size and leakage current considerations. Recommended values range from 100 pF to 100 μ F. The capacitor should be non-polar.

TIMING RESISTOR (PIN 4)

The timing resistor determines the total timing current, I_T , available to charge the timing capacitor. Values for the timing resistor can range from 1.5 $K\Omega$ to 2 $M\Omega$; however, for optimum temperature and power supply stability, recommended values are 4 $K\Omega$ to 200 $K\Omega$ (see Figures 4, 7, and 8). To avoid parasitic pick up, timing resistor leads should be kept as short as possible.

SUPPLY VOLTAGE (PINS 1 AND 6)

The XR-2209 is designed to operate over a power supply range of $\pm 4V$ to $\pm 13V$ for split supplies, or 8V to 26V for single

supplies. At high supply voltages, the frequency sweep range is reduced (see Figures 3 and 4). Performance is optimum for $\pm 6V$, or 12V single supply operation.

BIAS FOR SINGLE SUPPLY (PIN 5)

For single supply operation, pin 5 should be externally biased to a potential between $V^+/3$ and $V^+/2$ volts (see Figure 9). The bias current at pin 5 is nominally 5% of the total oscillation timing current, I_T , at pin 4. This pin should be bypassed to ground with 0.1 μ F capacitor.

SQUAREWAVE OUTPUT (PIN 7)

The squarewave output at pin 7 is a "open-collector" stage capable of sinking up to 20 mA of load current. R_L serves as a pull-up load resistor for this output. Recommended values for R_L range from 1 $K\Omega$ to 100 $K\Omega$.

TRIANGLE OUTPUT (PIN 8)

The output at pin 8 is a triangle wave with a peak swing of approximately one-half of the total supply voltage. Pin 8 has a very low output impedance of 10 Ω and is internally protected against short circuits.

OPERATING INSTRUCTIONS

SPLIT SUPPLY OPERATION

The recommended circuit for split supply operation is shown in Figure 10. Diode D_1 in the figure assures that the triangle output swing at pin 8 is symmetrical about ground. This circuit operates with supply voltages ranging from $\pm 4V$ to $\pm 13V$. Minimum drift occurs at $\pm 6V$ supplies. See Figure 3 for operation with unequal supplies.

Simplified Connection

For operation with split supplies in excess of ± 7 volts, the simplified circuit connection of Figure 11 can be used. This circuit eliminates the diode D_1 used in Figure 10; however the triangle wave output at pin 8 now has a +0.6 volt DC offset with respect to ground.

SINGLE SUPPLY OPERATION

The recommended circuit connection for single-supply operation is shown in Figure 9. Pin 6 is grounded; and pin 5 is

biased from V^+ through a resistive divider, as shown in the figure, and is bypassed to ground with a 1 μ F capacitor.

For single supply operation, the DC voltage at the timing terminal, pin 4, is approximately 0.6 volts above V_B , the bias voltage at pin 5.

The frequency of operation is determined by the timing capacitor C and the timing resistor R , and is equal to $1/RC$. The squarewave output is obtained at pin 7 and has a peak-to-peak voltage swing equal to the supply voltage. This output is an "open-collector" type and requires an external pull-up load resistor (nominally 5 $K\Omega$) to V^+ . The triangle waveform obtained at pin 8 is centered about a voltage level V_O where:

$$V_O = V_B + 0.6V$$

where V_B is the bias voltage at pin 5. The peak-to-peak output swing of triangle wave is approximately equal to $V^+/2$.

FREQUENCY CONTROL (SWEEP AND FM)

The frequency of operation is proportional to the *total* timing current I_T drawn from the timing pin, pin 4. This timing current, and the frequency of operation can be modulated by applying a control voltage, V_C , to the timing pin, through a series resistor, R_S , as shown in Figure 12. If V_C is negative with respect to V_A , the voltage level at pin 4, then an additional current I_O is drawn from the timing pin causing I_T to increase, thus increasing the frequency. Conversely, making V_C higher than V_A causes the frequency to decrease by decreasing I_T .

The frequency of operation, is determined by:

$$f = f_0 \left[1 + \frac{R}{R_S} - \frac{V_C}{V_A} \frac{R}{R_S} \right]$$

where $f_0 = 1/RC$.

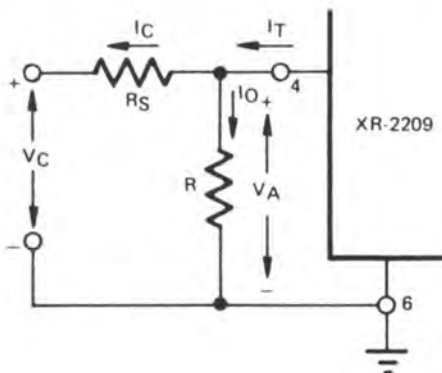

Figure 12. Frequency Sweep Operation

XR-8038

Precision Waveform Generator

GENERAL DESCRIPTION

The XR-8038 is a precision waveform generator IC capable of producing sine, square, triangular, sawtooth and pulse waveforms with a minimum number of external components and adjustments. Its operating frequency can be selected over nine decades of frequency, from 0.001 Hz to 1 MHz, by the choice of external R-C components. The frequency of oscillation is highly stable over a wide range of temperature and supply voltage changes. The frequency control, sweep and modulation can be accomplished with an external control voltage, without effecting the quality of the output waveforms. Each of the three basic waveforms, i.e. sinewave, triangle and square wave outputs are available simultaneously, from independent output terminals.

The XR-8038 monolithic waveform generator uses advanced processing technology and Schottky-barrier diodes to enhance its frequency performance. It can be readily interfaced with a monolithic phase-detector circuit, such as the XR-2208, to form stable phase-locked loop circuits.

FEATURES

- Direct Replacement for Intersil 8038
- Low Frequency Drift—50 ppm/°C Max.
- Simultaneous Sine, Triangle and Square-Wave Outputs
- Low Distortion—THD \approx 1%
- High FM and Triangle Linearity
- Wide Frequency Range — 0.001 Hz to 1 MHz
- Variable Duty-Cycle — 2% to 98%

APPLICATIONS

- Precision Waveform Generation Sine, Triangle, Square, Pulse Sweep and FM Generation
- Tone Generation
- Instrumentation and Test Equipment Design
- Precision PLL Design

ABSOLUTE MAXIMUM RATINGS

Power Supply	36V
Power Dissipation (package limitation)	
Ceramic package	750 mW
Derate above +25°C	6.0 mW/°C
Plastic package	625 mW
Derate above +25°C	5 mW/°C
Storage Temperature Range	-65°C to +150°C

AVAILABLE TYPES

Part Number	Package	Operating Temperature
XR-8038M	Ceramic	-55°C to +125°C
XR-8038N	Ceramic	0°C to +75°C
XR-8038P	Plastic	0°C to +75°C
XR-8038CN	Ceramic	0°C to +75°C
XR-8038CP	Plastic	0°C to +75°C

PACKAGE INFORMATION

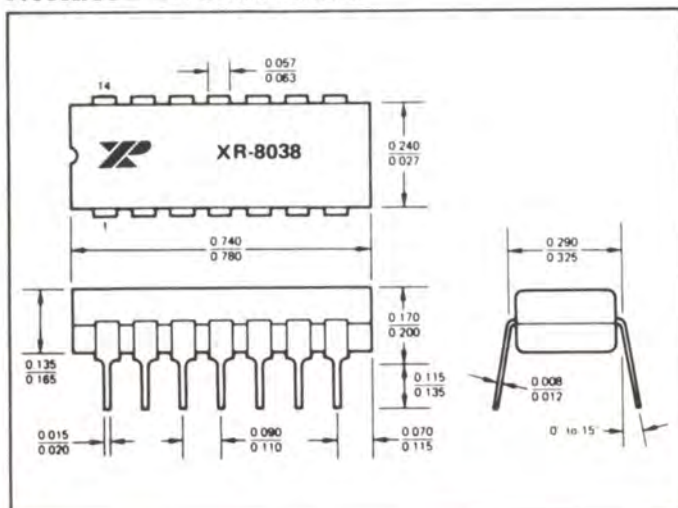

FUNCTIONAL BLOCK DIAGRAM

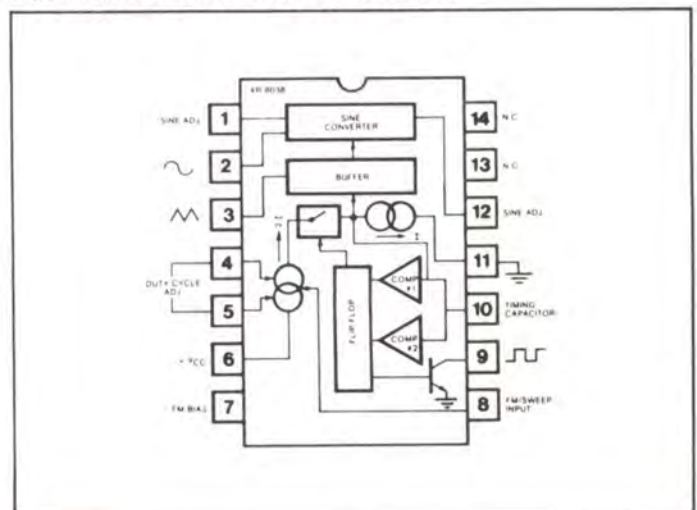

If You Didn't Get This From My Site,
Then It Was Stolen From...

ELECTRICAL CHARACTERISTICS

Test Conditions: $V_S = \pm 5V$ to $\pm 15V$, $T_A = 25^\circ C$, $R_L = 1 M\Omega$, $R_A = R_B = 10k\Omega$, $C_1 = 3300 pF$, S_1 closed, unless otherwise specified. See Test Circuit of Figure 1.

CHARACTERISTICS	XR-8038M/XR-8038			XR-8038C			UNITS	CONDITIONS
	MIN.	TYP.	MAX.	MIN.	TYP.	MAX.		
GENERAL CHARACTERISTICS								
Supply Voltage, V_S								
Single Supply	10		30	10		30	V	$V_S = \pm 10V$. See Note 1.
Dual Supplies	± 5		± 15	± 5		± 15	V	
Supply Current		12	15		12	20	mA	
FREQUENCY CHARACTERISTICS (Measured at Pin 9)								
Range of Adjustment								$R_A = R_B = 500\Omega$, $C_1 = 0$, $R_L = 15 k\Omega$ $R_A = R_B = 1 M\Omega$, $C_1 = 500 \mu F$ S_1 Open. See Notes 2 and 3. S_1 Open. See Note 3. Values of R_A and R_B . See Note 4.
Max. Operating Frequency		1			1		MHz	
Lowest Practical Frequency		0.001			0.001		Hz	
Max. FM Sweep Frequency		100			100		kHz	
FM Sweep Range		1000:1			1000:1			
FM Linearity		0.1			0.2		%	
Range of Timing Resistors	0.5		1000	0.5		1000	$k\Omega$	
Temperature Stability								
XR-8038M		20	50	—	—	—	ppm/ $^\circ C$	
XR-8038		50	100	—	—	—	ppm/ $^\circ C$	
XR-8038C	—	—	—		50		ppm/ $^\circ C$	
Power Supply Stability		0.05			0.05		%/V	
OUTPUT CHARACTERISTICS								
Square-Wave								Measured at Pin 9. $R_L = 100 k\Omega$ $I_{sink} = 2 mA$ $R_L = 4.7 k\Omega$ $R_L = 4.7 k\Omega$
Amplitude	0.9	0.98		0.9	0.98		$\times V_S$	
Saturation Voltage		0.2	0.4		0.2	0.5	V	
Rise Time		100			100		nsec	
Fall Time		40			40		nsec	
Duty Cycle Adj.	2		98	2		98	%	
Triangle/Sawtooth/Ramp								Measured at Pin 3. $R_L = 100 k\Omega$ $I_{out} = 5 mA$
Amplitude	0.3	0.33		0.3	0.33		$\times V_S$	
Linearity		0.05			0.1		%	
Output Impedance		200			200			
Sine-Wave Amplitude	0.2	0.22		0.2	0.22		$\times V_S$	$R_L = 100 k\Omega$ $R_L = 1 M\Omega$. See Note 5. $R_L = 1 M\Omega$
Distortion								
Unadjusted		0.7	1.5		0.8	3	%	
Adjusted		0.5			0.5		%	

Note 1: Currents through R_A and R_B not included.

Note 2: $V_S = 20V$, $f = 10 kHz$, $R_A = R_B = 10k\Omega$.

Note 3: Apply sweep voltage at Pin 8.

$$(2/3 V_S + 2V) \leq V_{sweep} \leq V_S$$

Note 4: $10V \leq V_S \leq 30V$ or $\pm 5V \leq V_S \leq \pm 15V$.

Note 5: $81 k\Omega$ resistor connected between Pins 11 and 12.

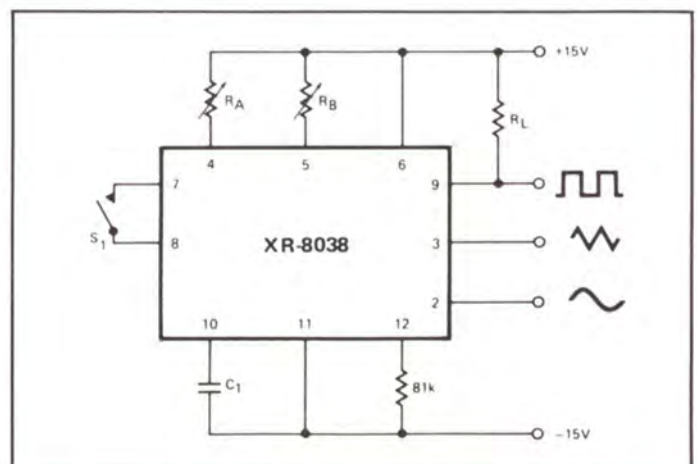
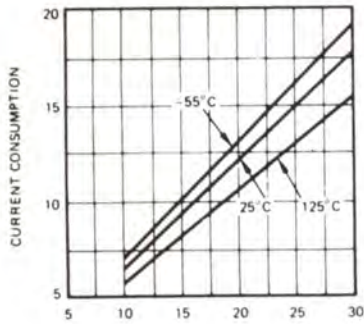
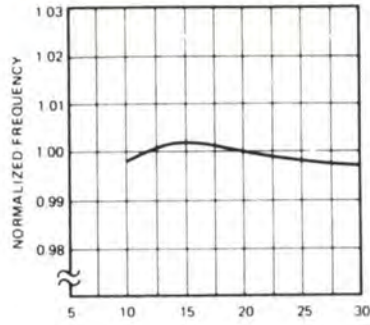

Figure 1. Generalized Test Circuit.

CHARACTERISTIC CURVES



Supply Voltage
Power Dissipation vs. Supply Voltage



Supply Voltage
Frequency Drift vs. Power Supply

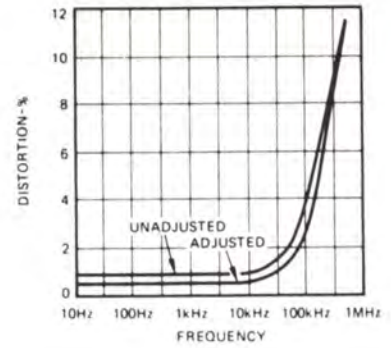

Sinewave THD vs. Frequency

WAVEFORM ADJUSTMENT

The *symmetry* of all waveforms can be adjusted with the external timing resistors. Two possible ways to accomplish this are shown in Figure 2. Best results are obtained by keeping the timing resistors R_A and R_B separate (a). R_A controls the rising portion of the triangle and sine-wave and the "Low" state of the square wave.

The magnitude of the triangle waveform is set at $1/3 V_{CC}$; therefore, the duration of the rising portion of the triangle is:

$$t_1 = \frac{C \times V}{I} = \frac{C \times 1/3 \times V_{CC} \times R_A}{1/5 \times V_{CC}} = \frac{5}{3} R_A \times C$$

The duration of the falling portion of the triangle and the sine-wave, and the "High" state of the square-wave is:

$$t_2 = \frac{C \times V}{I} = \frac{C \times 1/3 \times V_{CC}}{\frac{2}{5} \times \frac{V_{CC}}{R_B} - \frac{1}{5} \times \frac{V_{CC}}{R_A}} = \frac{5}{3} \times \frac{R_A R_B C}{2R_A - R_B}$$

Thus a 50% duty cycle is achieved when $R_A = R_B$.

If the duty-cycle is to be varied over a small range about 50% only, the connection shown in Figure 2b is slightly more convenient. If no adjustment of the duty cycle is desired, terminals

4 and 5 can be shorted together, as shown in Figure 2c. This connection, however, carries an inherently larger variation of the duty-cycle.

With two separate timing resistors, the *frequency* is given by

$$f = \frac{1}{t_1 + t_2} = \frac{1}{\frac{5}{3} R_A C \left(1 + \frac{R_B}{2R_A - R_B} \right)}$$

or, if $R_A = R_B = R$

$$f = 0.3/RC \quad (\text{for Figure 2a})$$

If a single timing resistor is used (Figures 2b and c), the frequency is

$$f = 0.15/RC$$

The frequency of oscillation is independent of supply voltage, even though none of the voltages are regulated inside the integrated circuit. This is due to the fact that both currents *and* thresholds are direct, linear function of the supply voltage and thus their effects cancel.

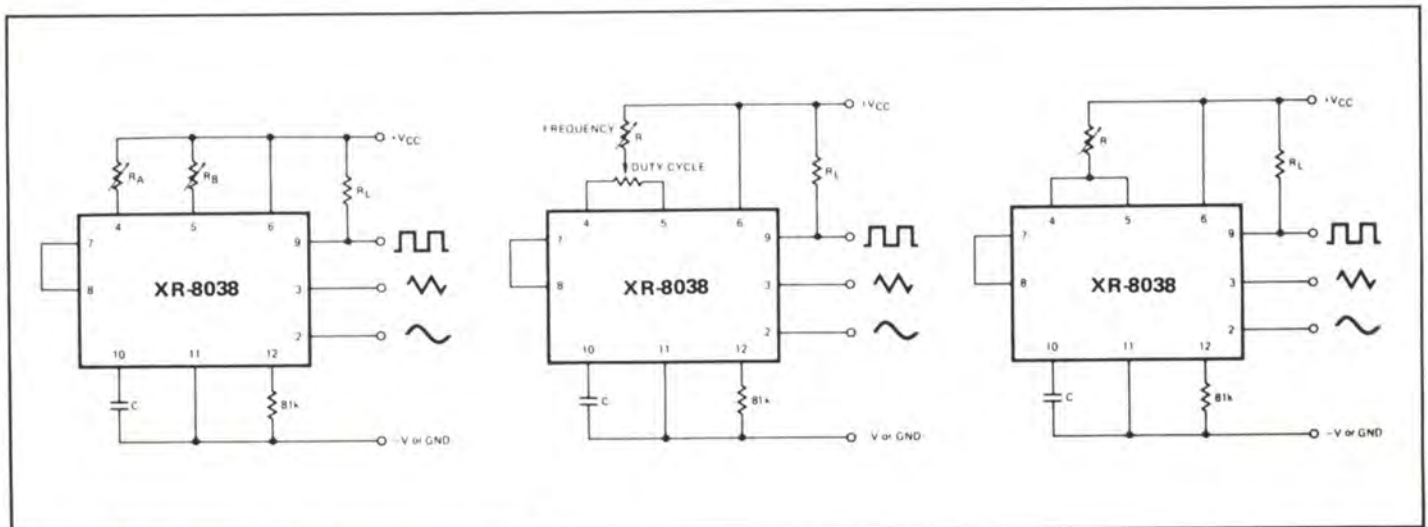

Figure 2. Possible Connections for the External Timing Resistors.

DISTORTION ADJUSTMENT

To minimize *sine-wave* distortion the 81 kΩ resistor between pins 11 and 12 is best made a variable one. With this arrangement distortion of less than 1% is achievable. To reduce this even further, two potentiometers can be connected as shown in Figure 3. This configuration allows a reduction of sine-wave distortion close to 0.5%.

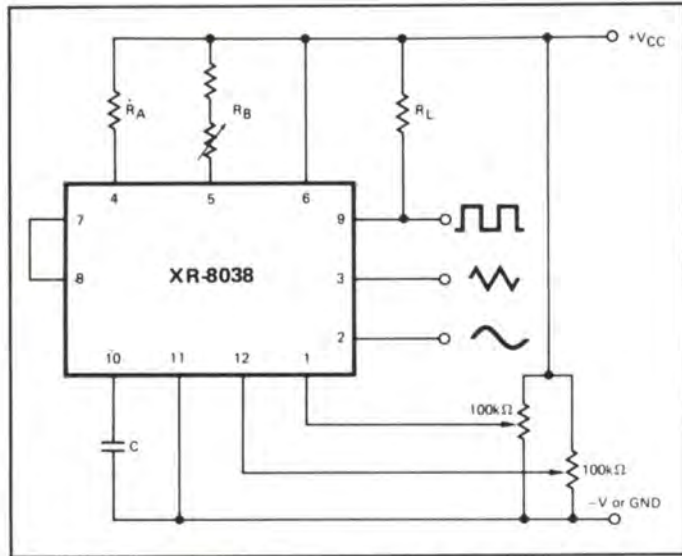

Figure 3. Connection to Achieve Minimum Sine-Wave Distortion.

SELECTING TIMING COMPONENTS

For any given output frequency, there is a wide range of RC combinations that will work. However certain constraints are placed upon the magnitude of the charging current for optimum performance. At the low end, currents of less than 0.1 μA are undesirable because circuit leakages will contribute significant errors at high temperatures. At higher currents ($I > 5$ mA), transistor betas and saturation voltages will contribute increasingly larger errors. Optimum performance will be obtained for charging currents of 1 μ to 1 mA. If pins 7 and 8 are shorted together the magnitude of the charging current due to R_A can be calculated from:

$$I = \frac{R_1 \times V_{CC}}{(R_1 + R_2)} \times \frac{1}{R_A} = \frac{V_{CC}}{5R_A}$$

A similar calculation holds for R_B .

SINGLE-SUPPLY AND SPLIT-SUPPLY OPERATION

The waveform generator can be operated either from a single power-supply (10 to 30 Volts) or a dual power-supply (± 5 to ± 15 Volts). With a single power-supply the average levels of the triangle and sine-wave are at exactly one-half of the supply voltage, while the square-wave alternates between + V_{CC} and ground. A split power supply has the advantage that all waveforms move symmetrically about ground.

The square-wave output is not committed. A load resistor can be connected to a different power-supply, as long as the applied voltage remains within the breakdown capability of the waveform generator (30V). In this way, the square-wave output will be TTL compatible (load resistor connected to +5 Volts) while the waveform generator itself is powered from a higher supply voltage.

FREQUENCY MODULATION AND SWEEP

The frequency of the waveform generator is a direct function of the DC voltage at terminal 8 (measured from + V_{CC}). By altering this voltage, frequency modulation is performed.

For small deviations (e.g. $\pm 10\%$) the modulating signal can be applied directly to pin 8 by merely providing ac coupling with a capacitor, as shown in Figure 4a. An external resistor between pins 7 and 8 is not necessary, but it can be used to increase input impedance. Without it (i.e. terminals 7 and 8 connected together), the input impedance is 8kΩ; with it, this impedance increases to $(R + 8k\Omega)$.

For larger FM deviations or for frequency sweeping, the modulating signal is applied between the positive supply voltage and pin 8 (Figure 4b). In this way the entire bias for the current sources is created by the modulating signal and a very large (e.g., 1000:1) sweep range is obtained ($f = 0$ at $V_{sweep} = 0$). Care must be taken, however, to regulate the supply voltage; in this configuration the charge current is no longer a function of the supply voltage (yet the trigger thresholds still are) and thus the frequency becomes dependent on the supply voltage. The potential on Pin 8 may be swept from V_{CC} to $2/3 V_{CC} + 2V$.

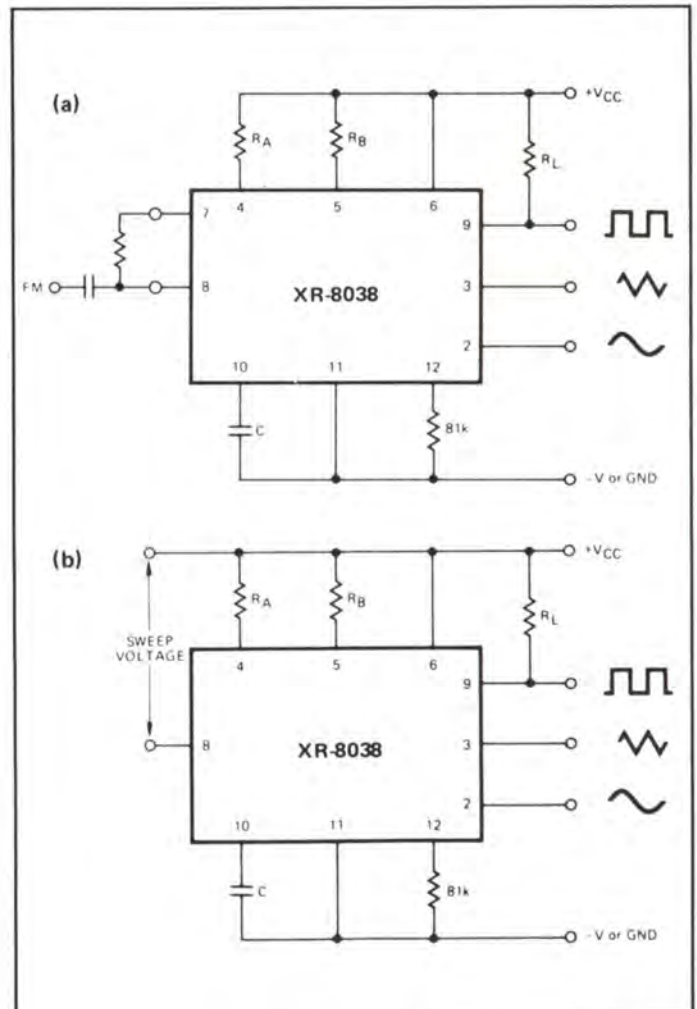

Figure 4. Connections for Frequency Modulation (a) and Sweep (b).

Stable FSK Modems Featuring the XR-2207, XR-2206 and XR-2211

INTRODUCTION

Frequency shift keying (FSK) is the most commonly-used method for transmitting digital data over telecommunications links. In order to use FSK, a modulator-demodulator (modem) is needed to translate digital 1's and 0's into their respective frequencies and back again.

This Applications Note describes the design of a modem using state-of-the-art Exar devices specifically intended for modem application.

The devices featured in this Application Note are the XR-2206 and XR-2207 FSK modulators, and the XR-2211 FSK demodulator with carrier-detect capability. Because of the superior frequency stability (typically 20 ppm/°C) of these devices, a properly designed modem using them will be virtually free of the temperature and voltage-dependent drift problems associated with many other designs. In addition, the demodulator performance is independent of incoming signal strength variation over a 60 dB dynamic range. Because bias voltages are generated internally, the external parts count is much lower than in most other designs. The modem designs shown in this Applications Note can be used with mark and space frequencies anywhere from several Hertz to 100 kiloHertz.

THE XR-2206 FSK MODULATOR

FEATURES

- Typically 20 ppm/°C temperature stability
- Choice of 0.5% THD sinewave, triangle, or squarewave output
- Phase-continuous FSK output
- Inputs are TTL and C/MOS compatible
- Low power supply sensitivity (0.01%/V)
- Split or single supply operation
- Low external parts count

OPERATION

The XR-2206 is ideal for FSK applications requiring the spectral purity of a sinusoidal output waveform. It offers TTL and C/MOS compatibility, excellent frequency stability, and ease of application. The XR-2206 can typically provide a 3 volt p-p sinewave output. Total harmonic distortion can be trimmed to 0.5%. If left untrimmed, it is approximately 2.5%.

The circuit connection for the XR-2206 FSK Generator is shown in Figure 1. The data input is applied to pin 9. A high level signal selects the frequency ($1/R_6C_3$) Hz; a low level signal selects the frequency ($1/R_7C_3$) Hz, (resistors in ohms and capacitors in farads). For optimum stability, R_6 and R_7 should be within the range of 10 kΩ to 100 kΩ. The voltage applied to pin 9 should be selected to fall between ground and V+.

Note: Over and under voltage may damage the device.

Potentiometers R_8 and R_9 should be adjusted for minimum total harmonic distortion. In applications where minimal distortion is unnecessary, pins 15 and 16 may be left open-circuited and R_8 may be replaced by a fixed 200Ω resistor. In applications where a triangular output waveform is satisfactory, pins 13 thru 16 may be left open-circuited.

The output impedance at pin 2 is about 600Ω with AC coupling normally be used.

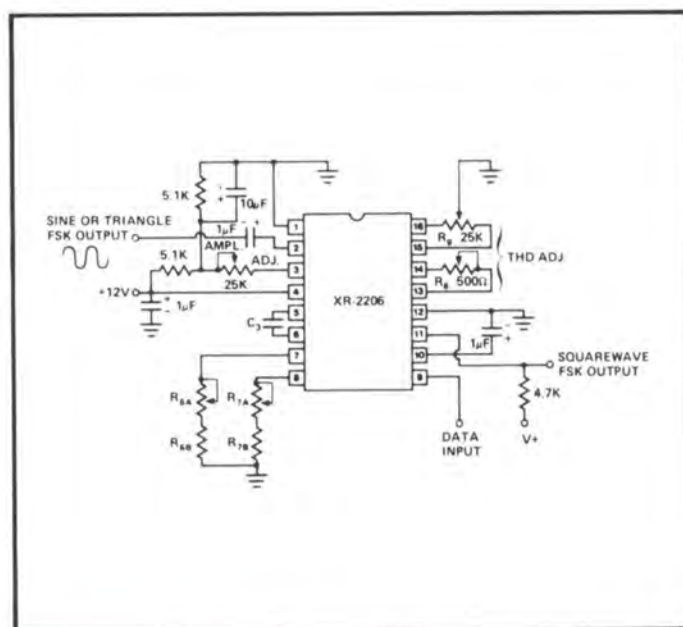

Figure 1. The XR-2206 Sinusoidal FSK Generator

THE XR-2207 FSK MODULATOR

FEATURES

- Typically 20 ppm/°C temperature stability
- Phase-continuous FSK output
- Provides both triangle and squarewave outputs
- Operates single-channel or two-channel multiplex
- Inputs are TTL and C/MOS compatible
- Split or single power supply operation
- Low power supply sensitivity (0.15%/V)
- Low external parts count

OPERATION

The XR-2207 is a stable FSK generator which is designed for those applications where only a triangle or squarewave output is required. It is capable of either single-channel or two-channel multiplex operation, and can be used easily with either split or single power supplies.

Figure 2 shows the XR-2207 using a single-supply and Figure 3 shows split-supply operation. When used as an FSK modulator pins 8 and 9 provide the digital inputs. When the 2207 is used with a split-supply, the threshold at these pins is approximately +2 volts, which is a level that is compatible with both TTL and C/MOS logic forms. When used with a single supply, the threshold is near mid-supply and is C/MOS compatible. Table 1 shows how to select the timing resistors R_1 thru R_4 to determine the output frequency based upon the logic levels applied to pins 8 and 9. For optimum stability, the values of R_1 and R_3 should be selected to fall between 10 kΩ and 100 kΩ.

With pin 8 grounded, pin 9 serves as the data input. A high level signal applied to pin 8 will disable the oscillator. When used in this manner, pin 8 of the XR-2207 serves as the channel select input. For two-channel multiplex operation, pins 4 and 5 should be connected as shown by the dotted lines. (For single channel operation, pins 4 and 5 should be left open-circuited.)

The XR-2207 provides two outputs; a squarewave at pin 13 and a trianglewave at pin 14. When used with a split-supply, the trianglewave peak-to-peak amplitude is equal to V_- and the dc level is near ground. Direct coupling is usually used. With a single-supply, the peak-to-peak amplitude is approximately equal to $\frac{1}{2}V_+$, the DC level is at approximately mid-supply and AC coupling is usually necessary. In either case, the output impedance is typically 10Ω and is internally protected against short circuits.

The squarewave output has an NPN open-collector configuration. When connected as shown in Figure 2 or 3 this output voltage will swing between V_+ and the voltage at pin 12.

Note: For safe operation, current into pin 13 should be limited to 20 mA.

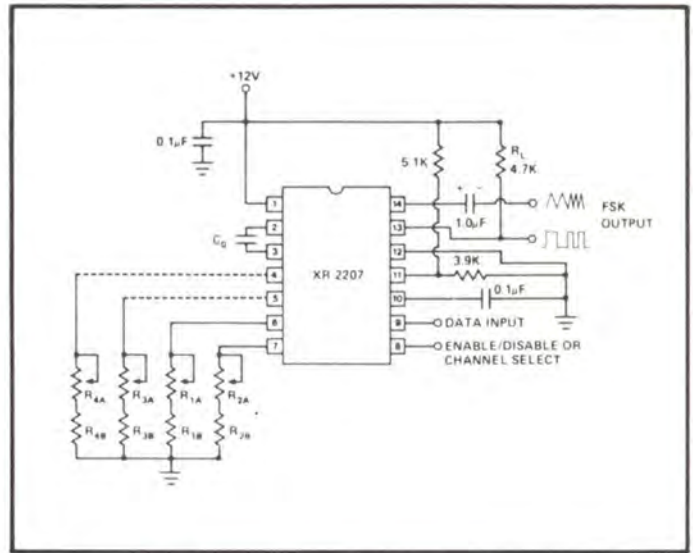

Figure 2. The XR-2207 FSK Modulator Single-Supply Operation

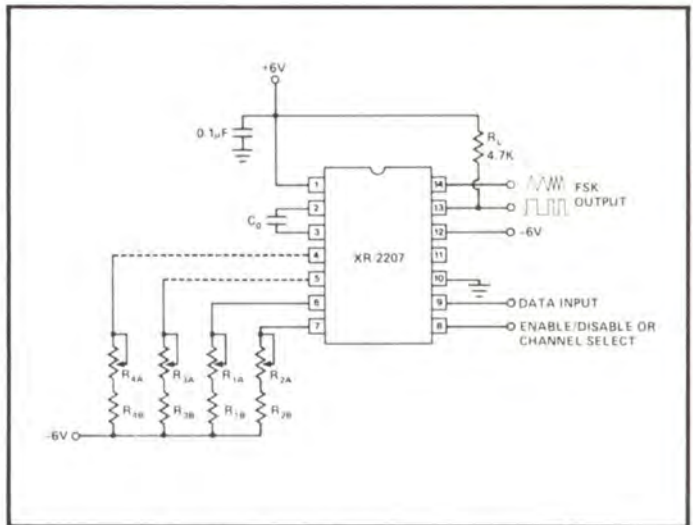

Figure 3. The XR-2207 FSK Modulator Split-Supply Operation

TABLE 1
XR-2207 FSK Input Control Logic

Logic Level		Active Timing Resistor	Output Frequency
Pin 8	Pin 9		
L	L	Pin 6	$\frac{1}{C_0 R_1}$
L	H	Pins 6 and 7	$\frac{1}{C_0 R_1} + \frac{1}{C_0 R_2}$
H	L	Pin 5	$\frac{1}{C_0 R_3}$
H	H	Pins 4 and 5	$\frac{1}{C_0 R_3} + \frac{1}{C_0 R_4}$

Units: Resistors – Ohms; Capacitors – Farads; Frequency – Hz

THE XR-2211 FSK DEMODULATOR WITH CARRIER DETECT

FEATURES

- Typically 20 ppm/°C temperature stability
- Simultaneous FSK and carrier-detect output
- Outputs are TTL and C/MOS compatible
- Wide dynamic range (2 mV to 3 Vrms)
- Split or single supply operation
- Low power supply sensitivity (0.05%/V)
- Low external parts count

OPERATION

The XR-2211 is a FSK demodulator which operates on the phase-locked-loop principle. Its performance is virtually independent of input signal strength variations over the range of 2 mV to 3 Vrms.

Figure 4 shows the circuit connection for the XR-2211. The center frequency is determined by $f_0 = (1/C_1 R_4)$ Hz, where capacitance is in farads and resistance is in ohms. F_0 should be calculated to fall midway between the mark and space frequencies.

The tracking range ($\pm\Delta f$) is the range of frequencies over which the phase-locked loop can retain lock with a swept input signal. This range is determined by the formula: $\Delta f = (R_4 f_0 / R_5)$ Hz. Δf should be made equal to, or slightly less than, the difference between the mark and space frequencies. For optimum stability, choose an R_4 between 10 k Ω and 100 k Ω .

The capture range ($\pm\Delta f_c$) is the range of frequencies over which the phase-locked loop can acquire lock. It is always less than the tracking range. The capture range is limited by C_2 , which, in conjunction with R_5 , forms the loop filter time constant. In most modem applications, $\Delta f_c = (80\% - 99\%) \Delta f$.

The loop damping factor (ξ) determines the amount of overshoot, undershoot, or ringing present in the phase-locked loop's response to a step change in frequency. It is determined by $\xi = \frac{1}{4} \sqrt{C_1 / C_2}$. For most modem applications, choose $\xi \approx \frac{1}{2}$.

The FSK output filter time constant (τ_F) removes chatter from the FSK output. The formula is: $\tau_F = R_F C_F$. Normally calculate τ_F to be approximately equal to $[0.3/(\text{baud rate})]$ seconds.

The lock-detect filter capacitor (C_D) removes chatter from the lock-detect output. With $R_D = 510$ k Ω , the minimum value of C_D can be determined by: $C_D (\mu\text{f}) \approx 16/\text{capture range in Hz}$.

Note: Excessive values of C_D will unnecessarily slow the lock-detect response time.

The XR-2211 has three NPN open collector outputs, each of which is capable of sinking up to 5 mA. Pin 7 is the FSK data output, Pin 5 is the Q lock-detect output, which goes low when a carrier is detected, and Pin 6 is the \bar{Q} lock detect output, which goes high when lock is detected. If pins 6 and 7 are wired together, the output signal from these terminals will provide data when FSK is applied and will be "low" when no carrier is present.

If the lock-detect feature is not required, pins 3, 5 and 6 may be left open-circuited.

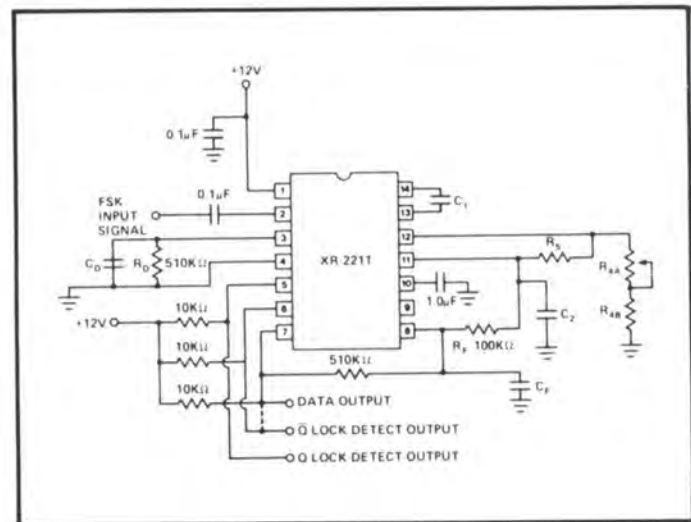

Figure 4. The XR-2211 FSK Demodulator with Carrier Detect

DESIGNING THE MODEM

Table 2 shows recommended component values for the three most commonly used FSK bands. In many instances, system constraints dictate the use of some non-standard FSK band. The XR-2206/XR-2207, XR-2211 combination is suitable for any range of frequencies from several Hertz to 100 kiloHertz.

Here are several guidelines to use when calculating non-standard frequencies:

- For maximum baud rate, choose the highest upper frequency that is consistent with the system bandwidth.
- The lower frequency must be at least 55% of the upper frequency. (Less than a 2:1 ratio)
- For minimum demodulated output pulsedwidth jitter, select an FSK band whose mark and space frequencies are

both high compared to the baud rate. (i.e., for a 300 baud channel, mark and space frequencies of 2025 Hz and 2225 Hz would result in significantly less pulsewidth jitter than 300 Hz and 550 Hz).

- For any given pair of mark and space frequencies, there is a limit to the baud rate that can be achieved. When maximum spacing between the mark and space frequencies is used (where the ratio is close to 2:1) the relationship

$$\frac{\text{mark-space frequency difference (Hz)}}{\text{maximum data rate (baud)}} \geq 83\%$$

should be observed.

For narrower spacing, the minimum ratio should be about 67%.

- The values shown in Table 2 may be scaled proportionately for mark and space frequencies, maximum baud rate, and (inversely) capacitor value. It is best to retain (approximately) the resistor values shown.

TABLE 2
Recommended Component Values for Typical FSK Bands

FSK Band			XR-2207					XR-2206					XR-2211						
Baud Rate	f_L	f_H	R_{1A} R_{3A}	R_{1B} R_{3B}	R_{2A} R_{4A}	R_{2B} R_{4B}	C_0	R_{6A}	R_{6B}	R_{7A}	R_{7B}	C_3	R_{4A}	R_{4B}	R_5	C_1	C_2	C_F	C_D
300	1070	1270	10	20	100	100	.039	10	18	10	20	.039	10	18	100	.039	.01	.005	.05
300	2025	2225	10	18	150	160	.022	10	16	10	18	.022	10	18	200	.022	.0047	.005	.05
1200	1200	2200	20	30	20	36	.022	10	16	20	30	.022	10	18	30	.027	.01	.0022	.01

Units: Frequency – Hz; Resistors – k Ω ; Capacitors – μ F

DESIGN EXAMPLES

A. Design a modem to handle a 10 kilobaud data rate, using the minimum necessary bandwidth.

1. Frequency Calculation

Because we want to use the minimum possible bandwidth (lowest possible upper frequency) we will use a 55:100 frequency ratio. The frequency difference, or 45% of the upper frequency, will be 83% of 10,000. We therefore choose an upper frequency:

$$\frac{83 \times 10,000}{45} = 18.444 \text{ kHz} \approx 18.5 \text{ kHz.}$$

and the lower frequency:

$$0.55 \times 18.5 \text{ kHz} = 10.175 \text{ kHz.}$$

2. Component Selection

- For the XR-2207 FSK modulator, set $R_1 \approx 30 \text{ k}\Omega$. Now, select a value of C_0 to generate 10.175 kHz with R_1 :

$$10.175 \text{ kHz} = 1/(C_0 \times 30,000); C_0 = 3300 \text{ pF.}$$

To choose R_2 :

$$18.500 \text{ kHz} - 10.175 \text{ kHz} = 8.325 \text{ kHz} = 1/C_0 R_2; R_2 = 36 \text{ k}\Omega.$$

A good choice would be to use 10 k Ω potentiometers for R_{1A} and R_{2A} , and to set $R_{1B} = 24 \text{ k}\Omega$ and $R_{2B} = 30 \text{ k}\Omega$.

- For the XR-2206, we can make R_7 equal to R_1 and C_3 equal to C_0 above. To determine R_6 :

$$18.5 \text{ kHz} = 1/R_6 C_3; R_6 = 16 \text{ k}\Omega.$$

Use a 10 k Ω potentiometer for R_{6A} and set $R_{6B} = 13 \text{ k}\Omega$.

- For the XR-2211 demodulator, we need to first determine R_4 and C_1 . First, $f_0 = (f_L + f_H)/2 = (10.175 + 18.500)/2 = 14.338 \text{ kHz}$. If we make $R_4 = 25 \text{ k}\Omega$, then $1/(C_1 \times 25,000) = 14,338$; $C_1 = 2790 \text{ pF} \approx 2700 \text{ pF}$. With that value of C_1 , the precise value of R_4 is now 25.8 k Ω . Select $R_{4B} = 18 \text{ k}\Omega$ and use a 10 k Ω for R_{4A} .

3. Frequency Component Selection

- To calculate R_5 , we first need our Δf , which is 18.500 – 10.175, or 8.325 kHz.

$$8325 = (25,800 \times 14,338)/R_5; R_5 = 44.4 \text{ k}\Omega \approx 47 \text{ k}\Omega.$$

- To determine C_2 use $\xi = \frac{1}{2} = \frac{1}{4} \sqrt{C_1/C_2}$. Then, $C_2 = \frac{1}{4} C_1$; $C_2 = 670 \text{ pF}$.

- To select C_F , we use $\tau_F = [0.3/(\text{baud rate})]$ seconds.

$$\tau_F = 0.3/10,000 = 30 \text{ }\mu\text{sec.};$$

with

$$R_F = 100 \text{ k}\Omega, C_F = 300 \text{ pF.}$$

4. Lock Range Selection

To select C_D , let us start with the actual lock range:

$$\Delta f = R_4 f_0 / R_5 \text{ Hz} = 7870 \text{ Hz.}$$

If we assume a capture range of 80%,

$$\Delta f_C = 6296 \text{ Hz};$$

therefore, our total capture range or $\pm \Delta f_C$ is 12,592 Hz. Our minimum value for C_D is $(16/12,592) \mu\text{f}$ or 0.0013 μf .

5. Completed Circuit Example

See Figure 5.

B. Design a 3 kilobaud modem to operate with low output jitter. The bandwidth available is 13 kHz.

For this modem, we can take the values from 2 for the 300 baud modem operating at 1070 Hz and 1270 Hz, multiply our baud rate and mark and space frequencies by 10, and divide all capacitor values on the table by 10. Resistor values should be left as they are.

C. Design a 2 channel multiplex FSK modulator to operate at the following pairs of mark and space frequencies: 600 Hz and 900 Hz, and 1400 and 1700 Hz. (Each of these channels could handle about 400 baud.)

For this task, we will use the XR-2207. The only real consideration here is that, if possible, we want to keep the following resistances all between 10 k Ω and 100 k Ω : R_1 , R_1/R_2 , R_3 and R_3/R_4 . The ratio between the maximum and minimum frequencies is less than 3:1, so we should have no trouble meeting this criterion. If we set our maximum frequency with an R of about 20 k Ω , we have: $1700 = 1/(C_0 \times 20,000)$; $C_0 = 0.029 \mu\text{f}$ which is approximately equal to 0.033 μf .

Calculating R_1 using 600 Hz and 0.033 μf , we get $R_1 = 50.5 \text{ k}\Omega$. We can use $R_{1B} = 47 \text{ k}\Omega$ and $R_{1A} = 10 \text{ k}\Omega$. For R_2 , we get 101 k Ω . Use $R_{2B} = 91 \text{ k}\Omega$ and $R_{2A} = 20 \text{ k}\Omega$. To determine R_3 , use: $1400 \text{ Hz} = 1/R_3 C_0$, which gives us $R_3 = 21.6 \text{ k}\Omega$. Use $R_{3B} = 18 \text{ k}\Omega$ and $R_{3A} = 5 \text{ k}\Omega$. R_4 must generate a 300 Hz shift in frequency, the same as R_2 . Therefore set R_4 equal to R_2 .

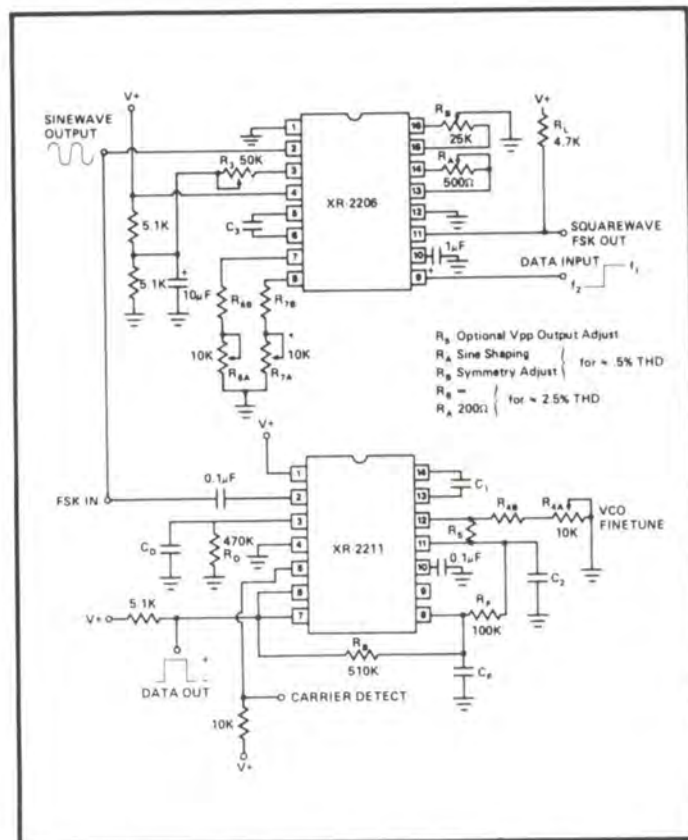

Figure 5. Full Duplex FSK Modem Using XR-2206 and XR-2211. (See Table 2 for Component Values.)

ADJUSTMENT PROCEDURE

The only adjustments that are required with any of the circuits in this application note are those for frequency fine tuning. Although these adjustments are fairly simple and straightforward, there are a couple of recommendations that should be followed.

The XR-2207: Always adjust the lower frequency first with R_{1B} or R_{3B} and a low level on pin 9. Then with a high level on pin 9, adjust the high frequency using R_{2B} or R_{4B} . The second adjustment affects only the high frequency, whereas the first adjustment affects both the low and the high frequencies.

The XR-2206: The upper and lower frequency adjustments are independent so the sequence is not important.

The XR-2211: With the input open-circuited, the loop phase detector output voltage is essentially undefined

and VCO frequency may be anywhere within the lock range. There are several ways that f_0 can be monitored:

1. Short pin 2 to pin 10 and measure f_0 at pin 3 with C_D disconnected;
2. Open R_5 and monitor pin 13 or 14 with a high-impedance probe; or
3. Remove the resistor between pins 7 and 8 and find the input frequency at which the FSK output changes state.

Note: Do NOT adjust the center frequency of the XR-2211 by monitoring the timing capacitor frequency with everything connected and no input signal applied.

For further information regarding the use of the XR-2207, XR-2206 and XR-2211 refer to the individual product data sheets.

Precision PLL System Using the XR-2207 and the XR-2208

INTRODUCTION

The phase-locked loop (PLL) is a versatile system block, suitable for a wide range of applications in data communications and signal conditioning. In most of these applications, the PLL is required to have a highly stable and predictable center frequency and a well-controlled bandwidth. Presently available monolithic PLL circuits often lack the frequency stability and the versatility required in these applications.

This application note describes the design and the application of two-chip PLL system using the XR-2207 and the XR-2208 monolithic circuits. The XR-2207 is a precision voltage controlled oscillator (VCO) circuit with excellent temperature stability (± 20 ppm/ $^{\circ}\text{C}$, typical) and linear sweep capability. The XR-2208 is an operational multiplier which combines a four quadrant multiplier and a high gain operational amplifier in the same package. Both circuits are designed to interface directly with each other with a minimum number of external components. Their combination functions as a high performance PLL, with the XR-2207 forming the VCO section of the loop, and the XR-2208 serving as the phase-detector and loop amplifier.

As compared with the presently available single-chip PLL circuits such as the XR-210 or the Harris HI-2820, the two-chip PLL system described in this paper offers approximately a factor of 10 improvement in temperature stability and center frequency accuracy. The system can operate from 0.01 Hz to 100 kHz, and its performance characteristics can be tailored to given design requirements with the choice of only four external components.

DEFINITIONS OF PLL PARAMETERS

The phase-locked loop (PLL) is a unique and versatile feedback system that provides frequency selective tuning and filtering without the need for coils or inductors. It consists of three basic functional blocks: phase comparator, low-pass filter, and voltage-controlled oscillator, interconnected as shown in Figure 1. With no input signal applied to the system, the error voltage, V_d , is equal to zero. The VCO operates at a set "free-running" frequency, f_0 . If an input signal is applied to the system, the phase comparator compares the phase and frequency of the input signal with the VCO frequency and generates an error voltage, $V_e(t)$, that is related to the phase and frequency difference between the two signals. This error voltage is then filtered and applied to the control terminal of the VCO. If the input signal frequency, f_s , is sufficiently close to f_0 , feedback causes the VCO to synchronize or "lock" with the incoming signal. Once in lock, the VCO frequency is identical to the input signal, except for a finite phase difference.

Two key parameters of a phase-locked loop system are its "lock" and "capture" ranges. These can be defined as follows:

Lock Range = The band of frequencies in the vicinity of f_0 over which the PLL can *maintain lock* with an input signal. It is also known as the "tracking" or "holding" range. Lock range increases as the overall loop gain of the PLL is increased.

Capture Range = The band of frequencies in the vicinity of f_0 where the PLL can *establish or acquire lock* with an input signal. It is also known as the "acquisition" range. The capture is always smaller than the lock range. It is related to the low pass filter bandwidth and decreases as the low pass filter time constant increased.

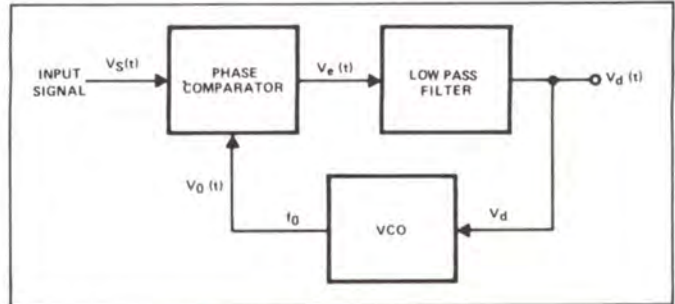

Figure 1. Block Diagram of a Phase-Locked Loop.

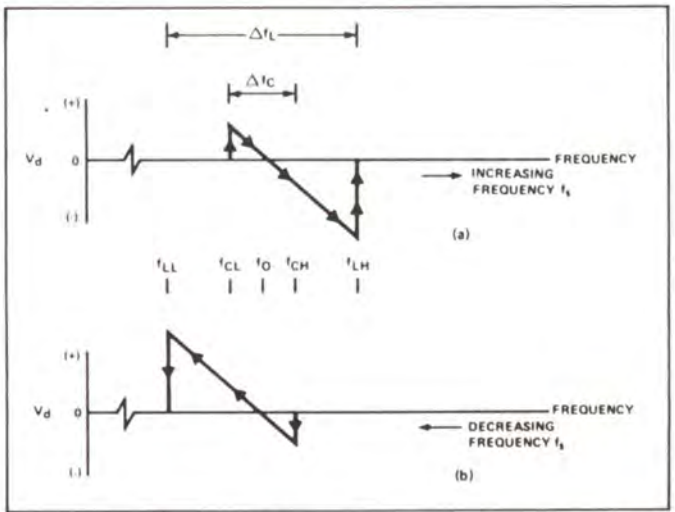

Figure 2. Frequency to Voltage Transfer Characteristics of a PLL System; (a) Increasing Input Frequency; (b) Decreasing Input Frequency.

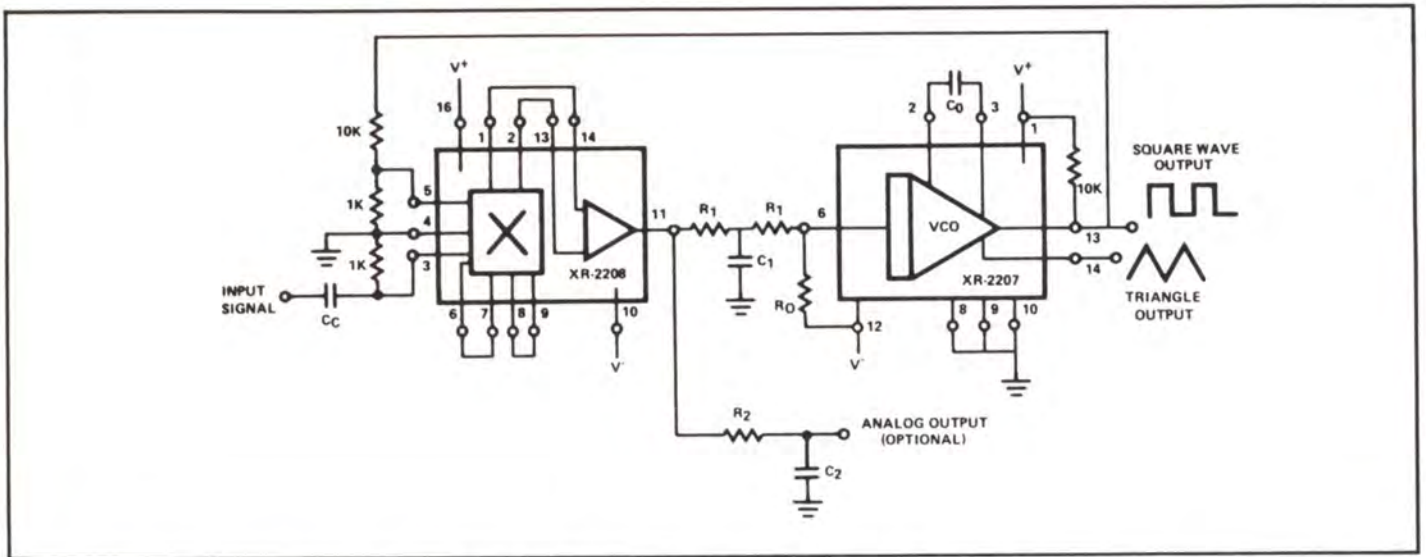

Figure 3. Circuit Interconnections for the Precision PLL System Using the XR-2207 and the XR-2208 Monolithic Circuits. (Split-supply operation, $\pm 6V$ to $\pm 13V$.)

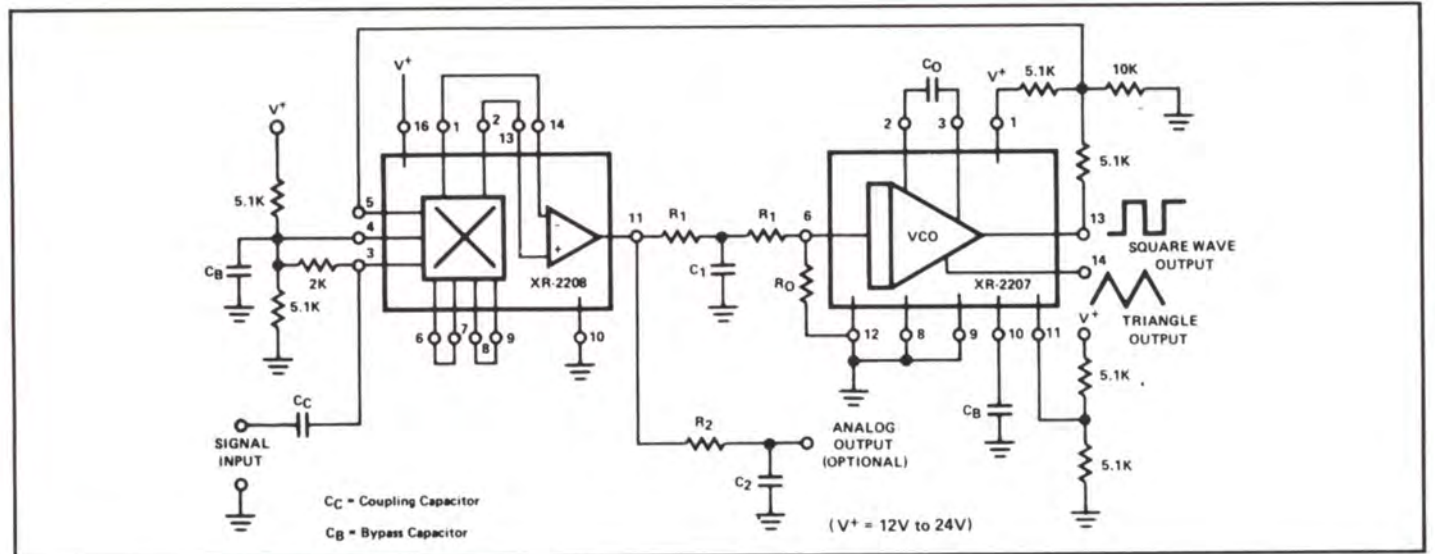

Figure 4. Circuit Interconnections for Single Supply Operation.

TABLE 1
Phase-Locked Loop Design Equations*

- | | |
|---|--|
| <p>(1) Center Frequency: $f_0 = \frac{1}{R_0 C_0}$ Hz</p> <p>(2) Lock Range: $(\Delta f_L / f_0) = (0.9)(R_0 / R_1)$</p> <p>(3) Phase Detector Gain: $K_\phi = 0.5 V_{cc}$ volts/radian
Where $V_{cc} = V^+$ for split supply; $V_{cc} = V^+ / 2$ for single supply.</p> <p>(4) VCO Conversion Gain: $K_v = \frac{1}{2 V_{cc} C_0 R_1}$ rad/sec/volt</p> <p>(5) Loop Gain: $K_L = K_\phi K_v = \frac{0.25}{C_0 R_1}$ sec⁻¹</p> <p>(6) Low Pass Filter Time Constant: $\tau = \frac{C_1 R_1}{2}$ sec.</p> | <p>(7) Loop Damping: $\xi = \frac{1}{2\sqrt{\tau K_L}} = \sqrt{\frac{2 C_0}{C_1}}$</p> <p>(8) Capture Range:</p> <p>a) Underdamped Loop ($\xi < 1/2$):</p> $(\Delta f_c / f_0) = \frac{0.8 R_0}{R_1} \sqrt{\frac{C_0}{C_1}}$ <p>b) Overdamped Loop ($\xi > 1$):</p> $(\Delta f_c / f_0) = 0.8(R_0 / R_1)$ |
|---|--|

*See Figures 3 and 4 for component designation.

The PLL responds only to those input signals sufficiently close to the VCO frequency, f_0 , to fall within the "lock" or "capture" ranges of the system. Its performance characteristics, therefore, offer a high degree of frequency selectivity, with the selectivity characteristics centered about f_0 . Figure 2 shows the typical frequency-to-voltage transfer characteristics of the PLL. The input is assumed to be a sine wave whose frequency is swept slowly, over a broad frequency range covering both the "lock" and the "capture" ranges of the PLL. The vertical scale corresponds to the filtered loop error voltage, V_d , appearing at the VCO control terminal.

As the input frequency, f_s , is swept up (Figure 2(a)) the system does not respond to the input signal until the input frequency reaches the lower end of capture range, f_{CL} . Then, the loop suddenly locks on the input signal, causing a positive jump in the error voltage V_d . Next, V_d varies at a slope equal to the reciprocal of VCO voltage-to-frequency conversion gain, (K_v), and goes through zero at $f_s = f_0$. The loop tracks the input frequency until f_s reaches the upper edge of the lock range, f_{LH} . Then the PLL loses lock, and the error voltage drops to zero. If the input frequency is swept back slowly, from high towards low frequencies the cycle repeats itself, with the characteristics shown in Figure 2(b). The loop captures the signal at the upper edge of the capture range, f_{CH} , and tracks it down the lower edge of the lock range, f_{LL} . With reference to the figure, the "lock" and the "capture" ranges can be defined as:

$$\text{Lock Range} = \Delta f_L = f_{LH} - f_{LL}$$

$$\text{Capture Range} = \Delta f_C = f_{CH} - f_{CL}$$

The gain parameters associated with the PLL are defined as follows:

Phase Detector Gain, $K\phi$: Phase detector output per unit of phase difference between the two signals appearing at the phase detector inputs. It is normally measured in volts per radian.

VCO Conversion Gain, K_v : VCO frequency change per unit of input voltage. It is normally measured in radians/sec./volt.

Loop Gain, K_L : Total d_c gain around the feedback loop. It is equal to the product of $K\phi$ and K_v .

Loop Damping Factor, ζ : Defines the response of the loop error voltage V_d , to a step change in frequency. If $\zeta < 1$, the loop is underdamped; and the error voltage V_d will exhibit an underdamped response for a step change of signal frequency.

The lock range of the phase-locked loop is controlled by the loop gain, K_L . The capture range and the damping factor are controlled by both the loop gain and the low pass filter.

PRECISION PLL USING XR-2207 AND XR-2208

The XR-2207 VCO and the XR-2208 operational multiplier can be inter-connected as shown in Figure 3, to form a highly stable PLL system. The circuit of Figure 3 operates with supply voltages in the range of ± 6 volts to ± 13 volts; and over a frequency range of 0.01 Hz to 100 kHz. In the PLL system of Figure 3, all the basic performance characteristics of the PLL can be controlled and adjusted by the choice external 4 components identified as resistors R_0 and R_1 , and the capacitors C_0 and C_1 . C_0 and R_0 control the VCO center frequency; R_1 and C_1 determine the tracking range and the low pass filter characteristics. The two-chip PLL system can be readily converted to single supply operation by inter-connecting the circuit as shown in Figure 4. The PLL circuit of Figure 4 operates over a supply voltage range of +12V to +26V.

For best results, the timing resistor R_0 should be in the range of 5k to 100k, and $R_1 > R_0$. Under these conditions, the basic parameters of the PLL can be easily calculated from the design equations listed in Table 1.

Design Example

As an example, consider the design of a PLL system using the circuit of Figure 3, to meet the following nominal performance specifications:

- a) Center Frequency = 10 kHz
- b) Tracking Range = 20% (9 kHz to 11 kHz)
- c) Capture Range = 10% (9.5 kHz to 10.5 kHz)

Solution:

- a) Set Center Frequency:
Choose $R_0 = 10k$ (Arbitrary choice for $5k < R_0 < 100k$)
Then, from equation 1 of Table 1:
 $C_0 = (1/f_0 R_0) = 0.01 \mu F$
- b) Set Lock Range:
From equation 2 of Table 1:
 $R_1 = (0.45) R_0 = 45k$
- c) Set Capture Range:
Since capture range is significantly smaller than Lock range, equation 8(a) applies.
Solving equation 8(a) for C_1 , one obtains:
 $C_1 = 0.032 \mu F$

A High Quality Function Generator System Using the XR-2206

INTRODUCTION

Waveform or function generators capable of producing AM/FM modulated sine wave outputs find a wide range of applications in electrical measurement and laboratory instrumentation. This application note describes the design, construction and the performance of such a complete function generator system suitable for laboratory usage or hobbyist applications. The entire function generator is comprised of a single XR-2206 monolithic IC and a limited number of passive circuit components. It provides the engineer, student, or hobbyist with highly versatile laboratory instrument for waveform generation at a very small fraction of the cost of conventional function generators available today.

GENERAL DESCRIPTION

The basic circuit configuration and the external components necessary for the high-quality function generator system is shown in Figure 1. The circuit shown in the figure is designed to operate with either a 12V single power supply, or with a $\pm 6V$ split supplies. For most applications, split-supply operation is preferred since it results in an output DC level which is nearly at ground potential.

The circuit configuration of Figure 1 provides three basic waveforms: sine, triangle and square wave. There are four overlapping frequency ranges which give an overall frequency range of 1 Hz to 100 kHz. In each range, the frequency may be varied over a 100:1 tuning range.

The sine or triangle output can be varied from 0 to over 6V (peak to peak) from a 600 ohm source at the output terminal.

A squarewave output is available at the sync output terminal for oscilloscope synchronizing or driving logic circuits.

TYPICAL PERFORMANCE CHARACTERISTICS

The performance characteristics listed below are not guaranteed or warranted by Exar. However, they represent the typical performance characteristics measured by Exar's application engineers during the laboratory evaluation of the function generator system shown in Figure 1. The typical performance specifications listed below apply *only* when all of the recommended assembly instructions and adjustment procedures are followed:

- (a) **Frequency Ranges:** The function generator system is designed to operate over four overlapping frequency ranges:

- 1 Hz to 100 Hz
- 10 Hz to 1 kHz
- 100 Hz to 10 kHz
- 1 kHz to 100 kHz

The range selection is made by switching in different timing capacitors.

- (b) **Frequency Setting:** At any range setting, frequency can be varied over a 100:1 tuning range with a potentiometer (see R₁₃ of Figure 1).

- (c) **Frequency Accuracy:** Frequency accuracy of the XR-2206 is set by the timing resistor R and the timing capacitor C, and is given as:

$$f = 1/RC$$

The above expression is accurate to within $\pm 5\%$ at any range setting. The timing resistor R is the series combination of resistors R₄ and R₁₃ of Figure 1. The timing capacitor C is any one of the capacitors C₃ through C₆, shown in the figure.

- (d) **Sine and Triangle Output:** The sine and triangle output amplitudes are variable from 0V to 6 V_{pp}. The amplitude is set by an external potentiometer, R₁₂ of Figure 1. At any given amplitude setting, the triangle output amplitude is approximately twice as high as the sinewave output. The internal impedance of the output is 600 Ω .

- (e) **Sinewave Distortion:** The total harmonic distortion of sinewave is less than 1% from 10 Hz to 10 kHz and less than 3% over the entire frequency range. The selection of a waveform is made by the triangle/sine selector switch, S₂.

- (f) **Sync Output:** The sync output provides a 50% duty cycle pulse output with either full swing or upper half swing of the supply voltage depending on the choice of sync output terminals on the printed circuit board (see Figure 1).

- (g) **Frequency Modulation (External Sweep):** Frequency can be modulated or swept by applying an external control voltage to sweep terminal (Terminal I of Figure 1). When not used, this terminal should be left open-circuited. The open circuit voltage at this terminal is approximately 3V above the negative supply voltage and its impedance is approximately 1000 ohms.

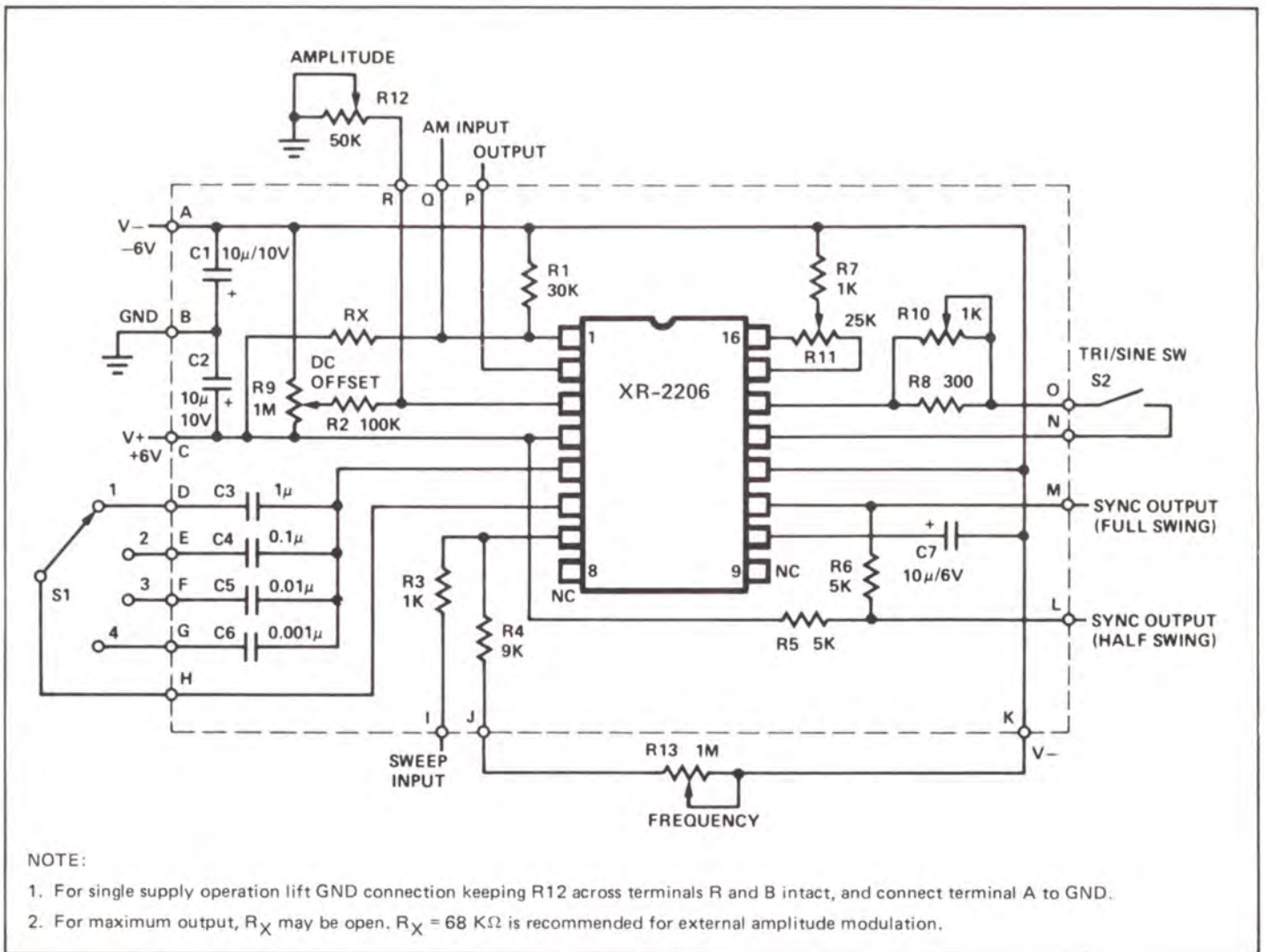

Figure 1. Circuit Connection Diagram for Function Generator. (See Note 1 for single supply operation.)

(h) **Amplitude Modulation (AM):** The output amplitude varies linearly with modulation voltage applied to AM input (terminal Q of Figure 1). The output amplitude reaches its minimum as the AM control voltage approaches the half of the total power supply voltage. The phase of the output signal reverses as the amplitude goes through its minimum value. The total dynamic range is approximately 55 dB, with AM control voltage range of 4V referenced to the half of the total supply voltage. When not used, AM terminal should be left open circuited.

(i) **Power Source:** Split supplies: ±6V, or single supply: +12V. Supply Current: 15 mA (see Figure 3).

EXPLANATION OF CIRCUIT CONTROLS:

Switches

Range Select Switch, S1: Selects the frequency range of operation for the function generator. The frequency is inversely proportional to the timing capacitor connected across Pins 5 and 6 of the XR-2206 circuit. Nominal capacitance values and frequency ranges corresponding to switch positions of S1 are as follows:

Position	Nominal Range	Timing Capacitance
1	1 Hz to 100 Hz	1 μF
2	10 Hz to 1 kHz	0.1 μF
3	100 Hz to 10 kHz	0.01 μF
4	1 kHz to 100 kHz	0.001 μF

If additional frequency ranges are needed, they can be added by introducing additional switch positions.

Triangle/Sine Waveform Switch, S2: Selects the triangle or sine output waveform.

Trimmers and Potentiometers

DC Offset Adjustment, R9: The potentiometer used for adjusting the DC offset level of the triangle or sine output waveform.

Sinewave Distortion Adjustment, R10: Adjusted to minimize the harmonic content of sinewave output.

Sinewave Symmetry Adjustment, R11: Adjusted to optimize the symmetry of the sinewave output.

Amplitude Control, R12: Sets the amplitude of the triangle or sinewave output.

Frequency Adjust, R13: Sets the oscillator frequency for any range setting of S1. Thus, R13 serves as a frequency dial on a conventional waveform generator and varies the frequency of the oscillator over an approximate 100 to 1 range.

Terminals

- A. Negative Supply $-6V$
- B. Ground
- C. Positive Supply $+6V$
- D. Range 1, timing capacitor terminal
- E. Range 2, timing capacitor terminal
- F. Range 3, timing capacitor terminal
- G. Range 4, timing capacitor terminal
- H. Timing capacitor common terminal
- I. Sweep Input
- J. Frequency adjust potentiometer terminal
- K. Frequency adjust potentiometer negative supply terminal
- L. Sync output (1/2 swing)
- M. Sync output (full swing)
- N. Triangle/sine waveform switch terminals
- O. Triangle/sine waveform switch terminals
- P. Triangle or sinewave output
- Q. AM input
- R. Amplitude control terminal

PARTS LIST

The following is a list of external circuit components necessary to provide the circuit interconnections shown in Figure 1.

Capacitors:

- C1, C2, C7 Electrolytic, $10 \mu F$, 10V
- C3 Mylar, $1 \mu F$, nonpolar, 10%
- C4 Mylar, $0.1 \mu F$, 10%
- C5 Mylar, $0.01 \mu F$, 10%
- C6 Mylar, 1000 pF, 10%

Resistors:

- R1 $30 K\Omega$, 1/4W, 10%
- R2 $100 K\Omega$, 1/4W, 10%
- R3, R7 $1 K\Omega$, 1/4W, 10%
- R4 $9 K\Omega$, 1/4W, 10%
- R5, R6 $5 K\Omega$, 1/4W, 10%
- R8 300Ω , 1/4W, 10%
- RX $62 K\Omega$, 1/4 W, 10% (RX can be eliminated for maximum output)

Potentiometers:

- R9 Trim, $1 M\Omega$, 1/4W
- R10 Trim, $1 K\Omega$, 1/4W
- R11 Trim, $25 K\Omega$, 1/4W

The following additional items are recommended to convert the circuit of Figure 1 to a complete laboratory instrument:

Potentiometers:

- R12 Amplitude control, linear, $50 K\Omega$
- R13 Frequency control, audio taper, $1 M\Omega$

Switches:

- S1 Rotary switch, 1-pole, 4 pos.
- S2 Toggle or slide, SPST

Case:

7" x 4" x 4" (approx.) Metal or Plastic
(See Figures 4(a) and 4(b).)

Power Supply:

Dual supplies $\pm 6V$ or single $+12V$
Batteries or power supply unit
(See Figures 3(a) and 3(b).)

Miscellaneous:

Knobs, solder, wires, terminals, etc.

BOARD LAYOUT

Figures 2(a) and 2(b) show the recommended printed-circuit board layout for the function generator circuit of Figure 1.

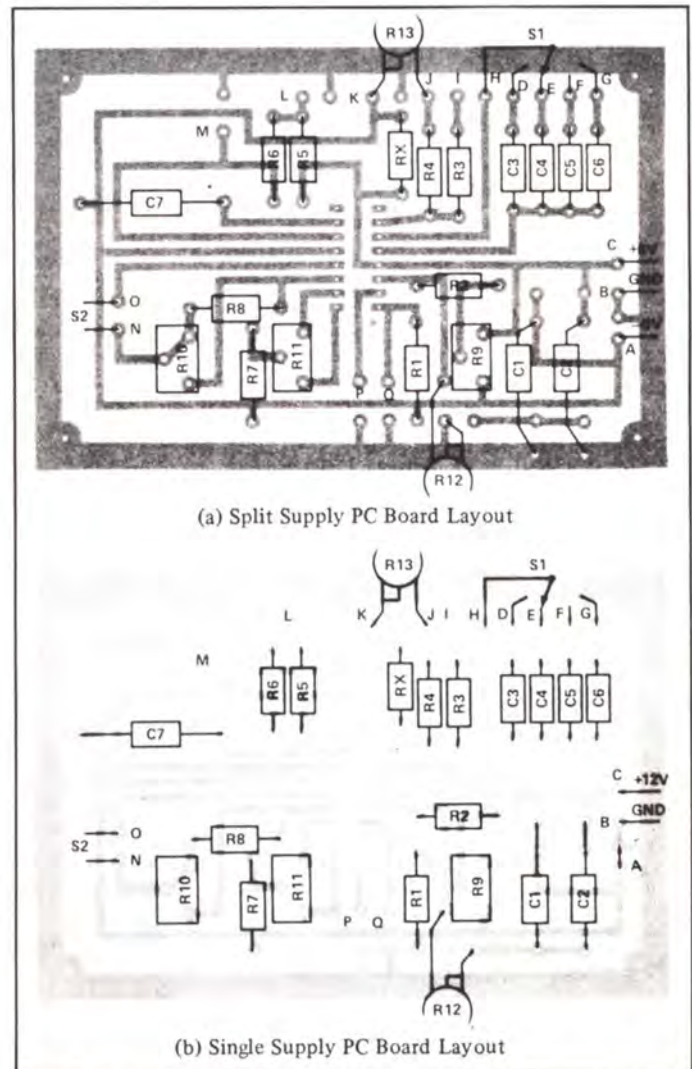

Figure 2. Recommended PC Board Layout for Function Generator Circuit of Figure 1.

RECOMMENDED ASSEMBLY PROCEDURE

The following instructions and recommendations for the assembly of the function generator assume that the basic PC board layout of Figures 2(a) or 2(b) is used in the circuit assembly.

All the parts of the generator, with the exception of frequency adjust potentiometer, amplitude control potentiometer, triangle/sine switch and frequency range select switch, are mounted on the circuit board.

Install and solder all resistors, capacitors and trimmer resistors on the PC board first. Be sure to observe the polarity of capacitors C1, C2 and C7. The timing capacitors C3, C4, C5 and C6 must be non-polar type. Now install IC1 on the board. We recommend the use of an IC socket to prevent possible damage to the IC during soldering and to provide for easy replacement in case of a malfunction.

The entire generator board along with power supply or batteries and several switches and potentiometers will fit into a case of the type readily available at electronic hobby shops. It will be necessary to obtain either output jacks or terminals for the outputs and AM and frequency sweep inputs.

Install the frequency adjust pot, the frequency range select switch, the output amplitude control pot, the power switch, and the triangle/sine switch on the case. Next, install the PC board in the case, along with a power supply.

Any simple power supply having reasonable regulation may be used. Figure 3 gives some recommended power supply configuration.

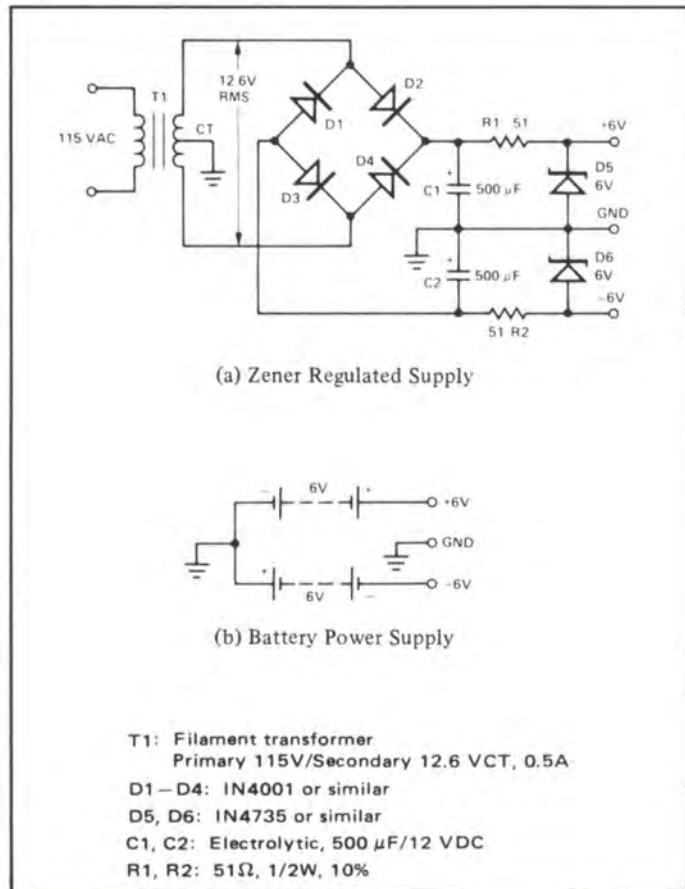

Figure 3. Recommended Power Supply Configurations.

Precaution: Keep the lead lengths small for the range selector switch.

Figure 4 gives an example of the fully assembled version of the function generator system described above.

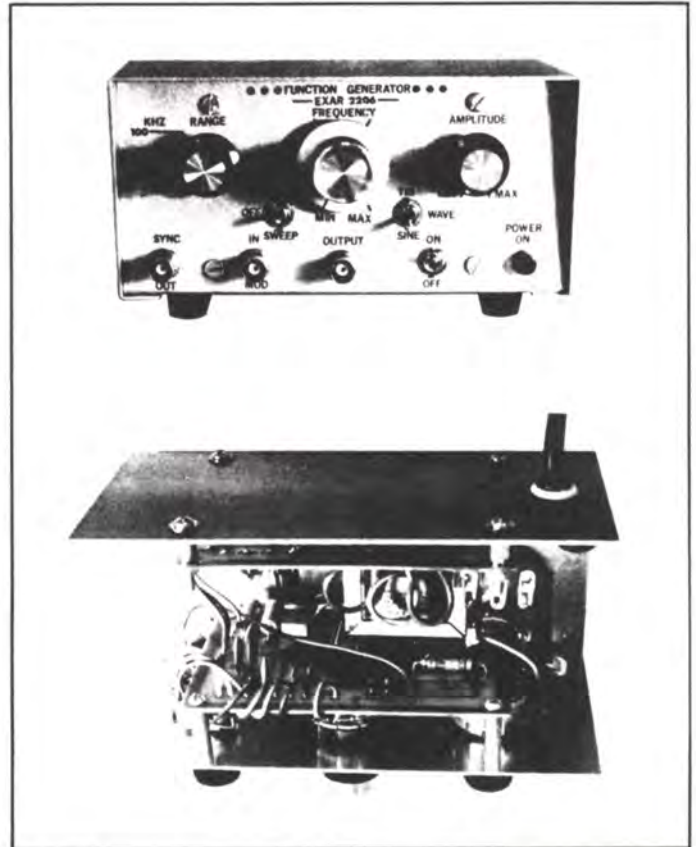

Figure 4. Typical Example of a Fully Assembled Function Generator.

ADJUSTMENT PROCEDURE

When assembly is completed and you are ready to put the function generator into operation, make sure that the polarity of power supply and the orientation of the IC unit are correct. Then apply the DC power to the unit.

To adjust for minimum distortion, connect the scope probe to the triangle/sine output. Close S2 and adjust the amplitude control to give non-clipping maximum swing. Then adjust R10 and R11 alternately for minimum distortion by observing the sinusoidal waveform. If a distortion meter is available, you may use it as a final check on the setting of sine-shaping trimmers. The minimum distortion obtained in this manner is typically less than 1% from 1 Hz to 10 kHz and less than 3% over the entire frequency range.

An Electronic Music Synthesizer Using the XR-2207 and the XR-2240

INTRODUCTION

This application note describes a simple, low-cost "music synthesizer" system made up of two monolithic IC's and a minimum number of external components. The electronic music synthesizer is comprised of the XR-2207 programmable tone generator IC which is driven by the pseudo-random binary pulse pattern generated by the XR-2240 monolithic counter/timer circuit.

PRINCIPLE OF OPERATION

All the active components necessary for the electronic music synthesizer system is contained in the two low-cost monolithic IC's, the XR-2207 variable frequency oscillator and the XR-2240 programmable counter/timer. Figure 1 shows the functional block diagram of the XR-2207 oscillator. This monolithic IC is comprised of four functional blocks: a variable-frequency oscillator which generates the basic periodic waveforms; four current switches actuated by binary keying inputs; and buffer amplifiers for both the triangle and square-wave outputs. The internal current switches transfer the oscillator current to any of four external timing resistors to produce four discrete frequencies which are selected according to the binary logic levels at the keying terminals (pins 8 and 9).

The XR-2240 programmable counter/timer is comprised of an internal time-base oscillator, a control flip-flop and a programmable 8-bit binary counter. Its functional block diagram is shown in Figure 2, in terms of the 16-pin IC package. The eight separate output terminals of the XR-2240 are "open-collector" type outputs which can either be used individually, or can be connected in a "wired-or" configuration.

Figure 3 shows the circuit connection for the electronic music or time synthesizer system using the XR-2207 and the XR-2240. The XR-2207 produces a sequence of tones by oscillating at a

frequency set by the external capacitor C_1 and the resistors R_1 through R_4 connected to Pins 4 through 7. These resistors set the frequency or the "pitch" of the output tone sequence. The counter/timer IC generates the pseudo-random pulse patterns by selectively counting down the time-base frequency. The counter outputs of XR-2240 (Pins 1 through 8) then activate the timing resistors R_1 through R_4 of the oscillator IC, which converts the binary pulse patterns to tones. The time-base oscillator frequency of the counter/timer sets the "beat" or the tempo of the music. This setting is done through C_3 and R_0 of Figure 3.

The pulse sequence coming out of the counter/timer IC can be programmed by the choice of counter outputs (Pins 1 through 8 of XR-2240 connected to the programming pins (Pins 4 through 7) of the XR-2207 VCO. The connection of Figure 3 is recommended since it gives a particularly melodic tone sequence at the output.

The pseudo-random pulse pattern out of the counter-timer repeats itself at 8-bit (or 256 count) intervals of the time-base period. Thus, the output tone sequence continues for about 1 to 2 minutes (depending on the "beat") and then repeats itself. The counter/timer resets to zero when the device is turned on; thus, the music, or the tone sequence, always starts from the same point when the synthesizer is turned on.

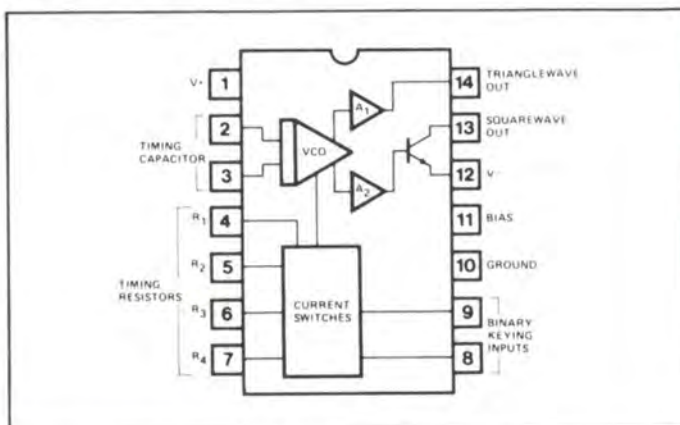

Figure 1. Functional Block Diagram of XR-2207 Oscillator Circuit.

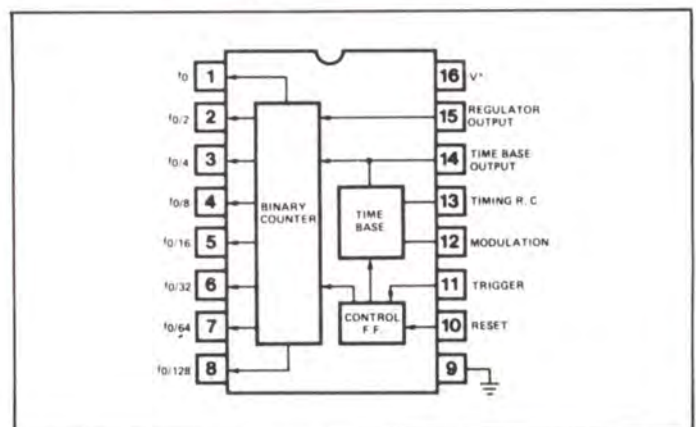

Figure 2. Functional Block Diagram of XR-2240 Counter/Timer.

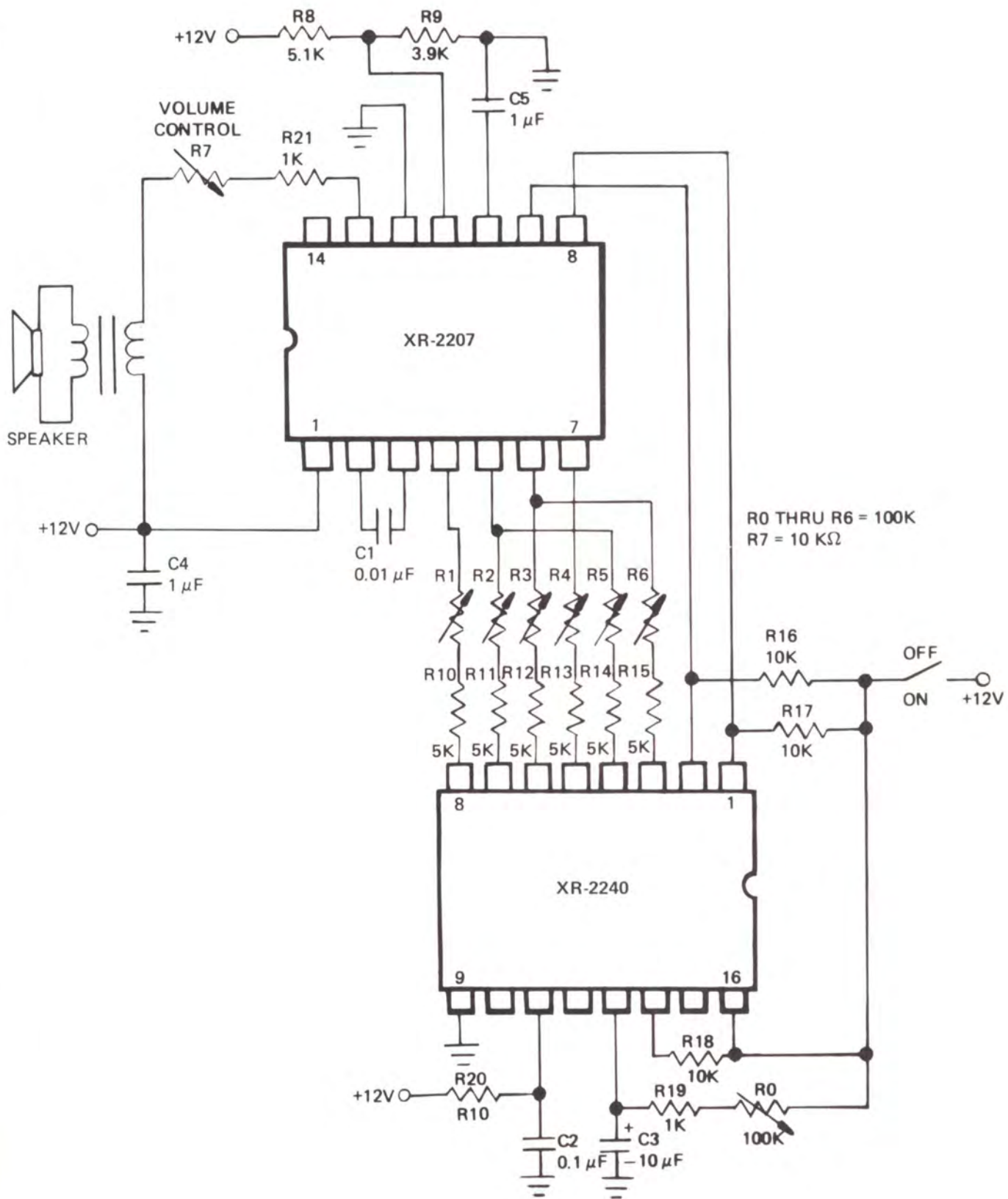

Figure 3. Circuit Connection Diagram for the Music Synthesizer.

Monolithic Chips for Hybrid Assemblies

The major performance characteristics of Exar products are also available in chip form. All chips are 100% electrically tested for guaranteed DC parameters at 25°C; and 100% visually inspected at 30x to 100x magnification using Exar's standard visual inspection criteria or MIL-STD-883, Method 201, depending on the individual customer requirements. Each chip is protected with an inert glass passivation layer over the metal interconnections. The chips are packaged in waffle-pack carriers with an anti-static shield and cushioning strip plated over the active surface to assure protection during shipment. All chips are produced on the same well-proven production lines that produce Exar's standard encapsulated devices. The Quality Assurance testing of dice is provided by normal production testing of packaged devices.

ELECTRICAL PARAMETERS

Probing the IC chips in die form limits the electrical testing to low level DC parameters at 25°C. These DC parameters are characteristic of those parameters contained on the individual device data sheet and are guaranteed to an LTPD of 10%.

The AC parameters, which are similar to those in the standard Exar device data sheets, have been correlated to selected DC probe parameters and are guaranteed to an LTPD of 20%.

HANDLING PRECAUTIONS AND PACKAGING OPTIONS

Extreme care must be used in the handling of unencapsulated semiconductor chips or dice to avoid damage to the chip surface. Exar offers the following three handling or packaging options for monolithic chips supplied to the customer:

Cavity or Waffle Pack: The dice are placed in individual compartments of the waffle pack (see figure). The plastic snap clips permit inspection and resealing.

Vial Pack: The vial is filled with inert freon TF and a plastic cap seals the vial. The freon acts as a motion retarder and cleansing agent.

Wafer Pack: The entire wafer is sandwiched between two pieces of mylar and vacuum sealed in a plastic envelope.

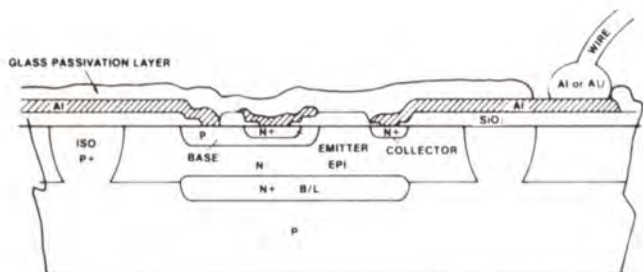

Typical Bipolar Chip Cross Section

FEATURES

- DC Parameters Guaranteed at 25°C
- 100% Visual Inspection
- Care in Packaging
- 100% Stabilization Bake (Wafer Form)
- 10% LTPD on DC Electrical Parameters

CHIPS IN WAFER FORM

Probed and inked wafers are also available from Exar. The hybrid microcircuit designer can specify either scribed or unscribed wafers and receive a fully tested silicon wafer. Rejected die are clearly marked with an ink dot for easy identification in wafer form.

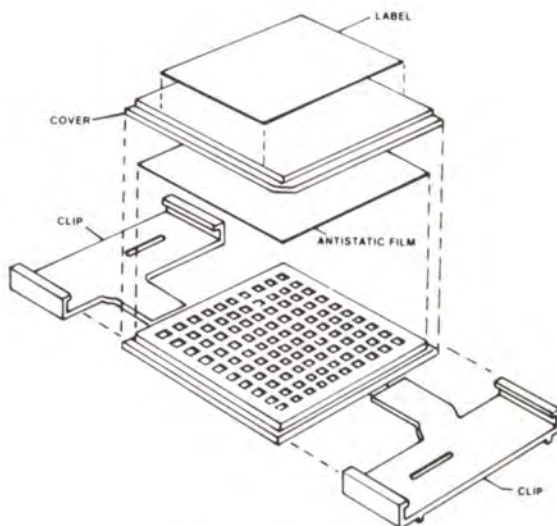

Typical Cavity Pack
(Waffle Pack)

XR-205 MONOLITHIC WAVEFORM GENERATOR

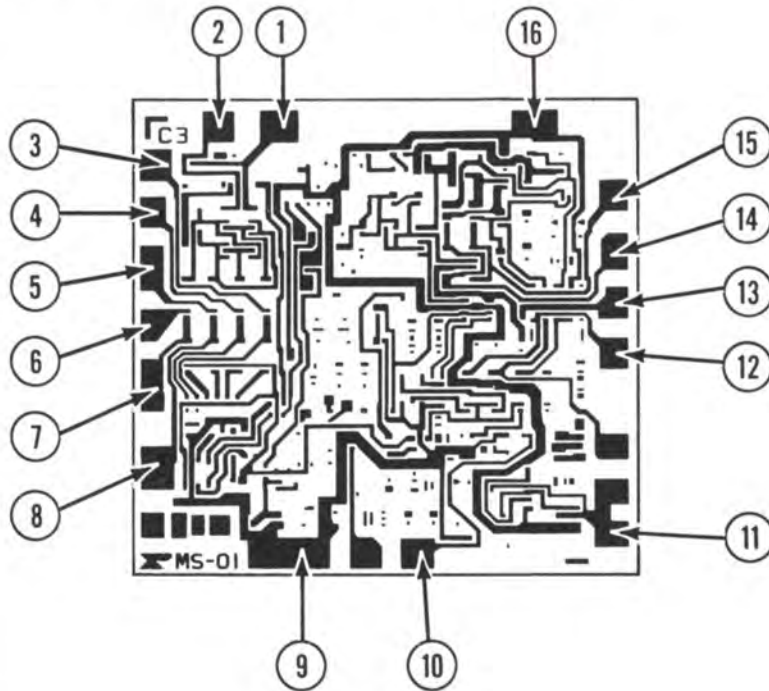

Pad No.	Pad Function
1	Modulator Output
2	Modulator Output
3	Modulator X-Input
4	Modulator X-Input
5	Modulator Y-Input
6	Modulator Y-Input
7	Waveform Adj.
8	Waveform Adj.
9	-VEE
10	Buffer Input
11	Buffer Output
12	Square Wave Output
13	FM/Sweep Input
14	Timing Capacitor
15	Timing Capacitor
16	+VCC

Chip Size: 76 mils x 78 mils
(1.93 mm x 1.98 mm)

XR-2206 MONOLITHIC FUNCTION GENERATOR

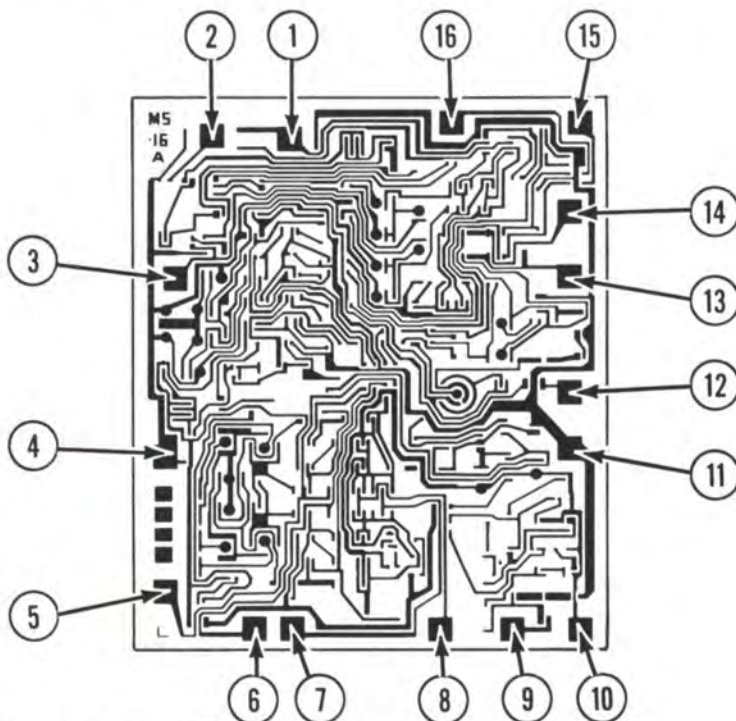

Pad No.	Pad Function
1	Amplitude Modulation
2	Sine or Triangle Output
3	Multiplier Output
4	+VCC
5	Timing Capacitor
6	Timing Capacitor
7	Timing Resistor R ₁
8	Timing Resistor R ₂
9	FSK Input
10	Bypass
11	Sync. Output
12	Ground
13	Waveform Adj.
14	Waveform Adj.
15	Symmetry Adj.
16	Symmetry Adj.

Chip Size: 88 x 105 mils
(2.23 mm x 2.66 mm)

XR-2207 VOLTAGE CONTROLLED OSCILLATOR

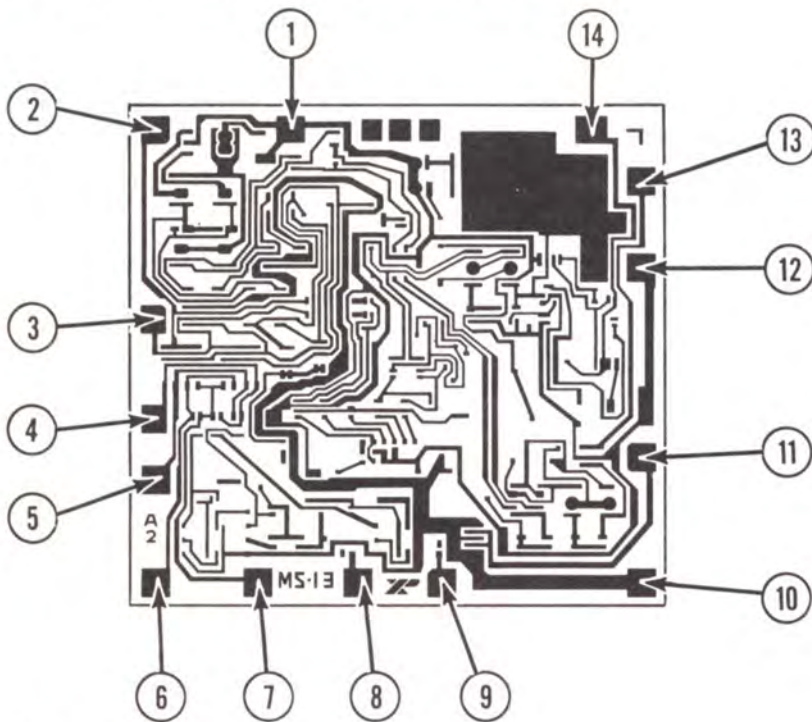

Pad No.	Pad Function
1	+VCC
2	Timing Capacitor
3	Timing Capacitor
4	Timing Resistor R ₁
5	Timing Resistor R ₂
6	Timing Resistor R ₃
7	Timing Resistor R ₄
8	Binary Keying Input
9	Binary Keying Input
10	Ground
11	Bias
12	-VEE
13	Square Wave Output
14	Triangle Wave Output

Chip Size: 80 x 85 mils.
(2.03 mm x 2.16 mm)

XR-2209 PRECISION OSCILLATOR

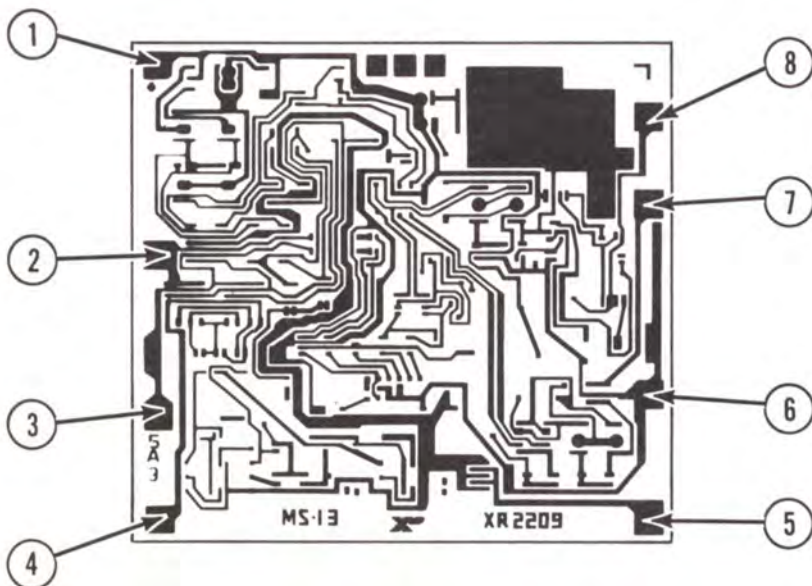

Pad No.	Pad Function
1	+VCC
2	Timing Capacitor
3	Timing Capacitor
4	Timing Resistor
5	Bias
6	-VEE
7	Square Wave Output
8	Triangle Wave Output

Chip Size: 80 x 85 mils
(2.03 mm x 2.16 mm)

XR-8038 PRECISION WAVEFORM GENERATOR

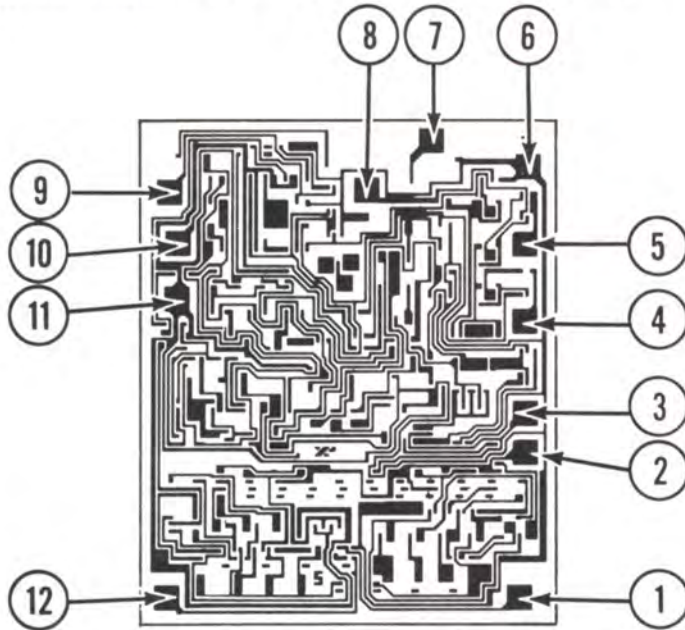

Pad No.	Pad Function
1	Distortion Adj.
2	Sine Wave Output
3	Triangle Wave Output
4	Duty-Cycle Adj.
5	Duty-Cycle Adj.
6	+VCC
7	FM Bias
8	FM/Sweep Input
9	Square Wave Output
10	Timing Capacitor
11	Ground
12	Distortion Adj.

Chip Size: 75 x 92 mils.
(1.82 mm x 2.33 mm)

Product Ordering Information

PART IDENTIFICATION:

XR — **XXXXX**
 Manufacturer's Prefix Basic Type (5 spaces)

Grade	Package Type
M = Military	N = Ceramic Dual-in-line
N = Prime	P = Plastic Dual-in-line
Electrical	T = Metal can
P = Prime	D = Chip (Dice)
Electrical	A = } Kit variations
C = Commercial	B = }
K = Kit	W = Wafer

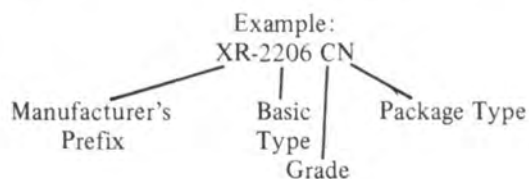

Definition of Symbols:

M = Military Grade Part, Ceramic Package Only. All Military Grades have been processed to MIL-STD-883 Level C, and are guaranteed to operate over military temperature range.

N = Prime Grade Part, Ceramic Package.

P = Prime Grade Part, Plastic Package.

CN = Commercial Grade Part, Ceramic Package.

CP = Commercial Grade Part, Plastic Package.

N, P, CN and CP parts are electrically identical and guaranteed to operate over 0°C to +75°C range unless otherwise stated. In addition, N and P parts generally have operating parameters more tightly controlled than the CN or CP parts.

For details, consult Exar Sales Headquarters or Sales/Technical Representatives.

FOREIGN SALES OFFICES AND REPRESENTATIVES

ARGENTINA

Rayo Electronics SRL
Belgrando 990
Pisos 6Y2
Phone: 37 98 90
Telex: (390) 122153 (RAYOX AR)

AUSTRALIA

A. J. Ferguson (Adelaide) Pty. Ltd.
44 Prospect Road
Prospect, S.A. 5082
Phone 26 91 244
Telex (790) 82635 (FERGAD)

BELGIUM

(See Germany)

BRASIL

R.Ohm Do Brasil Industria Electronica Ltda.
Avenida Don Petro
I, 420, 01552 Sao Paulo
Telex: (391) 1121178 (UIEL BR)

DENMARK

Mer-el A/S
I, Scherfigsvej
DK-2100 Copenhagen 0
Phone: (01) 20 744 44
Telex: (855) 27260 (MEREL DK)

FINLAND

S W Instruments
Karstulantie 4
SF-00550 Helsinki 55
Phone: 83 82 65/76 24 86
Telex: (857) 12/2411 (SWI)

FRANCE

Tekelec/Airtronic
Rue Carle Vernet
F-92310 Sevres
Phone: (1) 534 75 35
Telex: (842) 204552 (TKLEC A)

GERMANY (WEST)

R.Ohm Electronics GmbH
D-4051 Korschenbroich
Muehlenstrasse 70
Phone: (02161) 29 805
Telex: (841) 852330 (ROHM D)

GREECE

General Electronics Ltd.
209 Thevon Street
Nikaia 77, Piraeus
Phone: 49 13 595
Telex: (863) 212949 (GELT GR)

HONG KONG

R.Ohm Electronics (H.K.) Co., Ltd.
Rm 1027A, Ocean Centre
5, Canton Road, Tsimshatsui,
Kowloon
Phone: 3-688841/3-672307
Telex: (780) 75294 (KSAHK HX)

INDIA

Zenith Electronics
541 Panchratna
Mama Parmanand Marg
Bombay 400004
Phone: 38 42 14
Telex: (953) 11 3152 (ZINTH IN)

ISRAEL

CVS Technologies 1974 Ltd.
9 Jabolinsky
P.O.B. 946, Bnei-Brak
Phone: 25 55 06/25 92 41
Telex: (922) 341109 (SHOEL IL)

ITALY

Eledra 3S S.p.A.
Viale Elvezia, 18
20154 Milano
Phone: 34.93.041
Telex: (843) 332332 (ELEDRA I)

JAPAN

Tokyo Electron Ltd.
Panetron Division
38 FL Shinjuku Nomura Bldg.
1-26-2, Nishi-Shinjuku
Shinjuku-ku, Tokyo 160
Phone: 03-343-4411
Telex: (781) 2322240 (LABTEL J)

LIECHTENSTEIN

(See Switzerland)

LUXEMBOURG

(See Germany)

NETHERLANDS

Tekelec/Airtronic B. V.
Stork Staat 7
2722 NN Zoetermeer
Phone: 079-310100
Telex: (844) 33332 (TKLEC NL)

NEW ZEALAND

Professional Electronics Ltd.
126 Kitchener Road
Milford, Auckland 9
Phone: 46 94 50
Telex: (791) 21084 (PROTON)

NORWAY

Hefro Teknisk A/S
Trondheimsveier 80
Oslo 5
Phone: 38 02 86
Telex: (856) 16205 (HEFRO N)

SINGAPORE

R.Ohm Electronics Co. Pte. Ltd.
Unit G, Third Floor
Cheng Chwee Huat Ind. Bldg.
118-D, Paya Lebar Road
Singapore 1440
Phone: 2834327
Telex: (786) 26648 (ROHM S)

SOUTH AFRICA

South Continental Devices (Pty.) Ltd.
Suite 516, 5th Floor, Randover House
Cor. Hendrik Verwoerd, Dover Road
Randburg, Transvaal
Phone: 48 05 15
Telex: (960) 8-3324 (SA)

SPAIN

Elico Fastronix S. A.
Constancia 43
Madrid 2
Phone: 415 66 54
Telex: (831) 23606 (ELICO E)

SWEDEN

Lagercrantz Electronix AB
Kanalvagen 5
S-194 01 Upplands Vasby
Phone: (0760) 86 120
Telex: (854) 11275 (LAGER S)

SWITZERLAND

Amera Electronics AG
Lerchenhaldenstrasse 73
CH-8046 Zurich
Phone: (01) 57 11 12
Telex: (845) 59837 (AMERA CH)

TAIWAN

(See Hong Kong)

UNITED KINGDOM

Memec Ltd.
Thame Park Ind. Estate
Thame, Oxon OX9 3RS
Phone: (084 421) 3146
Telex: (851) 837508 (MEMEC G)

LATIN AMERICA

Intectra
2349 Charleston Road
Mt. View, CA 94043 U.S.A.
Phone: (415) 967-8818
Telex: 345545 (INTECTRA MNTV)

ALL OTHER COUNTRIES

(Call Exar Direct)

AUTHORIZED STOCKING DISTRIBUTORS

ALABAMA Resisticap, Inc. Huntsville (205) 881-9270	ILLINOIS Diplomat Electronics, Inc. Bensenville (312) 595-1000	MICHIGAN (Continued) Diplomat Electronics, Inc. Farmington (313) 477-3200	NORTH CAROLINA (See Maryland)	VERMONT (See New Hampshire)
ARIZONA Sterling Electronics Phoenix (602) 258-4531	R. M. Electronics Westmont (312) 323-9670	R. M. Electronics Grand Rapids (616) 531-9300	NORTH DAKOTA (Call Exar Direct)	VIRGINIA (See Maryland)
ARKANSAS (See Oklahoma)	INDIANA Graham Electronics Indianapolis (317) 634-8202	MINNESOTA Diplomat Electronics, Inc. Minneapolis (612) 788-8601	OHIO Graham Electronics Cincinnati (513) 772-1661	WASHINGTON Radar Electric Co., Inc. Seattle (206) 282-2511
CALIFORNIA Diplomat Electronics, Inc. Sunnyvale (408) 734-1900	R. M. Electronics Indianapolis (317) 247-9701	MISSISSIPPI (See Alabama)	OKLAHOMA Component Specialties, Inc. Tulsa (918) 664-2820	Sterling Electronics Seattle (206) 575-1910
Intermark Electronics San Diego (714) 279-5200	IOWA DEECO, Incorporated Cedar Rapids (319) 365-7551	MISSOURI Diplomat Electronics St. Louis (314) 645-8550	Radio, Inc. Tulsa (918) 587-9123	WISCONSIN Taylor Electric Company Mequon (414) 241-4321
Intermark Electronics Santa Ana (714) 540-1322	Iowa Technical Supply Cedar Rapids (319) 377-5795	Olive Industrial Electronics St. Louis (314) 426-4500	OREGON Radar Electric Co., Inc. Portland (503) 233-3691	WYOMING (See Colorado)
Intermark Electronics Sunnyvale (408) 738-1111	KANSAS Radio Supply Wichita (316) 267-5216	MONTANA (Call Exar Direct)	PENNSYLVANIA Advacom Erie (814) 476-7774	CANADA Future Electronics Montreal, Quebec (514) 731-7441
JACO Chatsworth (213) 998-2200	KENTUCKY (See Indiana)	NEVADA (See California)	Pioneer Electronics Horsham (215) 674-4000	Intek Electronics Ltd. Vancouver, B.C. (604) 324-6831
Western Micro Technology Cupertino (408) 725-1660	LOUISIANA (See Texas)	NEW HAMPSHIRE Yankee Electric Supply Manchester (603) 625-9746	RHODE ISLAND (See Massachusetts)	R-A-E Industrial Elect. Ltd. Burnaby, B.C. (604) 291-8866
COLORADO Bell Industries Wheatridge (303) 424-1985	MAINE (See New Hampshire)	NEW JERSEY Diplomat Electronics, Inc. Mount Laurel (609) 234-8080	SOUTH CAROLINA (See Maryland)	PAAR Ind. Electronics Ltd. Calgary, Alberta (403) 287-2841
Diplomat Electronics, Inc. Denver (303) 427-5544	MARYLAND Diplomat Electronics, Inc. Columbia (301) 995-1226	Diplomat Electronics, Inc. Totowa (201) 785-1830	SOUTH DAKOTA (Call Exar Direct)	PAAR Ind. Electronics Ltd. Edmonton, Alberta (403) 436-4445
CONNECTICUT (See Massachusetts)	Pioneer Electronics Gaithersburg (301) 948-0710	NEW MEXICO Bell Industries Albuquerque (505) 292-2700	TENNESSEE (See Alabama)	W. E. S. Limited Winnipeg, Manitoba (204) 632-1260
DELAWARE (See Pennsylvania)	MASSACHUSETTS Diplomat Electronics, Inc. Holliston (617) 429-4121	NEW YORK Components Plus Hauppauge (516) 231-9200	TEXAS Component Specialties, Inc. Austin (512) 837-8922	Cam Gard Supply Ltd. Calgary, Alberta (403) 287-0520
FLORIDA Diplomat Southland Clearwater (813) 443-4514	Gerber Electronics Dedham (617) 329-2400	Diplomat Electronics, Inc. Woodbury (516) 921-9373	Component Specialties, Inc. Dallas (214) 357-6511	Cam Gard Supply Ltd. Saskatoon, Saskatchewan (306) 652-6424
Diplomat Southland Ft. Lauderdale (305) 971-7160	RC Components Wilmington (617) 657-4310	Diplomat Electronics, Inc. Syracuse (315) 437-9900	Component Specialties, Inc. Houston (713) 771-7237	Cam Gard Supply Ltd. Toronto, Ontario (416) 252-5031
Diplomat Southland Palm Bay (305) 725-4520	MICHIGAN Camelot Electronics, Inc. Livonia (313) 591-0050	JACO Hauppauge (516) 273-5500	UTAH Bell Industries Salt Lake City (801) 972-6969	Cam Gard Supply Ltd. Vancouver, B. C. (604) 291-1441
GEORGIA (See Florida)		Zeus Components, Inc. Elmsford (914) 592-4120	Diplomat Electronics, Inc. Salt Lake City (801) 486-4134	Cam Gard Supply Ltd. Winnipeg, Manitoba (204) 786-8401
IDAHO (See Washington)				

AUTHORIZED REPRESENTATIVES

ALABAMA Rep, Incorporated 11527 S. Memorial Pkwy. Huntsville, AL 35803 (205) 881-9270 TWX 810-726-2102	GEORGIA Rep, Incorporated 1944 Cooledge Road Tucker, GA 30084 (404) 938-4358	MINNESOTA Dan'l Engineering 12350 W. 175th St. Lakeville, MN 55044 (612) 435-6000	NEW YORK (CITY) ERA, Incorporated 1 Dupont Street Plainview, NY 11803 (516) 349-1190 TWX 510-221-1849	TEXAS Technical Marketing, Inc. 3320 Wiley Post Road Carrollton, TX 75006 (214) 387-3601 TWX 910-860-5158
ALASKA (Call Exar Direct)	HAWAII (Call Exar Direct)	MISSISSIPPI (See Alabama)	NORTH CAROLINA Component Sales, Inc. P.O. Box 18821 Raleigh, NC 27619 (919) 782-8433 TWX 510-928-0513	Technical Marketing, Inc. 6430 Hillcroft, Suite 104 Houston, TX 77081 (713) 777-9228
ARIZONA Summit Sales 7336 E. Shoeman Lane Suite 116E Scottsdale, AZ 85251 (602) 994-4587 TWX 910-950-1283	IDAHO (See Washington)	MISSOURI Dy-Tronix, Inc. 11190 Natural Bridge Bridgeton, MO 63044 (314) 731-5799 TWX 910-762-0651	NORTH DAKOTA (See Minnesota)	UTAH SK Component Sales, Inc. 2520 S. State Salt Lake City, UT 84115 (801) 484-4222
ARKANSAS (See Oklahoma)	ILLINOIS (NORTH) Janus, Incorporated 3166 Des Plaines Ave. Suite 14 Des Plaines, IL 60018 (312) 298-9330	Dy-Tronix, Inc. 13700 E. 42nd Terrace Suite 202 Independence, MO 64055 (816) 373-6600	OHIO McFadden Sales 4645 Executive Drive Columbus, OH 43220 (614) 459-1280 TWX 810-482-1623	VERMONT (See Massachusetts)
CALIFORNIA (NORTH) Trident Associates, Inc. 556 Weddell Dr., Suite 9 Sunnyvale, CA 94086 (408) 734-5900 TWX 910-339-9352	ILLINOIS (SOUTH) (See Missouri)	MONTANA (See Colorado)	OKLAHOMA Technical Marketing, Inc. 9717 East 42nd St. Suite 210 Tulsa, OK 74145 (918) 622-5984	VIRGINIA (See Maryland)
CALIFORNIA (SOUTH) Varigon Associates 137 Eucalyptus Drive El Segundo, CA 90245 (213) 322-1120 TWX 910-348-7141	INDIANA (See Ohio)	NEBRASKA (See Missouri)	NEW HAMPSHIRE (See Massachusetts)	WASHINGTON SD-R ² Products & Sales 14042 NE 8th Street Bellevue, WA 98007 (206) 747-9424 TWX 910-443-2483
Varigon/ARC 2356 Moore St., Suite 102 San Diego, CA 92110 (714) 299-5413	IOWA Dytronix, Inc. 23 Twixt Town Road, NE Suite 201 Cedar Rapids, IO 52402 (319) 377-8275	NEVADA (See California North)	OREGON (See Washington)	WASHINGTON, D.C. (See Maryland)
COLORADO SK Component Sales, Inc. 5925 E. Evans Avenue Suite 204B Denver, CO 80222 (303) 759-1666 TWX 910-931-2644	KANSAS (See Missouri)	NEW MEXICO Tri-Tronix 2403 San Mateo Blvd., NE Suite 2, South Bldg. Albuquerque, NM 87110 (505) 265-8409 TWX 910-989-1680	PENNSYLVANIA (WEST) (See Ohio)	WEST VIRGINIA (See Ohio)
CONNECTICUT Phoenix Sales 389 Main Street Ridgefield, CT 06877 (203) 438-9644 TWX 710-467-0662	KENTUCKY (See Ohio)	NEW HAMPSHIRE (See Massachusetts)	PENNSYLVANIA (EAST) Knowles Assoc., Inc. 1 Fairway Plaza, Suite 311 Huntington Vly., PA 19006 (215) 947-5641 TWX 510-665-5303	WISCONSIN (S. EAST) (See Illinois)
DELEWARE (See Maryland)	LOUISIANA (See Texas)	NEW JERSEY (NORTH) (See New York City)	RHODE ISLAND (See Massachusetts)	WISCONSIN (WEST) (See Minnesota)
FLORIDA EIR, Incorporated 450 Seminola Blvd. Casselberry, FL 32707 (305) 830-9600 TWX 810-853-9213	MAINE (See Massachusetts)	NEW JERSEY (SOUTH) (See Pennsylvania)	SOUTH CAROLINA (See North Carolina)	WYOMING (See Colorado)
MASSACHUSETTS Contact Sales, Inc. 101 Cambridge Street Burlington, MA 01803 (617) 273-1520 TWX 710-332-6569	MARYLAND Component Sales, Inc. 3701 Old Court Rd. Suite 14 Baltimore, MD 21208 (301) 484-3647 TWX 710-862-0852	NEW YORK (UPSTATE) Quality Components, Inc. 2095 Kensington Avenue Buffalo, NY 14226 (716) 839-4170	SOUTH DAKOTA (See Minnesota)	CANADA (EAST) R.F.Q. Limited 385 The West Mall Suite 209 Etobicoke, Ontario M9C 1E7 (416) 626-1445 TWX 610-492-2540
MICHIGAN (See Ohio)	NEW YORK (CITY) Quality Components, Inc. 116 E. Fayette St. Manlius, NY 13104 (315) 682-8885 TWX 710-545-0663	TENNESSEE Rep, Incorporated 113 S. Branner Ave. Jefferson City, TN 37760 (615) 475-4105 TWX 810-570-4203	TEXAS R.F.Q. Limited P.O. Box 213 Dollard Des Ormeaux Montreal, Quebec H9G 2H8 (514) 694-5724 TLX 05-821762	



EXAR INTEGRATED SYSTEMS, INC., P.O. Box 62229, Sunnyvale, California 94088 • Phone (408) 732-7970

If You Didn't Get This From My Site,
Then It Was Stolen From...

www.SteamPoweredRadio.Com