

# SST-30 FM EXCITER MANUAL

MANUFACTURED BY:

ENERGY-ONIX BROADCAST EQUIPMENT CO., INC.  
1306 RIVER STREET  
VALATIE, NEW YORK 12184



NOVEMBER 1996

## SST-30 FM EXCITER TABLE OF CONTENTS

	<u>PAGE</u>
INTRODUCTION.....	2
TECHNICAL SPECIFICATIONS.....	3 - 5
INSTALLATION.....	6
INSPECTION.....	6
AC POWER.....	6
PRELIMINARY TESTING.....	6
REAR PANEL CONNECTIONS.....	6
MODULATION INPUT SIGNALS.....	7
MONITOR AND CONTROL SIGNALS.....	7
EXTERNAL REFERENCE.....	7
ADJUSTMENTS.....	7
MAINTENANCE.....	7
FUSES.....	8
INTEGRATED CIRCUITS.....	8
RF AND POWER TRANSISTORS.....	8
SMALL COMPONENTS.....	8 - 9
ALIGNMENT.....	9
POWER SUPPLY.....	9
AUDIO MULTIPLEX AND SCA.....	9
VSWR METER.....	9
PARTS LIST.....	10 - 16
POWER SUPPLY SCHEMATICS #S-222, #S-223, #S-216.....	17 - 19
AUDIO INPUT SCHEMATIC #S-217.....	20
MAIN BOARD SCHEMATIC:	
VCO & RF DRIVE.....SCHEMATIC S-224.....	21
AUDIO SECTION.....SCHEMATIC S-225.....	22
FREQUENCY DIVIDER SECTION.....SCHEMATIC S-281.....	23
POWER AMPLIFIER.....SCHEMATIC S-218, S-219.....	24 - 25
AUDIO INPUT.....SCHEMATIC S-217.....	26
RECOMMENDED SPARE PARTS.....	27
MAIN BOARD COMPONENT LAYOUT.....SCHEMATIC S-220.....	28

## INTRODUCTION

THE SST-30 EXCITER IS THE LATEST IN STATE OF THE ART PRODUCTS AVAILABLE FROM ENERGY-ONIX. THIS EXCITER IS DESIGNED WITH HIGH RELIABILITY COMPONENTS AND IS INTENDED TO GIVE YEARS OF TROUBLE FREE CONTINUOUS DUTY OPERATION. THE UNIT INCORPORATES MANY NEW FEATURES INCLUDING AUTOMATIC RF LEVEL CONTROL AND MONITORING OF THE EXCITER PARAMETERS.

THE FOLLOWING PAGES IN THIS MANUAL WILL DESCRIBE THE INSTALLATION AND OPERATION. PARTS LISTS AND SCHEMATIC DIAGRAMS HAVE BEEN SUPPLIED FOR MAINTENANCE OF THE UNIT.

## TECHNICAL SPECIFICATION SST-30

<b>RATED OUTPUT POWER:</b>	<b>2 - 30W CONTINUOUSLY VARIABLE (A.L.C.)</b>
<b>R.F. OUTPUT CONNECTOR:</b>	<b>"N" TYPE</b>
<b>R.F. OUTPUT IMPEDANCE:</b>	<b>50 OHM</b>
<b>FREQUENCY RANGE:</b>	<b>87.5 MHz TO 108 MHz</b>
<b>FREQUENCY PROGRAMABILITY:</b>	<b>DIRECT FROM FRONT PANEL IN 10 KHz INCREMENTS</b>
<b>FREQUENCY STABILITY:</b>	<b>BETTER THAN +/- 500 Hz</b>
<b>MODULATION TYPE:</b>	<b>DIRECT CARRIER FREQUENCY MODULATION</b>
<b>SPURIOUS &amp; HARMONIC SUPPRESSION:</b>	<b>MEETS OR EXCEEDS ALL FCC AND CCIR REQUIREMENTS</b>
<b>ASYNCHRONOUS AM S/C RATIO:</b>	<b>65dB BELOW REFERENCE CARRIER WITH 100% AMPLITUDE MODULATION AT 400 Hz WITHOUT DE-EMPHASIS, NO FM MODULATION PRESENT</b>
<b>TRANSIENT INTERMODULATION DISTORTION:</b>	<b>LESS THAN 0.1% MEASURED WITH A 3.18 KHz SQUARE WAVE AND A 15 KHz SINE WAVE AT 100% MODULATION (TYPICAL 0.05%)</b>
<b>AC POWER REQUIREMENT:</b>	<b>117 TO 230 VAC +/- 10% 50 TO 60 Hz</b>
<b>AVAILABLE TRANSFORMER TAPS:</b>	<b>100,120, 220, 240, VAC</b>
<b>POWER CONSUMPTION:</b>	<b>APROX. 130 WATTS FROM AC LINE</b>
<b>ALTERNATE DC POWER REQUIREMENT:</b>	<b>24 VDC AT 4 AMPS</b>
<b>PANEL SIZE:</b>	<b>483mm (19") W x 133mm (5.25") H x 327mm (13") D</b>
<b>WEIGHT:</b>	<b>7 KG (15.5 LBS)</b>
<b>AMBIENT TEMPERATURE RANGE:</b>	<b>0°C TO 45°C (32°F TO 113°F)</b>
<b>PRE-EMPHASIS:</b>	<b>FOR FCC 75 MICROSEC FOR CCIR 50 MICROSEC</b>
<b>COMPOSITE OPERATION:</b>	

## TECHNICAL SPECIFICATION (CONTD)

COMPOSITE INPUTS:	4 TOTAL, 1 FOR MPX ND 3 FOR SCA
MPX INPUTS:	1 UNBALANCED INPUT WITH BNC CONNECTOR
MPX INPUT IMPEDENCE:	10K OHM
MPX INPUT LEVEL:	0 dBm (775 MV RMS/2.2 V P-P) NOMINAL FOR +/- 75 KHz DEVIATION, ADJUSTABLE
COMPOSITE FM S/H RATIO:	>70 dB BELOW +/- 75 KHz DEVIATION AT 400 Hz MEASURED IN A 30 Hz TO 100 KHz BANDWIDTH WITH 75 MICROSEC DE-EMPHASIS (RMS)
COMPOSITE AMPLITUDE RESPONSE:	+/- 0.8dB, 30 Hz TO 100 KHz
COMPOSITE TOTAL HARMONIC DISTORTION:	LESS THAN 0.1% (0.05% TYPICAL)
COMPOSITE INTERMODULATION DISTORTION:	0.05% OR LESS, MEASURED WITH 1kHz AND 1.3 KHz TONES, 1:1 RATIO AT 100% MODULATION
STEREO SEPARATION:	>40 dB (45 dB TYPICAL)
CROSSTALK:	MAIN TO STEREO SUBCHANNEL AND STEREO SUBCHANNEL TO MAIN, 55 dB (60 dB TYPICAL)
SCA INPUTS: CONNECTORS	3 UNBALANCED, BNC
SCA INPUT IMPEDANCE:	10K OHM
SCA INPUT LEVELS:	0 dBm (775 MV RMS/2.2 V P-P) NOMINAL FOR +/- 7.5 KHz DEVIATION, ADJUSTABLE
SCA AMPLITUDE RESPONSE:	+/- 0.8 dB, 40 KHz TO 100 KHz
CROSSTALK:	67 KHz SCA TO MAIN OR TO STEREO SUBCHANNEL, 65 dB
MONAURAL OPERATION:	

## TECHNICAL SPECIFICATIONS (CONTD)

<b>AUDIO INPUT IMPEDANCE:</b>	<b>600 OHM BALANCE OR UNBALANCED 50 dB COMMON MODE SUPPRESSION</b>
<b>AUDIO INPUT LEVEL:</b>	<b>0 dBm (775 MV RMS/2.2 V P-P)</b>
<b>FM S/N RATIO:</b>	<b>&gt;70 dB BELOW +/- 75 KHz DEVIATION AT 400 Hz MEASURED IN A 30 Hz TO 20 KHz BANDWIDTH WITH 75 MICROSEC DE-EMPHASIS (RMS)</b>
<b>AUDIO FREQUENCY RESPONSE:</b>	<b>+/- 0.8 dB, 30 Hz TO 15 KHz</b>
<b>TOTAL HARMONIC DISTORTION:</b>	<b>LESS THAN 0.1% (0.05% TYPICAL)</b>
<b>INTERMODULATION DISTORTION:</b>	<b>0.05% OR LESS, MEASURED WITH 1 KHz AND 1.3 KHz TONES, 1:1 RATIO, AT 100% MODULATION</b>

## INSTALLATION

### INSPECTION

CAREFULLY INSPECT THE UNIT AFTER REMOVING IT FROM THE BOX. REMOVE THE FOUR SCREWS IN THE TOP PANEL AND MAKE SURE THAT ALL THE CABLES INSIDE ARE PROPERLY IN PLACE AND HAVE NOT BECOME LOOSE DURING SHIPPING.

### AC POWER

ON THE REAR PANEL OF THE EQUIPMENT, INSPECT THE POWER PLUG ASSEMBLY. THERE ARE FOUR VOLTAGES PRINTED IN THE SQUARE BLOCK ABOVE THE POWER CORD PLUG. DETERMINE THE VOLTAGE TO BE USED AND REMOVE THE SQUARE PANEL. TURN THE BLOCK SO THAT THE DESIRED OPERATING VOLTAGE LETTERING IS NEXT TO THE WHITE ARROW WHEN PLUGGING THE BLOCK BACK IN. THE WHITE ARROW IS LOCATED ON THE RIGHT SIDE OF THE BLOCK HOLDER. THIS SETS THE AC OPERATING VOLTAGE OF THE UNIT.

### PRELIMINARY TESTING

FOR TESTING PURPOSES CONNECT A SUITABLE DUMMY LOAD TO THE REAR PANEL "N" CONNECTOR. ON THE FRONT PANEL SET THE POWER SWITCH TO OFF. SET THE PWR, DEV SWITCH TO PWR. SET THE DIR, REF SWITCH TO DIR. WITH A SMALL FLAT BLADE SCREWDRIVER, SET THE PWR ADJ CONTROL TO THE FULLY COUNTER CLOCKWISE POSITION. DETERMINE THE OPERATING FREQUENCY TO BE USED AND SET THIS INTO THE DIGISWITCH ON THE FRONT PANEL. THIS DIGISWITCH IS CAPABLE OF SETTING THE FREQUENCY IN 10 KHz STEPS. RECHECK THE AC POWER INPUT VOLTAGE. PLUG THE POWER CORD INTO THE AC SUPPLY.

TURN THE POWER SWITCH TO THE ON POSITION AND CHECK THE FRONT PANEL INDICATIONS. THE AC POWER INDICATOR SHOULD COME ON. THE THREE DC POWER SUPPLY INDICATORS SHOULD COME ON (+20, +15, AND +12). THE L.O. UNLOCK INDICATOR WILL ALSO COME ON, AND AFTER SEVERAL SECONDS IT WILL GO OUT. AS LONG AS THE UNLOCK INDICATOR IS ON, THERE WILL BE NO RF OUTPUT FROM THE UNIT. AS SOON AS THE INDICATOR GOES OUT THERE WILL BE ABOUT TWO WATTS OF RF OUT OF THE UNIT. WITH A SMALL FLAT BLADE SCREWDRIVER, TURN THE PWR ADJ CONTROL SLOWLY CLOCKWISE. THE POWER WILL COME UP TO ABOUT TWENTY WATTS. THE POWER LEVEL WILL BE ADJUSTED FOR THE REQUIRED DRIVE LEVEL OF THE DEVICE BEING DRIVEN. THE EXCITER IS A WIDEBAND UNIT AND DOES NOT REQUIRE ANY TUNING OVER THE ENTIRE FM BROADCAST BAND. TURN THE PWR ADJ CONTROL TO MINIMUM POWER SWITCH TO THE OFF POSITION. THIS COMPLETES THE PRELIMINARY CHECKOUT OF THE UNIT.

WHEN USING THE EXCITER TO DRIVE AN AMPLIFIER THAT WILL PRESENT HIGH VSWR CONDITIONS TO THE EXCITER IT IS RECOMMENDED THAT A CIRCULATOR OR ISOLATOR BE USED BETWEEN THE EXCITER AND THE DEVICE BEING DRIVEN.

### REAR PANEL CONNECTIONS

THERE ARE SEVERAL CONNECTIONS ON THE REAR PANEL FOR INPUT SIGNALS AND CONTROL SIGNALS TO CONTROL THE OPERATION OF THE EXCITER.

## MODULATION INPUT SIGNALS

LOOKING AT THE REAR PANEL OF THE EXCITER THERE ARE FOUR BNC CONNECTORS MOUNTED ON THE RIGHT SIDE AND ARE LABELED ACCORDING TO THEIR RESPECTIVE INPUT FUNCTION (SC1, SC2, SC3, AND MPX) TO THE LEFT OF EACH INPUT CONNECTOR IS A CONTROL TO CONTROL THE INPUT LEVEL OF EACH INPUT. JUST BENEATH THE BNC CONNECTORS IS A 10 TERMINAL STRIP. PLUS 1 AND 3 OF THIS STRIP IS THE MONO INPUT, WHILE PIN 2 IS GROUND.

## MONITOR AND CONTROL SIGNALS

ON THE 10 TERMINAL STRIP LOCATED BENEATH THE MODULATION INPUT CONNECTORS ARE SEVERAL MONITOR AND CONTROL CONNECTIONS. PIN 8 MONITORS THE DC POWER SUPPLY VOLTAGE TO THE RF AMPLIFIER AND WILL BE IN THE RANGE OF 2 TO 19 VDC DEPENDING ON THE RF OUTPUT LEVEL. PIN 4 MONITORS THE RF POWER OUT AND IS ABOUT 11 VOLTS FOR 20 WATTS OUT. PIN 6 MONITORS THE REFLECTED POWER OUT. PIN 5 AND 7 ARE GROUND AND PIN 10 IS THE DC POWER SUPPLY VOLTAGE ISOLATED THROUGH A 1K OHM RESISTOR FOR CONTROLLING A REMOTE DEVICE. PIN 9 IS RESERVED FOR EXTERNAL CONTROL OF THE EXCITER POWER OUTPUT. ON THE LEFT SIDE OF THE REAR PANEL IS ANOTHER BNC CONNECTOR LABELED REMOTE. PLACING A GROUND ON THE CENTER PIN OF THIS CONNECTOR WILL SHUT DOWN THE POWER SUPPLY AND THE RF OUTPUT WILL GO TO ZERO. REMOVING THE GROUND WILL PLACE THE UNIT BACK INTO NORMAL OPERATION. THIS MAY BE USED TO REMOTELY SHUT THE EXCITER DOWN.

## EXTERNAL REFERENCE

THE SST-30 EXCITER MAY BE PHASE LOCKED TO AN EXTERNAL SOURCE OF 1 khz. A BNC CONNECTOR IS SUPPLIED ON THE REAR PANEL AND A JUMPER MAY BE CHANGED ON THE MAIN BOARD TO IMPLEMENT THIS OPTION.

## ADJUSTMENTS

ALL ADJUSTMENTS TO SIGNAL SHOULD BE DONE AS REQUIRED FROM THE FRONT AND REAR PANELS. ALL INTERNAL ADJUSTMENTS HAVE BEEN SET AT THE FACTORY AND SHOULD NEED NO FURTHER ADJUSTMENT. IN CASE OF REPAIRS, ALIGNMENT INSTRUCTIONS HAVE BEEN INCLUDED IN THE ALIGNMENT SECTION.

## MAINTENANCE

CAUTION: IT IS ADVISABLE TO REMOVE POWER FROM THE UNIT PRIOR TO SERVICING TO AVOID POSSIBLE SHOCK TO PERSONNEL OR DAMAGE TO THE UNIT.

THE SST-30 EXCITER WAS DESIGNED TO OPERATE RELIABLY UNDER CONTINUOUS DUTY CONDITIONS WITH A VERY MINIMUM OF MAINTENANCE. AS THE UNIT IS A WIDE BAND EXCITER, IT WILL REQUIRE NO TUNING. THE ONLY RECOMMENDED MAINTENANCE IS THAT OF PERIODIC CLEANING OF THE UNIT TO ENSURE THAT ALL AIR PASSAGES STAY FREE OF DIRT AND CONTAMINATION. THE PRINTED CIRCUIT BOARDS SHOULD ALSO BE CLEANED BY BLOWING THE DIRT OFF WITH AIR PRESSURE. DO NOT USE SOLVENTS TO CLEAN THE UNIT AS THEY MAY CAUSE DAMAGE TO SOME OF THE COMPONENTS OR FINISH OF THE UNIT.



## FUSES

TO REPLACE THE AC LINE FUSE, REMOVE THE LINE CORD FROM THE BACK OF THE UNIT. WITH A SMALL FLAT BLADE SCREWDRIVER, REMOVE THE SQUARE VOLTAGE CONFIGURATION BLOCK. THE FUSE IS LOCATED INSIDE. REPLACE THE FUSE AND THEN REPLACE THE CLOCK INSURING THAT THE WHITE ARROW IS NEXT TO THE VOLTAGE DESIRED WHEN THE BLOCK HAS BEEN REINSTALLED.

TO REPLACE THE DC FUSE, REMOVE THE TOP PANEL. THE DC FUSE IS LOCATED ON THE REGULATOR BOARD ON THE RIGHT SIDE OF THE UNIT FACING THE FRONT PANEL.

## INTEGRATED CIRCUITS

ALL INTEGRATED CIRCUITS HAVE BEEN MADE EASY BY THE USE OF SOCKETS FOR THESE DEVICES. AN IC PULLER TOOL IS RECOMMENDED FOR REMOVING THE IC CHIPS AND AN INSERTION DEVICE IS RECOMMENDED FOR REPLACING THE CHIPS TO PREVENT BENDING THE PINS. WHEN REPLACING THE CHIPS INSURE THAT ALL PINS ON THE CHIP ARE MATCHED UP WITH THE SOCKET TO INSURE GOOD CONTACT.

## RF AND POWER TRANSISTORS

TO REPLACE RF AND POWER TRANSISTORS, A FEW TOOLS WILL BE REQUIRED AS THE DEVICES ARE SOLDERED AND BOLTED INTO THE UNIT. TO UNSOLDER THE DEVICES ALWAYS USE APPROVED DESOLDERING TOOLS SUCH AS SOLDER WICK AND SOLDER SUCKERS. IN THE CASE OF RF TRANSISTOR, AFTER REMOVING THE SOLDER, CAREFULLY LIFT THE TABS CLEAR OF THE BOARD BEING CAREFUL NOT TO DAMAGE THE FOIL ON THE PRINTED CIRCUIT BOARD. MAKE A DIAGRAM OF ALL COMPONENTS REMOVED TO ENSURE THEIR PROPER REPLACEMENT IN THE EXACT POSITIONS FROM WHICH THEY CAME. WHEN REPLACING COMPONENTS USE DOW CORNING 340 HEAT SINK COMPOUND OR EQUIVALENT ON THE POWER DEVICE FOR PROPER TRANSFER OF HEAT TO THE HEAT SINK. USE GOOD SOLDERING PRACTICES WHEN RESOLDERING THE DEVICES BACK IN. WHEN SOLDERING IS COMPLETE, USE AN APPROVED SOLDER FLUX REMOVER TO CLEAN UP THE AREA WHERE THE COMPONENT WAS REPLACED. ALWAYS INSPECT THE POWER DEVICE CAREFULLY FOR INSULATING HARDWARE WHICH ELECTRICALLY INSULATES SOME OF THE DEVICES FROM THE CHASSIS GROUND. THESE WILL BE FOUND ON THE POWER TRANSISTORS AND REGULATORS IN THE POWER SUPPLY. THIS HARDWARE MUST BE REPLACED FOR THE DEVICE TO WORK PROPERLY.

## SMALL COMPONENTS

SMALL COMPONENTS, SUCH AS RESISTORS, CAPACITORS AND SMALL TRANSISTORS AND DIODES, SHOULD BE REMOVED VERY CAREFULLY USING GOOD DESOLDERING TOOLS. ALWAYS OBSERVE THE POLARITY OF DIODES AND ELECTROLYTIC CAPACITORS AND MAKE A SMALL NOTE TO ENSURE THAT THE REPLACEMENT DEVICE IS INSTALLED PROPERLY. DIODES INSTALLED WRONG MAY CAUSE DAMAGE TO OTHER COMPONENTS AND ELECTROLYTIC CAPACITORS MAY EXPLODE IF POLARITY IS NOT OBSERVED. WHEN REMOVING SMALL COMPONENTS, THE COMPONENT MAY BE CRUSHED WITH A PAIR OF PLIERS AND EACH LEAD CAREFULLY REMOVED. THE IMPORTANT ITEM IS NOT TO DAMAGE THE PRINTED CIRCUIT BOARD. THE DAMAGE MOST LIKELY TO OCCUR IS THE LIFTING OF FOIL OR THE REMOVAL OF THE PLATED MATERIAL ON A PLATED-THROUGH HOLE IN THE BOARD. IF IT IS

SUSPECTED THAT THE PLATED THROUGH MATERIAL HAS BEEN DAMAGED, THE COMPONENT LEAD MAY BE SOLDERED ON BOTH SIDES OF THE BOARD.

### ALIGNMENT

THE SST-30 EXCITER WAS ALIGNED AT THE FACTORY AND SHOULD NOT NEED FURTHER ADJUSTMENT EXCEPT FROM THE FRONT AND REAR PANELS. HOWEVER, IN THE CASE OF COMPONENT REPLACEMENT, SOME ADJUSTMENT MAY BE NECESSARY.

### POWER SUPPLY

THE EXCITER HAS BEEN SET AT THE FACTORY FOR AUTOMATIC LEVEL CONTROL OF THE RF OUTPUT, R17 IS THE FRONT PANEL LEVEL CONTROL AND SETS THE REFERENCE LEVEL FOR THE POWER SUPPLY VOLTAGE. WITH R17 SET FULLY CLOCKWISE, SET R1 ON THE POWER SUPPLY BOARD FOR 30 WATTS OUTPUT. R1 SETS THE GAIN OF U2A WHICH SAMPLES THE RF OUTPUT OF THE EXCITER. WHEN THE EXTERNAL CONTROL OPTION IS USED, THE SETTING IS CONTROLLED BY THE CONTROL R4 LOCATED ON THE AUDIO INPUT BOARD ON THE REAR PANEL. THIS WOULD MOST LIKELY BE USED TO SAMPLE THE OUTPUT OF AN AMPLIFIER AND KEEP THIS OUTPUT OF THE EXCITER DOES NOT EXCEED 30 WATTS.

### AUDIO, MULTIPLEX AND SCA

THE MULTIPLEX AND SCA INPUTS MAY BE ADJUSTED BY CONTROLS LOCATED ON THE REAR PANEL. THE MONO INPUT IS BALANCED AND HAS NO INPUT AMPLITUDE CONTROL. THE BALANCE OF THE MONO INPUT MAY BE ADJUSTED BY TYING THE PLUS AND MINUS MONO INPUT TOGETHER AND PLACING A SIGNAL ON THE INPUT. WITH AN OSCILLOSCOPE ON PIN 7 OF U1B, ADJUST R20 FOR MINIMUM SIGNAL. R23 ADJUSTS THE MONO SIGNAL GAIN INTO THE MIXER U1D. THIS SHOULD ONLY BE ADJUSTED WITH THE USE OF A MODULATION MONITOR. R8 ON THE COMPOSITE INPUT SET THE RATIO OF COMPOSITE TO SCA. WITH A LEVEL OF 2.2 VOLTS PEAK TO PEAK INPUT ON COMPOSITE AND SCA, THE OUTPUT AT PIN 14 OF U1D IS 2.1 VOLTS PEAK TO PEAK FOR MPX AND MONO AND 0.3 VOLTS PEAK TO PEAK FOR SCA. R34 IS SET FOR MINIMUM DISTORTION AND SHOULD ONLY BE ADJUSTED IF THE PROPER EQUIPMENT IS AVAILABLE. FINAL DEVIATION ADJUSTMENT MAY BE MADE WITH R35. R36 ADJUSTS THE BIAS POINT FOR THE VARICAP DIODE IN THE VCO AND IS ADJUSTED FOR 5.7 VOLTS DC AT THE JUNCTION OF R36 AND R37. R33 CALIBRATES THE FRONT PANEL METER FOR DEVIATION. THIS SHOULD BE CALIBRATED USING A SINGLE TONE.

### VSWR METER

THE METER ON THE FRONT PANEL MAY BE CALIBRATED FOR RF POWER WITH R4 AND R5 ON THE EUROCARD LOCATED ON THE FRONT PANEL. R4 CALIBRATES THE FORWARD POWER READING AND R5 CALIBRATES THE REFLECTED POWER READING. THIS SHOULD BE DONE USING A CALIBRATED POWER METER SUCH AS A BIRD MODEL 43 OR EQUIVALENT.

PARTS LIST FOR SST-30 POWER SUPPLY

	<u>STOCK #</u>		<u>STOCK #</u>
CN1 CONNECTOR 26 PIN	001-100	L3 RF CHOKE	001-115
CN2 CONNECTOR BNC	001-101		
C1 47NF CERAMIC	001-102	Q1 TRANSISTOR HJ3001	001-116
C2 47NF CERAMIC	001-103	R1 RESISTOR 4.7K OHM	001-117
C3 4.7NF CERAMIC	001-103	R2 RESISTOR 4.7K OHM	001-117
C4 1NF CERAMIC	001-104	R3 RESISTOR 10 OHM	001-118
C5 10UF ELECTROLYTIC	001-105	R4 RESISTOR 10K OHM	001-119
C6 10UF ELECTROLYTIC	001-105	R5 RESISTOR 1K OHM	001-120
C7 470PF CERAMIC	001-106	R6 RESISTOR 10K OHM	001-119
C8 470PF CERAMIC	001-106	R7 RESISTOR 1K OHM	001-120
C9 10PF CERAMIC	001-107	R8 RESISTOR 12K OHM	001-121
C10 1-PF CERAMIC	001-107	R9 RESISTOR 12K OHM	001-121
C11 470PF CERAMIC	001-106	R10 RESISTOR 10K OHM	001-119
C12 47PF CERAMIC	001-106	R11 RESISTOR 4.7K OHM	001-117
C13 470PF CERAMIC	001-106	R12 RESISTOR 4.7K OHM	001-117
C14 10UV ELECTROLYTIC	001-105	R13 RESISTOR 4.7K OHM	001-117
C15 10NF CERAMIC	001-108	R14 RESISTOR 4.7K OHM	001-117
C16 33UF ELECTROLYTIC	001-109	R15 RESISTOR 100K OHM	001-122
C17 470PF CERAMIC	001-106	R16 RESISTOR 33K OHM	001-123
C18 10NF CERAMIC	001-108	R17 RESISTOR 27K OHM	001-124
C19 100UF ELECTROLYTIC	001-110	R18 RESISTOR 330 OHM	001-125
C20 10KUF CERAMIC	001-108	R19 RESISTOR 4.7K OHM	001-117
C21 33UF ELECTROLYTIC	001-109	R20 RESISTOR 1.8K OHM	001-126
C22 10,000UF ELECTROLYTIC	001-110	R21 RESISTOR 10 OHM	001-118
C23 10,000UF ELECTROLYTIC	001-110	R22 RESISTOR 10K OHM	001-119
C24 10UF ELECTROLYTIC	001-105	R23 RESISTOR 220 OHM	001-127
C25 10UF ELECTROLYTIC	001-105	R24 RESISTOR .22 OHM	001-128
C26 10UF ELECTROLYTIC	001-105	R25 RESISTOR .22 OHM	001-128
C27 10UF ELECTROLYTIC	001-105	R26 RESISTOR 10 OHM	001-118
C28 4.7NF CERAMIC	001-103	R27 RESISTOR 1K OHM	001-120
C29 4.7NF CERAMIC	001-103	R28 RESISTOR 220 OHM	001-127
		R29 RESISTOR 10K OHM	001-119
D1 NOT USED		R30 RESISTOR 2.2K OHM	001-129
D2 NOT USED		R31 RESISTOR 18K OHM	001-130
D3 ZENER DIODE 24V	001-111	R32 RESISTOR 2.7K OHM	001-131
D4 DIODE 1N4148	001-112	R33 RESISTOR 22K OHM	001-132
D5 DIODE 1N4004	001-113	R34 RESISTOR 22KOHM	001-132
D6 DIODE 1N4004	001-113	R35 RESISTOR 1K OHM	001-120
D7 DIODE 1N4004	001-113		
D8 DIODE 1N4004	001-113	SWI SWITCH SPST PWR	001-133
D9 DIODE BRIDGE 26MB10A	001-114	T1 XFMR PWR 22VAC6AMP	001-134
F1 FUSE 2 AMP	001-135	U1 REGULATOR LM723	001-140
F2 FUSE 4 AMP	001-136	U2 OPANO LM358N	001-141
		U3 REGULATOR LM7815	001-142
	<u>STOCK #</u>		<u>STOCK #</u>
FAN1 220 VOLT FAN	001-137	U4 REGULATOR LM 7812	001-143
LP1 LAMP LPN 220V	001-138		
L1 RF CHOKE	001-139		
L2 RF CHOKE	001-139		

PARTS LIST SST-30  
AUDIO INPUT

<u>SYMBOL</u>	<u>STOCK #</u>	<u>DESCRIPTION</u>
CN1	001-144	CONNECTOR BNC
CN2	001-144	CONNECTOR BNC
CN3	001-144	CONNECTOR BNC
CN4	001-144	CONNECTOR BNC
CN5	001-145	TERMINAL STRIP 10 PIN
CN6	001-146	CONNECTOR, 26 PIN
CN7	001-146	CONNECTOR, 26 PIN
C1-C5	001-147	CAPACITOR, 1NF. CERAMIC
R1-F3	001-120	RESISTOR, 1K OHM
R4	001-148	RESISTOR, VAR.47K
R5-R8	001-149	RESISTOR, VAR.10K

**PARTS LIST SST-30  
MAIN BOARD**

	<u>STOCK #</u>		<u>STOCK #</u>
C1	560PF CERAMIC	001-150	C48 4.7NF CERAMIC 001-103
C2	560PF CERAMICD	001-150	C49 4.7NF CERAMIC 001-103
C3	560PF CERAMIC	001-150	C50 27PF CERAMIC 001-158
C4	10PF CERAMIC	001-151	C51 4.7 CERAMIC 001-103
C5	39PF CERAMIC	001-152	C52 1NF CERAMIC 001-104
C6	39PF CERAMIC	001-152	C53 100PF CERAMIC 001-157
C7	39PF CERAMIC	001-152	C54 4.7NF CERAMIC
C8	39PF CERAMIC	001-152	C56 100NF CERAMIC 001-155
C10	39PF CERAMIC	001-152	C57 4.7NF CERAMIC 001-103
C11	39PF CERAMIC	001-152	C58 4.7NF CERAMIC 001-103
C12	39PF CERAMIC	001-152	C59 NOT USED
C13	100UF ELECTROLYTIC	001-110	C60 4.7NF CERAMIC 001-103
C14	39PF CERAMIC	001-152	C61 100UF ELECTROLYTIC 001-110
C15	39PF CERAMIC	001-152	C62 NOT USED
C16	39PF CERAMIC	001-152	C63 4.7NF CERAMIC 001-103
C17	39PF CERAMIC	001-152	C64 4.7NF CERAMIC 001-103
C18	100UF ELECTROLYTIC	001-110	C65 4.7NF CERAMIC 001-103
C19	100UF ELECTROLYTIC	001-110	C66 4.7NF CERAMIC 001-103
C20	47UF ELECTROLYTIC	001-153	C67 220PF CERAMIC 001-158
C21	1NF CERAMIC	001-104	C68 4.7NF CERAMIC 001-103
C22	1NF CERAMIC	001-104	C69 4.7 CERAMIC 001-103
C23	1NF CERAMIC	001-104	C70 2.2PF CERAMIC 001-159
C24	1NF CERAMIC	001-104	C71 1NF CERAMIC 001-104
C25	100UF ELECTROLYTIC	001-110	C72 NOT USED
C26	10UF ELECTROLYTIC	001-105	C73 NOT USED
C27	47UF ELECTROLYTIC	001-153	C74 NOT USED
C28	47UF ELECTROLYTIC	001-153	C75 NOT USED
C29	2.2UF ELECTROLYTIC	001-154	C76 NOT USED
C30	100UF ELECTROLYTIC	001-110	C77 NOT USED
C31	10UF ELECTROLYTIC	001-105	C78 NOT USED
C32	10PF CERAMIC	001-151	C79 NOT USED
C33	10UF ELECTROLYTIC	001-105	C80 NOT USED
C34	470PF CERAMIC	001-106	C81 1UF ELECTROLYTIC 001-160
C35	100NF CERAMIC	001-155	C82 100NF CERAMIC 001-155
C36	100UF ELECTROLYTIC	001-110	C83 47UF ELECTROLYTIC 001-153
C37	10NF CERAMIC	001-108	C84 18PF CERAMIC 001-161
C38	47PF CERAMIC	001-156	C85 60PF CERAMIC 001-162
C39	4.7NF CERAMIC	001-103	C86 47NF CERAMIC 001-102
C40	1NF CERAMIC	001-104	C87 47NF CERAMIC 001-102
C41	10UF ELECTROLYTIC	001-105	C88 33PF CERAMIC 001-163
C42	100UF ELECTROLYTIC	001-110	C89 560 PF CERAMIC 001-150
C43	100 ELECTROLYTIC	001-110	C90 10UF ELECTROLYTIC 001-105
C44	4.7NF CERAMICD	001-103	C91 10UF ELECTROLYTIC 001-105
C45	1NF CERAMIC	001-104	C92 47NF CERAMIC 001-102
C46	100PF CERAMIC	001-157	C93 47NF CERAMIC 001-102
C47	100UF ELECTROLYTIC	001-110	C94 10UF ELECTROLYTIC 001-105

	<u>STOCK #</u>		<u>STOCK #</u>	
C95	100NF CERAMIC	001-155	L3 RF CHOKE	001-169
C96	10UF ELECTROLYTIC	001-105	L4 RF CHOKE	001-169
C97	10UF ELECTROLYTIC	001-105	L5 RF CHOKE	001-169
C98	10UF ELECTROLYTIC	001-105	L6 RF CHOKE	001-169
C99	2.2UF ELECTROLYTIC	001-154	L7 RF CHOKE	001-169
C100	10NF CERAMIC	001-108	L8 RF CHOKE	001-169
C101	100UF ELECTROLYTIC	001-110	L9 RF CHOKE	001-169
C102	10UF ELECTROLYTIC	001-105	L10 22UH COIL	001-170
C103	100NF CERAMIC	001-155	L11 2.2UH COIL	001-171
C104	10UF ELECTROLYTIC	001-105	L12 INDUCTOR COAX	001-172
C105	22UF ELECTROLYTIC	001-164	L13 INDUCTOR COAX	001-172
C106	100NF CERAMIC	001-155	L14 2.2UH COIL	001-171
C107	10UF ELECTROLYTIC	001-105	L15 2.2UH COIL	001-171
C108	10UF ELECTROLYTIC	001-105	L16 TORIOD OHM 10MM	001-173
C109	100NF CERAMIC	001-155	L17 220UH COIL	001-174
C110	47UF ELECTROLYTIC	001-153	L18 RF CHOKE	001-169
C111	10UF ELECTROLYTIC	001-105	L19 2.2UH COIL	001-171
C112	100NF CERAMIC	001-155	L20 2.2UH COIL	001-171
C113	100NF CERAMIC	001-155	L21 RF CHOKE	001-169
C114	100NF CERAMIC	001-155		
C115	100NF CERAMIC	001-155	Q1 NOT USED	
C116	10UF ELECTROLYTIC	001-105	Q2 TRANSISTOR J310	001-175
			Q3 TRANSISTOR 2N918	001-176
C117	100NF CERAMIC	001-155	Q4 TRANSISTOR 2N918	001-176
C118	4.7NF CERAMIC	001-103	Q5 TRANSISTOR BC237	001-177
C119	10UF ELECTROLYTIC	001-105	Q6 TRANSISTOR BCY59	001-178
			Q7 TRANSISTOR 2N918	001-176
D1	DIODE 1N4148	001-112	Q8 TRANSISTOR 2N3866	001-179
D2	DIODE 1N4148	001-112	Q9 TRANSISTOR 2N3866	001-179
D3	VARICAP MV209	001-165	Q10 TRANSISTOR BCY59	001-180
D4	VARICAP MV209	001-165	Q11 TRANSISTOR BFR96	001-180
D5	VARICAP MV209	001-165	Q12 NOT USED	
D6	VARICAP MV209	001-165	Q13 TRANSISTOR BF245B	001-181
D7	ZENER DIODE 6.8V	001-166	Q14 TRANSISTOR 2N918	001-176
D8	DIODE 1N4148	001-112	Q15 TRANSISTOR BC237	001-177
D9	DIODE 1N4148	001-112		
D10	ZENER DIODE 5.6V	001-167	RR1 RESISTOR ARRAY1.5K	001-182
D11	ZENER DIODE 5.6V	001-167	RR2 RESISTOR ARRAY1.5K	001-182
D12	DIODE 1N4148	001-112	R1 RESISTOR 33K OHM	001-183
D13	DIODE 1N4148	001-112	R2 RESISTOR 33K OHM	001-183
D14	NOT USED		R3 RESISTOR 33K OHM	001-183
D15	DIODE 1N4148	001-112	R4 RESISTOR 22K OHM	001-132
D16	DIODE 1N4148	001-112	R5 RESISTOR 220K OHM	001-184
D17	DIODE 1N4148	001-112	R6 RESISTOR 220K OHM	001-184
D18	DIODE 1N4148	001-112	R7 RESISTOR 220K OHM	001-184
D19	DIODE 1N4148	001-112	R8 RESISTOR 47K OHM	001-185
D20	DIODE HP2800	001-168	R9 RESISTOR 600 OHM	001-186
D21	DIODE HP2800	001-168	R10 RESISTOR 10K OHM	001-119
D22	DIODE 1N4148	001-112	R11 RESISTOR 100K OHM	001-122
D23	DIODE 1N4148	001-112	R12 RESISTOR 100K OHM	001-122
D24	DIODE 1N4148	001-112	R13 RESISTOR 6.8K OHM	001-187
D25	DIODE 1N4148	001-112	R14 RESISTOR 6.8K OHM	001-187
L3	RF CHOKE	001-169	R15 RESISTOR 12K OHM	001-121

	<u>STOCK #</u>		<u>STOCK #</u>
L2 RF CHOKE	001-169	R16 RESISTOR 39K OHM	001-188
R17 RESISTOR 10K OHM	001-119	R70 RESISTOR 1MEG OHM	001-193
R18 RESISTOR 39K OHM	001-188	R71 RESISTOR 8.2K OHM	001-203
R19 RESISTOR 10K OHM	001-119	R72 RESISTOR 1K OHM	001-120
R20 RESISTOR 22K OHM	001-132	R73 RESISTOR 8.2 OHM	001-201
R21 RESISTOR 47K OHM	001-185	R74 RESISTOR 5.6K OHM	001-204
R22 RESISTOR 2.2KOHM	001-129	R75 RESISTOR 1.2K OHM	001-205
R23 RESISTOR 47K OHM	001-185	R76 RESISTOR 270 OHM	001-206
R24 RESISTOR 12K OHM	001-121	R77 RESISTOR 330 OHM	001-207
R25 RESISTOR 10K OHM	001-119	R78 RESISTOR 220 OHM	001-127
R26 RESISTOR 15K OHM	001-189	R79 RESISTOR 8.2K OHM	001-203
R27 RESISTOR 10K OHM	001-119	R80 RESISTOR 10 OHM	001-118
R28 RESISTOR 100 OHM	001-190	R81 RESISTOR 100 OHM	001-190
R29 RESISTOR 2.2K OHM	001-129	R82 RESISTOR 56 OHM	001-208
R30 RESISTOR 6.8K	001-187	R83 RESISTOR 47 OHM	001-209
R31 RESISTOR 6.8K OHM	001-187	R84 RESISTOR 100 OHM	001-190
R32 RESISTOR 820 OHM	001-191	R85 RESISTOR 47K OHM	001-185
R33 RESISTOR 4.7K OHM	001-117	R86 RESISTOR 33K OHM	001-183
R34 RESISTOR 500 OHM	001-192	R87 RESISTOR 150K OHM	001-210
R35 RESISTOR 47K OHM	001-185	R88 RESISTOR 1.5K OHM	001-200
R36 RESISTOR 22K OHM	001-132	R89 RESISTOR 1.5K OHM	001-200
R37 RESISTOR 1MEG OHM	001-193	R90 RESISTOR 100 OHM	001-190
R38 RESISTOR 390 OHM	001-194	R91 RESISTOR 820K OHM	001-211
R39 RESISTOR 100K OHM	001-122	R92 RESISTOR 680 OHM	001-198
R40 RESISTOR 33K OHM	001-183	R93 RESISTOR 27 OHM	001-202
R41 RESISTOR 330K OHM	001-195	R94 RESISTOR 180 OHM	001-212
R42 RESISTOR 470K OHM	001-196	R95 RESISTOR 1MEG OHM	001-193
R43 RESISTOR 22 OHM	001-197	R96 RESISTOR 470 OHM	001-196
R44 RESISTOR 10K OHM	001-119	R97 RESISTOR 560 OHM	001-201
R45 RESISTOR 2.7K OHM	001-131	R98 RESISTOR 470 OHM	001-196
R46 RESISTOR 220 OHM	001-127	R99 RESISTOR 100 OHM	001-190
R47 RESISTOR 100 OHM	001-190	R100 RESISTOR 100 OHM	001-190
R48 RESISTOR 4.7K OHM	001-117	R101 RESISTOR 22K OHM	001-132
R49 RESISTOR 6.8K OHM	001-187	R102 RESISTOR 10K OHM	001-119
R50 RESISTOR 220 OHM	001-127	R103 RESISTOR 22 OHM	001-197
R51 RESISTOR 10 OHM	001-118	R104 RESISTOR 6.8K OHM	001-187
R52 RESISTOR 680 OHM	001-198	R105 RESISTOR 2.2K OHM	001-129
R53 RESISTOR 10 OHM	001-118	R106 RESISTOR 10K OHM	001-119
R54 RESISTOR 2.7K OHM	001-131	R107 RESISTOR 10K OHM	001-119
R55 RESISTOR 3.3 OHM	001-199	R108 RESISTOR 82K OHM	001-198
R56 RESISTOR 220 OHM	001-127	R109 RESISTOR 1K OHM	001-120
R57 RESISTOR 390 OHM	001-194	R110 RESISTOR 1K OHM	001-120
R58 RESISTOR 10 OHM	001-118	R111 RESISTOR 47K OHM	001-185
R59 RESISTOR 1.5K OHM	001-200	R112 RESISTOR 47K OHM	001-185
R60 RESISTOR 680 OHM	001-198	R113 RESISTOR 100K OHM	001-122
R61 RESISTOR 220 OHM	001-127	R114 RESISTOR 33K OHM	001-195
R62 RESISTOR 220 OHM	001-127	R115 RESISTOR 1K OHM	001-120
R63 RESISTOR 220 OHM	001-127	R116 RESISTOR 1K OHM	001-120
R64 RESISTOR 220 OHM	001-127	R117 RESISTOR 27 OHM	001-202
R65 RESISTOR 560 OHM	001-201	R118 RESISTOR 27K OHM	001-203
R66 RESISTOR 27 OHM	001-202	R119 RESISTOR 1.2K OHM	001-205
R67 RESISTOR 100 OHM	001-190	R120 RESISTOR 270 OHM	001-206
R68 RESISTOR 22K OHM	001-132	R121 RESISTOR 470 OHM	001-196

R69 RESISTOR 47K OHM

<u>STOCK #</u>		<u>STOCK #</u>
001-185	R122 RESISTOR 270 OHM	001-206
	R123 RESISTOR 470 OHM	001-196
	R124 RESISTOR 1.8MEGOHM	001-199
	R125 RESISTOR 10K OHM	001-119
	R126 RESISTOR 100 OHM	001-190
	R127 RESISTOR 1.5K OHM	001-200
	R128 RESISTOR 22 OHM	001-197
	R129 RESISTOR 1.5K OHM	001-200
	R130 RESISTOR 1K OHM	001-120
	R131 RESISTOR 1K OHM	001-120
	R132 RESISTOR 47 OHM	001-209
	R133 RESISTOR 75 OHM	001-212
	R134 RESISTOR 47 OHM	001-209
	R135 RESISTOR 56 OHM	001-213
	R136 RESISTOR 47 OHM	001-209
	R137 RESISTOR 47 OHM	001-209
	R138 RESISTOR 1.5K OHM	001-200
	R139 RESISTOR 1.5K OHM	001-200
	R140 RESISTOR 6.8K OHM	001-187
	R141 RESISTOR 10K OHM	001-119
	R142 RESISTOR 470 OHM	001-119
	R143 RESISTOR 270 OHM	001-196
	R144 RESISTOR 10K OHM	001-206
	R145 RESISTOR 470 OHM	001-206
	R146 RESISTOR 12K OHM	001-121
	R147 RESISTOR 47 OHM	001-214
	SW1 SWITCH 4 POLE DIP	001-215
	SW2 SWITCH 4 POLE DIP	001-215
	SW3 SWITCH 4 POLE DIP	001-215
	SW4 SWITCH 4 POLE DIP	001-215
	SW5 SWITCH 4 POLE DIP	001-215
	U1 OPAMP TL074	001-216
	U2 REGULATOR 78L08	001-217
	U3 1C 4520	001-218
	U4 1C 4046	001-219
	U5 1C 74121	001-210
	U6 1CNE5532	001-211
	U7 1C SP8680	001-212
	U8 1C 74LS02	001-213
	U9 REGULATOR LM7805	001-214
	U10 1C 74LS190	001-215
	U11 1C 74LS190	001-215
	U12 1C 74LS190	001-215
	U13 1C 74LS190	001-215
	U14 1C 74LS190	001-215
	U15 OPAMP TL082	001-216
	U16 1C 4518	001-217
	U17 1C 74196	001-218
	U18 1C 7400	001-219
	X1 CRYSTAL 4.0 MHz	001-220



**PARTS LIST SST-30  
POWER AMPLIFIER**

	<u>STOCK #</u>		<u>STOCK #</u>
ACC TOROID COIL CPLR	001-221	D1 DIODE 1N4148	001-112
		D2 DIODE 1N4148	001-112
CN1 CONNECTOR BNC	001-144		
CN2 CONNECTOR N	001-222	J1 RF CHOKE	001-169
CN3 CONNECTOR 26 PIN	001-146	J2 RF CHOKE	001-169
		J3 RF CHOKE	001-169
		J4 RF CHOKE	001-169
CV1 CAP VARIABLE 10PF	001-223		
CV2 CAP VARIABLE 10PF	001-223		
CV3 CAP VARIABLE 40PF	001-224	L1 COIL RF	001-233
		L2 COIL RF	001-234
		L3 COIL RF	001-235
C1 4.7NF CERAMIC	001-103	L4 NOT USED	001-236
C2 39 PF CERAMIC	001-152	L5 COIL RF	001-237
C3 47PF CERAMIC	001-156	L6 COIL RF	001-238
C4 100PF CERAMIC	001-157	L7 NOT USED	001-239
C5 12PF CERAMIC	001-225	L8 COIL RF	001-240
C6 12PF CERAMIC	001-225	L9 COIL RF	001-241
C7 4.7 NF CERAMIC	001-103		
C8 22PF CERAMIC	001-226		
C9 4.7NF CERAMIC	001-103	Q1 TRANSISTOR MRF237	001-242
C10 10UF ELECTROLYTIC	001-105	Q2 TRANSISTOR BLW86	001-243
C11 39PF CERAMIC	001-152		
C12 27PF CERAMIC	001-227	R1 RESISTOR 220 OHM	001-127
C13 4.7NF CERAMIC	001-103	R2 RESISTOR 2.2K OHM	001-129
C14 150PF CERAMIC	001-228	R3 RESISTOR 3.9 OHM	001-244
C15 82PF CERAMIC	001-229	R4 RESISTOR 3.9 OHM	001-245
C16 82PF CERAMIC	001-229	R5 RESISTOR 10 OHM	001-246
C17 82 PF CERAMIC	001-229	R6 RESISTOR 10 OHM	001-246
C18 82PF CERAMIC	001-229	R7 RESISTOR 15 OHM	001-247
C19 680PF CERAMIC	001-230	R8 RESISTOR 39 OHM	001-248
C20 560PF CERAMIC	001-231	R9 RESISTOR 47 OHM	001-209
C21 1NF UNELCO	001-104	R10 RESISTOR 12 OHM	001-249
C22 1NF UNELCO	001-104	R11 RESISTOR 150 OHM	001-250
C23 82PF CERAMIC	001-229	R12 RESISTOR 47 OHM	001-209
C24 82PF CERAMIC	001-229	R13 RESISTOR 47 OHM	001-209
C25 2X39PF CERAMIC	001-152	R14 RESISTOR 1K OHM	001-120
C26 4X39PF CERAMIC	001-152	R15 RESISTOR 47 OHM	001-209
C27 4.7NF CERAMIC	001-103	R16 RESISTOR 3.3K OHM	001-199
C28 2X4.7NF CERAMIC	001-103	R17 RESISTOR 47 OHM	001-209
C29 100UF ELECTROLYTIC	001-110	R18 RESISTOR 3.3K OHM	001-199
C30 27 PF CERAMIC	001-227		
C31 10PF CERAMIC	001-151	T1 4:1 WIDEBAND XMFR	001-251
C32 39PF CERAMIC	001-105	T2 4:1 WIDEBAND XMFR	001-252
C33 5.6PF CERAMIC	001-230		
C34 6.8PF CERAMIC	001-231		
C35 22PF CERAMIC	001-226		
C36 2.2PF CERAMIC	001-232		
C37 4.7NF CERAMIC	001-103		
C38 4.7NF CERAMIC	001-103		

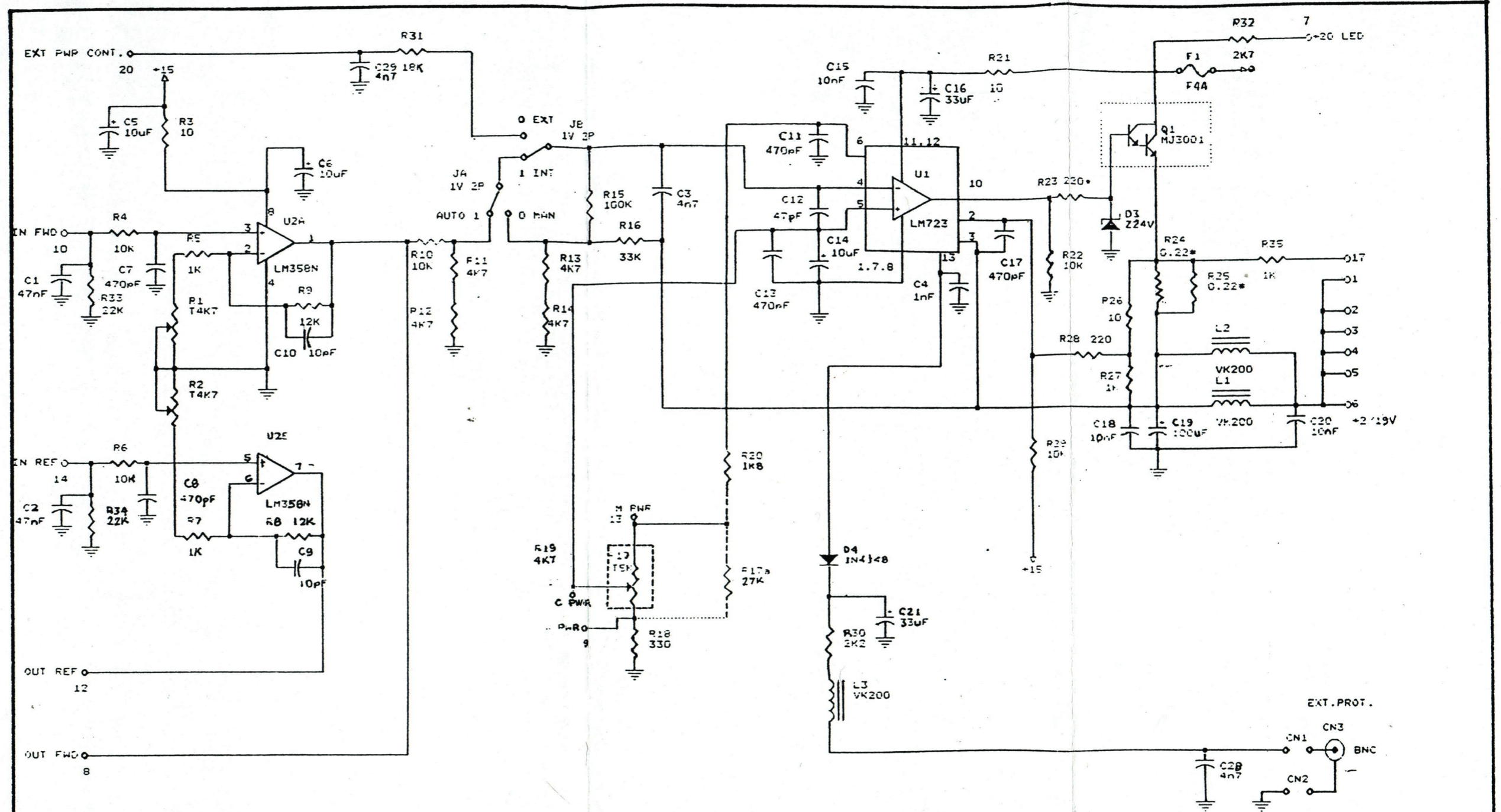

LE R=1/2 WATT  
LE R=5 WATT

If You Didn't Get This From My Site,  
Then It Was Stolen From...  
[www.SteamPoweredRadio.Com](http://www.SteamPoweredRadio.Com)

<b>ENERGY ONIX</b>		
HUDSON, N.Y		
SST 30 POWER SUPPLY (SHT. 1 OF 2)		
6 T J	1-09-95	S223

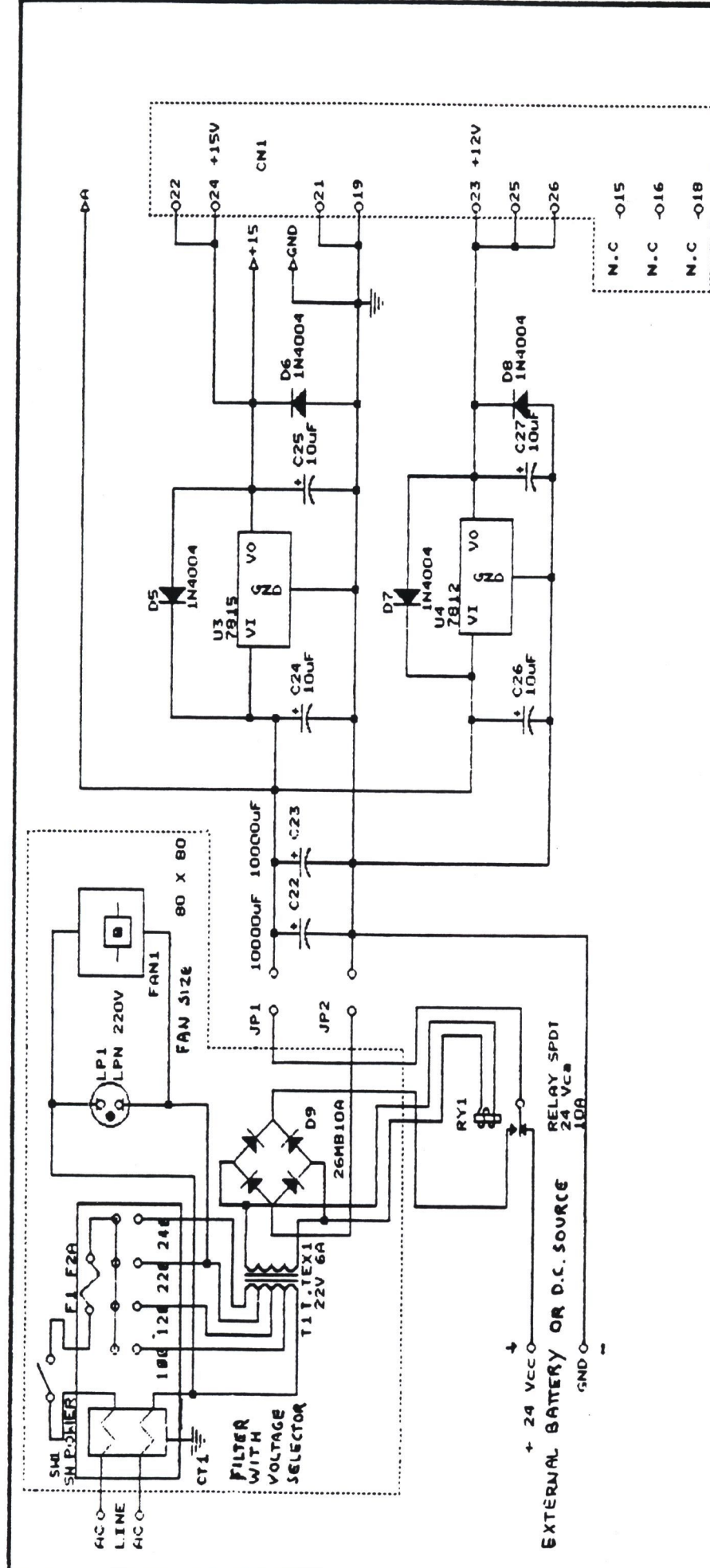

N.C -015  
 N.C -016  
 N.C -018

THE +12V OUTPUT IS ON THREE CONTACTS  
 THE +15V OUTPUT IS ON TWO CONTACTS  
 THE 24V CONNECTION IS ON SEPARATE FASTON  
 MOUNTED ON P.C. BOARD, 35 V.

# ENERGY ONIX

HUDSON, N.Y.

SS T 30 POWER SUPPLY  
 (SHT 2 OF 2)

GT J 1-09-95 S222

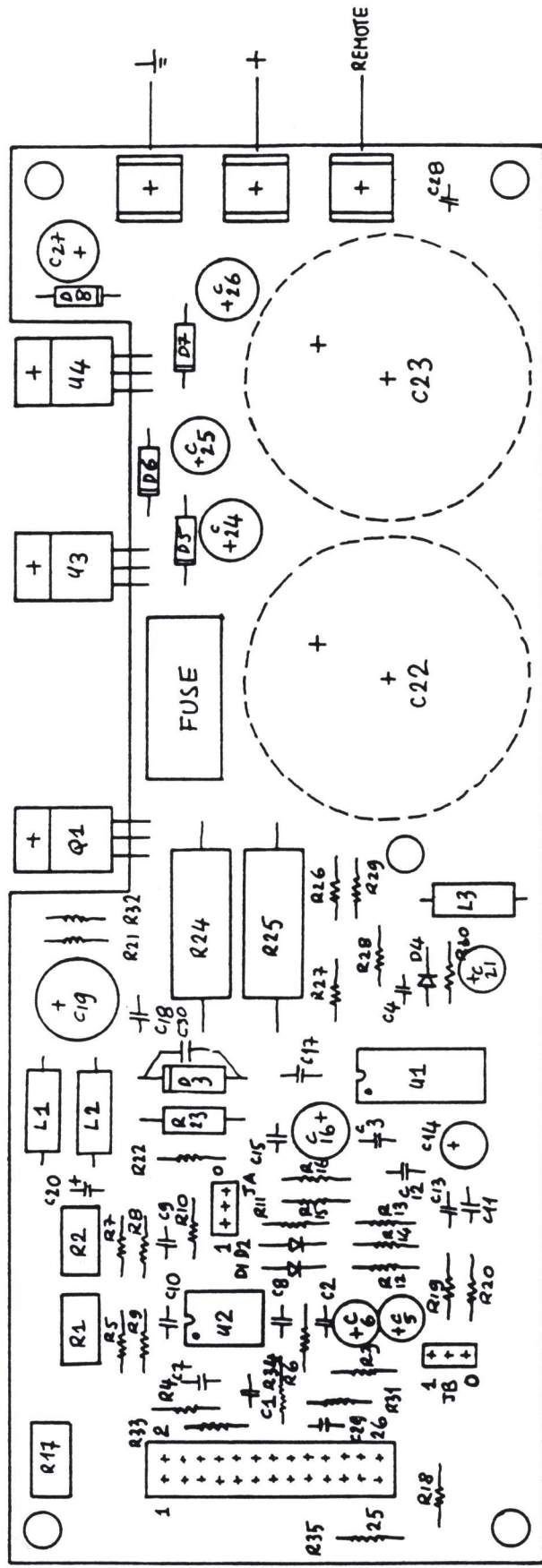

<b>ENERGY ONIX</b>	
HUDSON, N. Y.	
S S T 30 POWER SUPPLY COMPONENTS LAYOUT	
G T J	I-05-95 S2I6

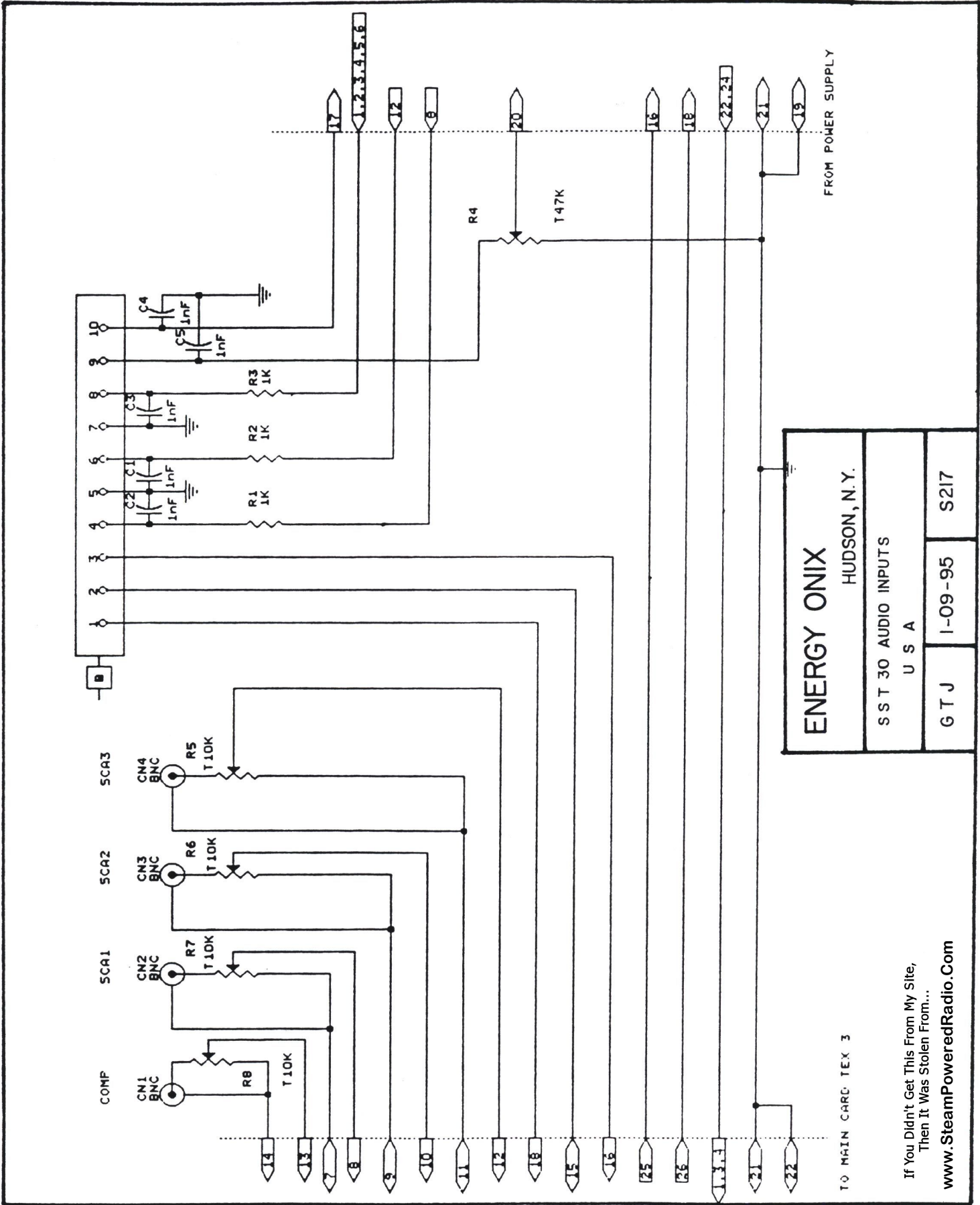

TO MAIN CARD: TEX 3

**ENERGY ONIX**  
HUDSON, N.Y.

SST 30 AUDIO INPUTS  
U S A

GTJ 1-09-95 S217

If You Didn't Get This From My Site,  
Then It Was Stolen From...  
[www.SteamPoweredRadio.Com](http://www.SteamPoweredRadio.Com)

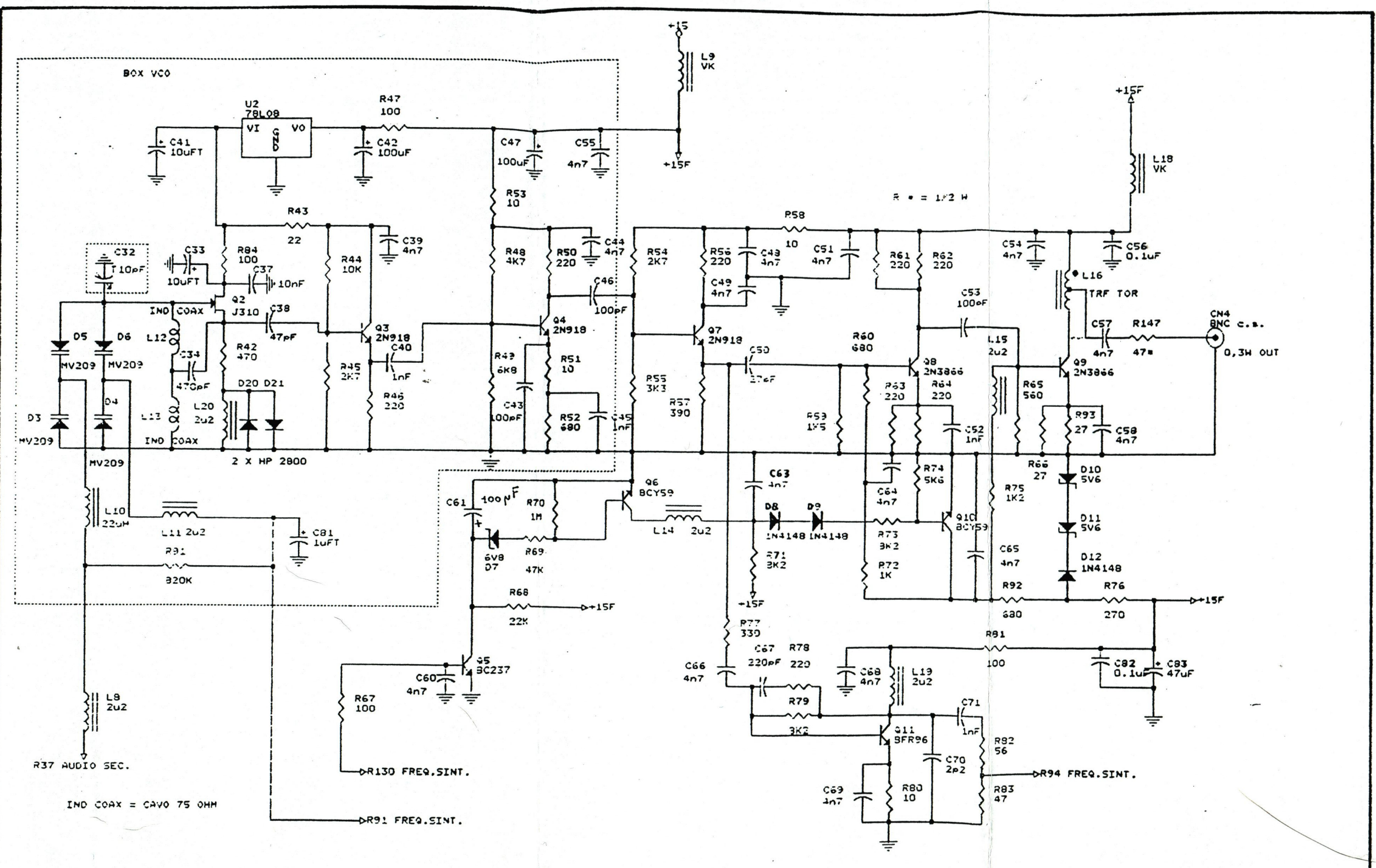

If You Didn't Get This From My Site,  
Then It Was Stolen From...  
[www.SteamPoweredRadio.Com](http://www.SteamPoweredRadio.Com)

<b>ENERGY ONIX</b>		
HUDSON, N.Y.		
SST 30 MAINBOARD, VCO AND RF DRIVER SECTION		
G T J	1-09-95	S 224

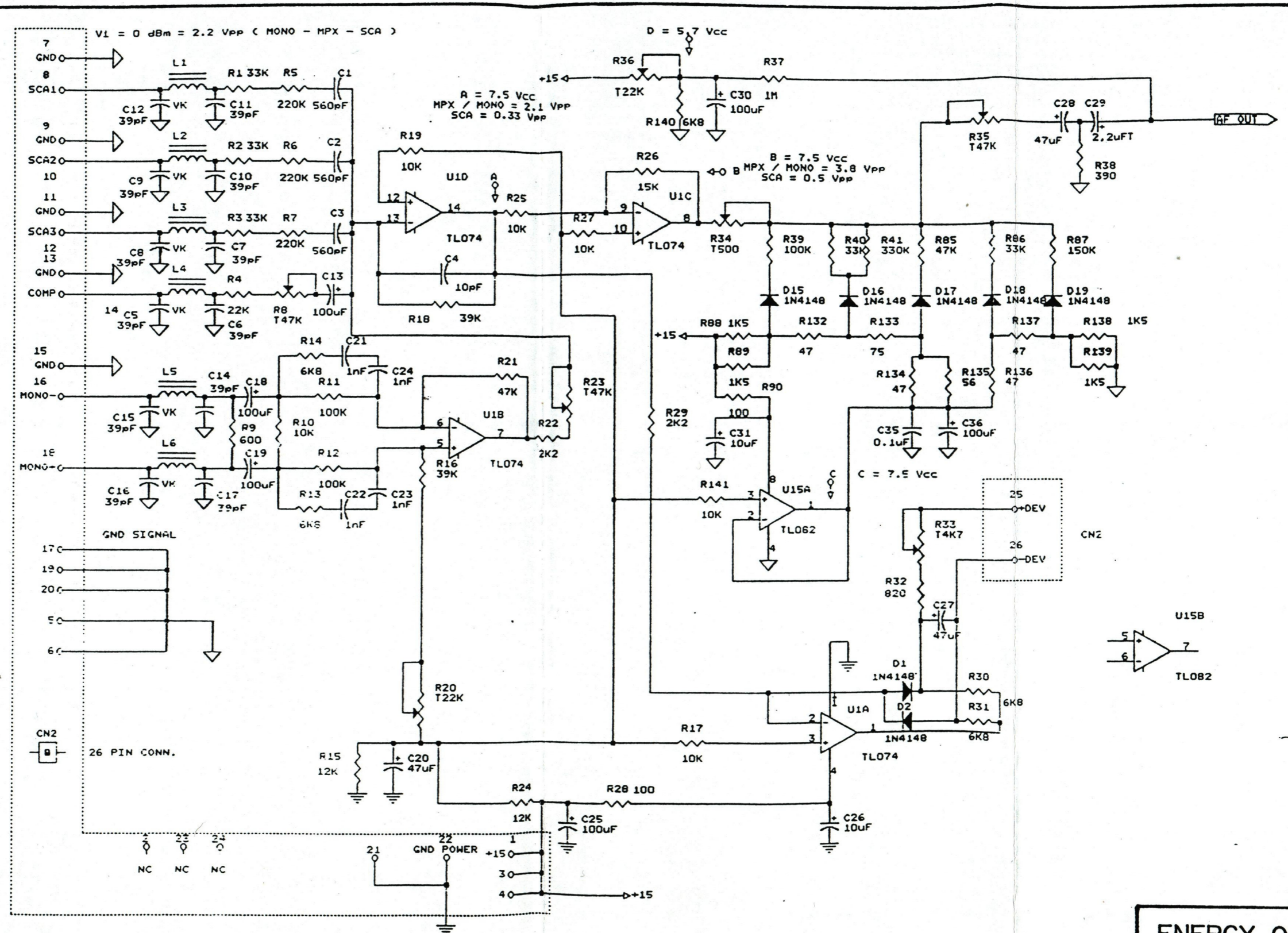

V1 = 0 dBm = 2.2 Vpp ( MONO - MPX - SCA )

A = 7.5 Vcc  
MPX / MONO = 2.1 Vpp  
SCA = 0.33 Vpp

D = 5.7 Vcc

B = 7.5 Vcc  
MPX / MONO = 3.8 Vpp  
SCA = 0.5 Vpp

C = 7.5 Vcc

If You Didn't Get This From My Site,  
Then It Was Stolen From...  
www.SteamPoweredRadio.Com

<b>ENERGY ONIX</b>		
HUDSON, N.Y.		
SST 30 MAIN BOARD AUDIO SECTION		
G T J	1-09-95	S225

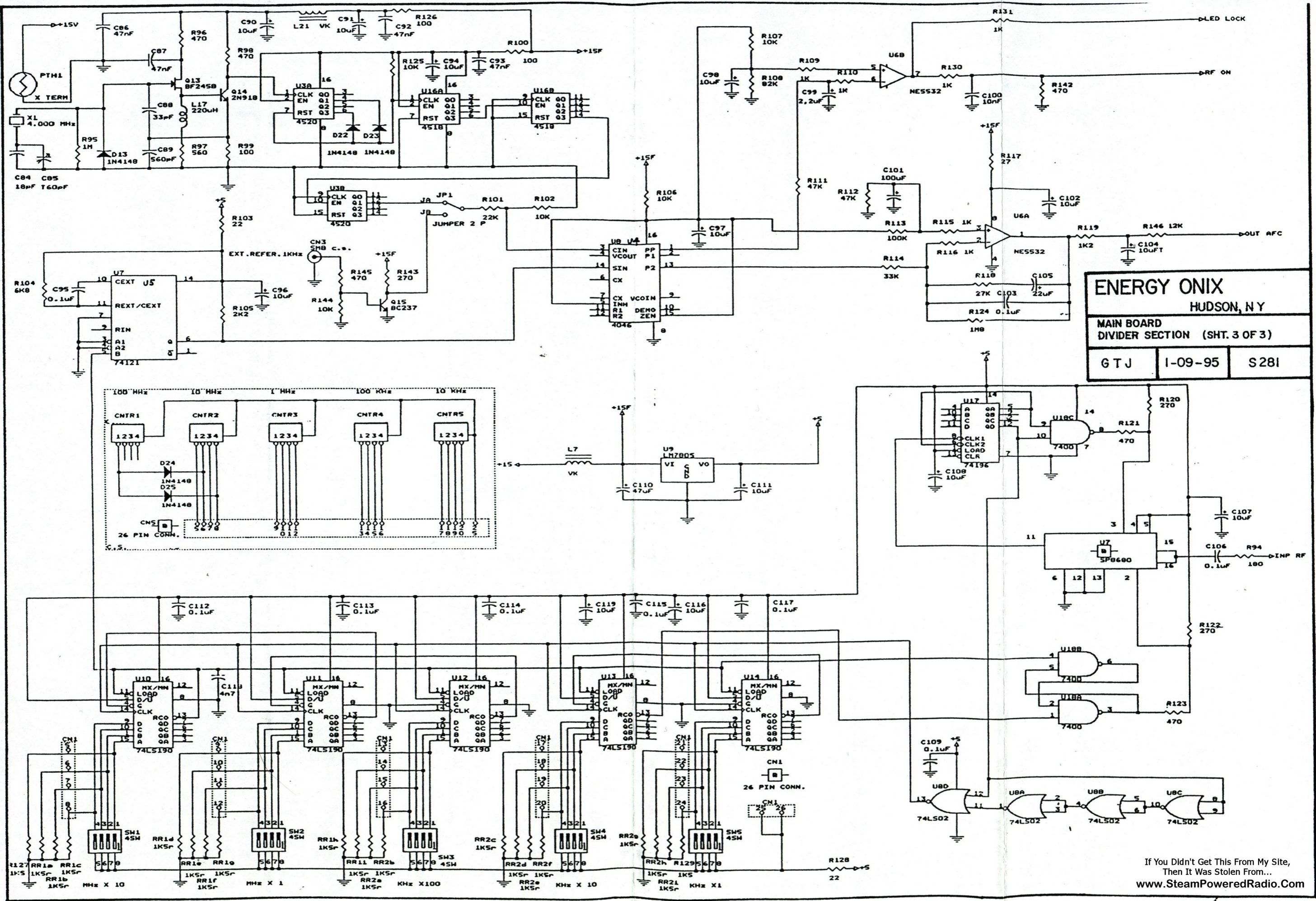

**ENERGY ONIX**  
HUDSON, N Y

MAIN BOARD  
DIVIDER SECTION (SHT. 3 OF 3)

G T J	1-09-95	S 281
-------	---------	-------

If You Didn't Get This From My Site,  
Then It Was Stolen From...  
[www.SteamPoweredRadio.Com](http://www.SteamPoweredRadio.Com)



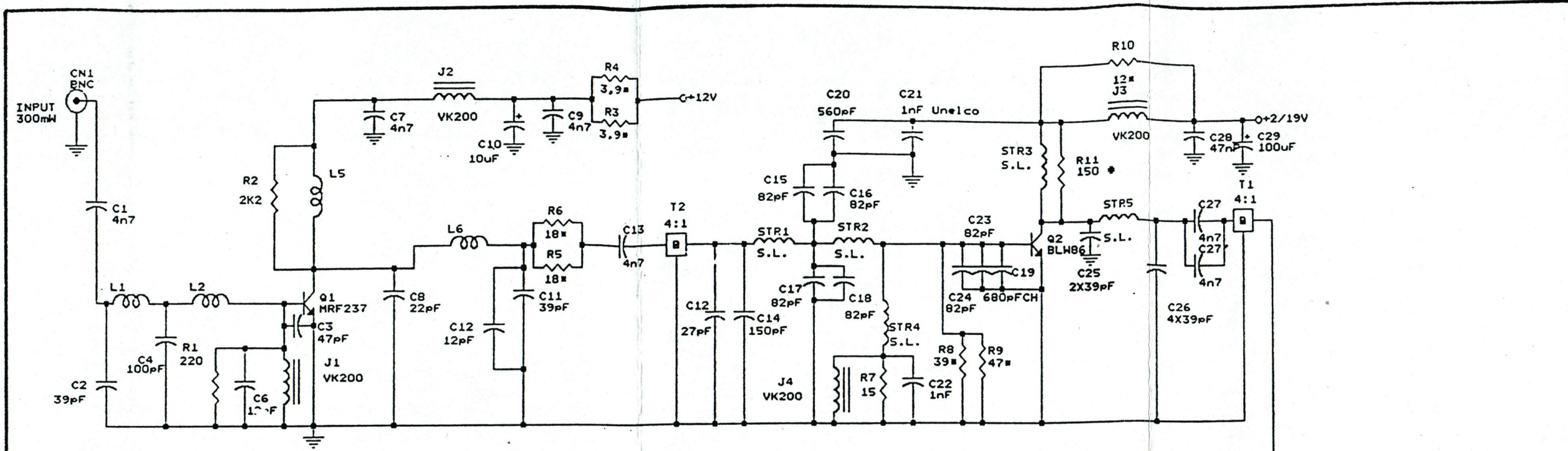

Q1 GROUNDED EMITTER T0-39 PACKAGE

S.T = MICROSTRIP

T1 = T2 = RF TRANSFORMER 4:1 RATIO

L1 = 3sp dia 6mm L1, L2, L5, L6 : smalto 0.8mm

L2 = 2sp dia 5mm

L5 = 6sp dia 6mm

L6 = 2sp dia 7mm

L8 = 5sp dia 6mm L8, L9 : argento 1mm

L9 = 4sp dia 6mm

R \* = 1/2 W

R \* = 2 W

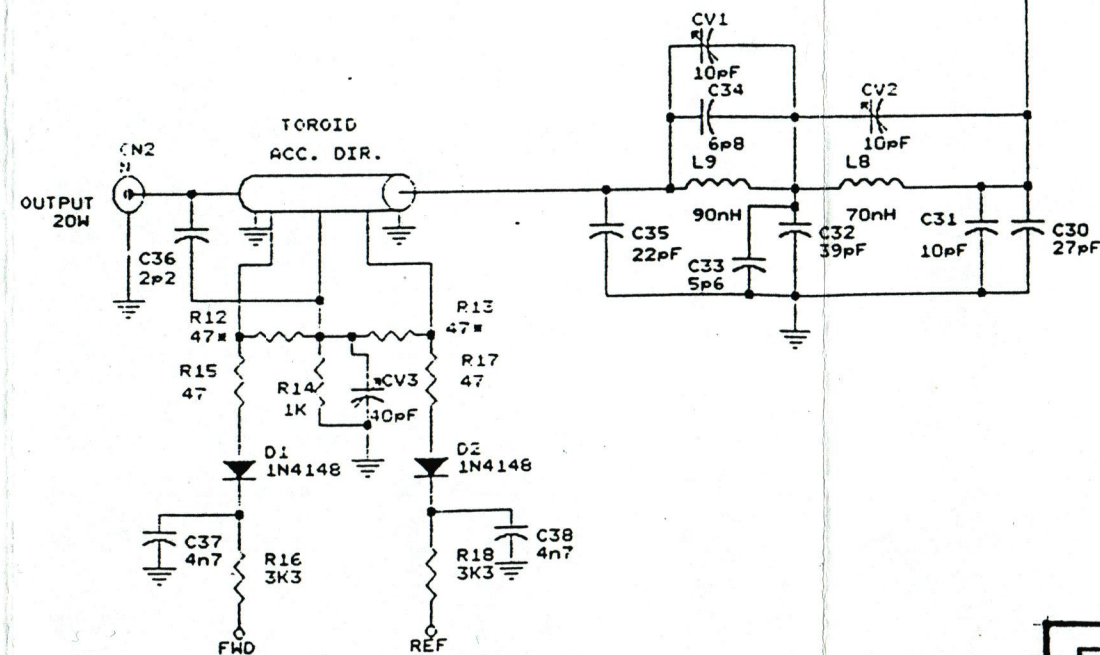

ENERGY ONIX		
HUDSON, N.Y.		
SST 30 AMPLIFIER		
G T J	I-09-95	S218

If You Didn't Get This From My Site,  
Then It Was Stolen From...  
[www.SteamPoweredRadio.Com](http://www.SteamPoweredRadio.Com)

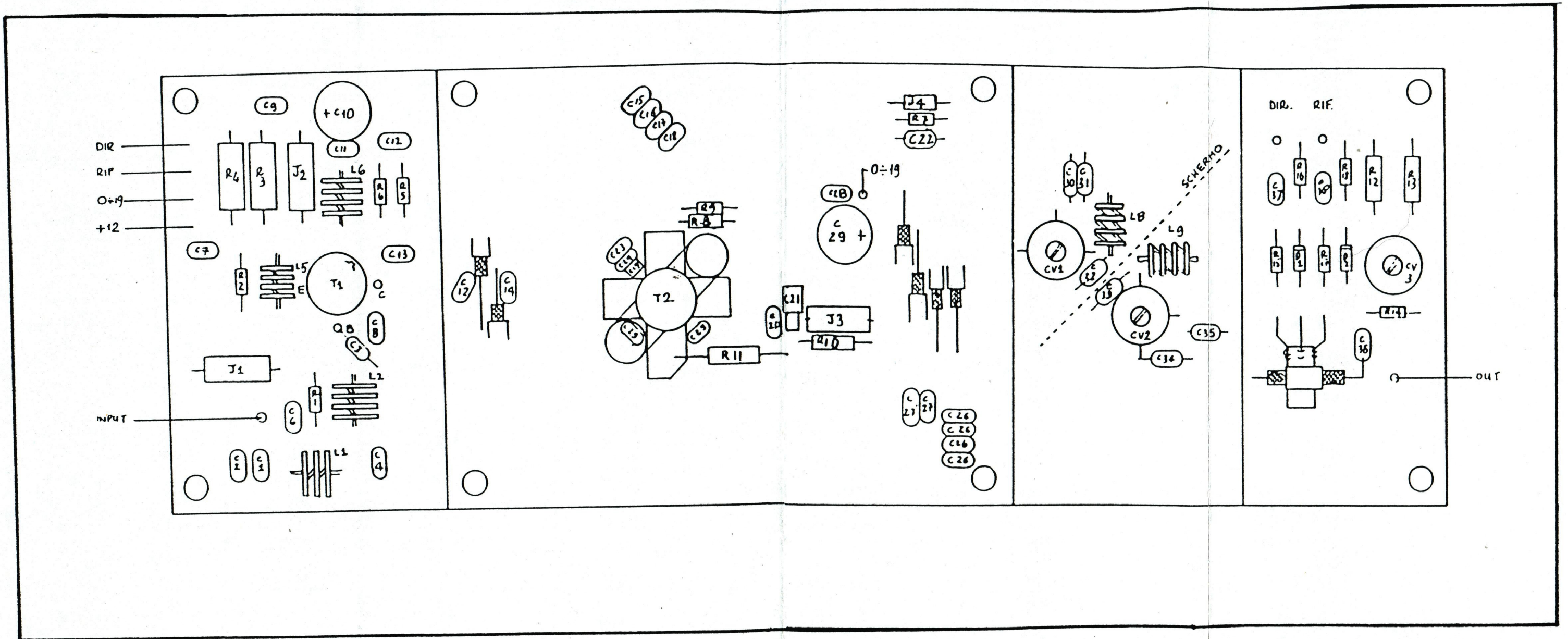

If You Didn't Get This From My Site,  
Then It Was Stolen From...  
[www.SteamPoweredRadio.Com](http://www.SteamPoweredRadio.Com)

<b>ENERGY ONIX</b>		
HUDSON, N.Y.		
SST 30 POWER AMPLIFIER COMPONENT LAYOUT		
G T J	1-09-95	S219

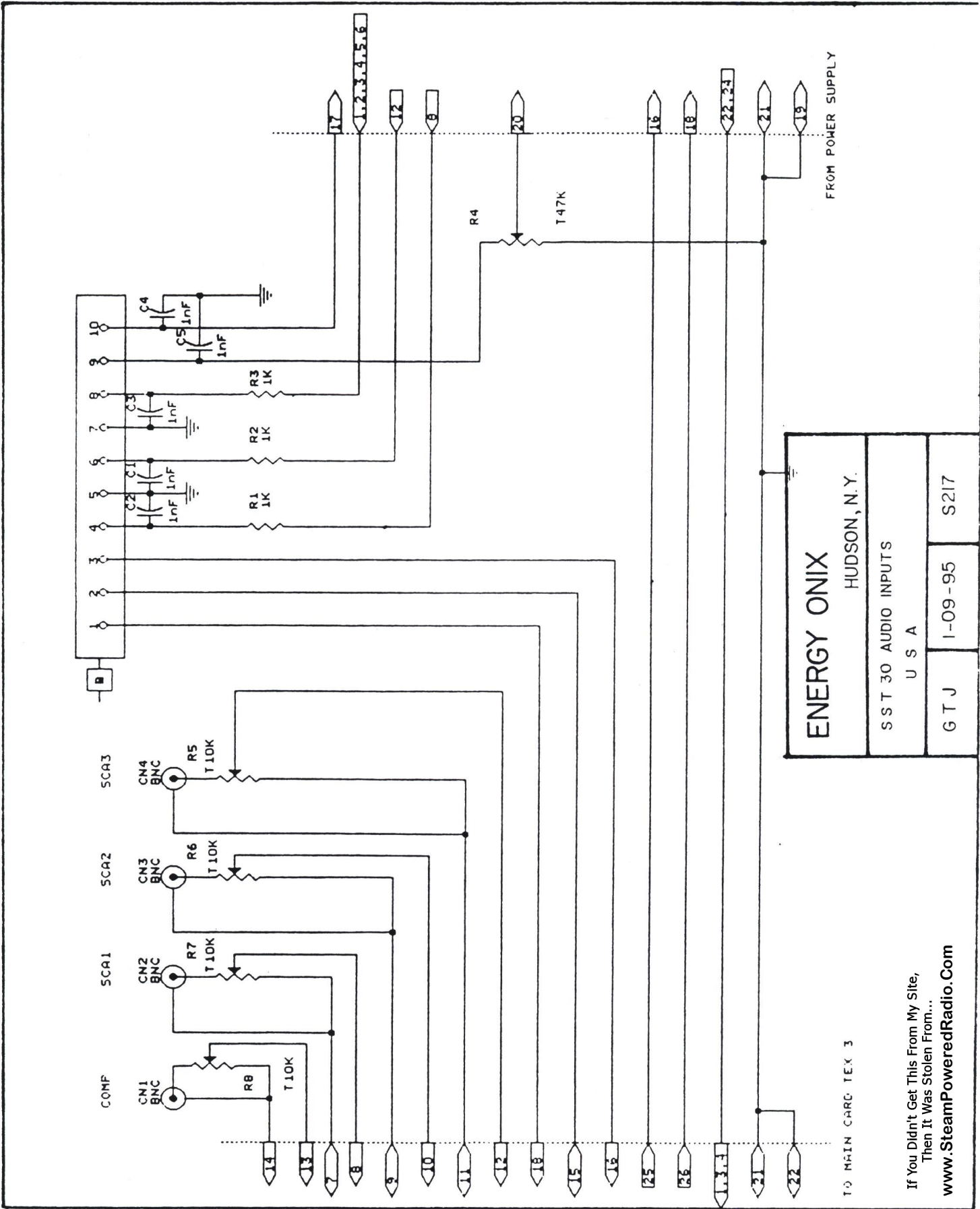

### RECOMMENDED SPARE PARTS SST-30

DIODE VARICAP.....	MV209.....	(1) EACH
DIODE ZENER.....	24 VOLT.....	(1) EACH
DIODE ZENER.....	5.6 VOLT.....	(1) EACH
DIODE ZENER.....	6.8 VOLT.....	(1) EACH
DIODE.....	HP2800.....	(1) EACH
DIODE.....	IN4004.....	(1) EACH
DIODE.....	IN4148.....	(1) EACH
DIODE BRIDGE.....	26MB10A.....	(1) EACH
FUSE.....	2 AMP.....	(1) BOX
FUSE.....	4 AMP.....	(1) BOX
IC.....	LM723.....	(1) EACH
IC.....	LM358N.....	(1) EACH
IC.....	LM7815CT.....	(1) EACH
IC.....	TL074.....	(1) EACH
IC.....	TL082.....	(1) EACH
IC.....	LM7805.....	(1) EACH
IC.....	78L08.....	(1) EACH
IC.....	LM7812CSP.....	(1) EACH
IC.....	74196.....	(1) EACH
IC.....	7400.....	(1) EACH
IC.....	74121.....	(1) EACH
IC.....	74LS02.....	(1) EACH
IC.....	74LS190.....	(1) EACH
IC.....	SP8680.....	(1) EACH
IC.....	CD4046.....	(1) EACH
IC.....	CD4520.....	(1) EACH
IC.....	CD4518.....	(1) EACH
TRANSISTOR.....	J310.....	(1) EACH
TRANSISTOR.....	2N918.....	(1) EACH
TRANSISTOR.....	BC237.....	(1) EACH
TRANSISTOR.....	BCY59.....	(1) EACH
TRANSISTOR.....	2N3866.....	(1) EACH
TRANSISTOR.....	BFR96.....	(1) EACH
TRANSISTOR.....	BF245.....	(1) EACH
TRANSISTOR.....	MJ3001.....	(1) EACH
TRANSISTOR.....	MRF237.....	(1) EACH
TRANSISTOR.....	BLW86.....	(1) EACH

**ENERGY ONIX**  
 HUDSON, N.Y.  
 SST 30 MAIN BOARD  
 COMPONENT LAYOUT  
 G T J 1-09-95 S220

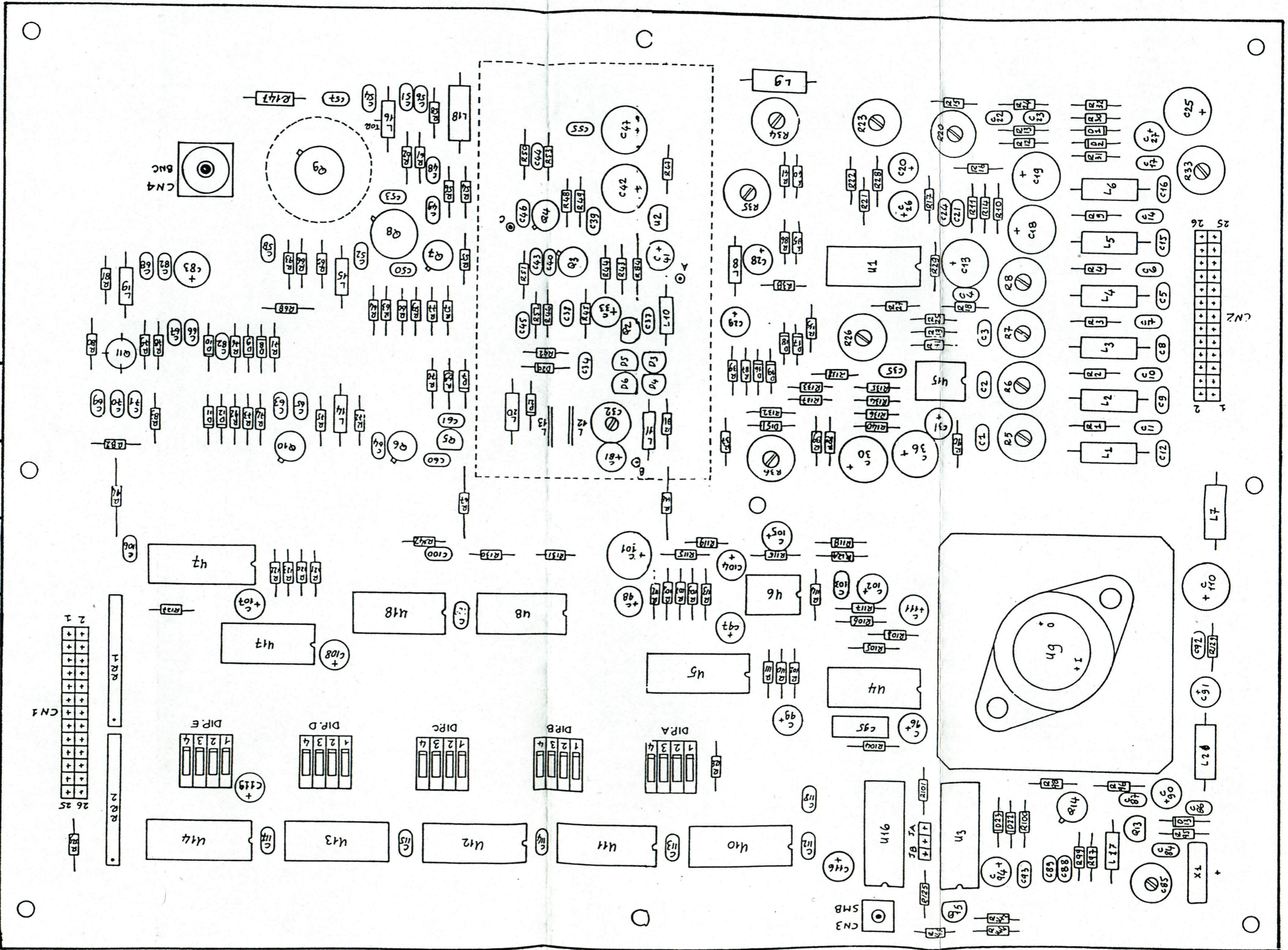

# Warranty

Seller guarantees at his option to either replace or repair any product or part found to be defective in material or workmanship under normal use within one (1) year from date of shipment, with the exception of tubes or moving parts (blowers) which will carry the original manufacturer's warranty only. Seller's obligation is limited to replacement and repair of such defective product or part, if delivered, transportation prepaid to seller's factory within thirty (30) days after return is authorized. Repaired or replacement parts will be sent freight collect.

This warranty is in lieu of all other warranties, expressed or implied, and there is specifically no warranty of merchantability of fitness for a particular use, purpose, or otherwise, unless expressly set forth to the contrary herein and no waiver, alteration or modification herein shall be valid unless in writing signed by the executive officer of seller. There is no warranty on merchandise or equipment which has been subjected to abuse, misuse, neglect, accident, improper installation, or application, negligence in use, storage, transportation or handling; nor is there any warranty as to merchandise which has been repaired or altered outside seller's factory.