

Radio and TV
BROADCASTERS'
CATALOG
of

*Eimac
Tubes*

If You Didn't Get This From My Site,
Then It Was Stolen From...
www.SteamPoweredRadio.Com



Eimac

EITEL-McCULLOUGH, INC.

INFORMATION

AS IT APPEARS
IN THIS CATALOG

IMPORTANT

EIMAC "EXTRAS"

APPLICATION ENGINEERING—As well as being available for consultation the Eimac Application Engineering Department provides information about tube operating techniques, tube data and application bulletins in order to keep you up to date with the latest in electron power tube development.

FIELD ENGINEERING—On the following page is a list of Eimac field engineers who operate out of offices in many major cities of the United States. These men will help you personally with problems of technique, experimental work, etc. Engineers from the Eitel-McCullough, Inc., plant in San Bruno are also available for field consultation throughout the country. As Eimac tubes are universally adopted the same services extend to many countries overseas through the Eimac export division.

Field Engineers

Dealers

Price List

Tube Type Numbering System

Application Bulletin No. 5

4-65A Radial-Beam Power Tetrode

4-125A Radial-Beam Power Tetrode

4-250A Radial-Beam Power Tetrode

4-400A Radial-Beam Power Tetrode

4-1000A Radial-Beam Power Tetrode

4W20,000A Radial-Beam Power Tetrode

4X150A Radial-Beam Power Tetrode

4X150G Radial-Beam Power Tetrode

4X500A Radial-Beam Power Tetrode

4E27A/5-125B Radial-Beam Power Pentode

2C39A Power Triode

3X2500A3 Power Triode

3X2500F3 Power Triode

3X3000A1 Power Triode

3K20,000LK Power Klystron

866A Mercury Vapor Rectifier

872A Mercury Vapor Rectifier

Vacuum Capacitors

Variable Vacuum Capacitors

Finger Stock

HR Connectors

Application Bulletin No. 8

Quick Reference Catalog

EITEL-McCULLOUGH, INC.
SAN BRUNO, CALIFORNIA

**Eimac
Field
Engineers**

Serving eight territories throughout the United States are top qualified men well equipped for electronic factory-field liaison. A phone call or letter to the Eimac field engineer covering your area will bring immediate engineering assistance or information on deliveries and prices. These men are in daily communication with the Eimac factories and have up-to-the-minute information available at their finger tips.

▶ **HERB BECKER**
1140 Crenshaw Blvd.
Los Angeles 19, California
Phone: Webster 1-1257

▶ **DAVE M. LEE CO.**
2517 Second Ave.
Seattle 1, Washington
Phone: Main 5512

W. CLIF McLOUD & CO.
5528 East Colfax Ave.
Denver 7, Colorado
Phone: Fremont 3067

CLYDE H. SCHRYVER SALES CO.
4550 Main St., Room 224
Kansas City 5, Missouri
Phone: Westport 4660

▶ **J. E. JOYNER, JR.**
1706 South Gordon St., S. W.
P. O. Box 341, Station A
Atlanta, Georgia
Phone: Amhurst 1101

▶ **ROYAL J. HIGGINS CO.**
10105 South Western Ave.
Chicago 43, Illinois
Phone: Cedarcrest 3-7388

▶ **ADOLPH SCHWARTZ**
One Exchange Place, Room 919
Jersey City, New Jersey
Phone: Delaware 3-2424, 3-2425

TIM COAKLEY SALES OFFICE
11 Beacon St.
Boston 8, Massachusetts
Phone: Capitol 7-0050

Export Agents
FRAZAR & HANSEN, LTD.
301 Clay St.
San Francisco, California
Phone: Exbrook 2-5112

For information concerning your electronic problems or needs solicit the services of these men without any obligation.

SEE REVERSE SIDE FOR SECTIONAL MAP

Effective 6-5-53

▶ Indicates change from sheet dated 12-1-50

Printed in U.S.A 2-70638

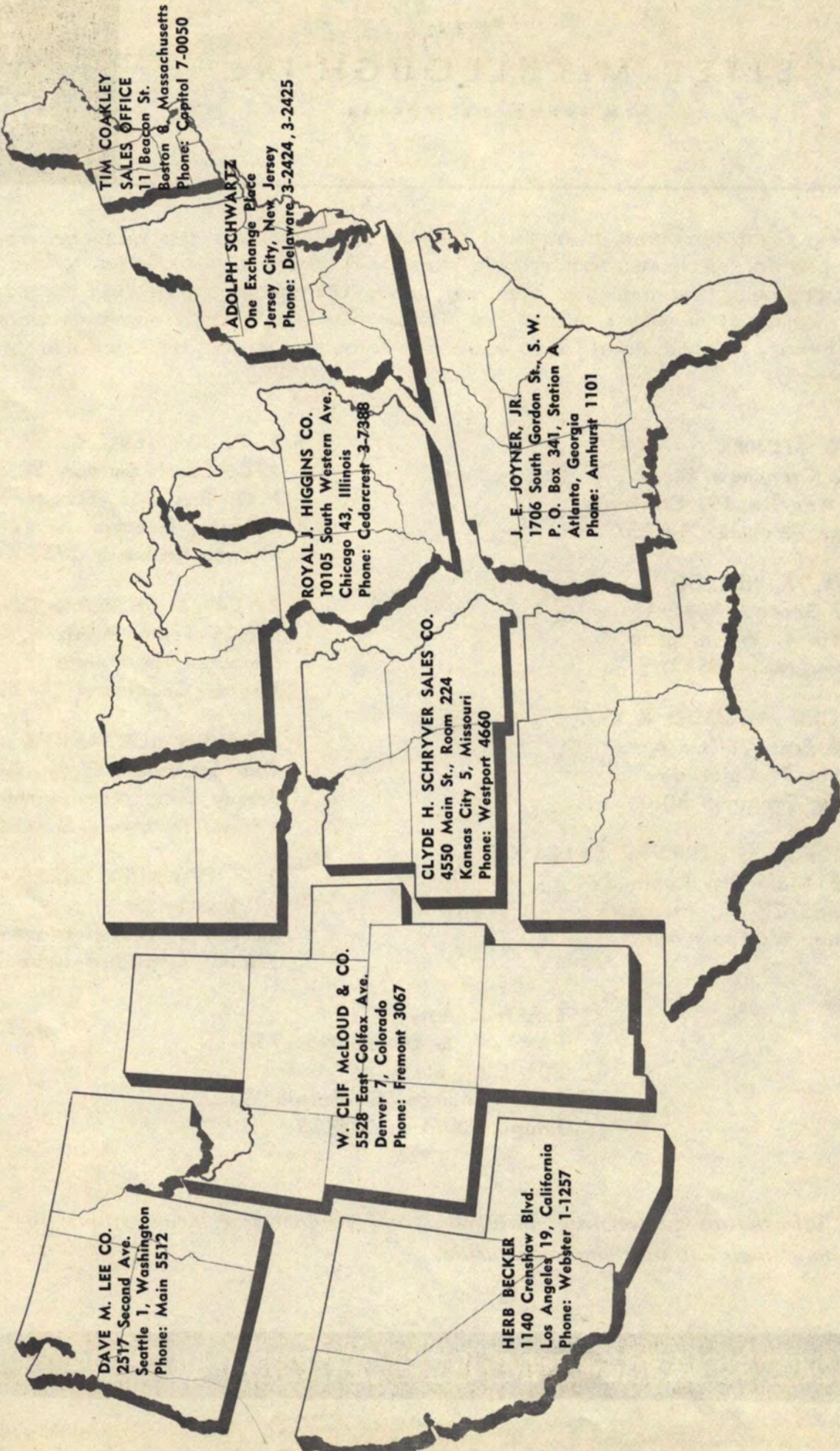

DAVE M. LEE CO.
2517 Second Ave.
Seattle 1, Washington
Phone: Main 5512

W. CLIF McLOUD & CO.
5528 East Colfax Ave.
Denver 7, Colorado
Phone: Fremont 3067

HERB BECKER
1140 Crenshaw Blvd.
Los Angeles 19, California
Phone: Webster 1-1257

TIM COAKLEY
SALES OFFICE
11 Beacon St.
Boston 8, Massachusetts
Phone: Capitol 7-0050

ADOLPH SCHWARTZ
One Exchange Place
Jersey City, New Jersey
Phone: Delaware 3-2424, 3-2425

ROYAL J. HIGGINS CO.
10105 South Western Ave.
Chicago 43, Illinois
Phone: Cedarcrest-3-7388

CLYDE H. SCHRIVER SALES CO.
4550 Main St., Room 224
Kansas City 5, Missouri
Phone: Westport 4660

J. E. JOYNER, JR.
1706 South Gordon St., S. W.
P. O. Box 341, Station A
Atlanta, Georgia
Phone: Amhurst 1101

Export Agents: FRAZAR & HANSEN, 301 Clay Street, SAN FRANCISCO, CALIF. Phone: EXbrook 2-5112

AN EIMAC DEALER IS NEAR YOU

For Your Assurance to Obtain the Most Modern, Guaranteed Eimac Tubes—Purchase Only from These Authorized Distributors

ALASKA

Anchorage

Alaska Radio Supply, Inc.
Box 2279
Yukon Radio Supply, Inc.
Box 406

Fairbanks

Yukon Radio Supply, Inc.
655 - 6th Ave.
P. O. Box 1385

Juneau

Alaska Radio Supply, Inc.
Box 2538

ALABAMA

Birmingham

Ack Radio Supply Co.
2205 - 3rd Ave. North
James W. Clary Co.
1713 - 2nd Ave. South
Forbes Distributing Co., Inc.
2600 - 3rd Ave. South

Mobile

Harris Supply Co.
10 North Water St.
P. O. Box 1009

Montgomery

Nolin-McInnis, Inc.
205 Commerce St.
P. O. Box 2229
Southeastern Radio Parts Co.
210 North Court St.

ARIZONA

Phoenix

Radio Parts of Arizona
214 South 11th Ave.
Radio Specialties & Appliance Corp.
305 E. Roosevelt
Western Radio & Engineering Co.
1915 East Washington St.

Tucson

Elliott Electronics, Inc.
418 North 4th Ave.
P. O. Box 5081

ARKANSAS

Blytheville

Blytheville Radio Supply
112 South First St.

Ft. Smith

Wise Radio Supply
1001 Towson Ave.

Little Rock

Carlton Wholesale Radio, Inc.
109 West 9th St.
P. O. Box 828
Southern Radio Supply
1419 Main St.
David White Radio Supply Co.
1222 Main St.

Texarcana

Lavender Radio Supply Co., Inc.
520 East 4th

CALIFORNIA

Bakersfield

Valley Radio Supply
716 Baker St.

Burbank

Fred S. Dean Co.
919 North Victory Blvd.
Valley Electronic Supply Co.
1302 W. Magnolia Blvd.

Fresno

Jack C. Arbuclie
2330 Kern Ave.

Glendale

Hogerty Radio Supply
6826 San Fernando Road

Los Angeles

Federated Purchaser, Inc.
911 South Grand Ave.
Henry Radio
11240 West Olympic
Kierulff Electronics, Inc.
820 West Olympic Blvd.

Radio Products Sales, Inc.
1501 South Hill St.

Radio Specialties Co.
1956 So. Figueroa St.
Radio Television Supply Co.
341 West 18th St.

Shelley Radio Co.
2008 Westwood Blvd.

Long Beach

Fred S. Dean Co.
969 American Ave.
Larry Lynde Electronics
1526 East 4th St.
Scott Radio Supply, Inc.
266 Alamitos Ave.

Maywood

Kierulff & Company
6058 Walker Ave.

Oakland

W. D. Brill Co.
198 - 10th St.
Electric Supply Co.
140 - 11th St.

Palo Alto

Zack Radio Supply Co.
225 Hamilton Ave.

Pasadena

Daw Radio Supply Co.
1759 E. Colorado St.
Electronic Supply Corp.
2615 East Foothill Blvd.

Sacramento

E. M. Kemp Co.
1115 "R" St.
Sacramento Electric Supply Co.
1219 "S" St.

San Bernardino

Kierulff & Company
1123 W. Base Line at "L" St.

San Diego

Electronic Equipment Distributors
1228 - 2nd Ave.
Shanks & Wright
2045 Kettner St.
Western Radio & Television Supply Co.
1415 India St.

San Francisco

San Francisco Radio Supply Co.
1284 Market St.
Zack Radio & Television
1426 Market St.

San Jose

Frank Quement, Inc.
161 W. San Fernando St.

Santa Ana

Radio & Television Equipment Co.
207 Oak St.

Santa Barbara

Channel Radio Supply Co.
523 Anacapa St.

Stockton

B. J. DeJannatt Wholesale Co.
515 N. Hunter St.

COLORADO

Colorado Springs

Murray Radio Co.
9 East Vermijo

Denver

Inter-State Radio & Supply Co.
1639 Tremont Place
Radio Products Sales Co.
1237 - 16th St.
L. B. Walker Radio Co.
854 Broadway

Grand Junction

Radio & Electronic Supply Co.
511 Ute

Pueblo

L. B. Walker Radio Co.
218 W. 8th St.

CONNECTICUT

Bridgeport

Hatry of Bridgeport, Inc.
1700 Main St.

Hartford

Hatry of Hartford, Inc.
203 Ann St.
R. G. Sceli Co.
1249 Main St.

New Britain

United Radio Supply Co.
47-53 East Main St.

New Haven

Thomas H. Brown Co.
15-25 Whiting St.
Congress Radio Co.
207 Congress Ave.
Dale-Connecticut, Inc.
140 Ferry St.
Hatry of New Haven, Inc.
77 Broadway

New London

Aikins Electronic Supply Co.
428 Bank St.

Stamford

Hatry of Stamford, Inc.
97 Main St.

Waterbury

The Bond Radio Supply
439 W. Main St.
Hatry of Waterbury, Inc.
89 Cherry St.

DELAWARE

Wilmington

Almo Radio Co.
Cor. 6th and Orange St.
Radio Electric Service Co.
3rd and Tottnall Sts.

FLORIDA

Ft. Lauderdale

Goddard Distributors
2113-15 South Andrews Ave.

Jacksonville

Kinkade Radio Supply
1402 Laura St.
Southeast Audio Company
930 W. Adams St.

Lakeland

Radio Accessories Co.
1050 South Florida Ave.

Miami

Electronic Supply Co.
61 N.E. 9th St.
Herman Radio Supply Co.
1365 N.W. 23rd St.
Thurow Distributors, Inc.
2207 N.E. 2nd Ave.

Orlando

Hammond-Adams, Inc.
9 South Terry St.

Pensacola

Grice Radio & Electronic Supplies
360 E. Wright St.

St. Petersburg

Cooper Radio Co.
648 Second Ave. So.

Tallahassee

Thurow Distributors, Inc.
739 North Monroe

Tampa

Kinkade Radio Supply
1707 Grand Central Ave.
Radio Accessories Co.
137-9 So. Franklin St.
Thurow Distributors, Inc.
134-136 South Tampa St.

West Palm Beach

Goddard Distributors, Inc.
1309 North Dixie

GEORGIA

Albany

Specialty Distributing Co.
104 Pine Ave.

Atlanta

Specialty Distributing Co.
425 Peachtree St. N.E.
Southeastern Radio Parts Co.
400 W. Peachtree St.
The Yancey Company, Inc.
1500 Northside Drive N.W.

Augusta

Specialty Distributing Co.
644 Reynolds St.

Columbus

Radio Sales & Service Co.
1326 First Ave.

Macon

Specialty Distributing Co.
539 Arch St.

Savannah

Specialty Distributing Co.
411 E. Broughton St.
Southeastern Radio Parts Co.
38 Montgomery St.

HAWAII

Honolulu, T. H.

Precision Radio Co.
1372-74 So. King St.
Radio Wholesale & Supply Co.
P. O. Box 3768

IDAHO

Boise

Craddock's Radio Supply
1522 State St.
Kopke Electronics Co.
119 Peasley St.

Idaho Falls

Schwendiman's Wholesale Distributors
380 E. Street

ILLINOIS

Belleville

Lurtz Electric Co.
210 North Illinois St.

Chicago

Allied Radio Corp.
833 W. Jackson Blvd.
Chicago Radio Apparatus Co., Inc.
415 South Dearborn St.
Green Mill Radio Supply
145 West 111th St.
Lukko Sales Corp.
5024 Irving Park Rd.
Newark Electric Co.
223 West Madison St.
Star Electronic Distributors, Inc.
7736 South Halsted St.
Walker-Jimieson, Inc.
311 South Western Ave.

Dectatur

York Radio Supply Corp.
801 North Broadway

Elgin

Fox Electric Supply Co.
67-69 North State St.

Peoria

Klaus Radio & Electric Co.
707 Main St.

Quincy

Cooper Supply Co.
935 Main St.

Rockford

H & H Electronic Supply, Inc.
510 Kishwaukee St.
Art A. Johnson Sales & Service
117 Charles St.
Mid-West Associated Distributors
506 Walnut St.

Rock Island

Tri-City Radio Supply, Inc.
1919 - 4th Ave.

EIMAC TUBES ARE THE COUNTERSIGN OF DEPENDABILITY IN ANY ELECTRONIC EQUIPMENT

Springfield

Harold Bruce
120 North 1st St.
Wilson Supply Co.
108 W. Jefferson St.

INDIANA

Anderson

Seyberts Radio Supply
1331 Main St.

Angola

Lakeland Radio Supply Co.
South West and West Pleasant Sts.

Evansville

Costrup's
1014 West Franklin St.
Ohio Valley Sound Service
11 N.W. Riverside Drive
Wesco Radio Parts
428-430 Pennsylvania St.

Fort Wayne

Ft. Wayne Electronics Supply, Inc.
223 East Main St.
Pemberton Laboratories
236 East Columbia at Barr St.
Warren Radio Co.
1716 South Harrison St.

Indianapolis

Graham Electronics Supply, Inc.
102 S. Pennsylvania St.
Meunier Radio Supply Co.
524 North Illinois
Radio Distributing Co.
1013 North Capital Ave.

Lafayette

Holmes Radio Supply Co., Inc.
217 Main St.

Muncie

Radio Supply of Muncie, Inc.
305 North Madison
Standard Radio Parts Co., Inc.
718 South Walnut

Peru

Clingaman Radio
814 West Main St.

Richmond

Radio & Television Distributing Co.
717 South 5th St.

South Bend

Colfax Co., Inc.
802 South Main St.
Radio Distributing Co.
Monroe and Carroll Sts.

Terre Haute

Archer & Evinger
1216 Wabash Ave.
Terre Haute Radio
501 Ohio St.

IOWA

Cedar Rapids

Gifford Brown, Inc.
106-108 First St. S.W.

Council Bluffs

World Radio Laboratories, Inc.
744 West Broadway

Davenport

Tri-City Radio Supply, Inc.
320 East 4th St.

Des Moines

Gifford Brown, Inc.
1216 Grand Ave.
Radio Trade Supply Co.
1224 Grand Ave.

Dubuque

Boe Distributing Co.
498 North Grandview Ave.

Sioux City

Dukes Radio Co.
209 - 6th St.
Power City Radio Co.
408 Jones St.

Waterloo

Farnsworth Radio & Television
623 Jefferson St.
Ray-Mac Radio Supply Co.
200 Ballou St.

KANSAS

Pittsburg

Pittsburg Radio Supply
212 South Broadway

Salina

Western Dist. Radio & Supply Co.
227 North Santa Fe

Topeka

Acme Radio Supply
412 E. 10th St.
John A. Costelow Co., Inc.
125 Kansas Ave.
The Overton Electric Co., Inc.
522 Jackson St.

Wichita

Amateur Radio Equipment Co.
1203 East Douglas
Interstate Electronic Supply Corp.
230 Ida, P. O. Box 2018
Radio Supply Co.
1125-27 East Douglas

KENTUCKY

Lexington

Electronic Distributors
134 West 3rd St.
Kentucky Radio Supply Co.
376 East Main St.
Radio Equipment Co.
480 Skain St.

Louisville

P. I. Burks & Co., Inc.
911 West Broadway
Universal Radio Supply Co.
533 South 7th St.

LOUISIANA

Alexandria

Central Radio Supply Co.
509 Monroe St.

Baton Rouge

Electronic Supply Co.
1751-53 North 21st St.

Lafayette

Ralph's Radio Electronic Supply
300 1/2 Cameron St.

Lake Charles

Wholesale Radio Equipment Co.
230 Bilboa St.

Monroe

Hale & McNeil
421 Walnut St.

New Orleans

Columbia Radio & Supply Co.
3940 - 3rd St.

Electronic Parts Corp.
205-207 North Broad

Radio Parts, Inc.
807 Howard Ave.

Shuler Supply Co.
415 Dryades St.

Shreveport

Interstate Electric Co. of Shreveport, Inc.
630 Spring St.
Koelemay Sales Co.
220 Crockett St.

MAINE

Auburn

Radio Supply Co., Inc.
26 Cross St.

Bangor

Radio Service Laboratory
76 Exchange St.

Portland

Maine Electronic Supply Corp.
148 Anderson St.
Radio Service Laboratory
1004 Congress St.

MARYLAND

Baltimore

Henry O. Berman Co., Inc.
12 East Lombard St.
Kann-Ellert Electronics, Inc.
9 South Howard St.
Radio Electric Service Co.
5 North Howard St.
Wholesale Radio Parts Co., Inc.
3311 West Baltimore St.

Cumberland

Zimmerland Wholesalers
162 Bedford St.

Hagerstown

114 E. Washington St.

Salisbury

Almo Radio Co.
219 Highland Ave.

MASSACHUSETTS

Boston

DeMambro Radio Supply Co.
1111 Commonwealth Ave.
General Electric Supply Corp.
145 North Beacon
Hatry & Young of Mass., Inc.
42-44 Cornhill
The Louis M. Herman Co.
885 Boylston St.
A. W. Mayer Co.
895 Boylston St.
Radio Shack Corp.
167 Washington St.
Radio Wire Television, Inc.
110 Federal St.

Brockton

Ware Radio Supply Co.
913 Center St.

Cambridge

The Eastern Co.
620 Memorial Drive
Electrical Supply Corp.
1739 Massachusetts Ave.

Fitchburg

Hatry & Young of Fitchburg, Inc.
390 Water St.

Holyoke

Oakes Electrical Supply Co.
271 Appleton St.
Springfield Radio Co.
93 High St.

Lawrence

Hatry & Young of Lawrence, Inc.
262 Lowell St.

New Bedford

C. E. Beckman Co.
11 Commercial St.

Pittsfield

Pittsfield Radio Co.
41 West St.

Springfield

T. F. Cushing
349 Worthington St.
Hatry & Young of Springfield, Inc.
169 Spring St.
Riga Electrical Corp.
376 Worthington St.
Soundco Electronic Supply Co.
147 Dwight St.
Springfield Radio Co.
405 Dwight St.
Westinghouse Electric Supply Co.
46 Hampden St.

Worcester

DeMambro Radio Supply Co., Inc.
222 Summer St.
Radio Electronic Sales Co.
52 Chandler St.
Radio Maintenance Supply Co.
80 Thomas St.

MICHIGAN

Ann Arbor

Purchase Radio & Camera Shop
605 Church St.

Wedemeyer Electronic Supply Co.
215 North 4th Ave.

Battle Creek

Electronic Supply Corp.
94 Hamblin Ave.

Bay City

Kinde Distributing Co.
504 Washington Ave.

Detroit

M. N. Duffy & Co.
2040 Grand River Ave. W.
Radio Electronic Supply Co.
1112 West Warren Ave.
Radio Specialties Co.
456 Charlotte Ave.

Flint

Shand Radio Specialties
203 West Kearsley St.

Grand Rapids

Radio Electronic Supply Co.
505 Jefferson Ave. S.E.

Jackson

Fulton Radio Supply Co.
265 West Cortland St.

Kalamazoo

Electronic Supply Corp.
906 East Michigan Ave.
Ralph M. Ralston Co.
201 North Park St.

Lansing

Wedemeyer Electronic Supply Co.
2005 East Michigan Ave.

Larum

Northwest Radio

Muskegon

Fitzpatrick Electric Supply Co.
444 Irwin Ave., Cor. Wood
Bell-Lourim Electronics, Inc.
1839 Peck St.

Pontiac

Electronic Supply Co.
248 East Pike St.

MINNESOTA

Duluth

Lew Bonn Company
228 East Superior St.
Northwest Radio
123 East 1st St.

Minneapolis

Lew Bonn Company
1211 LaSalle Ave.
Electronic Center, Inc.
107 - 3rd Ave. No.
Northwest Radio & Electronic Supply Co.
52 South 12th St.
Stark Radio Supply Co.
71 South 12th St.

St. Paul

Lew Bonn Co.
141-147 West 7th St.
Hall Electric
566 North Robert St.

MISSISSIPPI

Jackson

Swan Distributing Co. Inc.
342 N. Gallatin St. - P. O. Box 3201

MISSOURI

Butler

Henry Radio
211 North Main St.

Cape Girardeau

Suedekum Electronic Supply Co.
902 South Sprigg St. - P. O. Box 221

Joplin

4-State Radio & Supply Co.
201 Main St.

Kansas City

Burstein-Applebee Company
1012-14 McGee St.
Continental Electric Co.
1321 West 13th St.
Electro-Crafts
1305 Swift, North
Radiolab
1612 Grand Ave.

Poplar Bluff

Tri-State Radio & Supply Co.
118 Bartlett St.

St. Joseph

Acme Radio Supply
110 North 9th St.
St. Joseph Radio & Supply Co.
922-24 Francis St.

St. Louis

Ar-Ka Engineering, Inc.
1319 South Vandeventer
Walter Ashe Radio Co.
1125 Pine St.
Interstate Supply Co.
26 South 10th St.
Radonics
5040 Easton Ave.
Van Sickle Radio
1113 Pine St.

Springfield

Harry Reed Radio & Supply Co.
805 Boonville Ave.

MONTANA

Billings

Electronic Supply Co.
214 - 11th St. West

Butte

Smith Supply Co.
425 So. Arizona St.

Great Falls

Geo. Lindgren Co.
P. O. Box 966

Missoula

Northwest Distributors
509 South Higgins Ave.

NEBRASKA

Lincoln

Hicks Radio Co.
1422 "O" St.
Leuck Radio Supply
243 South 11th St.

Omaha

J. B. Distributing Co.
1616 Cass St.
Omaha Appliance Co.
18th and St. Mary's
Radio Equipment Co.
2852 Douglas St.

Scottsbluff

Joaquim Radio Supply, Inc.
1913 Broadway - P. O. Box 67

NEVADA

Reno

Ed. Heim Radio & Electronics
1185 Wells Ave.

NEW HAMPSHIRE

Concord

Evans Radio
P. O. Box 312

Dover

American Radio Corp.
510 Central Ave.

Manchester

DeMambro Radio Supply Co.
1308 Elm St.
Radio Service Laboratory
670 Chestnut St.

NEW JERSEY

Atlantic City

Almo Radio Co.
4401 Ventnor Ave

Radio Electric Service Co.
406 North Albany

Camden

Almo Radio Co.
1133-35-37 Haddon Ave.
Radio Electric Service of N. J., Inc.
513-515 Cooper St.

Newark

Continental Sales Co. Inc.
Bloomfield Ave. at North 11th St.
Federated Purchaser Corp.
114 Hudson St. at Central Ave.
Aaron Lippman & Co.
99-107 Newark St.
Radio Wire-Television, Inc.
24 Central Ave.
Westinghouse Electric Supply Co.
528 Ferry St.

New Brunswick

William Radio Supply Co.
1861 Woodbridge Ave., Route 43

Trenton

Allen and Hurley
25 South Warren St.

NEW MEXICO

Albuquerque

Radio Equipment Co.
523 East Central Ave.
L. B. Walker Radio Co., Inc.
114 West Granite Ave.

Roswell

Supreme Radio Supply
129 West 2nd St.

Santa Fe

A-1 Communications Supply Co.
110 West Palace Ave.

NEW YORK

Albany

Fort Orange Distributing Co.
904 Broadway
E. E. Taylor Co.
465 Central Ave.

Amsterdam

Adirondak Radio Supply
P. O. Box 88

Binghamton

Federal Radio Sales & Supply Corp.
188 State St.

Brooklyn

Peerless Electronics Distributors Corp.
76 Willoughby St.

Buffalo

Dymac, Inc.
2329 Main St.
Genesee Radio & Parts Company
205 Genesee St.
Radio Equipment Corp.
147 Genesee St.

Cortland

C. A. Winchell Radio Supply Co.
37 Central Ave.

Fredonia

Barker-Higbee, Inc.
27 Water St.

Hempstead

Standard Parts Corp.
277 No. Franklin St.

Ithaca

Stallman of Ithaca, Inc.
123-131 South Tioga St.

Jamaica, L. I.

Harrison Radio Corporation
172-31 Hillside Ave.
Norman Radio Distributors, Inc.
94-29 Merrick Road
Peerless Radio Distributors, Inc.
92-32 Merrick Road

Mount Vernon

Davis Radio Distributing Co.
66 East 3rd St.

New York City

Arrow Electronics Co.
82 Cortlandt St.
Electronics Center Inc.
118 Duane St.
Federated Purchaser
66 Dey St.
Grand Central Radio
124 East 44th St.
Harrison Radio Corp.
225 Greenwich St.
Harvey Radio Co. Inc.
103 West 43rd St.
Hudson Radio & Television Corp.
48 West 38th St.
Hudson Radio & Television Corp.
212 Fulton St.
Life Electronic Sales
345 Broadway
Midway Radio & Television Corp.
60 West 45th St.
Milo Radio & Electronics Corp.
200 Greenwich St.
Radio Wire Television, Inc.
100 - 6th Ave.
Sanford Electronics Corp.
157 Chambers St.
Sun Radio & Electronics Co., Inc.
122-124 Duane St.
Terminal Radio Corp.
85 Cortlandt St.

Rochester

Hunter Electronics
233 East Ave.
Masline Radio & Electronic Equip. Co.
192-196 Clinton Ave., North
Rochester Radio Supply Co.
114 St. Paul St.

Syracuse

W. E. Berndt
655 South Warren St.
Radio Supply Co.
200 Walton St.
Stewart W. Smith, Inc.
325 East Water St.

Utica

Beacon Electronics, Inc.
14 Catherine St.
Voeth Electric Co.
35 Genesee St.

Watertown

Beacon Electronics, Inc.
108 Lincoln Bldg.

White Plains

Westchester Electronic Supply Co.
420 Mamaroneck Ave.

Yonkers

Yonkers Electronic Supply, Inc.
541 Nepperhan Ave.

NORTH CAROLINA

Asheville

Freck Radio & Supply Co.
38 Biltmore Ave.

Charlotte

Dixie Radio Supply Co., Inc.
715 West Morehead
Shaw Distributing Co.
205 West 1st St.
Southern Radio Corp.
1625 West Morehead

Greensboro

Johannesen Electric Co.
312-14 North Eugene St.
Southeastern Radio Supply Co.
404 North Eugene St.

Raleigh

Radio Amateur Center
411 Hillsboro St.
Southeastern Radio Supply Co.
415 Hillsboro St.

Winston-Salem

Dalton Hege Radio Supply Co.
924 West 4th St.

NORTH DAKOTA

Fargo

Bristol Distributing Co.
419 N.P. Ave.
Fargo Radio Service Co.
515 - 3rd Ave. North

OHIO

Akron

Olson Radio Warehouse, Inc.
73 East Mill St.
The Sun Radio Co.
110 East Market St.

Ashtabula

Morrison's Radio Supply
331 Center St.

Canton

Armstrong's Electronic Center
1261 Cleveland Avenue Northwest
Wireless Radio & Television
117 - 12th St., N.E.

Cincinnati

Chambers Electronic Supply Co., Inc.
1667-71 Central Parkway
Herrlinger Distributing Co.
15th and Vine Sts.
Hughes Peters, Inc.
1128 Sycamore St.
The Mytronic Co.
121 West Central Parkway
The Schuster Electric Co.
319-21 East 8th St.
Steinberg's, Inc.
633 Walnut St.
United Radio, Inc.
1314 Vine St.

Cleveland

Northern Ohio Laboratories
2073 West 85th St.
Pioneer Radio Supply Corp.
2115 Prospect Ave.
The Progress Radio Supply Co.
415 Huron Road
Radio & Electronics Part Corp.
3235 Prospect Ave.

Winteradio, Inc.
1468 West 25th St.

Columbus

Hughes-Peters, Inc.
111-17 East Long St.
Thompson Radio Supplies
182 East Long St.

Dayton

Hughes-Peters, Inc.
300 West 5th at Perry
Srepco, Inc.
135 East 2nd St.
Stolts-Friedman Co.
620 South Main St.

East Liverpool

D & R Radio Supply
631 Dresden Ave.

Lima

Lima Radio Parts Co.
600 North Main St.

Springfield

Eberlie's Radio Supply
522 West Main St.
Standard Radio—Springfield, Inc.
119 West Main St.

Stuebenville

D & R Radio Supply
156 South 3rd St.

Toledo

The H & W Auto Accessories Co.
26 North 11th St.
Lifetime Electronics
1501-05 Adams St.
Warren Radio Company
1320 Madison Ave.

Youngstown

Radio Parts Co.
230 Boardman St.

- Ross Radio Company
325 West Federal St.
- OKLAHOMA**
Oklahoma City
Radio Supply, Inc.
724 North Hudson
- Tulsa**
Electronic Supplies
219 East 1st St.
Industrial Electronic Supply, Inc.
1124 East 4th St.
Oil Capital Electronics Corp.
923 East 4th St.
Radio, Inc.
1000 South Main St.
S & S Radio Supply Co.
721 S. Detroit St.
- OREGON**
Eugene
Carlson, Hatton & Hay, Inc.
96 East 10th Ave.
United Radio Supply, Inc.
179 West 8th St.
- Medford**
Verl G. Walker Co.
P. O. Box 1586
- Portland**
Central Distributors
1135 S.W. Washington St.
Fleming & Company
N.W. Broadway at Flanders
Harper-Meggee Co.
1506 N.W. Irving St.
Lou Johnson Co., Inc.
422 N.W. 8th Ave.
Northwest Radio Supply Co.
717 S.W. Ankeny St.
Pacific Stationery Wholesale Radio Dept.
414 S.W. 2nd Ave.
Portland Radio Supply Co.
1300 West Burnside St.
Stubbs Electric Co.
33 N.W. Park Ave.
United Radio Supply, Inc.
22 N.W. 9th Ave.
- Salem**
Lou Johnson Company
1051 South Commercial St.
- PENNSYLVANIA**
Altoona
Hallenbeck's
2221-3-5 Eighth Ave.
- Bethlehem**
Buss Radio Electric Supply
61-63 East Broad St.
- Erie**
J. V. Duncombe Co.
1011 West 8th St.
Warren Radio, Inc.
12th and State Sts.
- Harrisburg**
Radio Distributing Co.
915 South 13th St.
- Philadelphia**
A. C. Radio Supply Co.
1539 West Passyunk Ave.
Almo Radio Co.
509 Arch St.
Almo Radio Co.
6205 Market St.
Almo Radio Co.
412-16 North 6th St.
Consolidated Radio Co.
612 Arch St.
Herbach & Rademan, Inc.
1205 Cuthbert St.
M & H Sporting Goods Co.
512 Market St.
Radio Electric Service Co.
N.W. Cor. 7th and Arch Sts.
Radio Electric Service Co. of Penna., Inc.
3412-14 Germantown Ave.
Albert Steinberg & Company
2520 North Broad St.
Eugene G. Wile
218 South 11th St.
- Pittsburgh**
Cameradio
1121 Penn. Ave.
- M. V. Mansfield Co.
937 Liberty Ave.
Radio Parts Company
6339 Penn. Ave.
Tydings Company
5800 Baum Blvd.
- Reading**
George D. Barbey Co.
2nd and Penn Sts.
- Scranton**
Fred P. Pursell
548-50 Wyoming Ave.
Scranton Radio & Television Supply Co.
519-21 Mulberry St.
- Uniontown**
Zimmerman Wholesalers
55 Morgantown St.
- Wilkes-Barre**
Radio Service Co.
346 South Main St.
- Williamsport**
Williamsport Radio Supply
518 West 3rd St.
- York**
York Radio & Refrigeration Parts
263 West Market St.
- RHODE ISLAND**
Providence
Wm. Dandreta & Co.
129 Regent Ave.
DeMambo Radio Supply Co.
90 Broadway
W. H. Edwards Co.
94 Broadway
- SOUTH CAROLINA**
Charleston
Radio Laboratories
215 King St.
- Columbia**
Dixie Radio Supply Co., Inc.
1700 Laurel St.
Southeastern Radio Parts Co.
1513 Taylor St.
- Greenville**
Dixie Radio Supply Co., Inc.
22 South Richardson St.
- Spartanburg**
McElhenney Co., Inc.
204 St. John St.
- SOUTH DAKOTA**
Aberdeen
Burghardt Radio Supply
P. O. Box 342
- Sioux Falls**
Power City Radio Co.
209 South 1st Ave.
- Watertown**
Burghardt Radio Supply
P. O. Box 41
- TENNESSEE**
Bristol
Roden Electrical Supply Co.
104 East State St.
- Chattanooga**
Specialty Distributing Co.
135 Market St.
- Jackson**
L. K. Rush Company
103 Highland
- Kingsport**
Chemcity Radio & Electric Co.
1019 Bristol Highway
- Knoxville**
Chemcity Radio & Electric Co.
12 Emory Park
Roden Electrical Supply Co.
808 North Central Ave.
- Memphis**
Bluff City Distributing Co.
905 Union Ave.
Lavender Radio Supply Co., Inc.
180 South Cooper St.
W & W Distributing Co.
639 Madison Ave.
- Nashville**
Braid Electric Co.
1100 Demonbreum St.
Electra Distributing Co.
1914 West End Ave.
- TEXAS**
Abilene
R & R Electronic Co.
802-4 Walnut St.
- Amarillo**
R & R Electronic Co.
707 Adams St.
West Texas Radio Supply
1026 West 6th St.
- Austin**
The Hargis Co.
706 West 6th St.
- Beaumont**
Montague Radio Distributing Co.
760 Laurel St.
- Brownsville**
Electronic Equipment & Engineering Co.
1152 East Madison St.
- Corpus Christi**
Electronic Equipment & Engineering Co.
805 South Staples St.
Wicks-DeVilbiss Co.
513-15 South Staples St.
- Dallas**
Crabtree's Wholesale Radio
2608 Ross Ave.
Industrial Electronic Subply, Inc.
134 Leslie St.
Ra-Tel, Inc.
2409 Ross Ave.
Southwest Radio Supply
1820 North Horwood St.
Wilkinson Bros.
P. O. Box 1169
- Denison**
Denison Radio Supply
310 West Woodard St.
- El Paso**
C. C. McNicol
811 North Estrella
Midland Specialty Co.
425 West San Antonio St.
Reeves Radio Supply
720 North Stanton St.
- Fort Worth**
Electronic Equipment Co.
917-19 Florence St.
Ft. Worth Radio Supply Co.
1201 Commerce St.
Scooter's Radio Supply Co.
509 Commerce St.
Bill Sutton's Wholesale Electronics
Commerce at 5th St.
- Houston**
Busacker Electronic Equipment Co.
1721 Waugh Drive
Electronic Parts Co.
3508 Crawford St.
Geophysical Supply Co.
P. O. Box 2214
Robert E. Franklin Co.
1905 Chartres St.
Gulf Coast Electronics
1110 Winbern St.
R. C. & L. Hall, Inc.
1219 Caroline St.
Harrison Equipment Co.
1422 San Jacinto St.
Houston Radio Supply Co., Inc.
Clay at LaBranch
Lenert Company
2213 Congress Ave.
Sterling Radio Products Co.
1616 McKinney Ave.
Straus-Frank Company
4000 Leeland Ave.
- Laredo**
Guarantee Radio Supply Co.
1314 Ilurbide St.
- Lubbock**
R & R Supply Co., Inc.
706 Main St.
- West Texas Radio Supply
1007 Avenue Q
- McAllen**
Rio Radio Supply Co.
P. O. Box 168
- San Angelo**
Gunter Wholesale Co.
606 South Irving St. - P. O. Box 1505
- San Antonio**
Amateur Headquarters & Supply
P. O. Box 5086, Beacon Hill Station
Electronics, Inc.
616 Broadway
Mission Radio, Inc.
P. O. Box 2487
Radio & Television Parts Co.
118-20 Seventh St.
Rio Radio Supply Co.
818 San Pedro
Straus-Frank Company
301 South Flores St.
- Tyler**
Lavender Radio Supply Co.
502 East Oakwood
- Waco**
The Hargis Co., Inc.
1205 Washington Ave.
- Wichita Falls**
Clark & Gose Radio Supply
1203 Indiana Ave.
Mooney Radio Supply Co.
P. O. Box 969
- UTAH**
Ogden
Ballard & Carter Co.
2428 Grant Ave.
- Salt Lake City**
O'Loughlin's Radio Supply Co.
113 East Broadway
Radio Supply Co.
157 Motor Ave.
S. R. Ross, Inc.
1212 South State St.
Standard Supply Co.
531 South State St.
- VIRGINIA**
Bristol
Bristol Radio Supply Corp.
31 Moore St.
- Lynchburg**
Eastern Electric Co.
920 Commerce St.
- Norfolk**
Radio Equipment Co.
821 West 21st St.
Radio Parts Distributing Co.
128 West Olney Road
Radio Supply Co.
711 Granby St.
- Richmond**
The Arnold Company
2810 West Marshall St.
Radio Supply Company
3302 West Broad St.
Wyatt-Cornick, Inc.
Grace at 14th St.
- Roanoke**
H. C. Baker Sales Co., Inc.
19 Franklin Road
- WASHINGTON**
Bellingham
Waitekus Supply Co.
110 Grand Ave.
- Everett**
Pringle Radio Wholesale Co.
2514 Colby Ave.
- Seattle**
Alaska Radio Supply, Inc.
1844 Westlake Ave. North
Electronic Supply Corp.
6305 - 49th Ave. S.W.
Harper-Meggee, Inc.
960 Republican St.
Radio Products Sales Co., Inc.
1214 First Ave.
- Seattle Radio Supply, Inc.
2117 Second Ave.
Western Electronic Supply Co.
717 Dexter Ave.
Westlake Electronic Supply
511 Westlake Ave., North
Herb E. Zobrist Co.
2121 Westlake Ave.
- Spokane**
Columbia Electric & Mfg. Co.
South 123 Wall St.
Harper-Meggee Co.
North 734 Division
Northwest Electronics Co.
North 102 Monroe St.
- Tacoma**
C & G Radio Supply Co.
2502-6 Jefferson Ave.
A. T. Stewart Co.
743 Broadway
- Walla Walla**
Kar Radio & Electric Co.
12th and Pine Sts.
- WASHINGTON, D. C.**
Capitol Radio Wholesalers
2120 - 14th St. N.W.
Electronic Wholesalers Inc.
2345 Sherman Ave. N.W.
General Electric Supply Corp.
705 Edgewood St. N.E.
Kenyan Radio Supply Company
2020 - 14th St. N.W.
Rucker Radio Wholesalers
1312 - 14th St. N.W.
Southern Wholesalers, Inc.
707 Edgewood St. N.E.
Sun Radio
938 "F" St. N.W.
- WEST VIRGINIA**
Charleston
Chemcity Radio & Electric Co.
103 Clendenin St.
- Clarksburg**
Trenton Radio Co.
791 Pike St.
- Huntington**
Electronic Supply, Inc.
422 Eleventh St.
King & Irwin Inc.
316 Eleventh St.
- Morgantown**
Trenton Radio Co.
300 Grant Ave.
- Wheeling**
General Electronics Distributors, Inc.
26 Tenth St.
- WISCONSIN**
Appleton
Appleton Radio Supply Co.
1217 North Richmond St.
Valley Radio Distributors
518 North Appleton St.
- Madison**
Satterfield Radio Supply
326 West Gorham St.
- Marinette**
G. M. Popkey Co.
Main at 9th St.
- Milwaukee**
Central Radio Parts Co.
1723 West Fond du Lac Ave.
Electro-Pliance Distributors, Inc.
2548 West Lisbon Ave.
Radio Parts Co., Inc.
536-38 West State St.
- Wausau**
Radio Service & Supply Co.
615 Third St.
- WYOMING**
Cheyenne
Houge Radio & Supply Co.
2008 Carey Ave.

VACUUM TUBES

TUBE TYPE	PRICE	TUBE TYPE	PRICE
2-01C	\$ 15.25	6C21	\$ 77.00
2-25A	11.00	KY21A	13.25
2-50A	13.75	RX21A	9.00
2-150D	19.25	25T	9.00
2-240A	66.00	35T	10.50
2-2000A	214.50	35TG	16.00
2C39A	34.00	75TH	13.25
3K20,000LA	2,975.00	75TL	13.25
3K20,000LF	2,975.00	100TH	18.25
3K20,000LK	2,975.00	100TL	18.25
3W5000A3	198.00	152TH	28.75
3W5000F3	198.00	152TL	28.75
3W10,000A3	957.00	250R	22.00
3X2500A3	198.00	250TH	33.00
3X2500F3	198.00	250TL	33.00
3X3000A1	198.00	253	20.50
4-65A	20.00	304TH	60.50
4-125A	30.25	304TL	60.50
4-250A	41.25	450TH	77.00
4-400A	60.50	450TL	77.00
4-1000A	132.00	592/3-200A3	30.25
4E27A/5-125B	35.75	750TL	137.50
4PR60A	90.00	866A	2.10
4W20,000A	1,850.00	872A	8.20
4X150A	48.00	1000T	137.50
4X150D	48.00	1500T	220.00
4X150G	54.00	2000T	275.00
4X500A	121.00	8020(100R)	15.00
4X500F	93.50		

VACUUM CAPACITORS

TYPE	PRICE	TYPE	PRICE
VC6-20	\$15.00	VC50-20	\$ 24.25
VC6-32	17.25	VC50-32	27.50
VC12-20	16.50	VVC60-20	66.00
VC12-32	20.00	VVC2-60-20	147.50
VC25-20	20.00	VVC4-60-20	284.00
VC25-32	23.25		

HEAT DISSIPATING CONNECTORS

TYPE	PRICE	TYPE	PRICE
HR-1	\$.60	HR-6	\$.80
HR-2	.60	HR-7	1.60
HR-3	.60	HR-8	1.60
HR-4	.80	HR-9	3.00
HR-5	.80	HR-10	1.60

AIR SYSTEM SOCKETS

TYPE	PRICE
4-400A/4000	\$16.00
4-400A/4001	12.00
4-400A/4006*	6.00
4-1000A/4000	22.50
4-1000A/4001	17.00
4-1000A/4006*	7.50
4X150A/4000	18.00
4X150A/4001	17.50
4X150A/4006*	.60
4X150A/4010	20.15
4X150A/4011	19.70

*Replacement Chimneys

PREFORMED CONTACT FINGER STOCK

	PRICE
17/32" - - - -	\$1.65/ft.
31/32" - - - -	1.80/ft.
1 - 7/16" - - - -	2.00/ft.

VACUUM PUMP & GAUGE

TYPE	PRICE
HV-1	\$125.00
Pump Oil - Qt.	5.00
100 IG	22.50

VACUUM SWITCH

	PRICE
VS-2	\$13.25
12V Coil	11.75
24V Coil	12.50

Since 1945 all new tube types developed by Eitel-McCullough, Inc., have been given a type number chosen according to a coded numbering scheme. This system is designed to convey descriptive information about the tube.

To illustrate the method of coding and the information the type number conveys, a 2½ kw forced-air cooled Eimac triode, type number 3X2500A3, is broken down as follows:

3X2500A3

Number of Electrodes

- 2 Indicates Diode
- 3 Indicates Triode
- 4 Indicates Tetrode
- 5 Indicates Pentode etc.

**Plate
Dissipation**
(Watts)

Mu Group

- 1 Indicates mu from 0 to 10.
- 2 Indicates mu from 11 to 20.
- 3 Indicates mu from 21 to 30. etc.

Description

- *R or - Radiation cooled, internal anode.
- X External anode, air-cooled tube.
- W Water-cooled anode.
- PR Intended for pulse work, radiation cooled, internal anode.
- PX Intended for pulse work, external anode, air-cooled.
- PW Intended for pulse work, water-cooled anode.

*In type numbers chosen for future tubes, the letter "R" will be used in place of the dash to indicate a radiation cooled tube of the internal anode construction.

Version

Indicates tubes which, although alike as to the number of elements and plate dissipation, are not necessarily interchangeable either electrically or physically.

Eimac Tube Type Numbering System for Velocity Modulated Tubes (Klystron, Travelling Wave, etc.)

To illustrate the method of coding and the information the type number conveys, the Eimac 5 kw output Klystron for the lowest third of the UHF television band, type number 3K20,000LA, is broken down as follows:

3K20,000LA

Number of Cavities

This is the number of interaction regions along the beam. A reflex klystron would be considered to have one interaction space; a travelling wave tube with a distributed circuit would be considered as having "zero" cavities because there are no well defined interaction regions.

Dissipation Rating (Watts)

Type of Tube

K Klystron
TW Traveling Wave
PK Pulse Klystron
ST Space Charge
Travelling Wave Tube.

Version

Indicates tubes which, although alike as to the number of interaction regions, type, dissipation and frequency band, are not necessarily interchangeable either electrically or physically.

Frequency Band

Predominately an L-band tube
Predominately an X-band tube
etc.

TUBE PERFORMANCE COMPUTER FOR RF AMPLIFIERS (CLASS B, C, AND FREQUENCY MULTIPLIERS)

It is quite easy to make a close estimate of the performance of a vacuum tube in radio frequency power amplifier service, or an approximation in the case of harmonic amplifier service. Such estimates will give RF output power, DC input power, grid driving power and all DC current values.

These estimates can be made easily by using the Eimac Tube Performance Computer and the characteristic curves of a tube, plotted on plate voltage/grid voltage curves (constant current curves). Only the ability to multiply out figures taken from the curves by means of the computer is required.

By graphically laying out the trace of the plate and grid voltages as they rise and fall about the applied DC plate voltage and DC grid bias a clearer understanding is possible of the action taking place within a tube. With such an understanding the operating conditions can be altered readily to suit one's particular requirements.

Simple Action in Class C RF Amplifiers

In an amplifier a varying voltage is applied to the control grid of the tube. Simultaneously the plate voltage will vary in a similar manner, due to the action of the amplified current flowing in the plate circuit. In radio frequency applications with resonant circuits these voltage variations are smooth sine wave variations, 180° out of phase (as the grid voltage rises and becomes more positive, the plate voltage falls and becomes less positive) as indicated in Fig. 1. Note how these variations center about the DC plate voltage and the DC control grid bias.

Let us now see how such variations of the plate and grid voltages of a tube appear on the constant current curve sheet of a tube. In Fig. 2 these

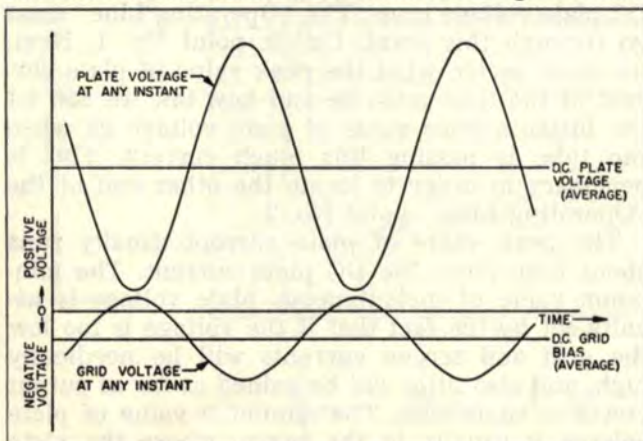

Figure 1

variations have been indicated next to the plate voltage and grid voltage scales of a typical constant current curve. At some instant of time, shown as "t" on the time scales, the grid voltage has a value which is the point marked "eg" on the grid voltage sine wave. At this same instant of time the plate voltage has a value which is the point "ep" marked on the plate voltage sine wave. If now one finds the point on the tube curve sheet corresponding to these values (where a line drawn from "eg" and a line drawn from "ep" cross) he will be at point A in Fig. 2. As the values of grid voltage "eg" and plate voltage "ep" vary over the RF cycle, the point A moves up and down a line, which in the case of the normal RF power amplifier is a straight line. This line is called the "Operating Line."

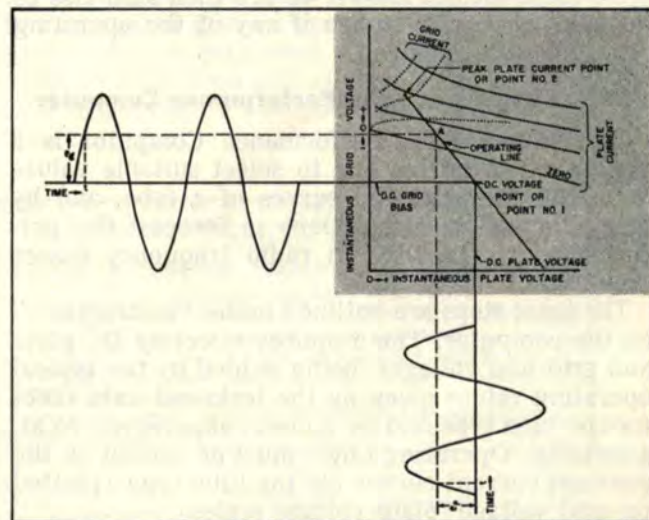

Figure 2

Any point on the operating line (when drawn on a curve sheet as in Fig. 2 or Fig. 4) tells the instantaneous values of plate current, screen current, and grid current which must flow when those particular values of grid and plate voltage are applied to the tube. Thus by reading off the values of the currents and plotting them against the time, t, one can obtain a curve of instantaneous values of plate and grid current. See Fig. 3.

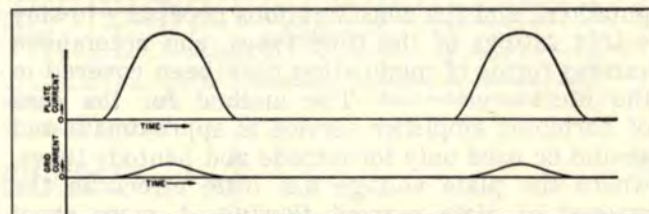

Figure 3

If we analyze the plate and grid current values shown, we can predict that they will cause a DC ammeter to show a particular reading. This is called the DC component of the current. Also, we can predict that if the plate current flows through a properly loaded resonant RF circuit a certain amount of radio frequency power will be delivered to that circuit. If the circuit is tuned to the fundamental frequency (same frequency as the RF grid voltage) the power delivered will be due to the fundamental (or principle radio frequency) component of plate current. If the circuit is tuned to a harmonic of the grid voltage frequency (for instance, two, or three times the frequency) the power delivered will be due to a harmonic component of the plate current.

The Eimac Tube Performance Computer gives us the means to make these simple calculations. It is a means with which to determine the DC component, the fundamental RF component, or the approximate harmonic component of the current flowing in a tube when the tube is operating as a radio frequency amplifier, and enables one to state what all meter readings will be, and to predict the RF output power and the required driving power. With these factors known we are then able also to forecast what will happen if any of the operating conditions are changed.

Use of the Eimac Tube Performance Computer

The Eimac Tube Performance Computer is a simple aid to enable one to select suitable values from the characteristic curves of a tube, and by means of simple calculations to forecast the performance of the tube in radio frequency power amplifiers.

The basic steps are outlined under "Instructions" on the computer. This requires selecting DC plate and grid bias voltages, being guided by the typical operating values given on the technical data sheet for the tube type and by general experience. Next, a suitable "Operating Line" must be chosen on the constant current curves for the tube type (plotted on grid voltage/plate voltage scales).

The computer when properly placed over this operating line enables one to obtain instantaneous values of the currents flowing at every 15° of the electrical cycle. The formulas given on the computer were derived by Chaffee to give the various average and harmonic components of the resulting currents. Knowing these current component values and the radio frequency voltage values which are indicated by the use of the computer, one can readily calculate the complete performance of the tube.

The fundamental methods of making such computations, and the considerations necessary to stay within ratings of the tube types, and accomplish various forms of modulation have been covered in the literature.^{2,3,4,5,6,7} The method for the case of harmonic amplifier service is approximate and should be used only for tetrode and pentode tubes, where the plate voltage has little effect on the amount of plate current flowing. A more exact method, showing that for harmonic operation the

operating line is a simple Lissajon figure, has been described by Brown.⁸

The results of using this computer for power amplifier service can be applied in combination with the other methods given in the literature to give good accuracy with simpler procedures. The resulting accuracy is well within the normal variation of tube characteristics due to the normal variation in manufacturing dimensions of a tube. Since the published tube curves are only typical of the characteristics to be expected from a particular tube type, the calculated performance is well within the values expected when different tubes of a given tube type are operated under the assumed conditions.

Example Showing Detailed Use of the Eimac Tube Performance Computer Radio Frequency Power Amplifier, Class C (Telegraphy or FM)

Let us say we have an Eimac 4-65A tetrode and want to make it work effectively. Also let us say we have a 2000 volt DC plate power supply available.

Within frequency limits, we know a tube should be able to run in class-C amplifier service with about 75% efficiency, or, in other words, to convert 75% of the DC plate input power into RF output power. The difference, or 25% of the input power, is dissipated or lost as heat on the plate of the tube. The DC plate input power is then about four times the power dissipated on the plate.

The 4-65A tetrode has a maximum rated plate dissipation of 65 watts, so, to illustrate performance near the maximum rating, we'll choose an input power four times the plate dissipation, or 260 watts per tube. At 2000 volts the plate current per tube must then be 130 ma. It is usual practice, in the case of tetrodes and the medium or low mu triodes in class-C amplifier service for the DC grid bias voltage to be roughly two or three times the grid voltage necessary to cut off the flow of plate current. By referring to the curves of the 4-65A we decide to use a DC grid bias voltage of -120 volts.

Let us now locate the "Operating Line" on the constant current curves of the 4-65A. See Fig. 4. First mark the point where the DC grid bias and DC plate voltage cross. The "Operating Line" must go through this point. Call it point No. 1. Next, we must decide what the peak value of plate current of the tube must be and how low we can let the instantaneous value of plate voltage go when the tube is passing this much current. This is necessary in order to locate the other end of the "Operating Line," point No. 2.

The peak value of plate current usually runs about four times the DC plate current. The minimum value of instantaneous plate voltage is usually set by the fact that if the voltage is too low the grid and screen currents will be needlessly high, and also little will be gained as far as output power is concerned. The minimum value of plate voltage is usually in the region where the plate constant current curves bend upward. See Fig.

4. (In the case of the triode this is near the "diode line" or line where the instantaneous grid and plate voltages are equal.) The practical procedure in calculating tube performance is to arbitrarily choose point No. 2 and complete the calculations. Then try other locations of point No. 2, complete the calculations, and compare the results.

In the case of the 4-65A let us choose a peak value of plate current about four times the DC plate current of 130 ma, or 500 ma. Let us choose a minimum instantaneous plate voltage of 250 volts and thus fix the upper end of the "Operating Line." Next, locate this point on the tube curves. This is point No. 2 on Fig. 4. (The plate currents which flow at various combinations of plate and grid voltages are shown by the plate current lines. The value of current for each line is noted. In-between values can be estimated closely enough for our purposes.) Now draw a straight line between points No. 1 and No. 2. This line is the "Operating Line" and shows the current and voltage values for each part of the RF cycle when current is being taken from the tube. (The non-conducting half of the RF cycle would be shown by extending this line an equal distance on the opposite side of point No. 1. However, there is little use in so doing because no current flows during this half of the cycle.)

The Eimac Tube Performance Computer can now be used to obtain the meter readings and power values from this "Operating Line." Place the com-

puter on the constant current curve sheet so that the "guide lines" of the computer are parallel with the operating line. Now slide the computer about without turning it until the line OG passes through the DC voltage point No. 1 and line OA passes through the peak current point No. 2. Make sure the guide lines are still parallel to the "Operating Line."

Note that the lines OB, OC, OD, OE and OF of the computer all cross over the "Operating Line."

At each point where the lines OA, OB, etc., cross the "Operating Line" we need to determine the instantaneous values of plate current and grid current (and screen current if a tetrode or pentode is used) which is flowing at that particular moment in the RF cycle. Later, from these key values of current, we will calculate the values of DC plate current and grid current (and screen current) as well as the RF components of the plate current.

At each of these points, where the instantaneous current values are to be determined, a mark should be made on the constant current curve sheet of the tube. By noting where this mark lies with respect to the plate current curves, one can estimate the value of plate current flowing at this part of the cycle. Next, the location of this mark with respect to the control grid curves is noted and a value of grid current is estimated. Finally, by referring the mark to the screen grid curves, if the tube is a tetrode or pentode, a value of screen current is noted. These current values should be listed for each

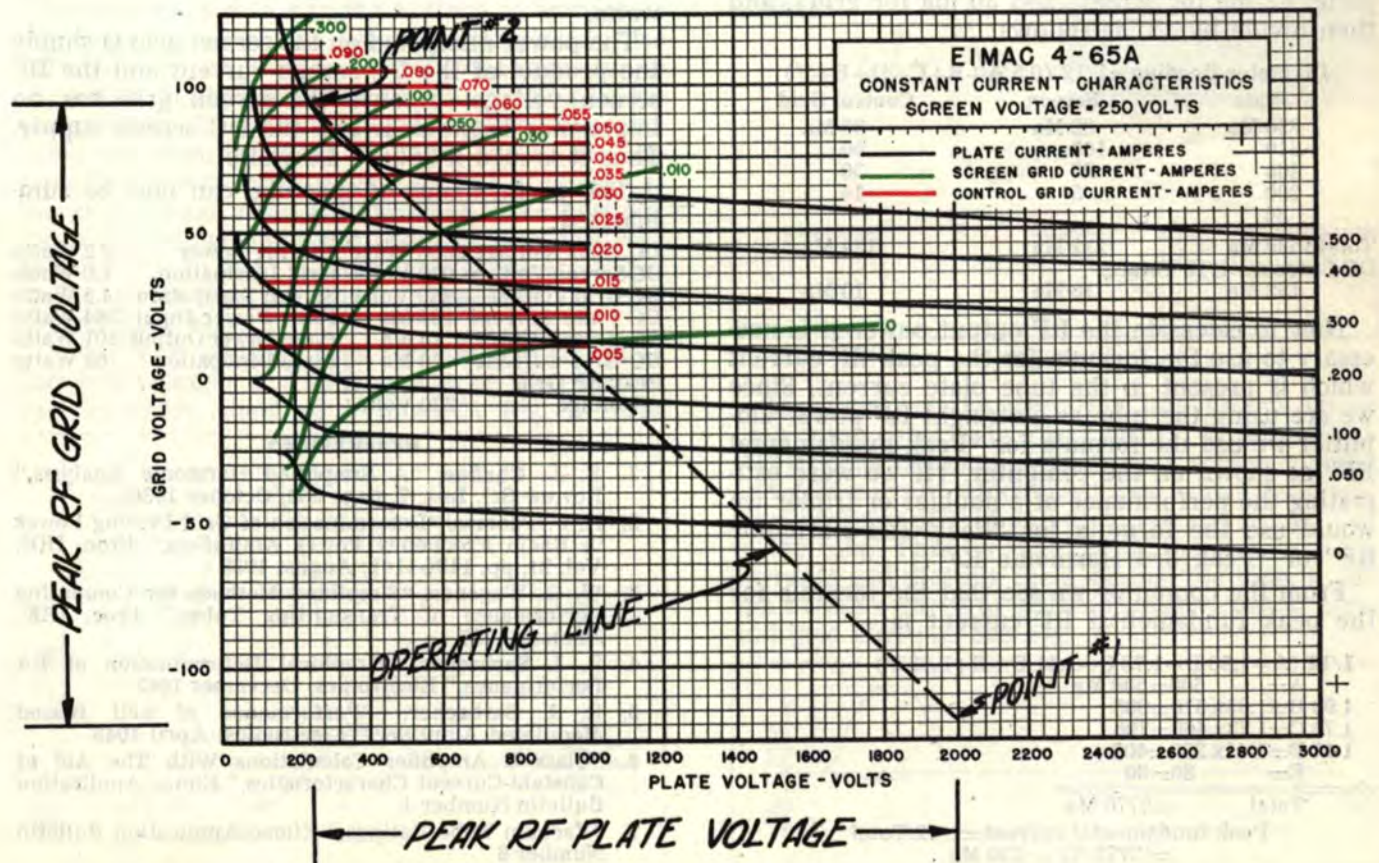

Figure 4

point where the lines OA, OB, etc., cross the operating line so that they can be combined later to calculate the various tube currents. At points where OF and OE cross, the current values are often zero.

Now in the example chosen, let us read off the instantaneous plate current values where these lines cross the "Operating Line." At the point where the line OA crosses the "Operating Line" the plate current is 500 ma. Where OB crosses the operating line the plate current can be estimated as 510 ma since the point is about 1/10 of the way from the 500 ma line to the 600 ma line. At OC the plate current is 460 ma, OD 290 ma, OE 75 ma, OF and OG 0 ma. Similarly we can estimate the instantaneous screen current at the crossing of OA and the "Operating Line" as 165 ma, and the instantaneous grid current at 60 ma. Values are read for the other crossings and written down. These values are put in simple columns for calculating:

Crossing of line	Simplified Name in Formulas	Instantaneous Values of Currents		
		Plate	Screen	Control Grid
OA	A	500 Ma	165 Ma	60 Ma
OB	B	510	100	50
OC	C	460	25	30
OD	D	290	5	14
OE	E	80	0	0
OF	F	0	0	0

Now in order to obtain the DC value of plate, screen, and control grid currents the formula (see computer) says to add up the above values but use only one-half of the A values (giving 250 ma for plate, 82 ma for screen, and 30 ma for grid), and then divide by 12, as follows:

$$\text{DC Meter Reading} = 1/12 (0.5 A + B + C + D + E + F)$$

Plate	Screen	Control Grid
250 Ma	82 Ma	30 Ma
510	100	50
460	25	30
290	5	14
80		
<hr/>	<hr/>	<hr/>
Total 1590 Ma	212 Ma	124 Ma
DC Current = 1/12 Total =		
132 Ma	18 Ma	10 Ma

Now to calculate the RF output power it is necessary to use the formula for the peak RF current which is present in the tube plate current. Since we are using the tube as a straight RF power amplifier we use the formula for "Peak Fundamental RF" as shown on the computer. (If we were estimating the performance of a doubler or tripler we would use the formula for "Peak 2nd Harmonic RF" or "Peak 3rd Harmonic RF".)

From the computer we see that the formula for the peak fundamental RF current is:

$$1/12 (A + 1.93 B + 1.73 C + 1.41 D + E + 0.52 F)$$

$$A = 500 = 500 \text{ Ma}$$

$$1.93 B = 1.93 \times 510 = 985$$

$$1.73 C = 1.73 \times 460 = 796$$

$$1.41 D = 1.41 \times 290 = 409$$

$$E = 80 = 80$$

$$\text{Total} = 2770 \text{ Ma}$$

$$\text{Peak fundamental current} = 1/12 \text{ Total} = 2770/12 = 230 \text{ Ma}$$

We now have the various current values. In

order to calculate the powers involved it is necessary to know, not only the DC voltage values, but the greatest amount each voltage swings away from the DC value. This is known as the peak value of the RF voltage. Because the plate voltage swings from 2000 volts down to 250 volts the peak RF voltage is the difference, or 1750 volts. Similarly the grid voltage must rise and fall between the operating points No. 1 and No. 2, or from -125 volts to +95 volts. This is a peak swing of 220 volts and the peak RF grid voltage is 220 volts.

Let us now use the formulas for output power and driving power:

Output power = $1/2$ peak RF plate current x peak RF plate voltage.

We found the peak RF plate current to be 230 ma or .230 amperes, and the peak RF plate voltage to be 1750 volts.

So; Output Power = $1/2 \times .230 \times 1750 = 201$ watts,
and Input Power = DC Plate Current x DC Plate Voltage

Plate Dissipation = DC Input Power - RF Output Power

Efficiency = RF Output Power divided by DC Input Power

Driving Power = DC Grid Current x Peak RF Grid Voltage

So the Driving Power = $.010 \times 220 = 2.2$ watts

The power consumed by the bias source is simply the product of the DC grid current and the DC grid voltage, or $.010 \times 120 = 1.2$ watts.

The difference between the driving power and the power consumed by the bias source is the power dissipated on the control grid, or $2.2 - 1.2 = 1.0$ watts.

The power dissipated on the screen grid is simply the product of the DC screen current and the DC screen voltage, because the screen grid has no impedance between it and the DC screen supply. Thus it is $.018 \times 250 = 4.5$ watts.

The performance of the tube can now be summarized:

DC Plate Voltage 2000 Volts	Driving Power	2.2 Watts
DC Screen Voltage 250 Volts	Grid Dissipation	1.0 Watts
DC Grid Voltage -120 Volts	Screen Dissipation	4.5 Watts
DC Plate Current 132 Ma	Plate Power Input	264 Watts
DC Screen Current 18 Ma	Plate Power Output	201 Watts
DC Grid Current 10 Ma	Plate Dissipation	63 Watts
Peak RF Grid Voltage	220 Volts	

REFERENCES

1. E. L. Chaffee, "A Simplified Harmonic Analysis," Review Sci. Inst. 7, page 384, October 1936
2. H. P. Thomas, "Determination of Grid Driving Power in Radio Frequency Power Amplifiers," Proc. IRE, Vol. 21, pp. 1134-1141; August 1933
3. W. G. Wagener, "Simplified Methods for Computing Performance of Transmitting Tubes," Proc. IRE; January 1937
4. R. I. Sarbacher, "Graphical Determination of PA Performance," Electronics; December 1942
5. R. I. Sarbacher, "Performance of Self Biased Modulated Amplifier," Electronics; April 1943
6. "Class C Amplifier Calculations With The Aid of Constant-Current Characteristics," Eimac Application Bulletin Number 4
7. "Vacuum Tube Ratings," Eimac Application Bulletin Number 6
8. Robert H. Brown, "Harmonic Amplifier Design," Proc. IRE, Vol. 35 pp. 771-777; August 1947

Eimac
EITEL-McCULLOUGH, INC.
SAN BRUNO, CALIFORNIA

TUBE PERFORMANCE COMPUTOR
For RF Amplifiers (Class B, C, and Frequency Multipliers)

Use with constant current curves to obtain plate, grid, and screen current values; also output and driving power.

DC Current (meter reading)	1/12 (0.5A+B+C+D+E+F)
Peak Fundamental RF	1/12 (A+1.93B+1.73C+1.41D+E+0.52F)
Peak 2nd Harmonic RF (Approx.)*	1/12 (A+1.73B+C-E-1.73F)
Peak 3rd Harmonic RF (Approx.)*	1/12 (A+1.41B-1.41D-2E-1.41F)

Output Power = 1/2 Peak RF plate current X Peak RF Plate Voltage
Driving Power = DC Grid Current X Peak RF Grid Voltage

*Use only for tetrodes or pentodes—Approximate Only.

INSTRUCTIONS

1. Mark point of DC plate voltage and DC Grid Bias.
2. Mark point of peak plate current in low plate voltage region. (This is about four times DC plate current).
3. Draw straight line between points selected in No. 1 & No. 2. This is "Operating Line."
4. Place computer on curve sheet with guide lines parallel to "Operating Line." Make OG line of computer go through point of Step No. 1. Make OA line of computer go through point of Step No. 2.
5. Read current values where "Operating Line" crosses OA, OB, OC, OD, OE, and OF.
6. Put values in formulas as A, B, C, D, E, & F.

For detailed instructions see Eimac Application Bulletin No. 5.

www.SteamPoweredRadio.Com

GUIDE LINES

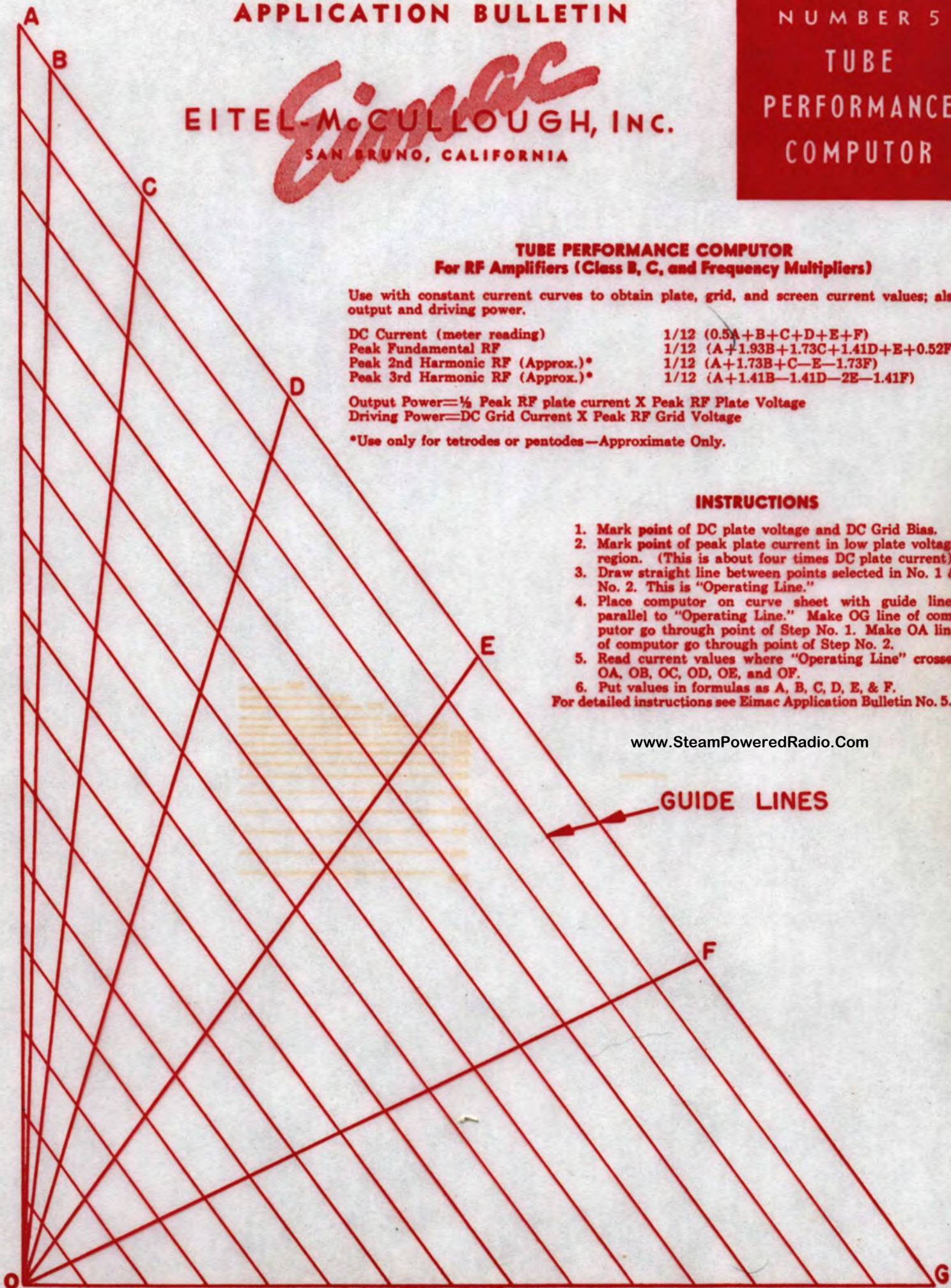

Eitel-McCULLOUGH, INC.

SAN BRUNO, CALIFORNIA

4-65A

RADIAL-BEAM
POWER TRODE
MODULATOR
OSCILLATOR
AMPLIFIER

The Eimac 4-65A is a small radiation-cooled transmitting tetrode having a maximum plate dissipation rating of 65 watts. The plate operates at a red color at maximum dissipation. Short, heavy leads and low interelectrode capacitances contribute to stable efficient operation at high frequencies.

Although it is capable of withstanding high plate voltages, the internal geometry of the 4-65A is such that it will deliver relatively high power output at a low plate voltage.

The quick-heating filament allows conservation of power during standby periods in mobile applications.

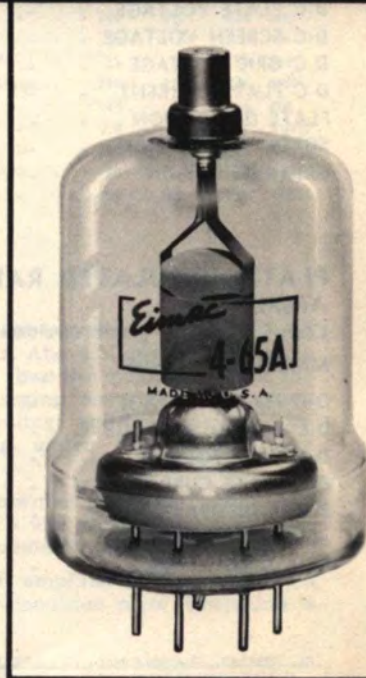

GENERAL CHARACTERISTICS

ELECTRICAL

Filament: Thoriated tungsten		
Voltage	- - - - -	6.0 volts
Current	- - - - -	3.5 amperes
Grid-Screen Amplification Factor (Average)		5
Direct Interelectrode Capacitances (Average)		
Grid-Plate	- - - - -	0.08 $\mu\mu\text{fd}$
Input	- - - - -	8.0 $\mu\mu\text{fd}$
Output	- - - - -	2.1 $\mu\mu\text{fd}$
Transconductance (ib = 125 ma., Eb = 500 v., E _{c2} = 250 v.)		4000 μmhos
Frequency for Maximum Ratings		150 Mc.

MECHANICAL

▶ Base	- - - - -	5-pin—Fits	{	National HX-29' Socket Johnson 122-101 Socket
Mounting	- - - - -			Vertical, base down or up
Cooling	- - - - -			Convection and Radiation
Maximum Overall Dimensions				
Length	- - - - -			4.38 inches
Diameter	- - - - -			2.38 inches
Net Weight	- - - - -			3 ounces
Shipping Weight (Average)	- - - - -			1.5 pounds

IF IT IS DESIRED TO OPERATE THIS TUBE UNDER CONDITIONS WIDELY DIFFERENT THAN THOSE GIVEN UNDER "TYPICAL OPERATION," POSSIBLY EXCEEDING MAXIMUM RATINGS, WRITE EITEL-McCULLOUGH, INC., FOR INFORMATION AND RECOMMENDATIONS.

RADIO-FREQUENCY POWER AMPLIFIER AND OSCILLATOR

Class-C Telephony or FM Telephony

MAXIMUM RATINGS (Key-down conditions, per tube)

D-C PLATE VOLTAGE	-	-	-	3000	MAX. VOLTS
D-C SCREEN VOLTAGE	-	-	-	400	MAX. VOLTS
D-C GRID VOLTAGE	-	-	-	—500	MAX. VOLTS
D-C PLATE CURRENT	-	-	-	150	MAX. MA
PLATE DISSIPATION	-	-	-	65	MAX. WATTS
SCREEN DISSIPATION	-	-	-	10	MAX. WATTS
GRID DISSIPATION	-	-	-	5	MAX. WATTS

TYPICAL OPERATION

D-C Plate Voltage	-	-	-	600	1000	1500	2000	3000	volts
D-C Screen Voltage	-	-	-	250	250	250	250	250	volts
D-C Grid Voltage	-	-	-	—50	—70	—75	—80	—90	volts
D-C Plate Current	-	-	-	140	150	150	150	115	ma
D-C Screen Current	-	-	-	40	40	35	30	20	ma
D-C Grid Current	-	-	-	13	15	14	12	10	ma
Peak R-F Grid Input Voltage (approx.)	-	-	-	145	170	180	175	170	volts
Driving Power (approx.)	-	-	-	1.9	2.5	2.5	2.1	1.7	watts
Screen Dissipation	-	-	-	10	10	9	8	5	watts
Plate Power Input	-	-	-	84	150	225	300	345	watts
Plate Dissipation	-	-	-	30	45	55	65	65	watts
Plate Power Output	-	-	-	54	105	170	235	280	watts

PLATE-MODULATED RADIO-FREQUENCY AMPLIFIER

Class-C Telephony (Carrier conditions unless otherwise specified, 1 tube)

MAXIMUM RATINGS

D-C PLATE VOLTAGE	-	-	-	2500	MAX. VOLTS
D-C SCREEN VOLTAGE	-	-	-	400	MAX. VOLTS
D-C GRID VOLTAGE	-	-	-	—500	MAX. VOLTS
D-C PLATE CURRENT	-	-	-	120	MAX. MA
PLATE DISSIPATION	-	-	-	45	MAX. WATTS
SCREEN DISSIPATION	-	-	-	10	MAX. WATTS
GRID DISSIPATION	-	-	-	5	MAX. WATTS

TYPICAL OPERATION

D-C Plate Voltage	-	-	-	600	1000	1500	2000	2500	volts
D-C Screen Voltage	-	-	-	250	250	250	250	250	volts
D-C Grid Voltage	-	-	-	—100	—110	—125	—125	—150	volts
D-C Plate Current	-	-	-	117	120	120	120	108	ma
D-C Screen Current	-	-	-	40	40	35	33	16	ma
D-C Grid Current	-	-	-	11	12	12	12	8	ma
Screen Dissipation	-	-	-	10	10	9	8	4	watts
Grid Dissipation	-	-	-	1.0	1.2	1.2	1.1	.7	watts
Peak A-F Screen Voltage, 100% Modulation	-	-	-	175	175	175	175	175	volts
Peak R-F Grid Input Voltage (approx.)	-	-	-	190	210	225	225	235	volts
Driving Power (approx.)	-	-	-	2.1	2.5	2.7	2.6	1.9	watts
Plate Power Input	-	-	-	70	120	180	240	270	watts
Plate Dissipation	-	-	-	20	25	35	40	45	watts
Plate Power Output	-	-	-	50	95	145	200	225	watts

Note: Typical operation data are based on conditions of adjusting to a specified plate current, maintaining fixed conditions of grid bias, screen voltage, and r-f grid voltage. It will be found that if this procedure is followed, there will be little variation in power output between tubes even though there may be some variations in grid and screen currents. Where grid bias is obtained principally by means of a grid resistor, to control plate current it is necessary to make the resistor adjustable.

AUDIO-FREQUENCY POWER AMPLIFIER AND MODULATOR

MAXIMUM RATINGS (PER TUBE)

D-C PLATE VOLTAGE	-	-	-	-	-	-	-	-	-	3000	MAX. VOLTS
D-C SCREEN VOLTAGE	-	-	-	-	-	-	-	-	-	600	MAX. VOLTS
MAX-SIGNAL D-C PLATE CURRENT, PER TUBE	-	-	-	-	-	-	-	-	-	150	MAX. MA
PLATE DISSIPATION, PER TUBE	-	-	-	-	-	-	-	-	-	65	MAX. WATTS
SCREEN DISSIPATION, PER TUBE	-	-	-	-	-	-	-	-	-	10	MAX. WATTS

TYPICAL OPERATION

Class-AB₁ (Sinusoidal wave, two tubes unless otherwise specified)

D-C Plate Voltage	-	-	-	1000	1500	1750	volts
D-C Screen Voltage	-	-	-	500	500	500	volts
D-C Grid Voltage (approx.)*	-	-	-	—85	—85	—90	volts
Zero-Signal D-C Plate Current	-	-	-	30	30	20	ma
Max-Signal D-C Plate Current	-	-	-	170	180	170	ma
Zero-Signal D-C Screen Current	-	-	-	0	0	0	ma
Max-Signal D-C Screen Current	-	-	-	24	14	17	ma
Effective Load, Plate-to-Plate	-	-	-	9000	15,000	20,000	ohms
Peak A-F Grid Input Voltage (per tube)	-	-	-	85	85	90	volts
Driving Power	-	-	-	0	0	0	watts
Max-Signal Plate Dissipation (per tube)	-	-	-	45	63	62	watts
Max-Signal Plate Power Output	-	-	-	80	145	175	watts

*Adjust to give stated zero signal plate current.

The effective grid circuit resistance for each tube must not exceed 250,000 ohms.

TYPICAL OPERATION

Class-AB₂ (Sinusoidal wave, two tubes unless otherwise specified)

D-C Plate Voltage	-	-	-	600	1000	1500	1800	volts
D-C Screen Voltage	-	-	-	250	250	250	250	volts
D-C Grid Voltage (approx.)**	-	-	-	—30	—30	—35	—35	volts
Zero-Signal D-C Plate Current	-	-	-	60	60	60	50	ma
Max-Signal D-C Plate Current	-	-	-	300	300	250	220	ma
Zero-Signal D-C Screen Current	-	-	-	0	0	0	0	ma
Max-Signal D-C Screen Current	-	-	-	60	45	30	25	ma
Effective Load, Plate-to-Plate	-	-	-	3600	6800	14,000	20,000	ohms
Peak A-F Grid Input Voltage (per tube)	-	-	-	120	105	100	90	volts
Max-Signal Peak Driving Power	-	-	-	6.2	5.0	3.2	2.2	watts
Max-Signal Nominal Driving Power (approx.)	-	-	-	3.1	2.5	1.6	1.1	watts
Max-Signal Plate Dissipation (per tube)	-	-	-	45	65	63	63	watts
Max-Signal Plate Power Output	-	-	-	90	170	250	270	watts

**Adjust to give stated zero signal plate current.

► Indicates change from sheet dated 8-15-51

**RADIO-FREQUENCY LINEAR POWER AMPLIFIER
SINGLE SIDE BAND SUPPRESSED CARRIER
Class-B (One tube)**

MAXIMUM RATINGS

D-C PLATE VOLTAGE	- - - - -	3000 MAX. VOLTS
D-C SCREEN VOLTAGE	- - - - -	600 MAX. VOLTS
PLATE DISSIPATION	- - - - -	65 MAX. WATTS
SCREEN DISSIPATION	- - - - -	10 MAX. WATTS
GRID DISSIPATION	- - - - -	5 MAX. WATTS

*Adjust to give stated zero-signal plate current.
**Due to intermittent nature of voice average dissipation is considerably less than Max-Signal Dissipation.

TYPICAL OPERATION

D-C Plate Voltage	- - - - -	1500	2000	2500	volts
D-C Screen Voltage	- - - - -	300	400	500	volts
D-C Grid Voltage (approx.)*	- - - - -	-50	-75	-100	volts
Zero-Signal D-C Plate Current	- - - - -	33	25	20	ma
Max-Signal D-C Plate Current	- - - - -	200	270	230	ma
Zero-Signal D-C Screen Current	- - - - -	0	0	0	ma
Max-Signal D-C Screen Current **	- - - - -	35	50	35	ma
Max-Signal Peak R. F. Grid Voltage	- - - - -	190	270	300	volts
Max-Signal Avg. Grid Current	- - - - -	13	17	6	ma
Max-Signal Avg. Driving Power	- - - - -	2.4	4.6	1.8	watts
Max-Signal Plate Dissipation**	- - - - -	105	190	225	watts
Average Plate Dissipation	- - - - -	60	65	65	watts
Max-Signal Useful Power Output	- - - - -	150	300	325	watts

APPLICATION

MECHANICAL

Mounting—The 4-65A must be mounted vertically, base up or base down. The socket must provide clearance for the glass tip-off which extends from the center of the base. A flexible connecting strap should be provided between the plate terminal and the external plate circuit, and the Eimac HR6 cooler used on the tube plate lead. The socket must not apply lateral pressure against the base pins. The tube must be protected from severe vibration and shock.

Adequate ventilation must be provided so that the seals and envelope under operating conditions do not exceed 225°C. For operation above 50 Mc., the plate voltage should be reduced, or special attention should be given to seal cooling.

In intermittent-service applications where the "on" time does not exceed a total of five minutes in any ten minute period, plate seal temperatures as high as 250°C are permissible. When the ambient temperature does not exceed 30°C it will not ordinarily be necessary to provide forced cooling of the bulb and plate seal to hold the temperature below this maximum at frequencies below 50 Mc, provided that a heat-radiating plate connector is used, and the tube is so located that normal circulation of air past the envelope is not impeded.

ELECTRICAL

Filament Voltage—The filament voltage, as measured directly at the filament pins, should be between 5.7 volts and 6.3 volts.

Bias Voltage—D-C bias voltage for the 4-65A should not exceed -500 volts. If grid-leak bias is used, suitable protective means must be provided to prevent excessive plate or screen dissipation in the event of loss of excitation.

Grid Dissipation—Grid dissipation for the 4-65A should not be allowed to exceed five watts. Grid dissipation may be calculated from the following expression:

$$P_g = e_{cmp} I_c$$

where P_g = Grid dissipation,
 e_{cmp} = Peak positive grid voltage, and
 I_c = D-c grid current.

e_{cmp} may be measured by means of a suitable peak voltmeter connected between filament and grid*

Screen Voltage—The D-C screen voltage for the 4-65A should not exceed 400 volts except in the case of class-AB audio operation and Single Side Band R-F amplifier operation where it should not exceed 600 volts.

Screen Dissipation—The power dissipated by the screen of the 4-65A must not exceed 10 watts. Screen dissipation is likely to rise to excessive values when the plate voltage, bias voltage or plate load is removed with filament and screen voltages applied. Suitable protective means must be provided to limit screen dissipation to 10 watts in the event of circuit failure.

Plate Voltage—The plate-supply voltage for the 4-65A should not exceed 3,000 volts. Above 50-Mc. it is advisable to use a lower plate voltage than the maximum, since the seal heating due to R-F charging currents in the screen leads increases with plate voltage and frequency. See instructions on seal cooling under "Mechanical" and "shielding."

Plate Dissipation—Under normal operating conditions, the plate dissipation of the 4-65A should not be allowed to exceed 65 watts in unmodulated applications.

In high-level-modulated amplifier applications, the maximum allowable carrier-condition plate dissipation is 45 watts.

Plate dissipation in excess of maximum rating is permissible for short periods of time, such as during tuning procedures.

OPERATION

Class-C FM or Telegraphy—The 4-65A may be operated as a class-C FM or telegraph amplifier without neutralization up to 110 Mc. if reasonable precautions are taken to prevent coupling between input and output circuits external to the tube. In single ended circuits, plate, grid, filament and screen by-pass capacitors should be returned through the shortest possible leads to a common chassis point. In push-pull applications the filament and screen terminals of each tube should be by-passed to a common chassis point by the shortest possible leads, and short, heavy leads should be used to interconnect the screens and filaments of the two tubes. Care should be taken to prevent leakage of radio-frequency energy to leads entering the amplifier, in order to minimize grid-plate coupling between these leads external to the amplifier.

Where shielding is adequate, the feedback at frequencies above 110 Mc. is due principally to screen-lead-inductance effects, and it becomes necessary to introduce in-phase voltage from the plate circuit into the grid circuit. This can be done by adding capacitance between plate and grid external to the tube. Ordinary, a small metal tab approximately 3/8" square and located adjacent to the envelope opposite the plate will suffice for neutralization. Means should be provided for adjusting the spacing between the neutralizing capacitor plate and the envelope. An alternate neutralization scheme for use above 110 Mc., is illustrated in the diagram on page 4. In this circuit, feedback is eliminated by series-tuning the screen to ground with a small capacitor. The socket screen terminals should be strapped together as shown on the

*For suitable peak V.T.V.M. circuits see, for instance, "Vacuum Tube Ratings," Eimac News, January 1945. This article is available in reprint form on request.

$R = \frac{E}{I}$

83
120 / 1000000
96
40
40

diagram, by the shortest possible lead, and the lead from the mid point of this screen strap to the capacitor, C, and from the capacitor to ground should be made as short as possible.

Driving power and power output under maximum output and plate voltage conditions are shown on page 2. The power output shown is the actual plate power delivered by the tube; the power delivered to the load will depend upon the efficiency of the plate tank and output coupling system. The driving power is likewise the driving power required by the tube (includes bias loss). The driver output power should exceed the driving power requirements by a sufficient margin to allow for coupling-circuit losses. The use of silver-plated linear tank-circuit elements is recommended for all frequencies above 75 Mc.

Class-C AM Telephony—The R-F circuit considerations discussed above under Class-C FM or Telegraphy also apply to amplitude-modulated operation of the 4-65A. When the 4-65A is used as a class-C high-level-modulated

ing reasonably good regulation, to prevent variations in screen voltage from zero-signal to maximum-signal conditions. The use of voltage regulator tubes in a standard circuit should provide adequate regulation.

Grid bias voltage for class AB₁ service may be obtained from batteries or from a small fixed-bias supply. When a bias supply is used, the D-C resistance of the bias source should not exceed 250 ohms. Under class-AB₁ conditions the effective grid-circuit resistance should not exceed 250,000 ohms.

The peak driving power figures given in the class-AB₁ tabulated data are included to make possible an accurate determination of the required driver output power. The driver amplifier must be capable of supplying the peak driving power without distortion. The driver stage should, therefore, be capable of providing an undistorted average output equal to half the peak driving power requirement. A small amount of additional driver output should be provided to allow for losses in the coupling transformer.

In some cases the maximum-signal plate dissipation shown under "Typical Operation" is less than the maximum rated plate dissipation of 4-65A. In these cases, with sine wave modulation, the plate dissipation reaches a maximum value, equal to the maximum rating, at a point somewhat below maximum-signal conditions.

The power output figures given in the tabulated data refer to the total power output from the amplifier tubes. The useful power output will be from 5 to 15 per cent less than the figures shown, due to losses in the output transformer.

Because of the intermittent nature of the voice, and the low average power, it is possible in cases where size and weight are important to operate a class-AB stage at higher peak power values than those indicated for sine wave.

In order to obtain peak power above that shown for sine wave (peak is twice average for sine wave), the plate-to-plate load impedance must be made proportionately lower than the value shown for a particular plate voltage. Also, more peak driving power will be required. At no time should the average plate or grid dissipation exceed the maximum values shown.

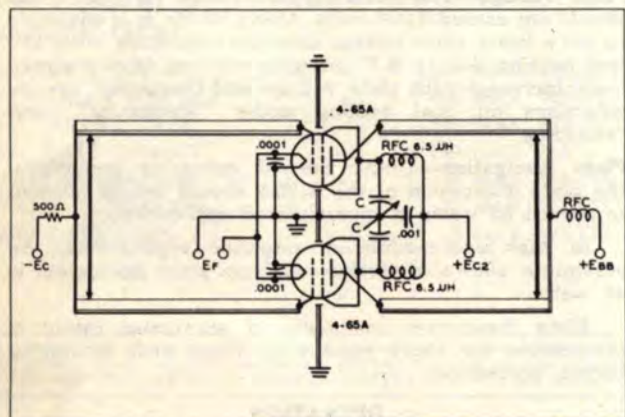

Screen-tuning neutralization circuit for use above 100 Mc.
 C is a small split-stator capacitor.

$$C(\mu\text{fd}) = \frac{640,000}{f^2 (\text{Mc.})}, \text{ approx.}$$

amplifier, both the plate and screen should be modulated. Modulation voltage for the screen is easily obtained by supplying the screen voltage via a series dropping resistor from the unmodulated plate supply, or by the use of an audio-frequency reactor in the positive screen-supply lead, or from a separate winding on the modulation transformer. When screen modulation is obtained by either the series-resistor or the audio-reactor methods, the audio-frequency variations in screen current which result from the variations in plate voltage as the plate is modulated automatically give the required screen modulation. Where a reactor is used, it should have a rated inductance of not less than 10 henries divided by the number of tubes in the modulated amplifier and a maximum current rating of two to three times the operating D-C screen current. To prevent phase-shift between the screen and plate modulation voltages at high audio frequencies, the screen by-pass capacitor should be no larger than necessary for adequate R-F by-passing.

For high-level modulated service, the use of partial grid-leak bias is recommended. Any by-pass capacitors placed across the grid-leak resistance should have a reactance at the highest modulation frequency equal to at least twice the grid-leak resistance.

Class-AB₁ and Class-AB₂ Audio—Two 4-65As may be used in a push-pull circuit to give relatively high audio output power at low distortion. Maximum ratings and typical operating conditions for class-AB₁ and class-AB₂ audio operation are given in the tabulated data.

Screen voltage should be obtained from a source hav-

KEYING THE TETRODE AMPLIFIER

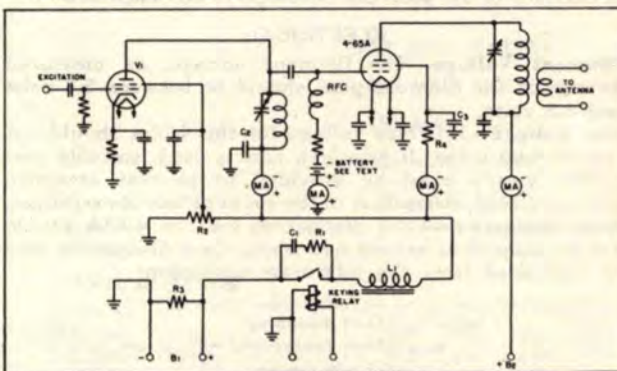

Tetrode Keying Circuit

The flow of plate current in an R-F tetrode amplifier depends not only on the control grid bias and excitation, but also on the voltage applied to the screen grid.

One easy method of keying is to remove the excitation and screen grid voltage simultaneously, while leaving the plate voltage still applied to the amplifier stage. This method also has an advantage in that the final tube can be made to draw a safe amount of current key-up position, maintaining a steadier drain on the power supply while keying. This tends to minimize "blinking lights" on weak AC supply lines when using moderate power. By properly

choosing the values of L, C, and R, in the circuit, perfectly clean-cut highest speed hand keying can easily be obtained that is entirely devoid of clicks.

The keying circuit is shown in the diagram and V₁ is the driver tube, which may be any one of the small tetrodes such as an 807, 6L6 or 6F6, used either as a frequency multiplier or a straight-through amplifier. This tube should furnish about five watts of output power which allows ample driving power for one 4-65A, including circuit losses. Capacitance coupling is shown in the diagram, but this, of course, could just as well be link coupling.

Steady driving power is fed to the grid of V₁ from the exciter. The keying circuit controls the plate and screen voltages on V₁, as well as the screen voltage on the 4-65A, all obtained from a common power supply B₁. This supply should furnish sufficient voltage to the plate of V₁ to obtain the necessary driving power. Normally this voltage will be about the correct voltage for the screen of the 4-65A and resistor R₁ may be omitted.

When the key is up there is no excitation to the 4-65A, and consequently no grid leak bias. At the same time, the screen voltage has also been removed so that very little current is drawn by the plate. With plate voltages up to 2000 volts, the amount of current drawn is not sufficient to heat the plate beyond its rated plate dissipation and a fixed bias is not required. However, with plate voltages over 2000 volts, a small fixed bias supply is needed to keep the plate dissipation within the rated limit. An ordinary 22½ volt C battery in the control grid circuit will furnish sufficient bias to completely cut the plate current off at 3000 volts, while some lower value of bias can be used to permit a safe amount of current to flow in key-up position, presenting a more constant load to the power supply.

A tapped resistor R₂ serves to supply screen voltage to V₁ and by adjusting this tap, the excitation to the 4-65A may be easily controlled. This method of controlling the output of a tetrode is not recommended in the larger tetrodes, however, as it is wasteful of power and the lowered power output obtained is due to a loss in efficiency. R₂ also serves as a means of keeping the screen of the 4-65A at ground potential under key-up conditions, stabilizing the circuit. R₃ is the normal power supply bleeder.

The keying relay must be insulated to withstand the driver plate voltage. Key clicks may be completely eliminated by the proper selection of L₁, R₁ and C₁ in series with and across the relay. In many applications values of 500 ohms for R₁ and 0.25 ufd for C₁ have been found entirely satisfactory. Choke L₁ is best selected by trial and usually is on the order of 5 henries. A satisfactory choke for this purpose can be made by using any small power-supply choke, capable of handling the combined current of the final screen grid and the driver stage, and adjusting the air gap to give the proper inductance. This may be checked by listening for clean keying on the "make" side of the signal or by observation in a 'scope.

R-F by-pass condensers C₂ and C₃ will have some effect on the required value of L₁ as well as C₁. These by-pass condensers should be kept at as small a value of capacity as is needed. In most cases .002 ufd. is sufficient.

SHIELDING

The internal feedback of the tetrode has been substantially eliminated, and in order to fully utilize this advantage, it is essential that the design of the equipment completely eliminates any feedback external to the tube. This means complete shielding of the output circuit from the input circuit and earlier stages, proper reduction to low values of the inductance of the screen lead to the R-F ground, and elimination of R-F feedback in any common power supply leads.

Complete shielding is easily achieved by mounting the socket of the tube flush with the deck of the chassis as shown in the sketch.

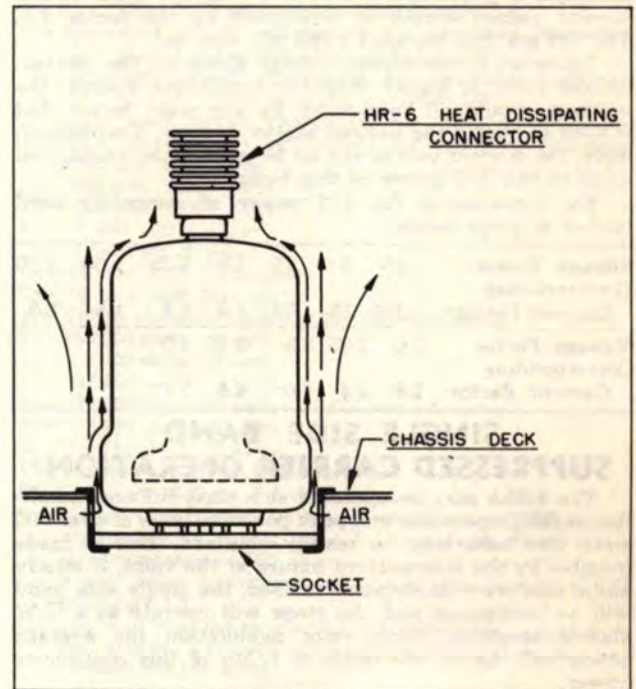

The holes in the socket permit the flow of convection air currents from below the chassis up past the seals in the base of the tube. This flow of air is essential to cool the tube and in cases where the complete under part of the chassis is enclosed for electrical shielding, screened holes or louvers should be provided to permit air circulation. Note that shielding is completed by aligning the internal screen shield with the chassis deck and by proper R-F by-passing of the screen leads to R-F ground. The plate and output circuits should be kept above deck and the input circuit and circuits of earlier stages should be kept below deck or completely shielded.

DIFFERENT SCREEN VOLTAGES

The published characteristic curves of tetrodes are shown for the commonly used screen voltages. Occasionally it is desirable to operate the tetrode at some screen voltage other than that shown on the characteristic curves. It is a relatively simple matter to convert the published curves to corresponding curves at a different screen voltage by the method to be described.

This conversion method is based on the fact that if all inter-electrode voltages are either raised or lowered by the same relative amount, the shape of the voltage field pattern is not altered, nor will the current distribution be altered; the current lines will simply take on new proportionate values in accordance with the three-halves power law. This method fails only where insufficient cathode emission or high secondary emission affect the current values.

For instance, if the characteristic curves are shown at a screen voltage of 250 volts and it is desired to determine conditions at 500 screen volts, all voltage scales should be multiplied by the same factor that is applied to the screen voltage (in this case—2). The 1000 volt plate voltage point now becomes 2000 volts, the 50 volt grid voltage point, 100 volts, etc.

The current lines then all assume new values in accordance with the 3/2 power law. Since the voltage was increased by a factor of 2, the current lines will all be increased in value by a factor of 2^{3/2} or 2.8. Then all the current values should be multiplied by the factor 2.8. The 100 ma. line becomes a 280 ma. line, etc.

Likewise, if the screen voltage given on the characteristic curve is higher than the conditions desired, the voltages should all be reduced by the same factor that is used to obtain the desired screen voltage. Correspondingly, the current values will all be reduced by an amount equal to the 3/2 power of this factor.

For convenience the 3/2 power of commonly used factors is given below:

Voltage Factor	.25	.5	.75	1.0	1.25	1.50	1.75
Corresponding Current Factor	.125	.35	.65	1.0	1.4	1.84	2.3
Voltage Factor	2.0	2.25	2.5	2.75	3.0		
Corresponding Current Factor	2.8	3.4	4.0	4.6	5.2		

SINGLE SIDE BAND SUPPRESSED CARRIER OPERATION

The 4-65A may be operated as a class B linear amplifier in SSSC operation and peak power outputs of over 300 watts per tube may be readily obtained. This is made possible by the intermittent nature of the voice. If steady audio sine wave modulation is used, the single side band will be continuous and the stage will operate as a C-W class-B amplifier. With voice modulation the average power will run on the order of 1/5th of this continuous power.

The same precautions regarding shielding, coupling between input and output circuits, and proper R-F bypassing must be observed, as described under Class-C Telegraphy Operation.

Due to the widely varying nature of the load imposed on the power supplies by SSSC operation, it is essential that particular attention be given to obtaining good regulation in these supplies. The bias supply especially, should have excellent regulation, and the addition of a heavy bleeder to keep the supply well loaded will be found helpful.

Under conditions of zero speech signal, the operating bias is adjusted so as to give a plate dissipation of 50 watts at the desired plate and screen voltages. Due to the intermittent nature of voice, the average plate dissipation will rise only slightly under full speech modulation to approximately 65 watts. At the same time, however, the peak speech power output of over 300 watts is obtained.

SSSC TUNING PROCEDURE

Tuning the SSSC transmitter is best accomplished with the aid of an audio frequency oscillator and a cathode-ray oscilloscope. The audio oscillator should be capable of delivering a sine wave output of a frequency of around 800 to 1000 cycles so that the frequency will be somewhere near the middle of the pass-band of the audio system. Since successful operation of the class-B stage depends on good linearity and the capability of delivering full power at highest audio levels, the final tuning should be made under conditions simulating peak modulation conditions. If a continuous sine wave from the audio oscillator is used for tuning purposes, the average power at full modulation would be about five times that of speech under similar conditions of single side band operation and the final amplifier would be subjected to a heavy overload. One method of lowering the duty cycle of the audio oscillator to closer approximate speech conditions would be to modulate the oscillator with a low frequency.

An alternate method would be to use the continuous audio sine wave, making all adjustments at half voltages and half currents on the screen and plate, thus reducing the power to one quarter. The stand-by plate dissipation under these conditions should be set at about 10 watts. Following these adjustments, minor adjustments at full voltages and 50 watts of stand-by plate dissipation could then be made, but only allowing the full power to remain on for ten or fifteen second intervals.

The first step is to loosely couple the oscilloscope to the output of the exciter unit. The final amplifier with its filament and bias voltages turned on should also be coupled to the exciter at this time. With the audio oscillator running, adjust the exciter unit so that it delivers double side band signals. Using a linear sweep on the oscilloscope, the double side band pattern will appear on the screen the same as that obtained from a 100% sine wave modulated AM signal. Next vary the audio gain control so that the exciter can be checked for linearity. When the peaks of the envelope start to flatten out the upper limit of the exciter output has been reached and the maximum gain setting should be noted. The coupling to the final stage should be varied during this process and a point of optimum coupling determined by watching the oscilloscope pattern and the grid meter in the final stage.

Next, adjust the exciter for single side band operation and if it is working properly, the pattern on the oscilloscope will resemble an unmodulated AM carrier. The phasing controls should be adjusted so as to make the envelope as smooth on the top and bottom as possible. If the above conditions are satisfied, the exciter unit can be assumed to be operating satisfactorily.

Next, loosely couple the oscilloscope link to the output of the final amplifier and again adjust the exciter unit to give double side band output.

If the reduced duty cycle method is used, the following tuning procedure may be followed:

1. Cut the audio output to zero.
2. Apply 120 volts of bias to the 4-65A control grid.
3. Apply the operating plate voltage followed by the operating screen voltage.
4. Reduce bias voltage to obtain 50 watts of stand-by plate dissipation.
5. Increase audio gain, checking the oscilloscope pattern for linearity as in the case of the exciter, and adjust for optimum antenna coupling.
6. Re-adjust exciter unit for single side band operation.
7. Disconnect test signal and connect microphone.
8. Adjust the audio gain so that the voice peaks give the same deflection on the oscilloscope screen as was obtained from the test signal peaks.

If the alternate method is used with a 100% duty cycle from the audio oscillator, then step 3 should be to apply half voltages and the stand-by plate dissipation should be set at 10 watts.

After the audio oscillator is disconnected and step 8 completed at half voltages, the full voltages can then be applied and the stand-by plate dissipation adjusted for 50 watts.

It is essential that the microphone cable be well shielded and grounded to avoid R-F feedback that might not occur when the lower impedance audio oscillator is used as an audio source.

Typical operational data are given for SSSC in the first part of this data sheet.

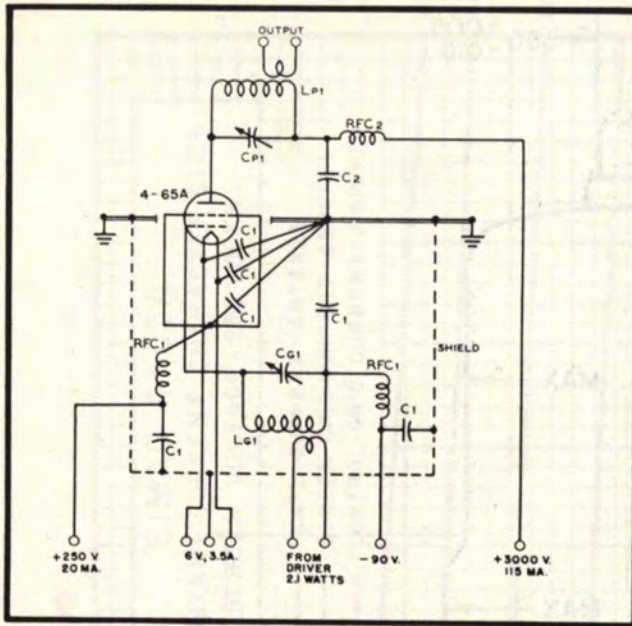

Typical radio-frequency power amplifier circuit, Class-C telegraphy, 345 watts input.

COMPONENTS FOR TYPICAL CIRCUITS

- L_{p1}-C_{p1}— Tank circuit appropriate for operating frequency; Q=12. Capacitor plate spacing=.200"
- L_{p2}-C_{p2}— Tank circuit appropriate for operating frequency; Q=12. Capacitor plate spacing=.200"
- L_{p3}-C_{p3}— Tank circuit appropriate for operating frequency; Q=12. Capacitor plate spacing=.375"
- L_{g1}-C_{g1}— Tuned circuit appropriate for operating frequency.
- L_{g2}-C_{g2}— Tuned circuit appropriate for operating frequency.
- C₁— .002- μ fd. 500V Mica
- C₂— .002- μ fd. 5000V Mica
- C₃— .001- μ fd. 2500V Mica
- C₄— .1- μ fd. 1000V paper
- C₅— .1- μ fd. 600 V paper
- C₆— 16- μ fd. 450V Electrolytic
- C₇— 10- μ fd. 100V Electrolytic
- R₁— 53,000 ohms 200 watt—60,000 ohm adjustable
- R₂— 250,000 ohms 1 watt
- R₃— 5,000 ohms 5 watt
- R₄— 25,000 ohms 2 watts
- R₅— 26,500 ohms 200 watts—30,000 ohm adjustable
- R₆— 2,500 ohms 5 watts
- R₇— 750 ohms 5 watts
- RFC₁— 2.5 mhy. 125 ma. R-F choke
- RFC₂— 1 mhy. 500 ma. R-F choke
- T₁— 150 watt modulation transformer; ratio primary to secondary impedance approx. 1:1.1 Pri. impedance 15,000 ohms, sec. impedance 16,700 ohms.
- T₂— 5 watt driver transformer impedance ratio primary to 1/2 secondary 1.5:1.
- T₃— 300 watt modulation transformer; impedance ratio pri. to sec. approx. 2.4:1; Pri. impedance=20,000 ohms, sec. impedance=8,333 ohms.

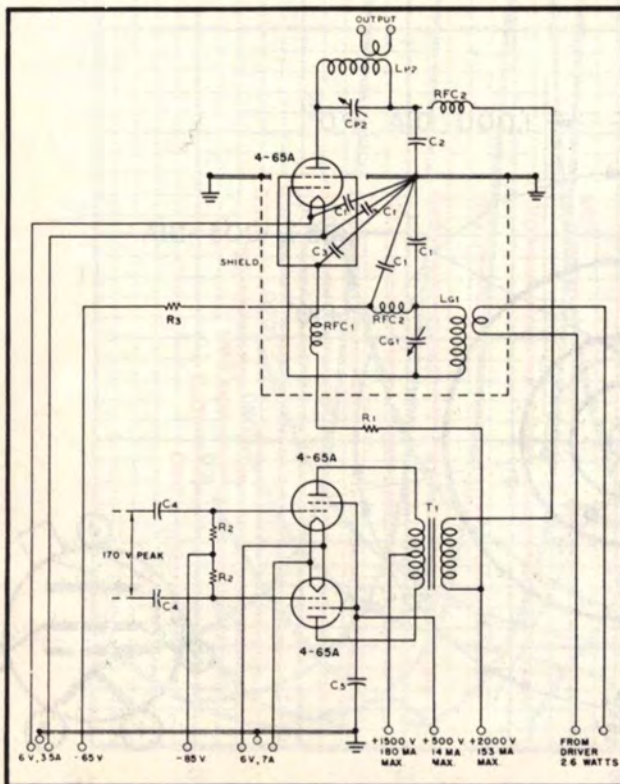

Typical high-level-modulated R-F amplifier, 240 watts plate input. Modulator requires zero driving power.

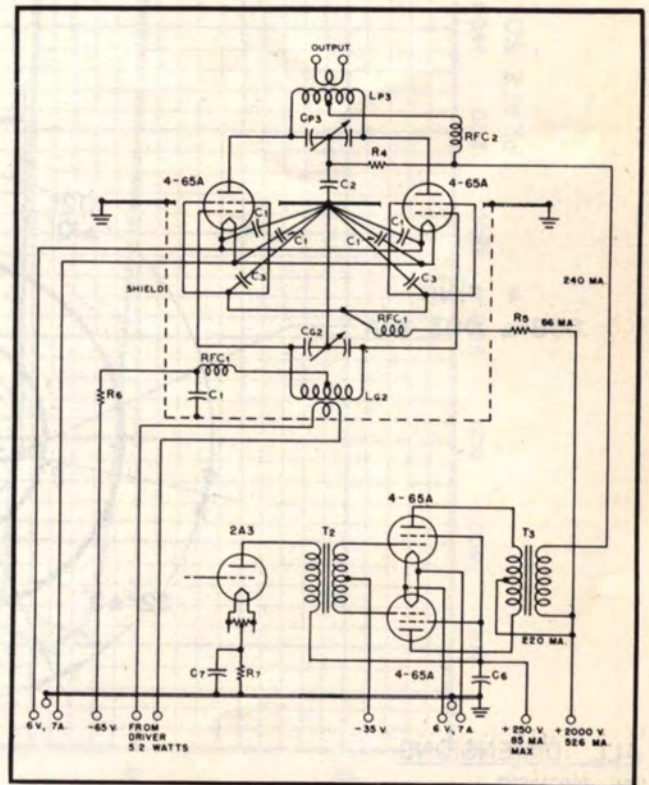

Typical high-level-modulated R-F amplifier circuit, with modulator and driver stages, 480 watts plate input.

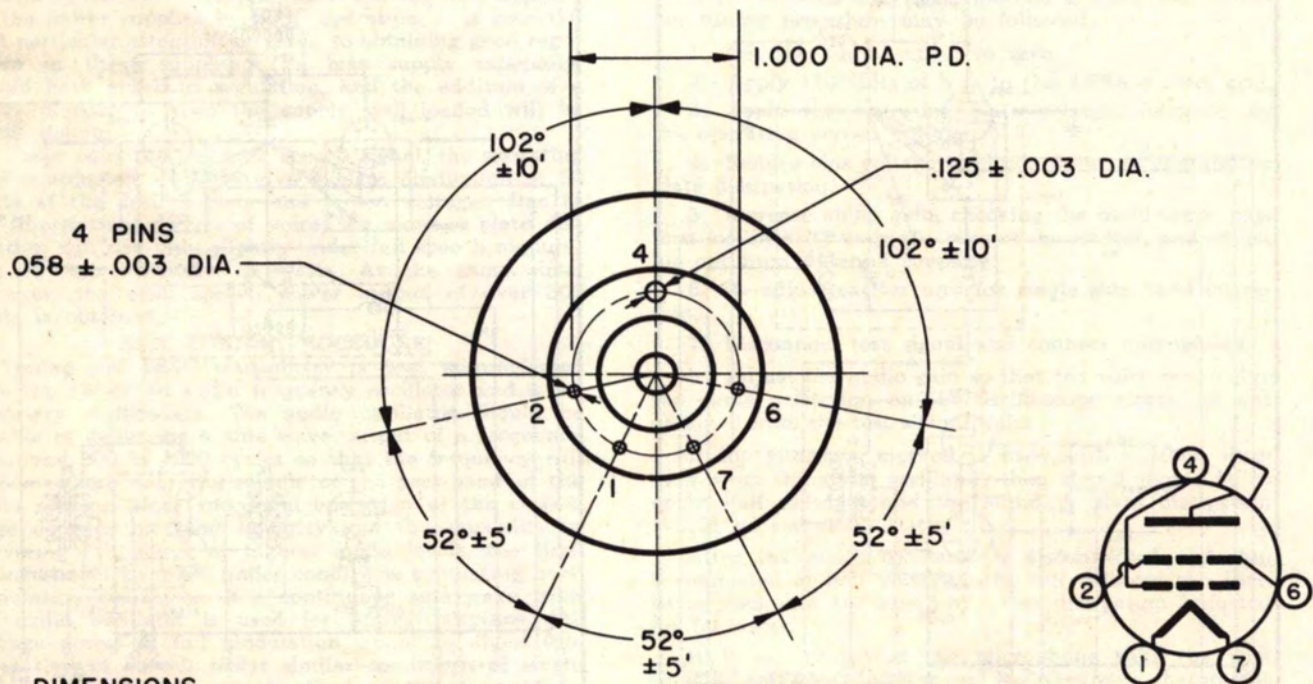
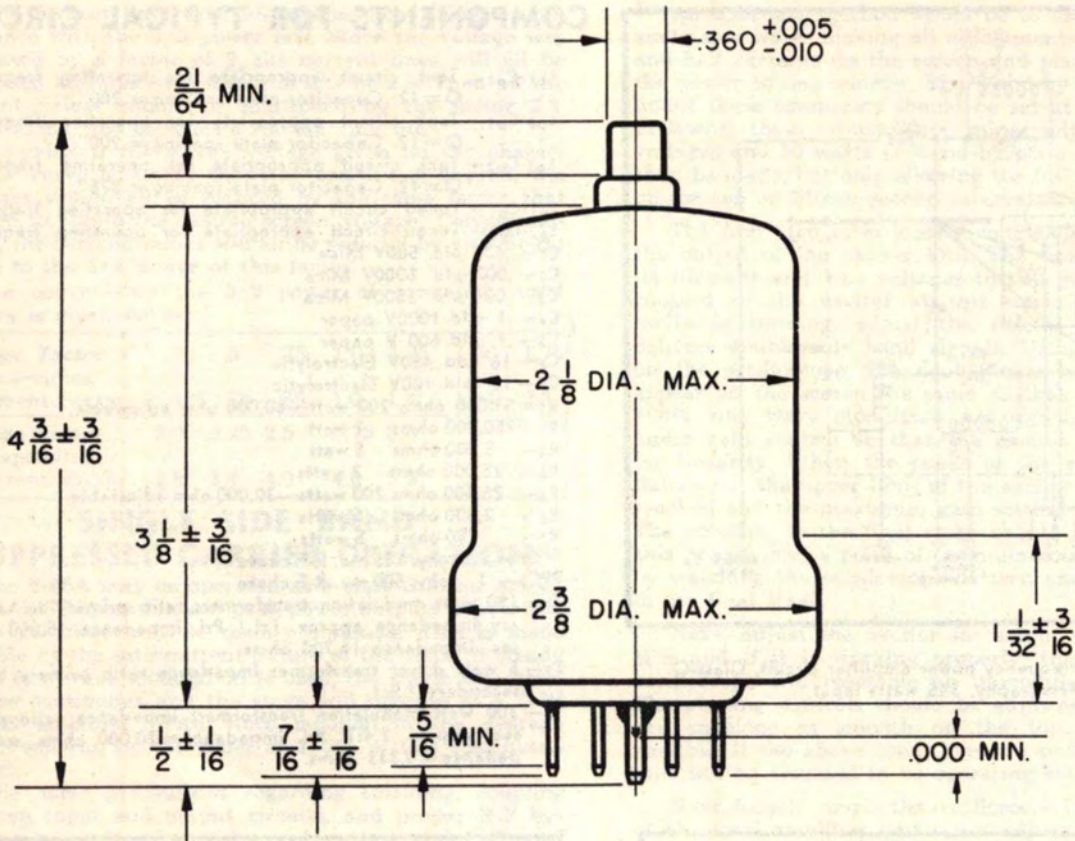

**ALL DIMENSIONS
 IN INCHES**

BOTTOM VIEW

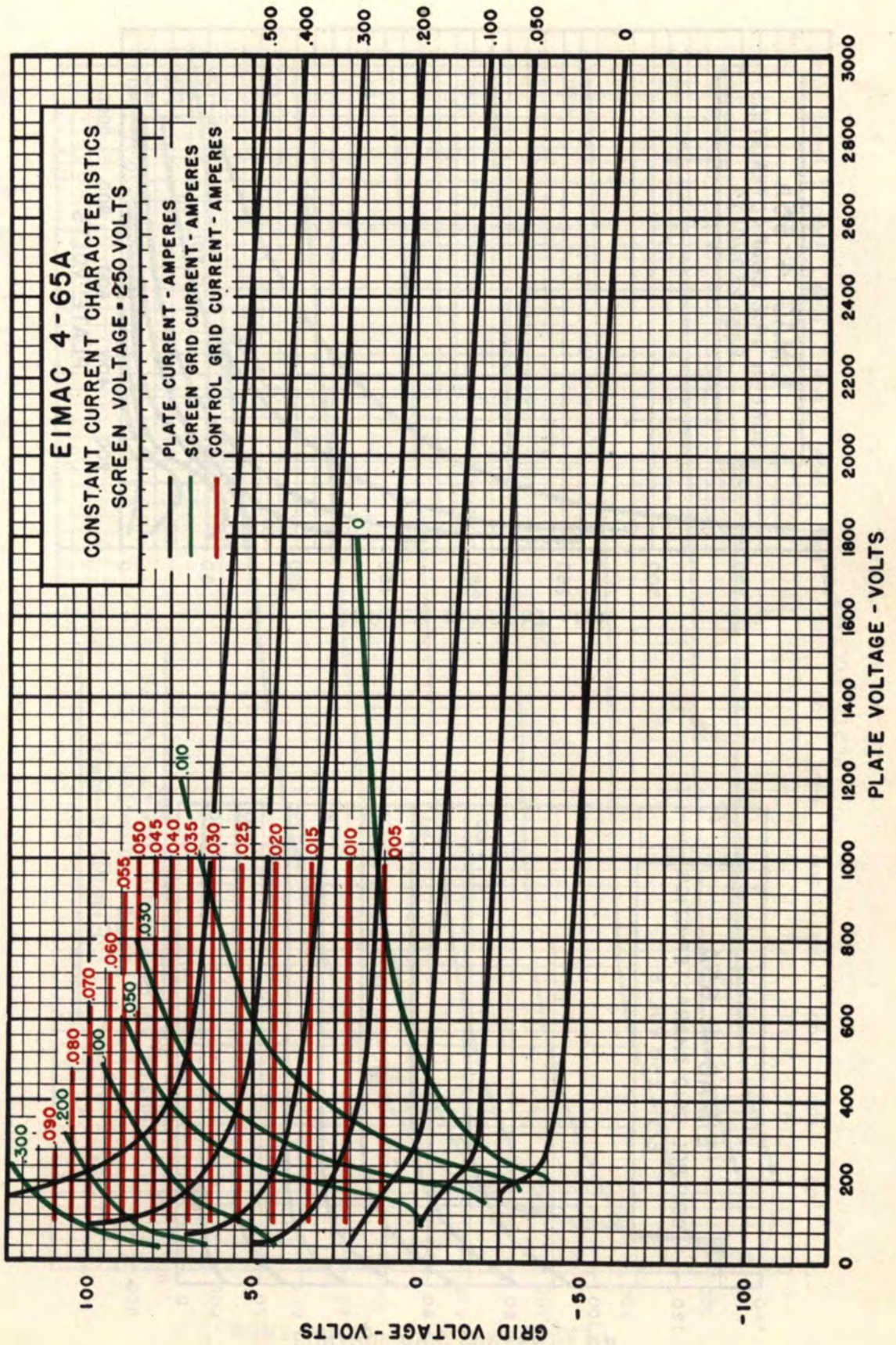

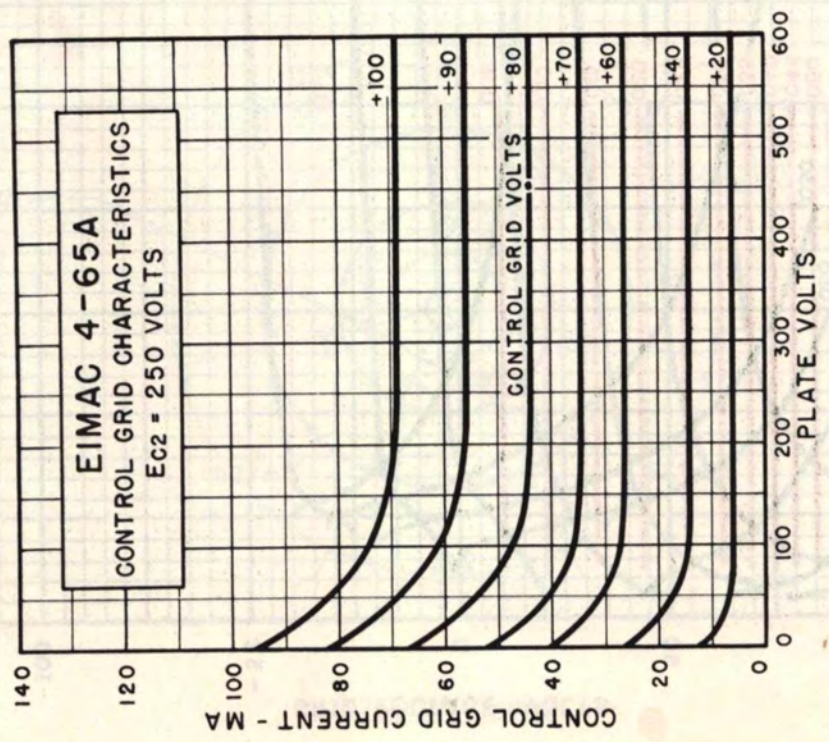
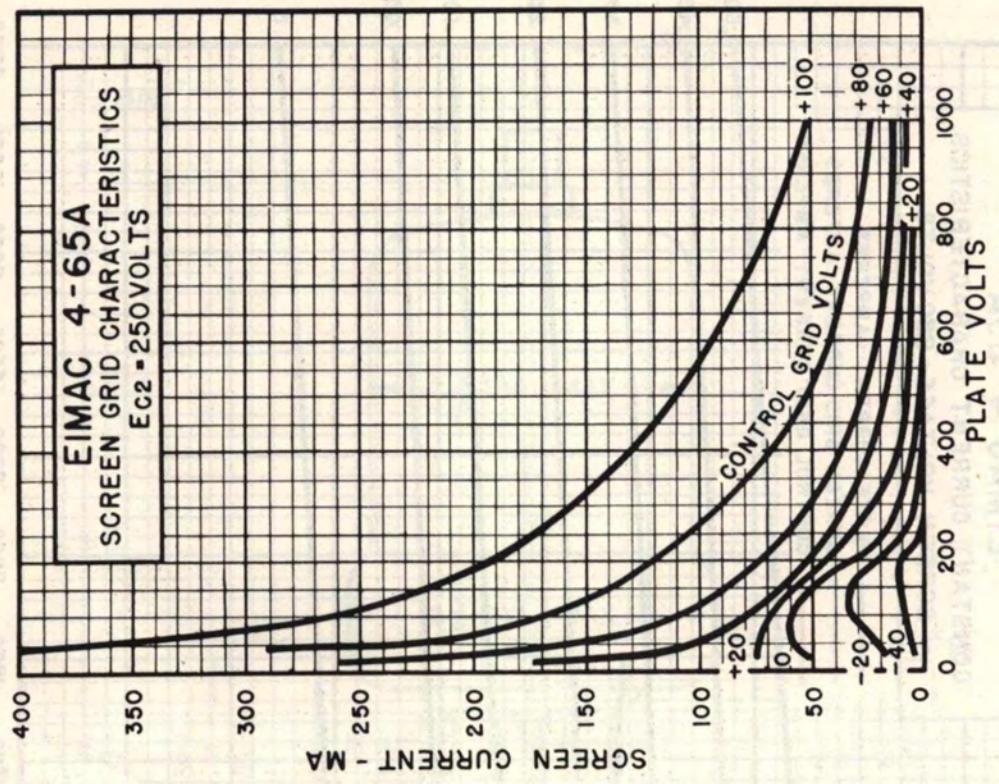

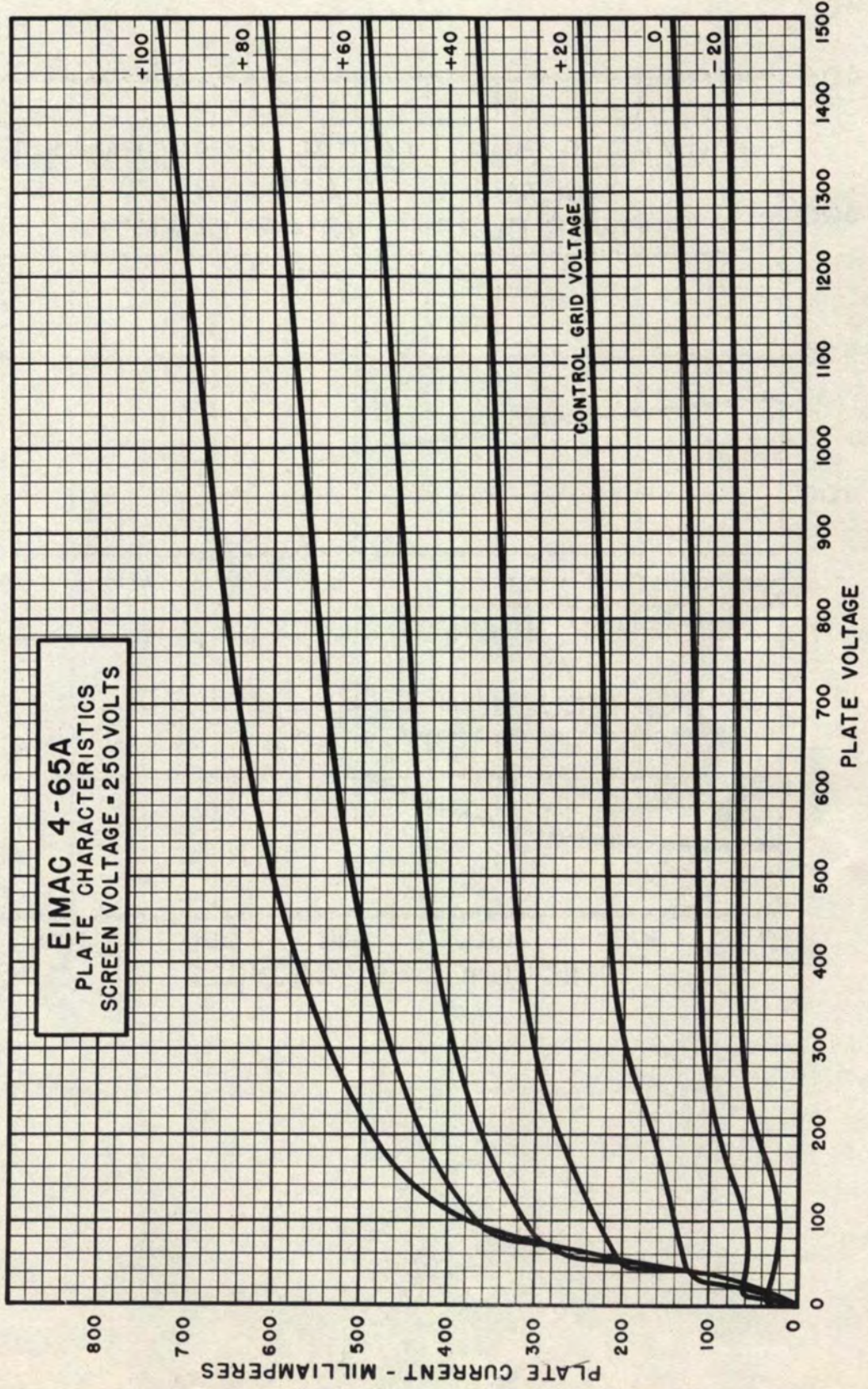

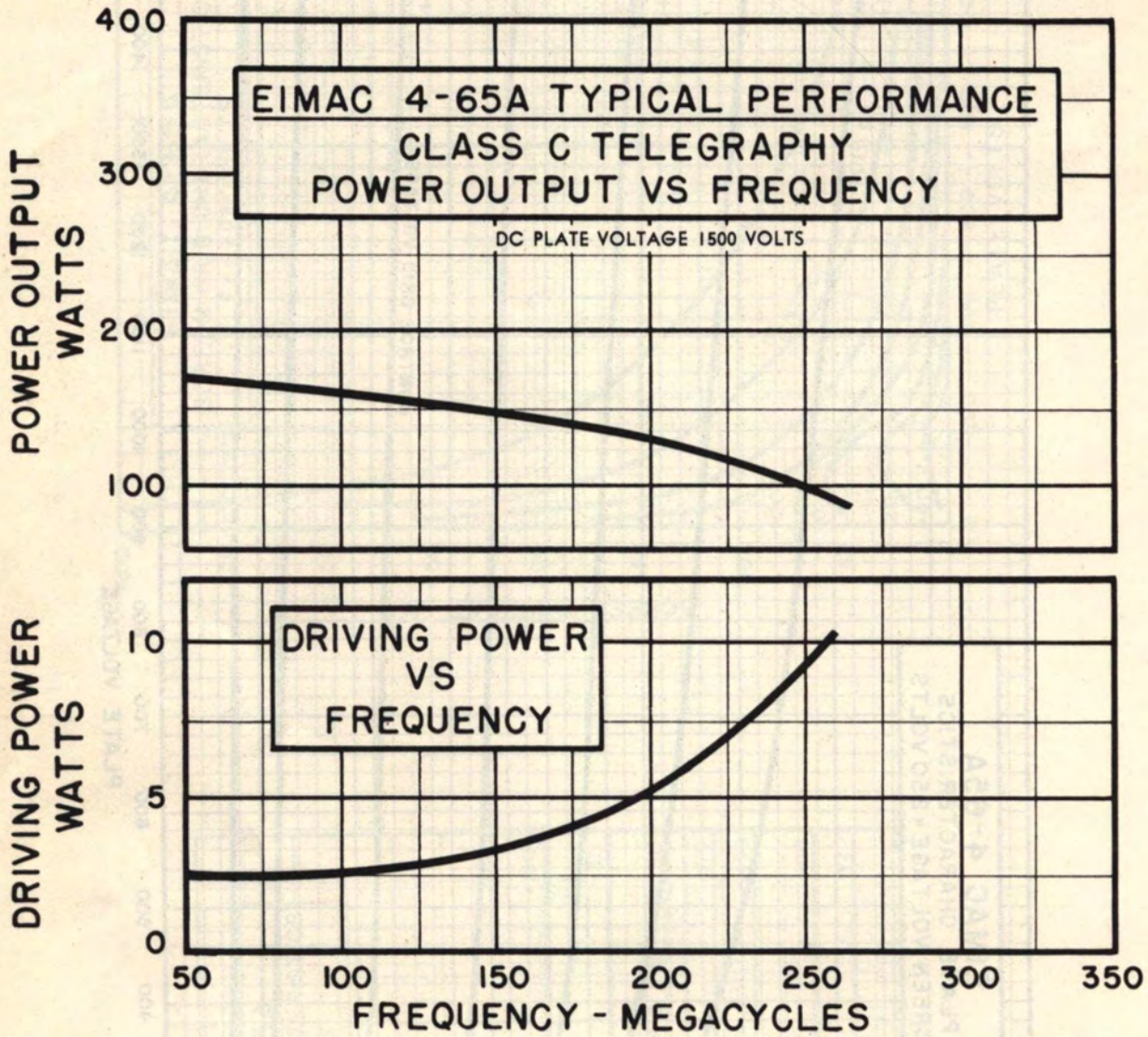

Eitel-McCULLOUGH, Inc.

SAN BRUNO, CALIFORNIA

4-125A

(4D21)
RADIAL-BEAM
POWER TETRODE

MODULATOR
OSCILLATOR
AMPLIFIER

► The Eimac 4-125A is a radial-beam power tetrode intended for use as an amplifier, oscillator, or modulator. It has a maximum plate-dissipation rating of 125 watts and a maximum plate-voltage rating of 3000 volts at frequencies up to 120 Mc.

The low grid-plate capacitance of this tetrode together with its low driving-power requirement allows considerable simplification of the associated circuit and driver stage.

Cooling is by radiation from the plate and by air circulation through the base and around the envelope.

The 4-125A in class-C r-f service will deliver up to 375 watts plate power output with 2.5 watts driving power. Two 4-125A's in class-B modulator service will deliver up to 400 watts maximum-signal power output with 1.2 watts nominal driving power.

GENERAL CHARACTERISTICS

ELECTRICAL

Filament: Thoriated Tungsten	
Voltage	5.0 volts
Current	6.5 amperes
Grid-Screen Amplification Factor (Average)	5.9
Direct Interelectrode Capacitances (Average)	
Grid-Plate	0.05 μmfd
Input	10.8 μmfd
Output	3.1 μmfd
Transconductance ($I_b = 50 \text{ ma.}, E_b = 2500\text{V.}, E_{c2} = 400\text{V.}$)	2450 μmhos
► Highest Frequency for Maximum Ratings	120 Mc

MECHANICAL

Base	5-pin metal shell
Basing	See outline drawing
Socket	E. F. Johnson Co. socket No. 122-275, National Co. No. HX-100, or equivalent
Mounting Position	Vertical, base down or up
Cooling	Radiation and forced air
Recommended Heat-Dissipating Plate Connector	Eimac HR-6
Maximum Over-all Dimensions:	
Length	5.69 inches
Diameter	2.75 inches
Net Weight	6.5 ounces
Shipping Weight (Average)	1.5 pounds

Note: Typical operation data are based on conditions of adjusting to a specified plate current, maintaining fixed conditions of grid bias, screen voltage, and r-f grid voltage. It will be found that if this procedure is followed, there will be little variation in power output between tubes even though there may be some variations in grid and screen currents. Where grid bias is obtained principally by means of a grid resistor, to control plate current it is necessary to make the resistor adjustable.

RADIO-FREQUENCY POWER AMPLIFIER AND OSCILLATOR

Class-C Telegraphy or FM Telephony (Key-down conditions, 1 tube)

MAXIMUM RATINGS

D-C PLATE VOLTAGE ¹	3000 MAX. VOLTS
D-C SCREEN VOLTAGE	400 MAX. VOLTS
D-C GRID VOLTAGE	-500 MAX. VOLTS
D-C PLATE CURRENT	225 MAX. MA
PLATE DISSIPATION	125 MAX. WATTS
SCREEN DISSIPATION	20 MAX. WATTS
GRID DISSIPATION	5 MAX. WATTS

HIGH-LEVEL MODULATED RADIO-FREQUENCY AMPLIFIER

Class-C Telephony (Carrier conditions unless otherwise specified, 1 tube)

MAXIMUM RATINGS

D-C PLATE VOLTAGE ¹	2500 MAX. VOLTS
D-C SCREEN VOLTAGE	400 MAX. VOLTS
D-C GRID VOLTAGE	-500 MAX. VOLTS
D-C PLATE CURRENT	200 MAX. MA
PLATE DISSIPATION	85 MAX. WATTS
SCREEN DISSIPATION	20 MAX. WATTS
GRID DISSIPATION	5 MAX. WATTS

TYPICAL OPERATION (Frequencies below 120 Mc.)

D-C Plate Voltage	2000	2500	3000	volts
D-C Screen Voltage	350	350	350	volts
D-C Grid Voltage	-100	-150	-150	volts
D-C Plate Current	200	200	167	ma
D-C Screen Current	50	40	30	ma
D-C Grid Current	12	12	9	ma
Screen Dissipation	18	14	10.5	watts
Grid Dissipation	1.6	2	1.2	watts
Peak R-F Grid Input Voltage (approx.)	230	320	280	volts
Driving Power (approx.) ²	2.8	3.8	2.5	watts
Plate Power Input	400	500	500	watts
Plate Dissipation	125	125	125	watts
Plate Power Output	275	375	375	watts

TYPICAL OPERATION (Frequencies below 120 Mc.)

D-C Plate Voltage	2000	2500	volts
D-C Screen Voltage	350	350	volts
D-C Grid Voltage	-220	-210	volts
D-C Plate Current	150	152	ma
D-C Screen Current	33	30	ma
D-C Grid Current	10	9	ma
Screen Dissipation	11.5	10.5	watts
Grid Dissipation	1.6	1.4	watts
Peak A-F Screen Voltage, 100% Modulation	210	210	volts
Peak R-F Grid Input Voltage (approx.)	375	360	volts
Driving Power (approx.) ²	3.8	3.3	watts
Plate Power Input	300	380	watts
Plate Dissipation	75	80	watts
Plate Power Output	225	300	watts

¹ Indicates change from sheet dated 3-15-50 (Effective 1-5-53) Copyright, 1953 by Eitel-McCullough, Inc.

² Above 120 Mc. the maximum plate voltage rating depends upon frequency. See page 4.



AUDIO-FREQUENCY POWER AMPLIFIER AND MODULATOR

Class-AB₁.

MAXIMUM RATINGS

D-C PLATE VOLTAGE	- - - - -	3000 MAX. VOLTS
D-C SCREEN VOLTAGE	- - - - -	600 MAX. VOLTS
MAX-SIGNAL D-C PLATE CURRENT, PER TUBE	- - - - -	225 MAX. MA
PLATE DISSIPATION, PER TUBE	- - - - -	125 MAX. WATTS
SCREEN DISSIPATION, PER TUBE	- - - - -	20 MAX. WATTS

AUDIO-FREQUENCY POWER AMPLIFIER AND MODULATOR

Class-AB₂.

MAXIMUM RATINGS

D-C PLATE VOLTAGE	- - - - -	3000 MAX. VOLTS
D-C SCREEN VOLTAGE	- - - - -	400 MAX. VOLTS
MAX-SIGNAL D-C PLATE CURRENT, PER TUBE	- - - - -	225 MAX. MA
PLATE DISSIPATION, PER TUBE	- - - - -	125 MAX. WATTS
SCREEN DISSIPATION, PER TUBE	- - - - -	20 MAX. WATTS

TYPICAL OPERATION (Sinusoidal wave, two tubes unless otherwise specified)

D-C Plate Voltage	- - - - -	1500	2000	2500	volts
D-C Screen Voltage	- - - - -	600	600	600	volts
D-C Grid Voltage ²	- - - - -	-90	-94	-96	volts
Zero-Signal D-C Plate Current	- - - - -	60	50	50	ma
Max-Signal D-C Plate Current	- - - - -	222	240	232	ma
Zero-Signal D-C Screen Current	- - - - -	-1.0	-0.5	-0.3	ma
Max-Signal D-C Screen Current	- - - - -	17	6.4	8.5	ma
Effective Load, Plate-to-Plate	- - - - -	10,200	13,400	20,300	ohms
Peak, A-F Grid Input Voltage (per tube)	- - - - -	90	94	96	volts
Driving Power	- - - - -	0	0	0	watt
Max-Signal Plate Dissipation (per tube)	- - - - -	87.5	125	125	watts
Max-Signal Plate Power Output	- - - - -	158	230	330	watts
Total Harmonic Distortion	- - - - -	5	2	2.6	per ct

TYPICAL OPERATION (Sinusoidal wave, two tubes unless otherwise specified)

D-C Plate Voltage	- - - - -	1500	2000	2500	volts
D-C Screen Voltage	- - - - -	350	350	350	volts
D-C Grid Voltage	- - - - -	-41	-45	-43	volts
Zero-Signal D-C Plate Current	- - - - -	87	72	93	ma
Max-Signal D-C Plate Current	- - - - -	400	300	260	ma
Zero-Signal D-C Screen Current	- - - - -	0	0	0	ma
Max-Signal D-C Screen Current	- - - - -	34	5	6	ma
Effective Load, Plate-to-Plate	- - - - -	7200	13,600	22,200	ohms
Peak A-F Grid Input Voltage (per tube)	- - - - -	141	105	89	volts
Max-Signal Avg. Driving Power (approx.)	- - - - -	2.5	1.4	1	watts
Max-Signal Peak Driving Power	- - - - -	5.2	3.1	2.4	watts
Max-Signal Plate Dissipation (per tube)	- - - - -	125	125	122	watts
Max-Signal Plate Power Output	- - - - -	350	350	400	watts
Total Harmonic Distortion	- - - - -	2.5	1	2.2	per ct

² The effective grid circuit resistance for each tube must not exceed 250,000 ohms.
³ Driving power increases above 70 Mc. See page 4.

IF IT IS DESIRED TO OPERATE THIS TUBE UNDER CONDITIONS WIDELY DIFFERENT FROM THOSE GIVEN UNDER "TYPICAL OPERATION," POSSIBLY EXCEEDING THE MAXIMUM RATINGS GIVEN FOR CW SERVICE, WRITE EITEL-McCULLOUGH, INC., FOR INFORMATION AND RECOMMENDATIONS.

APPLICATION

MECHANICAL

► **Mounting**—The 4-125A must be mounted vertically, base down or base up. The socket must be constructed so as to allow an unimpeded flow of air through the holes in the base of the tube and must also provide clearance for the glass tip-off which extends from the center of the base. The tube should be mounted above the chassis deck to allow free circulation of air in the manner shown in the mounting diagram below. The above requirements are met by the E. F. Johnson Co. socket No. 122-275, the National Co. socket No. HX-100, or a similar socket.

A flexible connecting strap should be provided between the HR-6 Heat Dissipating Plate Connector on the plate terminal and the external circuit. The tube must be protected from severe vibration and shock.

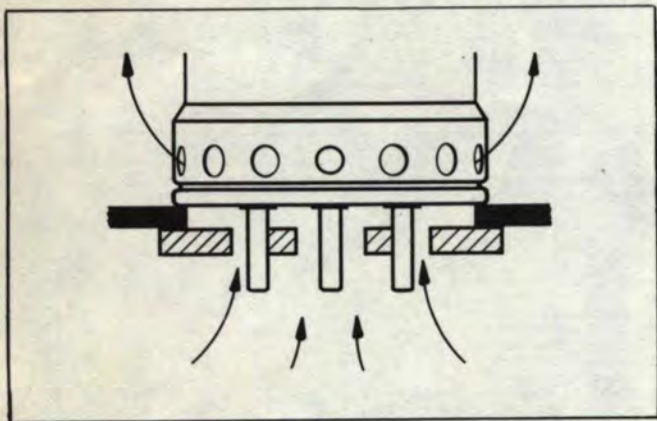

4-125A mounting providing base cooling, shielding and isolation of output and input compartments.

Cooling—Adequate cooling must be provided for the seals and envelope of the 4-125A. In continuous-service applications, the temperature of the plate seal, as measured on the top of the plate cap, should not exceed 170° C. A relatively slow movement of air past the tube is sufficient to prevent seal temperatures in excess of maximum at frequencies below 30 Mc. At frequencies above 30 Mc., radio-frequency losses in the leads and envelope contribute to seal and envelope heating, and special attention should be given to cooling. A small fan or centrifugal blower directed toward the upper portion of the envelope will usually provide sufficient circulation for cooling at frequencies above 30 Mc., however.

► Indicates change from sheet dated 3-15-50

In intermittent-service applications where the "on" time does not exceed a total of five minutes in any ten-minute period, plate seal temperatures as high as 220° C. are permissible. When the ambient temperature does not exceed 30° C. it will not ordinarily be necessary to provide forced cooling to hold the temperature below this maximum at frequencies below 30 Mc., provided that a heat-dissipating plate connector is used, and the tube is so located that normal circulation of air past the envelope is not impeded.

Provision must be made for circulation of air through the base of the tube. Where shielding or socket design makes it impossible to allow free circulation of air through the base, it will be necessary to apply forced-air cooling to the stem structure. An air flow of two cubic feet per minute through the base will be sufficient for stem cooling.

ELECTRICAL

Filament Voltage—For maximum tube life the filament voltage, as measured directly at the filament pins, should be the rated value of 5.0 volts. Unavoidable variations in filament voltage must be kept within the range from 4.75 to 5.25 volts.

Bias Voltage—D-c bias voltage for the 4-125A should not exceed 500 volts. If grid-leak bias is used, suitable protective means must be provided to prevent excessive plate or screen dissipation in the event of loss of excitation.

Screen Voltage—The d-c screen voltage for the 4-125A should not exceed 400 volts, except for class-AB₁ audio operation.

Plate Voltage—The plate-supply voltage for the 4-125A should not exceed 3000 volts for frequencies below 120 Mc. The maximum permissible plate voltage is less than 3000 volts above 120 Mc., as shown by the graph on page 4.

Grid Dissipation—Grid dissipation for the 4-125A should not be allowed to exceed five watts. Grid dissipation may be calculated from the following expression:

$$P_g = e_{cmp} I_c$$

where P_g = Grid dissipation,
 e_{cmp} = Peak positive grid voltage, and
 I_c = D-c grid current.

e_{cmp} may be measured by means of a suitable peak voltmeter connected between filament and grid⁴.

Screen Dissipation—The power dissipated by the screen of the 4-125A must not exceed 20 watts. Screen dissipation is likely to rise to excessive values when the plate voltage, bias voltage or plate load are removed with filament and screen voltages applied. Suitable protective means must be provided to limit screen dissipation to 20 watts in the event of circuit failure.

⁴ For suitable peak v.t.v.m. circuits see, for instance, "Vacuum Tube Ratings," Eimac News, January, 1945. This article is available in reprint form on request.

Plate Dissipation—Under normal operating conditions, the plate dissipation of the 4-125A should not be allowed to exceed 125 watts in unmodulated applications.

In high-level-modulated amplifier applications, the maximum allowable carrier-condition plate dissipation is 85 watts. The plate dissipation will rise to 125 watts under 100% sinusoidal modulation.

Plate dissipation in excess of the maximum rating is permissible for short periods of time, such as during tuning procedures.

OPERATION

Class-C Telegraphy or FM Telephony—The 4-125A may be operated as a class-C telegraph or FM telephone amplifier without neutralization up to about 30 Mc. If reasonable precautions are taken to prevent coupling between input and output circuits external to the tube. A grounded metallic plate on which the socket may be mounted as shown in the mounting diagram on page two provides an effective isolating shield between grid and plate circuits. In single-ended circuits, plate, grid, filament and screen by-pass capacitors should be returned through the shortest possible leads to a common chassis point. In push-pull applications the filament and screen terminals of each tube should be by-passed to a common chassis point by the shortest possible leads, and short, heavy leads should be used to interconnect the screens and filaments of the two tubes. Care should be taken to prevent leakage of radio-frequency energy to leads entering the amplifier, to prevent grid-plate coupling between these leads external to the amplifier.

Where shielding is adequate, the feed-back at frequencies above 100 Mc. is due principally to screen-lead-inductance effects, and it becomes necessary to introduce in-phase voltage from the plate circuit into the grid circuit. This can be done by adding capacitance between plate and grid external to the tube. Ordinarily, a small metal tab approximately 3/4-inch square connected to the grid terminal and located adjacent to the envelope opposite the plate will suffice for neutralization. Means should be provided for adjusting the spacing between the neutralizing capacitor plate and the envelope, but care must be taken to prevent the neutralizing plate from touching the envelope. An alternative neutralization scheme is illustrated in the diagram below. In this circuit feed-back is eliminated by series-tuning the screen to ground with a small capacitor. The socket screen terminals should be strapped together, as shown on the diagram, by the shortest possible lead, and the leads from the screen terminal to the capacitor, C, and from the capacitor to ground should be made as short as possible. All connections to the screen terminals should be made to the center of the strap between the terminals, in order to equalize the current in the two screen leads and prevent overheating one of them. The value for C given under the diagram presupposes the use of the shortest possible leads.

At frequencies below 100 Mc. ordinary neutralization systems may be used. With reasonably effective shielding, however, neutralization should not be required below about 30 Mc.

The driving power and power output under typical operating conditions, with maximum output and plate voltage, are shown on page 4. The power output shown is the actual plate power delivered by the tube; the power delivered to the load will depend upon the efficiency of the plate tank and output coupling system. The driving power is likewise the driving power required by the tube (includes bias loss). The driver output power should exceed the driving power requirement by a sufficient margin to allow for coupling-circuit losses. These losses will not ordinarily amount to more than 30 or 40 per cent of the driving power, except at frequencies above 150 Mc. The use of silver-plated linear tank-circuit elements is recommended at frequencies above 100 Mc.

Conventional capacitance-shortened quarter-wave linear grid tank circuits

having a calculated Z_0 of 160 ohms or less may be used with the 4-125A up to 175 Mc. Above 175 Mc. linear grid tank circuits employing a "capacitor"-type shorting bar, as illustrated in the diagram below, may be used. The capacitor, C₁, may consist of two silver-plated brass plates one inch square with a piece of .010-inch mica or polystyrene as insulation.

Class-C AM Telephony—The r-f circuit considerations discussed above under Class-C Telegraphy or FM Telephony also apply to amplitude-modulated operation of the 4-125A. When the 4-125A is used as a class-C high-level-modulated amplifier, modulation should be applied to both plate and screen. Modulation voltage for the screen may be obtained from a separate winding on the modulation transformer, by supplying the screen voltage via a series dropping resistor from the unmodulated plate supply, or by the use of an audio-frequency reactor in the positive screen-supply lead. When screen modulation is obtained by either the series-resistor or the audio-reactor method, the audio-frequency variations in screen current which result from variations in plate voltage as the plate is modulated automatically give the required screen modulation. Where a reactor is used, it should have a rated inductance of not less than 10 henries divided by the number of tubes in the modulated amplifier and a maximum current rating of two or three times the operating d-c screen current. To prevent phase shift between the screen and plate modulation voltages at high audio frequencies, the screen by-pass capacitor should be no larger than necessary for adequate r-f by-passing. Where screen voltage is obtained from a separate winding on the modulation transformer, the screen winding should be designed to deliver the peak screen modulation voltage given in the typical operating data on page 1.

For high-level modulated service, the use of partial grid-leak bias is recommended. Any by-pass capacitors placed across the grid-leak resistance should have a reactance at the highest modulation frequency equal to at least twice the grid-leak resistance.

Class-AB₁ and Class-AB₂ Audio—Two 4-125A's may be used in a push-pull circuit to give relatively high audio output power at low distortion. Maximum ratings and typical operating conditions for class-AB₁ and class-AB₂ audio operation are given in the tabulated data.

When type 4-125A tubes are used as class-AB₁ or class-AB₂ audio amplifiers at 1500 plate volts, under the conditions given under "Typical Operation," the screen voltage must be obtained from a source having reasonably good regulation, to prevent variations in screen voltage from zero-signal to maximum-signal conditions. The use of voltage regulator tubes in a standard circuit will provide adequate regulation. The variation in screen current at plate voltages of 2000 and above is low enough so that any screen power supply having a normal order of regulation will serve. The driver plate supply makes a convenient source of screen voltage under these conditions.

Grid bias voltage for class-AB₂ service may be obtained from batteries or from a small fixed-bias supply. When a bias supply is used, the d-c resistance of the bias source should not exceed 250 ohms. Under class-AB₁ conditions the effective grid-circuit resistance for each tube should not exceed 250,000 ohms.

The peak driving power figures given in the class-AB₂ tabulated data are included to make possible an accurate determination of the required driver output power. The driving amplifier must be capable of supplying the peak driving power without distortion. The driver stage should, therefore, be capable of providing an undistorted average output equal to half the peak driving power requirement. A small amount of additional driver output should be provided to allow for losses in the coupling transformer.

The power output figures given in the tabulated data refer to the total power output from the amplifier tubes. The useful power output will be from 5 to 15 per cent less than the figures shown, due to losses in the output transformer.

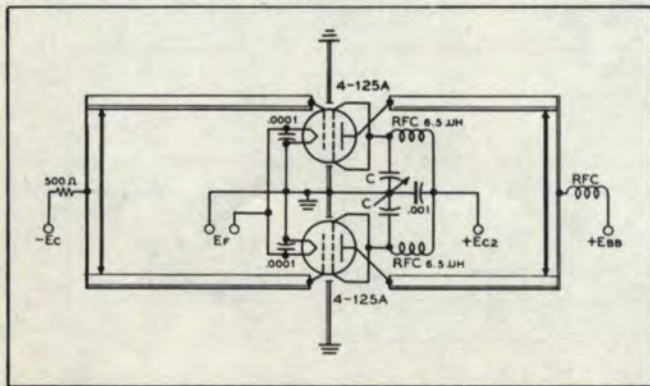

Screen-tuning neutralization circuit for use above 100 Mc. C is a small split-stator capacitor.

$$C(\mu\text{fd}) = \frac{640,000}{f^2 (\text{Mc.})}, \text{ approx.}$$

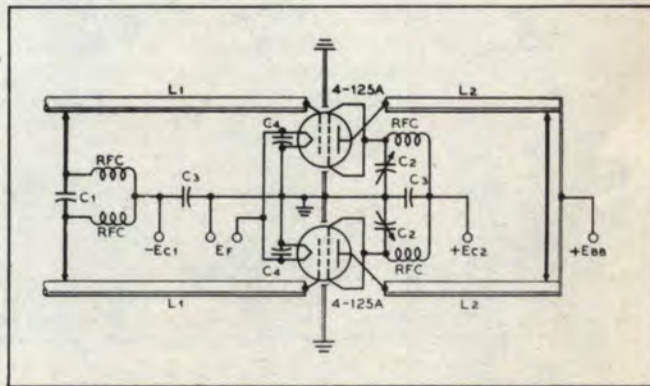

Typical circuit arrangement useful for frequencies above 175 Mc.

- C₁—See above.
- C₂—Neutralizing capacitor.
- C₃—.001μfd.
- C₄—100μμfd.
- L₁—3/8" dia. copper spaced, 1" center-to-center, 6" long.
- L₂—7/8" dia. brass, silver plated, spaced 1 1/2" center-to-center, 14" long.

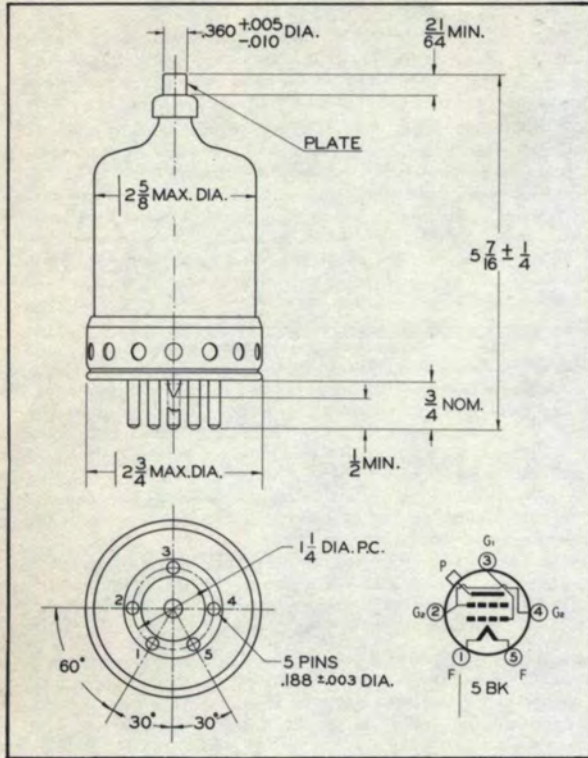

COMPONENTS FOR TYPICAL CIRCUITS

(Diagrams, Page 5)

- L_{p1}-C_{p1}—Tank circuit appropriate for operating frequency; Q = 12. Capacitor plate spacing = .200".
- L_{p2}-C_{p2}—Tank circuit appropriate for operating frequency; Q = 12. Capacitor plate spacing = .200".
- L_{p3}-C_{p3}—Tank circuit appropriate for operating frequency; Q = 12. Capacitor plate spacing = .375".
- L_{p4}-C_{p4}—Tank circuit appropriate for operating frequency; Q = 12. Capacitor plate spacing = .375".
- L_{g1}-C_{g1}—Tuned circuit appropriate for operating frequency.
- L_{g2}-C_{g2}—Tuned circuit appropriate for operating frequency.
- C₁—.002- μ fd., 500-v. mica
- C₂—.002- μ fd., 5000-v. mica
- C₃—.001- μ fd., 2500-v. mica
- C₄—16- μ fd., 450-v. electrolytic
- C₅—10- μ fd., 25-v. electrolytic
- R₁—7000 ohms, 5 watts
- R₂—70,000 ohms, 100 watts
- R₃—3500 ohms, 5 watts
- R₄—35,000 ohms, 200 watts
- R₅—560 ohms, 1 watt
- R₆—25,000 ohms, 2 watts
- R₇—1500 ohms, 5 watts
- RFC₁—2.5-mhy., 125-ma. r-f choke
- RFC₂—1-mhy., 500-ma. r-f choke
- T₁—10-watt driver transformer; ratio pri. to 1/2 sec. approx. 2:1.
- T₂—200-watt modulation transformer; ratio pri. to sec. approx. 1:1; pri. impedance = 16,200 ohms, sec. impedance = 16,500 ohms.
- T₃—5-watt driver transformer; ratio pri. to 1/2 sec. approx. 1.1:1.
- T₄—400-watt modulation transformer; ratio pri. to sec. approx. 2.7:1; pri. impedance = 22,200 ohms, sec. impedance = 8300 ohms.

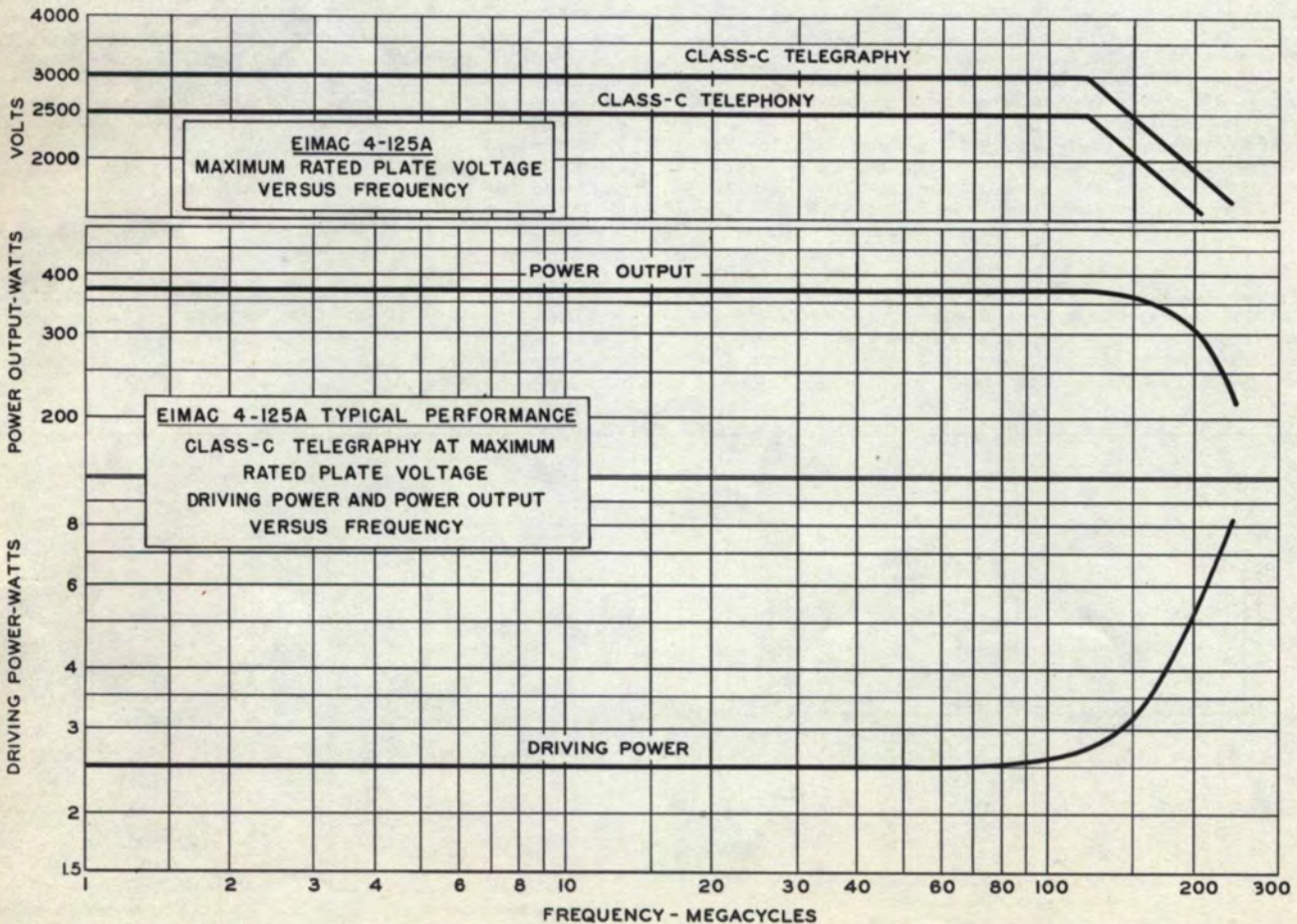

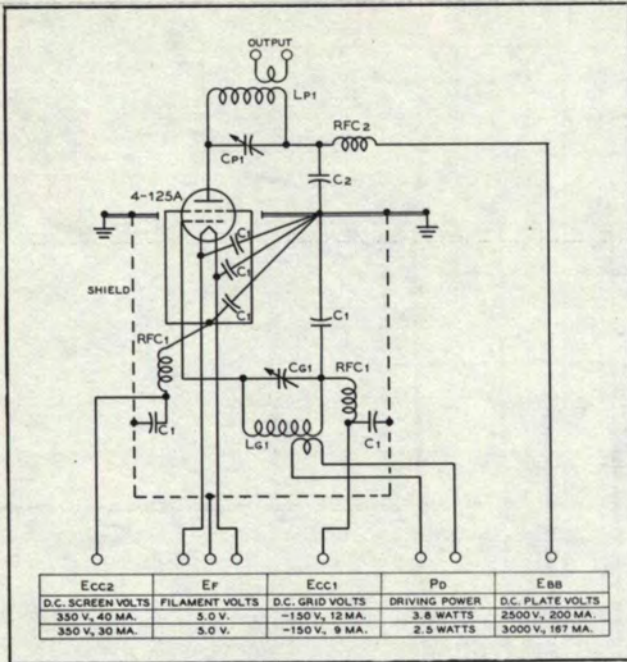

Typical radio-frequency power amplifier circuit, Class-C telegraphy, 500 watts input.

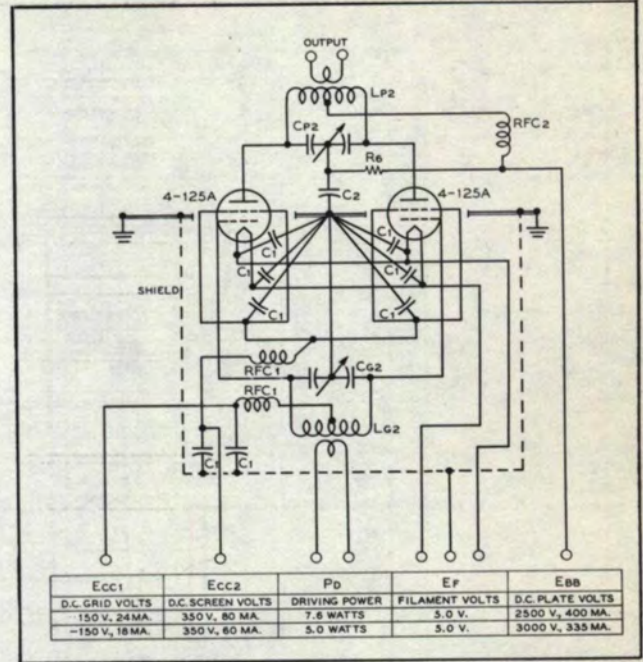

Typical radio-frequency power amplifier circuit, Class-C telegraphy, 1000 watts input.

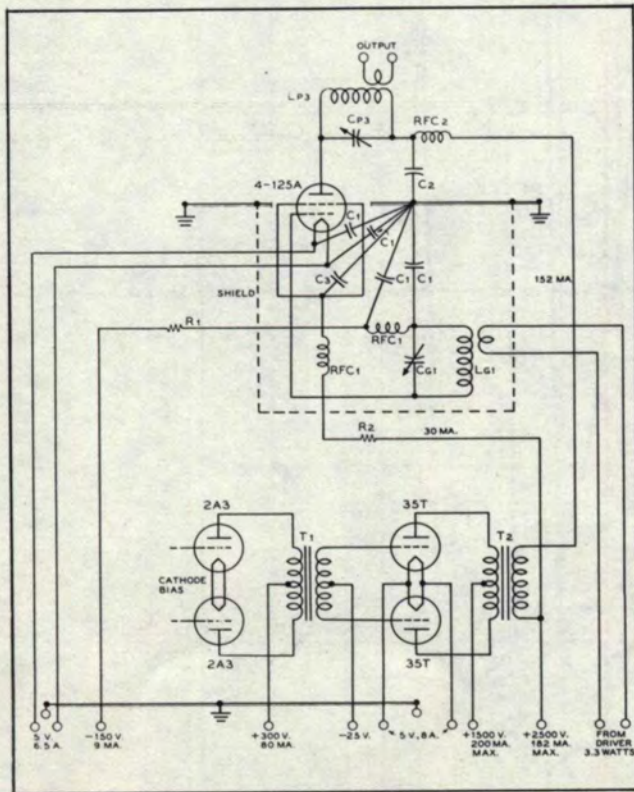

Typical high-level-modulated r-f amplifier circuit, with modulator and driver stages, 380 watts plate input.

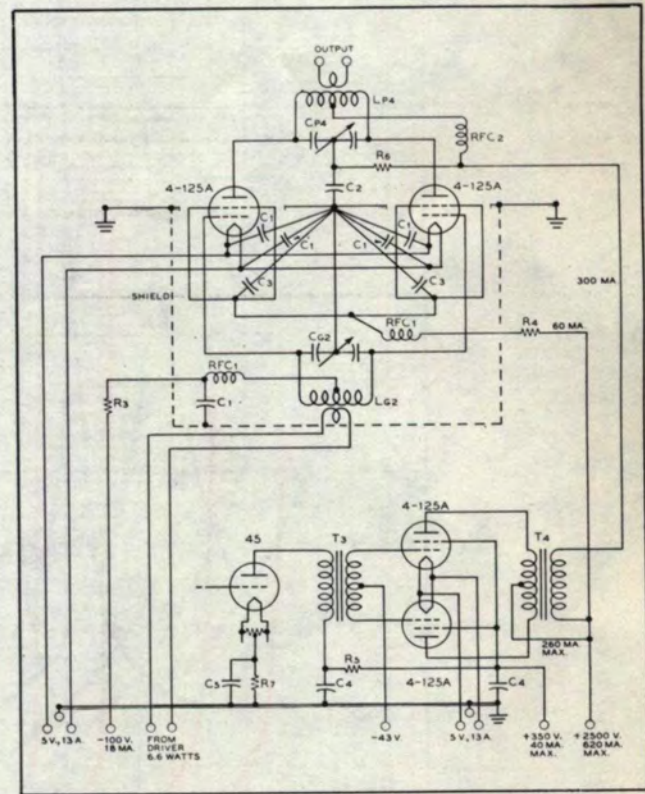

Typical high-level-modulated r-f amplifier circuit, with modulator and driver stages, 750 watts plate input.

SEE PRECEDING PAGE FOR LIST OF COMPONENTS

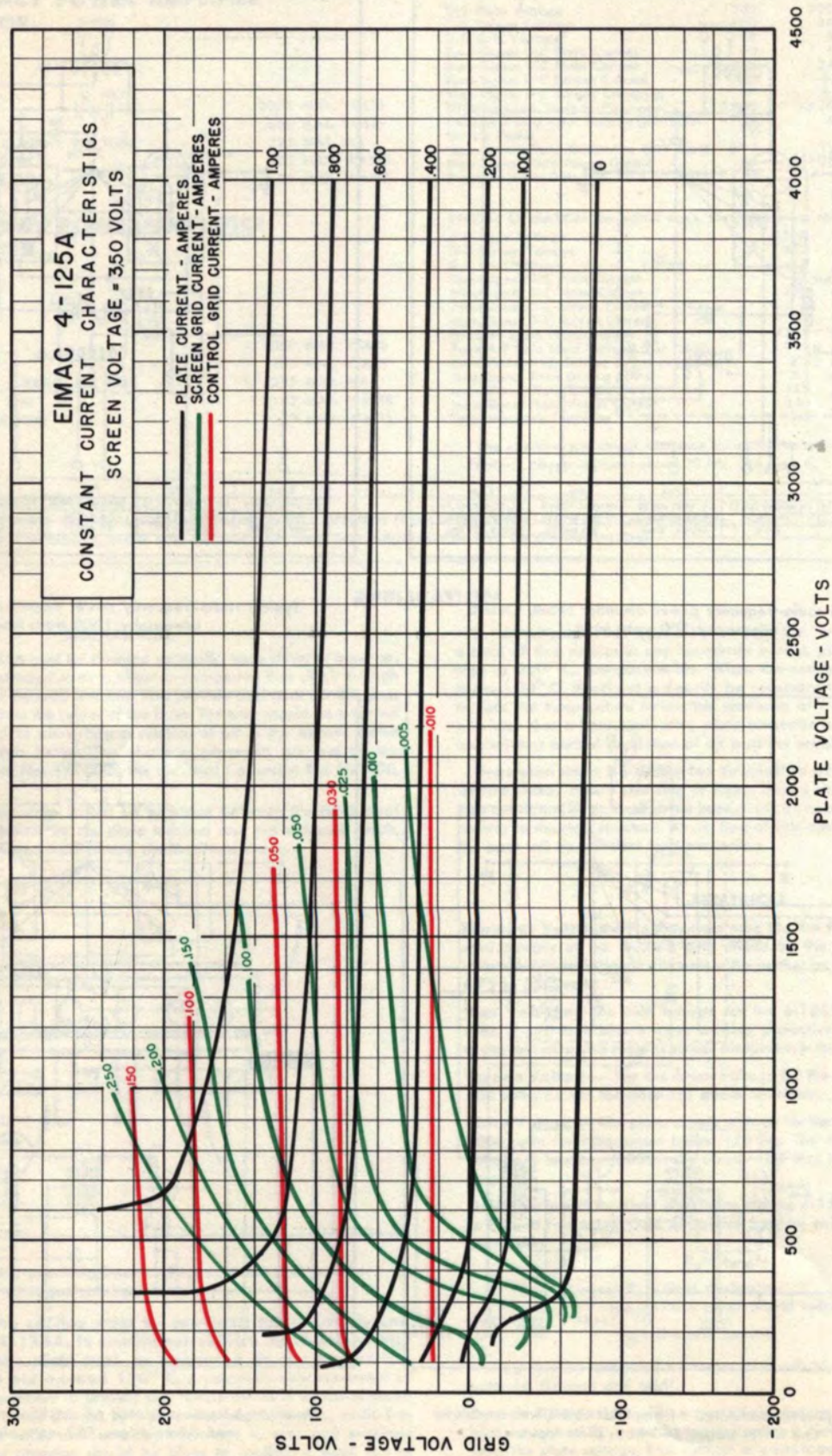

Eitel-McCullough, Inc.

SAN BRUNO, CALIFORNIA

4-250A

(5D22)
**RADIAL-BEAM
 POWER TETRODE**
 •
**MODULATOR
 OSCILLATOR
 AMPLIFIER**

The Eimac 4-250A is a compact, ruggedly constructed power tetrode having a maximum plate dissipation rating of 250 watts. It is intended for use as an amplifier, oscillator or modulator. The low grid-plate capacitance of this tetrode coupled with its low driving-power requirement allows considerable simplification of the associated circuit and driver stage.

The 4-250A is cooled by radiation from the plate and by circulation of forced-air through the base and around the envelope.

GENERAL CHARACTERISTICS

ELECTRICAL

Filament: Thoriated tungsten	
Voltage	5.0 volts
Current	14.5 amperes
Grid-Screen Amplification Factor (Average)	5.1
Direct Interelectrode Capacitances (Average)	
Grid-Plate	0.12 $\mu\mu\text{fd}$
Input	12.7 $\mu\mu\text{fd}$
Output	4.5 $\mu\mu\text{fd}$
Transconductance ($I_b=100 \text{ ma.}, E_b=2500\text{V.}, E_{c2}=500\text{V.}$)	4000 μmhos
Frequency for Maximum Ratings	75 Mc.

MECHANICAL

Base	5-pin metal shell
Recommended Socket	E. F. Johnson Co. socket No. 122-275, National Co. No. HX-100, or equivalent.
Basing	See drawing
Mounting Position	Vertical, base down or up
Cooling	Radiation and forced air
Recommended Heat Dissipating Plate Connector	Eimac HR-6
Maximum Overall Dimensions:	
Length	6.38 inches
Diameter	3.56 inches
Net Weight	8.0 ounces
Shipping Weight (Average)	2.0 pounds



Note: Typical operation data are based on conditions of adjusting to a specified plate current, maintaining fixed conditions of grid bias, screen voltage, and r-f grid voltage. It will be found that if this procedure is followed, there will be little variation in power output between tubes even though there may be some variation in grid and screen currents. Where grid bias is obtained principally by means of a grid resistor, to control plate current it is necessary to make the resistor adjustable.

RADIO-FREQUENCY POWER AMPLIFIER AND OSCILLATOR

Class-C FM or Telegraphy (Key-down conditions, 1 tube)

MAXIMUM RATINGS

D-C PLATE VOLTAGE ¹	4000 MAX. VOLTS
D-C SCREEN VOLTAGE	600 MAX. VOLTS
D-C GRID VOLTAGE	-500 MAX. VOLTS
D-C PLATE CURRENT	350 MAX. MA
PLATE DISSIPATION	250 MAX. WATTS
SCREEN DISSIPATION	35 MAX. WATTS
GRID DISSIPATION	10 MAX. WATTS

TYPICAL OPERATION (Frequencies below 75 Mc.)

D-C Plate Voltage	2500	3000	4000	volts
D-C Screen Voltage	500	500	500	volts
D-C Grid Voltage	-150	-180	-225	volts
D-C Plate Current	300	345	312	ma
D-C Screen Current	60	60	45	ma
D-C Grid Current	9	10	9	ma
Screen Dissipation	30	30	22.5	watts
Grid Dissipation	0.35	0.8	0.46	watts
Peak R-F Grid Input Voltage (approx.)	220	265	303	volts
Driving Power (approx.) ²	1.70	2.6	2.46	watts
Plate Power Input	750	1035	1250	watts
Plate Dissipation	175	235	250	watts
Plate Power Output	575	800	1000	watts

PLATE-MODULATED RADIO-FREQUENCY AMPLIFIER

Class-C Telephony

(Carrier conditions unless otherwise specified, 1 tube)

MAXIMUM RATINGS

D-C PLATE VOLTAGE ¹	3200 MAX. VOLTS
D-C SCREEN VOLTAGE	600 MAX. VOLTS
D-C GRID VOLTAGE	-500 MAX. VOLTS
D-C PLATE CURRENT	275 MAX. MA
PLATE DISSIPATION	165 MAX. WATTS
SCREEN DISSIPATION	35 MAX. WATTS
GRID DISSIPATION	10 MAX. WATTS

TYPICAL OPERATION (Frequencies below 75 Mc.)

D-C Plate Voltage	2500	3000	volts
D-C Screen Voltage	400	400	volts
D-C Grid Voltage	-200	-310	volts
D-C Plate Current	200	225	ma
D-C Screen Current	30	30	ma
D-C Grid Current	9	9	ma
Peak A-F Screen Voltage (100% modulation)	350	350	volts
Screen Dissipation	12	12	watts
Grid Dissipation	1.8	2.7	watts
Peak R-F Grid Input Voltage (approx.)	255	365	volts
Driving Power (approx.)	2.2	3.2	watts
Plate Power Input	500	675	watts
Plate Dissipation	125	165	watts
Plate Power Output	375	510	watts

¹Above 75 Mc. the maximum plate voltage rating depends upon frequency. See page four.

²Driving power increases above 40 Mc. See page four.

AUDIO-FREQUENCY POWER AMPLIFIER AND MODULATOR—CLASS AB

MAXIMUM RATINGS (PER TUBE)

D-C PLATE VOLTAGE	- - - - -	4000 MAX. VOLTS
D-C SCREEN VOLTAGE	- - - - -	600 MAX. VOLTS
MAX-SIGNAL D-C PLATE CURRENT	- - - - -	350 MAX. MA
PLATE DISSIPATION	- - - - -	250 MAX. WATTS
SCREEN DISSIPATION	- - - - -	35 MAX. WATTS
GRID DISSIPATION	- - - - -	10 MAX. WATTS

TYPICAL OPERATION CLASS AB₁

(Sinusoidal wave, two tubes unless otherwise specified)

D-C Plate Voltage	- - -	1500	2000	2500	3000	volts
D-C Screen Voltage	- - -	600	400	600	600	volts
D-C Grid Voltage ^{1,2}	- - -	-95	-104	-110	-116	volts
Zero-Signal D-C Plate Current	- - -	120	110	120	120	ma
Max-Signal D-C Plate Current	- - -	400	405	430	417	ma
Zero-Signal D-C Screen Current	- - -	-0.4	-0.3	-0.3	-0.2	ma
Max-Signal D-C Screen Current	- - -	23	22	13	10.5	ma
Effective Load, Plate-to-Plate	- - -	6250	9170	11,400	15,000	ohms
Peak A-F Grid Input Voltage	- - -					
(per tube)	- - -	64	88	90	93	volts
Driving Power	- - -	0	0	0	0	watts
Max-Signal Plate Dissipation	- - -					
(per tube)	- - -	145	175	225	250	watts
Max-Signal Plate Power Output	- - -	310	460	625	750	watts
Total Harmonic Distortion	- - -	4	2.5	2	2.5	per cent

¹Adjust for stated zero-signal plate current.
²The effective grid-circuit resistance must not exceed 250,000 ohms.

TYPICAL OPERATION CLASS AB₂

(Sinusoidal wave, two tubes unless otherwise specified)

D-C Plate Voltage	- - -	1500	2000	2500	3000	volts
D-C Screen Voltage	- - -	300	300	300	300	volts
D-C Grid Voltage ¹	- - -	-48	-48	-51	-53	volts
Zero-Signal D-C Plate Current	- - -	100	120	120	125	ma
Max-Signal D-C Plate Current	- - -	485	510	500	473	ma
Zero-Signal D-C Screen Current	- - -	0	0	0	0	ma
Max-Signal D-C Screen Current	- - -	34	26	23	33	ma
Effective Load, Plate-to-Plate	- - -	5400	8000	10,900	16,000	ohms
Peak A-F Grid Input Voltage	- - -					
(per tube)	- - -	96	99	100	99	volts
Max-Signal Avg. Driving Power	- - -					
(approx.)	- - -	2.1	2.3	2.2	1.9	watts
Max-Signal Peak Driving Power	- - -	4.7	5.5	4.8	4.6	watts
Max-Signal Plate Dissipation	- - -					
(per tube)	- - -	150	185	205	190	watts
Max-Signal Plate Power Output	- - -	428	650	840	1040	watts
Total Harmonic Distortion	- - -	3	4	4	4.5	per cent

IF IT IS DESIRED TO OPERATE THIS TUBE UNDER CONDITIONS WIDELY DIFFERENT FROM THOSE GIVEN UNDER "TYPICAL OPERATION", POSSIBLY EXCEEDING THE MAXIMUM RATINGS GIVEN FOR CW SERVICE, WRITE EITEL-McCULLOUGH, INC., FOR INFORMATION AND RECOMMENDATIONS.

APPLICATION

Mechanical

► **Mounting**—The 4-250A must be mounted vertically, base down or base up. The socket must be constructed so as to allow an unimpeded flow of air through the holes in the base of the tube and must also provide clearance for the glass tip-off which extends from the center of the base. The tube should be mounted above the chassis deck to allow free circulation of air in the manner shown in the mounting diagram below. The metal tube-base shell should be grounded by means of suitable spring fingers. The above requirements are met by the E. F. Johnson Co. socket No. 122-275, the National Co. socket No. HX-100, or a similar socket.

A flexible connecting strap should be provided between the HR-6 Heat Dissipating Plate Connector on the plate terminal and the external circuit. The tube must be protected from severe vibration and shock.

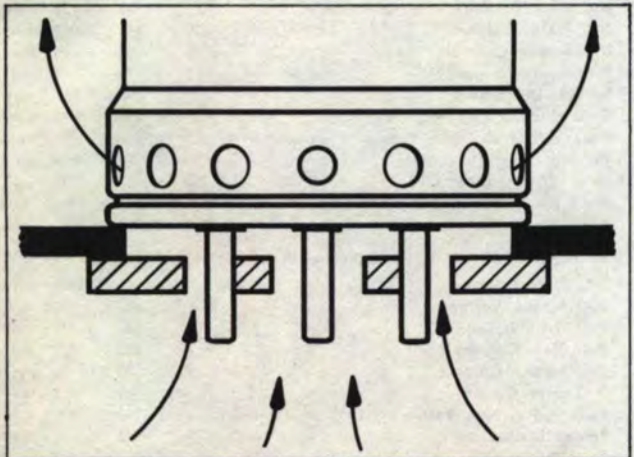

4-250A mounting providing base cooling, shielding and isolation of output and input compartments.

► Indicates change from sheet dated 7-1-51

Cooling—Adequate cooling must be provided for the seals and envelope of the 4-250A. Forced-air circulation in the amount of five cubic feet per minute through the base of the tube is required. This air should be applied simultaneously with filament power. The temperature of the plate seal, as measured on the top of the plate cap, should not exceed 170°C. in continuous-service applications.

A relatively slow movement of air past the tube is sufficient to prevent a plate seal temperature in excess of the maximum rating at frequencies below 30 Mc. At frequencies above 30 Mc., radio-frequency losses in the leads and envelope contribute to seal and envelope heating and special attention should be given to bulb and plate seal cooling. A small fan or centrifugal blower directed toward the upper portion of the envelope will usually provide sufficient circulation for cooling at frequencies above 30 Mc. [The Eimac 4-400A Air-System Socket provides a convenient method of mounting and cooling the 4-250A at VHF, should the user desire to use it. Full information is available on the 4-400A data sheet, or it will be sent from the factory on request.]

In intermittent-service applications where the "on" time does not exceed a total of five minutes in any ten-minute period, plate-seal temperatures as high as 220° C. are permissible. When the ambient temperature does not exceed 30° C. it will not ordinarily be necessary to provide forced cooling of the bulb and plate seal to hold the temperature below this maximum at frequencies below 30 Mc., provided that a heat-radiating plate connector is used, and the tube is so located that normal circulation of air past the envelope is not impeded.

Electrical

► **Filament Voltage**—For maximum tube life the filament voltage, as measured directly at the base pins, should be the rated value of 5.0 volts. Variations should be held within the range of 4.75 to 5.25 volts.

Bias Voltage—D-c bias voltage for the 4-250A should not exceed 500 volts. If grid-leak bias is used, suitable protective means must be provided to prevent excessive plate or screen dissipation in the event of loss of excitation.

Grid Dissipation—Grid dissipation for the 4-250A should not be allowed to exceed ten watts. Grid dissipation may be calculated from the following expression:

$$P_g = e_{emp} I_c$$

where P_g = Grid dissipation

e_{emp} = Peak positive grid voltage, and

I_c = D-c grid current.

e_{emp} may be measured by means of a suitable peak voltmeter connected between filament and grid*.

Screen Voltage—The d-c screen voltage for the 4-250A should not exceed 600 volts.

Screen Dissipation—The power dissipated by the screen of the 4-250A must not exceed 35 watts. Screen dissipation is likely to rise to excessive values when the plate voltage, bias voltage or plate load is removed with filament and screen voltages applied. Suitable protective means must be provided to limit screen dissipation to 35 watts in the event of circuit failure.

Plate Voltage—The plate-supply voltage for the 4-250A should not exceed 4000 volts for frequencies below 75 Mc. Above 75 Mc., the maximum permissible plate voltage is less than 4000 volts, as shown by the graph on page four.

Plate Dissipation—Under normal operating conditions, the plate dissipation of the 4-250A should not be allowed to exceed 250 watts in unmodulated applications.

In plate-modulated amplifier applications, the maximum allowable carrier-condition plate dissipation is 165 watts.

Plate dissipation in excess of the maximum rating is permissible for short periods of time, such as during tuning procedures.

Operation

Class-C FM or Telegraphy—The 4-250A may be operated as a class-C amplifier, FM or telegraphy, without neutralization up to 30 Mc. if reasonable precautions are taken to prevent coupling between input and output circuits external to the tube. A grounded metallic plate on which the socket may be mounted and to which suitable connectors may be attached to ground the tube base shell, provides an effective isolating shield between grid and plate circuits. In single-ended circuits, plate, grid, filament and screen by-pass capacitors should be returned through the shortest possible leads to a common chassis point. In push-pull applications the filament and screen terminals of each tube should be by-passed to a common chassis point by the shortest possible leads, and short, heavy leads should be used to interconnect the screens and filaments of the two tubes. Care should be taken to prevent leakage of radio-frequency energy to leads

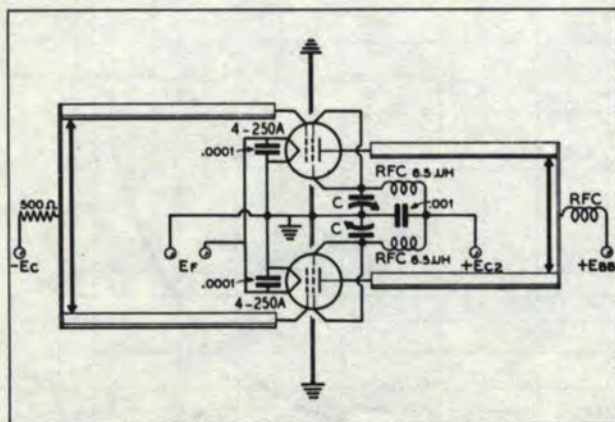

Screen-tuning neutralization circuit for use above 45 Mc.
 C — Approximately 100μμfd. per section, maximum.

entering the amplifier in order to minimize grid-plate coupling between these leads external to the amplifier.

At frequencies from 30 Mc. to 45 Mc. ordinary neutralization systems may be used.

Where shielding is adequate, the feed-back at frequencies above 45 Mc. is due principally to screen-lead-inductance effects, and it becomes necessary to introduce in-phase voltage from the plate circuit into the grid circuit. This can be done by adding capacitance between plate and grid external to the tube. Ordinarily, a small metal tab approximately 3/4-inch square connected to the grid terminal and located adjacent to the envelope opposite the plate will suffice for neutralization. Means should be provided for adjusting the spacing between the neutralizing capacitor plate and the envelope. An alternative neutralization scheme is illustrated in the diagram below. In this circuit, feed-back is eliminated by series-tuning the screen to ground with a small capacitor. The socket screen terminals should be strapped together, as shown on the diagram, by the shortest possible lead, and the leads from the screen terminal to the capacitor, C, and from the capacitor to ground should be made as short as possible.

Driving power and power output under maximum output and plate voltage conditions are shown on page 4. The power output shown is the actual plate power delivered by the tube; the power delivered to the load will depend upon the efficiency of the plate tank and output coupling system. The driving power is likewise the driving power required by the tube (includes bias loss). The driver output power should exceed the driving power requirement by a sufficient margin to allow for coupling-circuit losses. The use of silver-plated linear tank-circuit elements is recommended for all frequencies above 75 Mc.

Class-C AM Telephony—The r-f circuit considerations discussed above under Class-C FM or Telegraphy also apply to amplitude-modulated operation of the 4-250A. When the 4-250A is used as a class-C plate-modulated amplifier, modulation should be applied to both plate and screen. Modulation voltage for the screen may be obtained from a separate winding on the modulation transformer, by supplying the screen voltage via a series dropping resistor from the unmodulated plate supply, or by the use of an audio-frequency reactor in the positive screen-supply lead. When screen modulation is obtained by either the series-resistor or the audio-reactor method, the audio-frequency variations in screen current which result from the variations in plate voltage as the plate is modulated automatically give the required screen modulation. Where a reactor is used, it should have a rated inductance of not less than 10 henries divided by the number of tubes in the modulated amplifier and a maximum current rating of two or three times the operating d-c screen current. To prevent phase shift between the screen and plate modulation voltages at high audio frequencies, the screen by-pass capacitor should be no larger than necessary for adequate r-f by-passing.

For plate-modulated service, the use of partial grid-leak bias is recommended. Any by-pass capacitors placed across the grid-leak resistance should have a reactance at the highest modulation frequency equal to at least twice the grid-leak resistance.

Class-AB₁ and Class-AB₂ Audio—Two 4-250A's may be used in a push-pull circuit to give relatively high audio output power at low distortion. Maximum ratings and typical operating conditions for class-AB₁ and class-AB₂ audio operation are given in the tabulated data.

Screen voltage should be obtained from a source having reasonably good regulation to prevent variations in screen voltage from zero-signal to maximum-signal conditions. The use of voltage regulator tubes in a standard circuit should provide adequate regulation.

Grid bias voltage for class-AB₂ service may be obtained from batteries or from a small fixed-bias supply. When a bias supply is used the d-c resistance of the bias source should not exceed 250 ohms. Under class-AB₁ conditions the effective grid-circuit resistance should not exceed 250,000 ohms.

* For suitable peak v.t.v.m. circuits see, for instance, "Vacuum Tube Ratings," Eimac News, January, 1945. This article is available in reprint form on request.

The peak driving power figures given in the class-AB₂ tabulated data are included to make possible an accurate determination of the required driver output power. The driver amplifier must be capable of supplying the peak driving power without distortion. The driver stage should, therefore, be capable of providing an undistorted average output equal to half the peak driving power requirement. A small amount of additional driver output should be provided to allow for losses in the coupling transformer.

In some cases the maximum-signal plate dissipation shown under "Typical Operation" is less than the maximum rated plate dissipation of the 4-250A. In these cases, the plate dissipation reaches a maximum value, equal to the maximum rating, at a point somewhat below maximum-signal conditions.

The power output figures given in the tabulated data refer to the total power output from the amplifier tubes. The useful power output will be from 5 to 15 per cent less than the figures shown, due to losses in the output transformer.

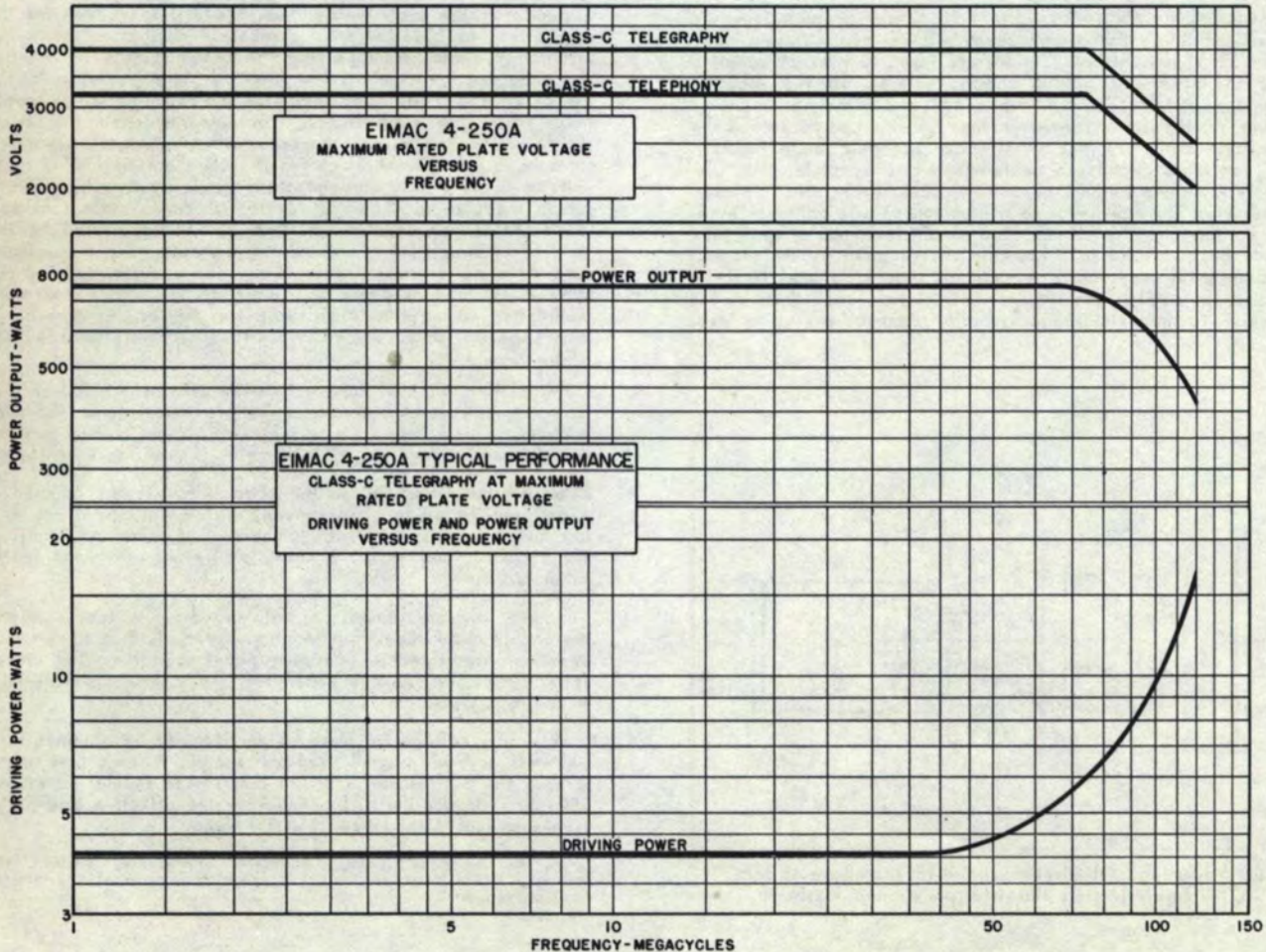
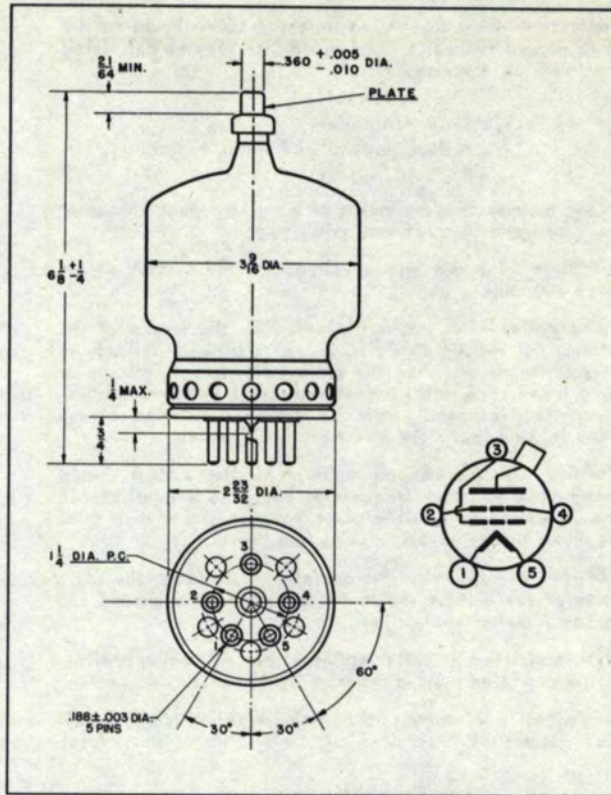

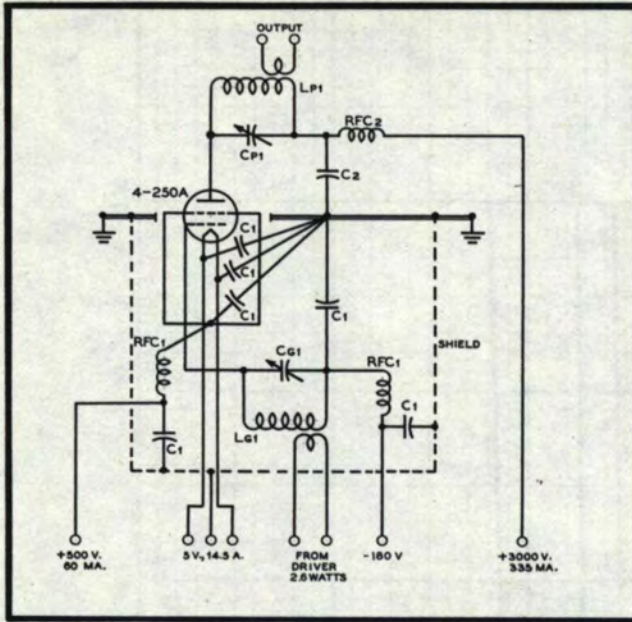

Typical radio frequency power amplifier circuit, Class-C telegraphy, 1000 watts input.

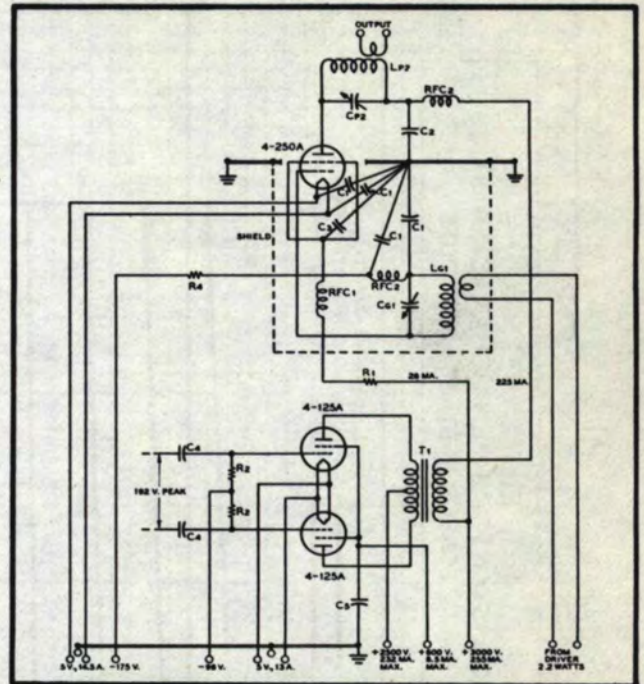

Typical high-level-modulated r-f amplifier circuit, with modulator stage, 675 watts input.

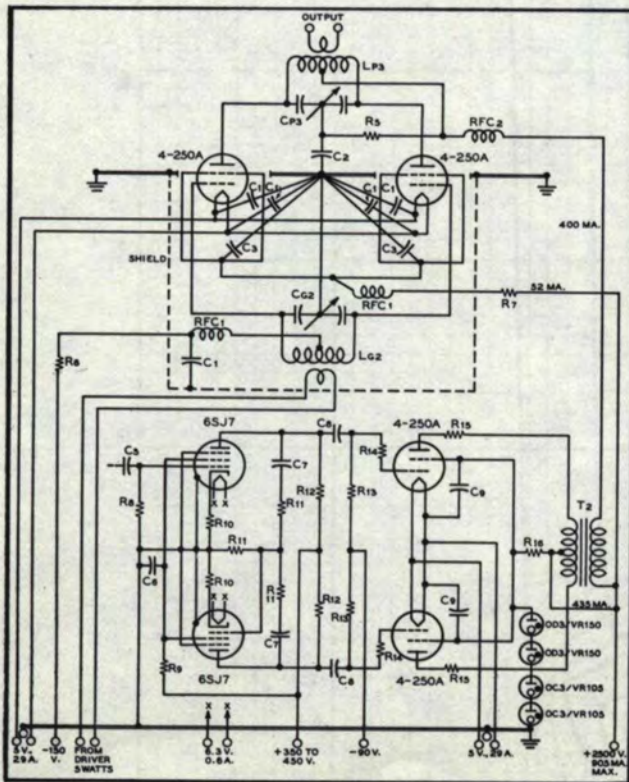

Typical high-level-modulated r-f amplifier circuit, with modulator and driver stages, 1000 watts input.

COMPONENTS FOR TYPICAL CIRCUITS

- L_{p1} - C_{p1} — Tank circuit appropriate for operating frequency; Q = 12. Capacitor plate spacing = .200".
- L_{p2} - C_{p2} — Tank circuit appropriate for operating frequency; Q = 12. Capacitor plate spacing = .200".
- L_{p3} - C_{p3} — Tank circuit appropriate for operating frequency; Q = 12. Capacitor plate spacing = .375".
- L_{m1} - C_{m1} — Tuned circuit appropriate for operating frequency.
- L_{m2} - C_{m2} — Tuned circuit appropriate for operating frequency.
- C₁ — .002-ufd., 500-v. mica
- C₂ — .002-ufd., 5000-v mica
- C₃ — .001-ufd., 2500-v. mica
- C₄ — .1-ufd., 1000-v. paper
- C₅ — .1-ufd., 600-v. paper
- C₆ — .5-ufd., 600-v. paper
- C₇ — .03-ufd., 600-v. paper
- C₈ — .1-ufd., 1000-v. paper
- C₉ — .25-ufd., 1000-v. paper
- R₁ — 86,700 ohms, adjustable 100,000 ohms, 100 watts
- R₂ — 250,000 ohms, 1/2 watt
- R₃ — 15,000 ohms, 5 watts
- R₄ — 25,000 ohms, 2 watts
- R₅ — 2,500 ohms, 5 watts
- R₇ — 35,000 ohms, 160 watts
- R₈ — 250,000 ohms, 1/2 watt
- R₉ — 200,000 ohms, 2 watts
- R₁₀ — 500 ohms, 1/2 watt
- R₁₁ — 1 megohm, 1/2 watt
- R₁₂ — 100,000 ohms, 1 watt
- R₁₃ — 200,000 ohms, 1/2 watt
- R₁₄ — 10,000 ohms, 1/2 watt
- R₁₅ — 50 ohms, 10 watts
- R₁₆ — 100,000 ohms, 100 watts
- RFC₁ — 2.5-mhy., 125-ma. r-f choke
- RFC₂ — 1-mhy., 500-ma. r-f choke
- T₁ — 350-watt modulation transformer; ratio pri. to sec. approx. 1.5 : 1; pri. impedance 20,300 ohms, sec. impedance 13,300 ohms.
- T₂ — 600-watt modulation transformer; ratio pri. to sec. approx. 1.8 : 1; pri. impedance 11,400 ohms, sec. impedance 6,250 ohms.

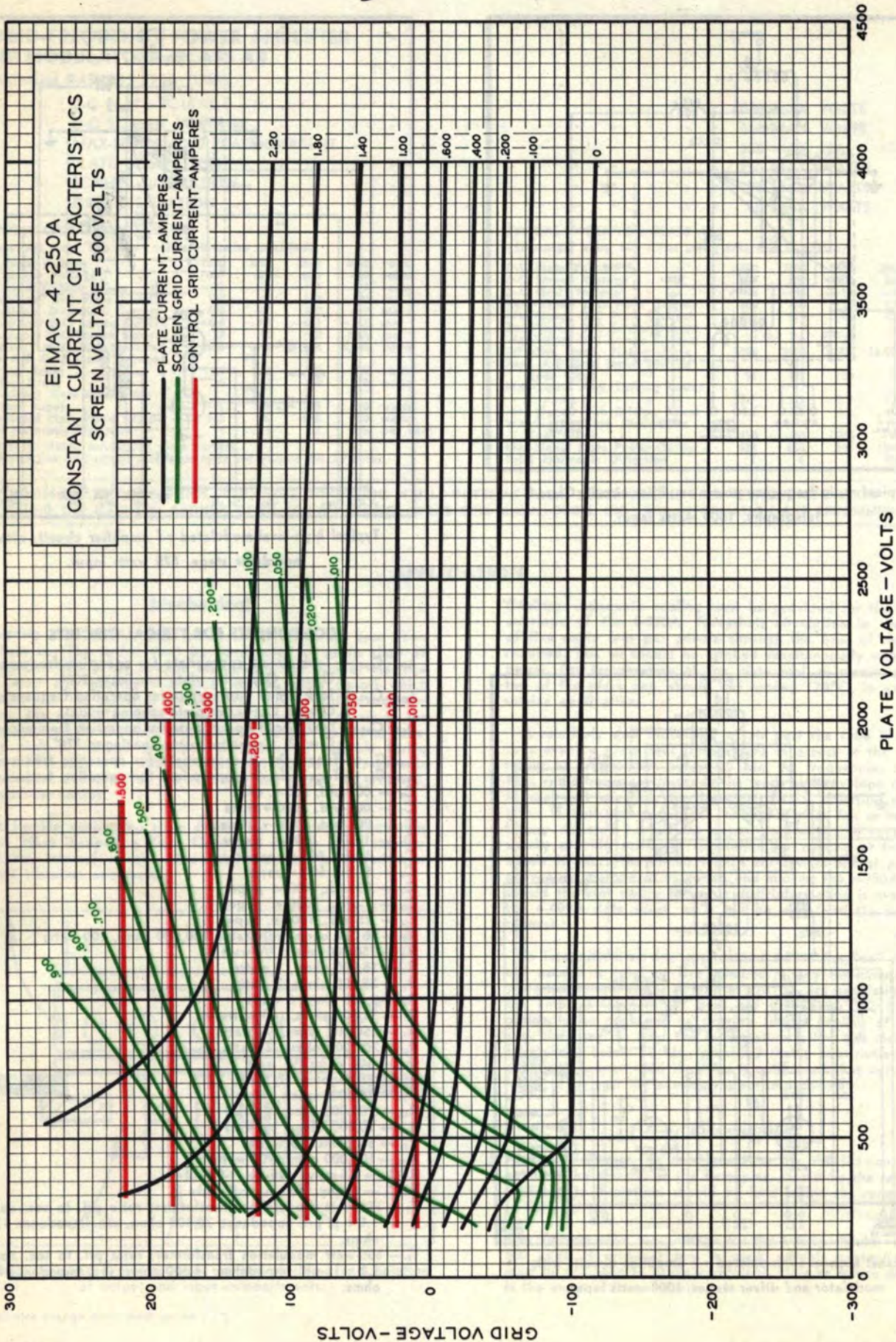

EITEL-McCULLOUGH, INC.

SAN BRUNO, CALIFORNIA

4-400A

RADIAL-BEAM
POWER TETRODE

●
MODULATOR
OSCILLATOR
AMPLIFIER

The Eimac 4-400A is a compact, ruggedly constructed power tetrode having a maximum plate dissipation rating of 400 watts. It is intended for use as an amplifier, oscillator or modulator. The low grid-plate capacitance of this tetrode coupled with its low driving-power requirement allows considerable simplification of the associated circuit and driver stage.

The 4-400A is cooled by radiation from the plate and by circulation of forced-air through the base, around the envelope, and over the plate seal. Cooling can be greatly simplified by using an Eimac 4-400A Air-System Socket and its accompanying glass chimney. This socket is designed to maintain the correct balance of cooling air between the component parts of the tube.†

GENERAL CHARACTERISTICS

ELECTRICAL

Filament: Thoriated tungsten	
Voltage	5.0 volts
Current	14.5 amperes
Grid-Screen Amplification Factor (Average)	5.1
Direct Interelectrode Capacitances (Average)	
Grid-Plate	0.12 μmfd
Input	12.5 μmfd
Output	4.7 μmfd
Transconductance ($i_b=100\text{ma.}$, $E_b=2500\text{V.}$, $E_{c2}=500\text{V.}$)	4,000 μmhos
Frequency for Maximum Ratings	110 Mc.

MECHANICAL

Base	See drawing
Basing	See drawing
Mounting Position	Vertical, base down or up
Cooling	Radiation and forced air
Recommended Heat Dissipating Plate Connector	Eimac HR-6
Recommended Socket	Eimac 4-400A Air-System Socket
Maximum Over-All Dimensions	
Length	6.38 inches
Diameter	3.56 inches
Net Weight	9 ounces
Shipping Weight	2.5 pounds
If an Air-System Socket is used, mounted on a 1/4 inch deck, the overall dimensions of the system including chimney and HR-6 Heat Dissipating Plate Connector are:	
Length	8.0 inches
Diameter	5.5 inches

Note: Typical operation data are based on conditions of adjusting to a specified plate current, maintaining fixed conditions of grid bias, screen voltage, and r-f grid voltage. It will be found that if this procedure is followed, there will be little variation in power output between tubes even though there may be some variation in grid and screen currents. Where grid bias is obtained principally by means of a grid resistor, to control plate current it is necessary to make the resistor adjustable.

RADIO FREQUENCY POWER AMPLIFIER AND OSCILLATOR

Class-C Telegraphy or FM Telephony

MAXIMUM RATINGS (Key-down conditions, per tube to 110 Mc.)

D-C PLATE VOLTAGE	4000 MAX. VOLTS
D-C SCREEN VOLTAGE	600 MAX. VOLTS
D-C PLATE CURRENT	350 MAX. MA
PLATE DISSIPATION	400 MAX. WATTS
SCREEN DISSIPATION	35 MAX. WATTS
GRID DISSIPATION	10 MAX. WATTS

TYPICAL OPERATION (Frequencies below 75 Mc., one tube)

D-C Plate Voltage	2500	3000	4000	volts
D-C Screen Voltage	500	500	500	volts
D-C Grid Voltage	-200	-220	-220	volts
D-C Plate Current	350	350	350	ma
D-C Screen Current	46	46	40	ma
D-C Grid Current	18	19	18	ma
Screen Dissipation	23	23	20	watts
Grid Dissipation	1.8	1.9	1.8	watts
Peak R-F Grid Input Voltage	300	320	320	volts
Driving Power*	5.4	6.1	5.8	watts
Plate Power Input	875	1050	1400	watts
Plate Dissipation	235	250	300	watts
Plate Power Output	640	800	1100	watts

*Driving Power increases as frequency is increased. At 75 Mc. the driving power required is approximately 12 watts.

TYPICAL OPERATION (110 Mc., two tubes)

D-C Plate Voltage	3500	4000	volts
D-C Screen Voltage	500	500	volts
D-C Grid Voltage	-170	-170	volts
D-C Plate Current	500	540	ma
D-C Screen Current	34	31	ma
D-C Grid Current	20	20	ma
Driving Power (approx.)	20	20	watts
Plate Power Output (approx.)	1300	1600	watts
Useful Power Output	1160	1440	watts

†Guarantee applies only when the 4-400A is used as specified with adequate air in the 4-400A Air-System Socket or equivalent.

(Effective 1-30-53) Copyright 1953 by Eitel-McCullough, Inc.
‡Indicates change from sheet dated 4-1-51.



PLATE MODULATED RADIO FREQUENCY AMPLIFIER

Class-C Telephony (Carrier conditions unless otherwise specified. One tube)

MAXIMUM RATINGS

D-C PLATE VOLTAGE	- - -	3200 MAX. VOLTS
D-C SCREEN VOLTAGE	- - -	600 MAX. VOLTS
D-C GRID VOLTAGE	- - -	-500 MAX. VOLTS
D-C PLATE CURRENT	- - -	275 MAX. MA
PLATE DISSIPATION	- - -	270 MAX. WATTS
SCREEN DISSIPATION	- - -	35 MAX. WATTS
GRID DISSIPATION	- - -	10 MAX. WATTS

TYPICAL OPERATION (Frequencies below 75 Mc.)

D-C Plate Voltage	- - -	2000	2500	3000	volts
D-C Screen Voltage	- - -	500	500	500	volts
D-C Grid Voltage	- - -	-220	-220	-220	volts
D-C Plate Current	- - -	275	275	275	ma
D-C Screen Current	- - -	30	28	26	ma
D-C Grid Current	- - -	12	12	12	ma
Screen Dissipation	- - -	15	14	13	watts
Grid Dissipation	- - -	1.1	1.1	1.1	watts
Peak A-F Screen Voltage (100% modulation)	- - -	350	350	350	volts
Peak R-F Grid Input Voltage	- - -	290	290	290	volts
Driving Power	- - -	3.5	3.5	3.5	watts
Plate Power Input	- - -	550	688	825	watts
Plate Dissipation	- - -	170	178	195	watts
Plate Power Output	- - -	380	510	630	watts

AUDIO FREQUENCY POWER AMPLIFIER AND MODULATOR—CLASS AB

MAXIMUM RATINGS (PER TUBE)

D-C PLATE VOLTAGE	- - -	4000 MAX. VOLTS
D-C SCREEN VOLTAGE	- - -	800 MAX. VOLTS
MAX-SIGNAL D-C PLATE CURRENT	- - -	350 MAX. MA.
PLATE DISSIPATION	- - -	400 MAX. WATTS
SCREEN DISSIPATION	- - -	35 MAX. WATTS
GRID DISSIPATION	- - -	10 MAX. WATTS

TYPICAL OPERATION CLASS AB₂

(Sinusoidal wave, two tubes unless otherwise specified)

D-C Plate Voltage	- - -	2500	3000	3500	4000	volts
D-C Screen Voltage	- - -	750	750	750	750	volts
D-C Grid Voltage (approx.)*	- - -	-130	-137	-145	-150	volts
Zero-Signal D-C Plate Current	- - -	190	160	140	120	ma
Max-Signal D-C Plate Current	- - -	635	635	610	585	ma
Zero-Signal D-C Screen Current	- - -	0	0	0	0	ma
Max-Signal D-C Screen Current	- - -	28	26	32	40	ma
Effective Load, Plate-to-Plate	- - -	6800	8900	11,500	14,500	ohms
Peak A-F Grid Input Voltage (per tube)	- - -	130	137	145	150	volts
Driving Power	- - -	0	0	0	0	watts
Max-Signal Plate Dissipation (per tube)	- - -	370	400	400	400	watts
Max-Signal Plate Power Output	- - -	850	1110	1330	1540	watts

*Adjust to give stated zero-signal plate current. The D-C resistance in series with the control grid of each tube should not exceed 250,000 ohms.

TYPICAL OPERATION CLASS AB₂

(Sinusoidal wave, two tubes unless otherwise specified)

D-C Plate Voltage	- - -	2500	3000	3500	4000	volts
D-C Screen Voltage	- - -	500	500	500	500	volts
D-C Grid Voltage (approx.)*	- - -	-75	-80	-85	-90	volts
Zero-Signal D-C Plate Current	- - -	190	160	140	120	ma
Max-Signal D-C Plate Current	- - -	700	700	700	638	ma
Zero-Signal D-C Screen Current	- - -	0	0	0	0	ma
Max-Signal D-C Screen Current	- - -	50	40	38	32	ma
Effective Load, Plate-to-Plate	- - -	7200	9100	10,800	14,000	ohms
Peak A-F Grid Input Voltage (per tube)	- - -	133	140	145	140	volts
Max-Signal Peak Driving Power	- - -	8.6	9.0	10.2	7.0	watts
Max-Signal Nominal Driving Power	- - -	4.3	4.5	5.1	3.5	watts
Max-Signal Plate Dissipation (per tube)	- - -	320	363	400	400	watts
Max-Signal Plate Power Output	- - -	1110	1375	1650	1750	watts

*Adjust for stated zero-signal plate current.

Pulse Service—For information on Pulse Service Ratings, "Application Bulletin No. 3, Pulse Service Notes", will be furnished free on request.

IF IT IS DESIRED TO OPERATE THIS TUBE UNDER CONDITIONS WIDELY DIFFERENT FROM THOSE GIVEN UNDER "TYPICAL OPERATION", POSSIBLY EXCEEDING THE MAXIMUM RATINGS GIVEN FOR CW SERVICE, WRITE EITEL-McCULLOUGH, INC., FOR INFORMATION AND RECOMMENDATIONS.

APPLICATION

MECHANICAL

Mounting—The 4-400A must be mounted vertically, base up or base down. The socket must be constructed so as to allow an unimpeded flow of air through the holes in the base of the tube and must also provide clearance for the glass tip-off which extends from the center of the base. The metal tube-base shell should be grounded by means of suitable spring fingers. The above requirements are met by the Eimac 4-400A Air-System Socket. A flexible connecting strap should be provided between the Eimac HR-6 cooler on the plate terminal and the external plate circuit. The tube must be protected from severe vibration and shock.

Cooling—Adequate forced-air cooling must be provided to maintain the base seals at a temperature below 200°C., and the plate seal at a temperature below 225°C.

When the Eimac 4-400A Air System Socket is used, a minimum air flow of 14 cubic feet per minute at a static pressure of 0.25 inches of water, as measured in the socket at sea level, is required to provide adequate cooling under all conditions of operation. Seal temperature limitations may require that cooling air be supplied to the tube even when the filament alone is on during standby periods.

In the event an Air-System Socket is not used, provision must be made to supply equivalent cooling of the base, the envelope, and the plate lead.

Tube temperatures may be measured with the aid of

"Tempilaq", a temperature-sensitive lacquer manufactured by the Tempil Corporation, 132 West 22nd Street, New York 11, N. Y.

ELECTRICAL

Filament Voltage—For maximum tube life the filament voltage, as measured directly at the filament pins, should be the rated voltage of 5.0 volts. Variations in filament voltage must be kept within the range from 4.75 to 5.25 volts.

Bias Voltage—The d-c bias voltage for the 4-400A should not exceed 500 volts. If grid leak bias is used, suitable means must be provided to prevent excessive plate or screen dissipation in the event of loss of excitation, and the grid-leak resistor should be made adjustable to facilitate maintaining the bias voltage and plate current at the desired values from tube to tube. In operation above 50 Mc., it is advisable to keep the bias voltage as low as is practicable. (See Operation)

Screen Voltage—The d-c screen voltage for the 4-400A should not exceed 600 volts in r-f applications. In audio applications a maximum d-c screen voltage of 800 volts may be used. The screen voltages shown under "Typical Operation" are representative voltages for the type of operation involved.

Plate Voltage—The plate-supply voltage for the 4-400A should not exceed 4000 volts in CW and audio applications. In plate-modulated telephony service the d-c plate-supply voltage should not exceed 3200 volts.

Indicates change from sheet dated 4-1-51.

Grid Dissipation—Grid dissipation for the 4-400A should not be allowed to exceed 10 watts. Grid dissipation may be calculated from the following expression:

$$P_g = e_{emp} I_c$$

where P_g = Grid Dissipation
 e_{emp} = Peak positive grid to cathode voltage, and
 I_c = D-c grid current

e_{emp} may be measured by means of a suitable peak voltmeter connected between filament and grid. (For suitable peak v.t.v.m. circuits see Eimac Application Bulletin Number 6, "Vacuum Tube Ratings." This bulletin is available on request.)

Screen Dissipation—The power dissipated by the screen of the 4-400A must not exceed 35 watts. Screen dissipation is likely to rise to excessive values when the plate voltage, bias voltage or plate load are removed with filament and screen voltages applied. Suitable protective means must be provided to limit screen dissipation to 35 watts in event of circuit failure.

Plate Dissipation—Under normal operating conditions, the plate dissipation of the 4-400A should not be allowed to exceed 400 watts.

In plate modulated amplifier applications, the maximum allowable carrier-condition plate dissipation is 270 watts. The plate dissipation will rise to 400 watts under 100% sinusoidal modulation.

Plate dissipation in excess of the maximum rating is permissible for short periods of time, such as during tuning procedures.

OPERATION

CLASS-C R-F AMPLIFIER

Neutralization—If reasonable precautions are taken to prevent coupling between input and output circuits, the 4-400A may usually be operated up to the 30-Mc. region without neutralization. Below 45 Mc. the conventional type of cross-neutralization may be used with push-pull circuits, or in single-ended circuits ordinary neutralization systems may be used which provide 180° out-of-phase voltage to the grid. A simple and effective method of neutralizing single-ended tetrode circuits is described in the August 1950 issue of CQ magazine in an article by Warren B. Bruene on "How to Neutralize Your Single-ended Tetrode Final".

At frequencies above 45 Mc. the feedback is principally due to screen-lead-inductance effects. Feedback is eliminated by using series capacitance in the screen leads between the screen and ground. A variable capacitor of from 25 to 50 uufd will provide sufficient capacitance to neutralize each tube in the region of 100 Mc. The two screen terminals on the socket should be strapped together by the shortest possible lead. The lead from the midpoint of this screen strap to the variable capacitor and from the variable capacitor to ground should be made with as low inductance as possible.

In general, plate, grid, filament and screen by-pass or screen neutralizing capacitors should be returned to r-f ground with low inductance leads.

In order to take full advantage of the high power-gain obtainable with the 4-400A, care should be taken to prevent feedback from the output to input circuits. A conventional method of obtaining the necessary shielding between the grid and plate circuits is to use a suitable metal chassis with the grid circuit mounted below the deck and the plate circuit mounted above the deck. Power supply leads entering the amplifier should be bypassed to ground and properly shielded to avoid feedback coupling in these leads. The output circuit and antenna feeders should be arranged so as to preclude any possibility of feedback into other circuits.

VHF Circuits—A typical linear tank circuit for use with the 4-400A in the 110 Mc. region consists of a "quarter-wave length" plate tank and a "half-wave length" grid tank circuit. Precautions must be observed in the placement of components to avoid the possibility of accidentally creating higher frequency tank circuits than desired. This could occur if a tuning capacitor were placed in a position on the line where it would create a spurious resonant circuit above the fundamental frequency. A properly neutralized amplifier at the fundamental frequency would appear regenerative at higher parasitic frequencies, and instability or oscillation would result.

Any capacitance tuning in the plate line should be kept to a small value, acting as a trimmer for the shorting-bar tuning. Such a variable capacitor should be positioned on the plate line as close as possible to the plate leads. The tuning capacitor on the "half-wave" grid line should be positioned at the extreme end of the line away from the tube.

In many cases where parasitic oscillation or regenerative harmonic amplification occurs, it is not evident until grid excitation at the fundamental frequency is applied. If the amplifier tunes in a normal manner and the efficiency appears normal for the frequency of operation, it may be assumed that the amplifier is free of parasitic oscillation and harmonic regeneration.

VHF Operation—Above 50 Mc. electron transit time factors in the tube become important, increasing in degree as the frequency is increased. When the grid swings highly negative in potential, electrons "trapped" en route by the rapidly changing r-f voltage can be deflected from their normal paths. If excessively large r-f plate voltages exist due to light plate loading, these electrons are rejected at high velocity to bombard tube parts normally outside the electron stream. This effect occurs when an amplifier goes into parasitic oscillation, as there is practically no loading in the plate circuit and the excitation is almost always extremely high. Bombardment can cause premature tube failure by a focusing of stray electrons on metal parts or the glass envelope of a tube. Such concentration of a stray electron stream will usually overheat the material at the point of focus, with the probability of gas evolution that can lead to loss of filament emission or destruction of the tube. Where glass is the overheated material, a small hole or "suck-in" can occur, opening the tube to atmosphere. Dependent upon the degree of bombardment, tube failures can occur in a matter of minutes or after a few thousand hours of life. Either way, the full life potential is not realized.

In order to minimize stray bombardment, the following rules should be followed in vhf operation of straight-through amplifiers:—

1. Use a minimum amount of bias (not over 1.5 to 2.0 times cut-off).
2. Use only enough drive to obtain satisfactory operation and good plate efficiency.
3. Use fairly heavy plate loading. Avoid operating the plate unloaded or lightly loaded at any time. Sufficient loading is indicated by low d-c screen current. Values on the order of 7% of the d-c plate current should not be exceeded. If conditions are such that the stage must be operated lightly-loaded, then the driving power should be reduced proportionately. Install undercurrent protection, especially where unloaded operation can occur due to antenna failures or transmission line icing.
4. Operate the screen grid at a reasonably high voltage, still keeping within screen dissipation ratings.
5. Due to high charging currents present in vacuum tubes at high frequencies, it is essential that all connections to the tube terminal surfaces be kept clean and make positive, firm contact.

▶ Indicates change from sheet dated 4-1-51.

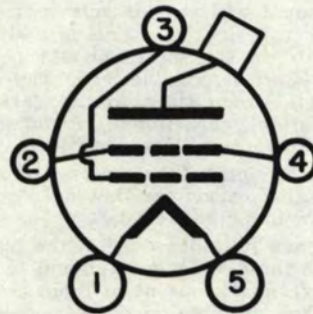
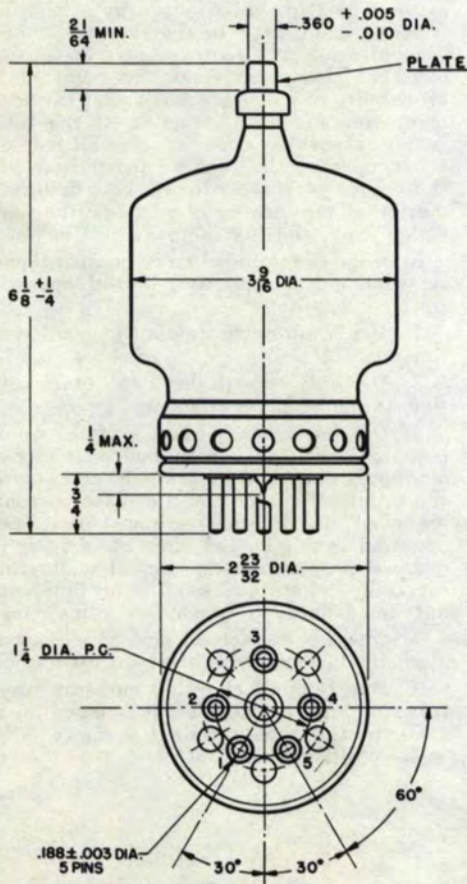
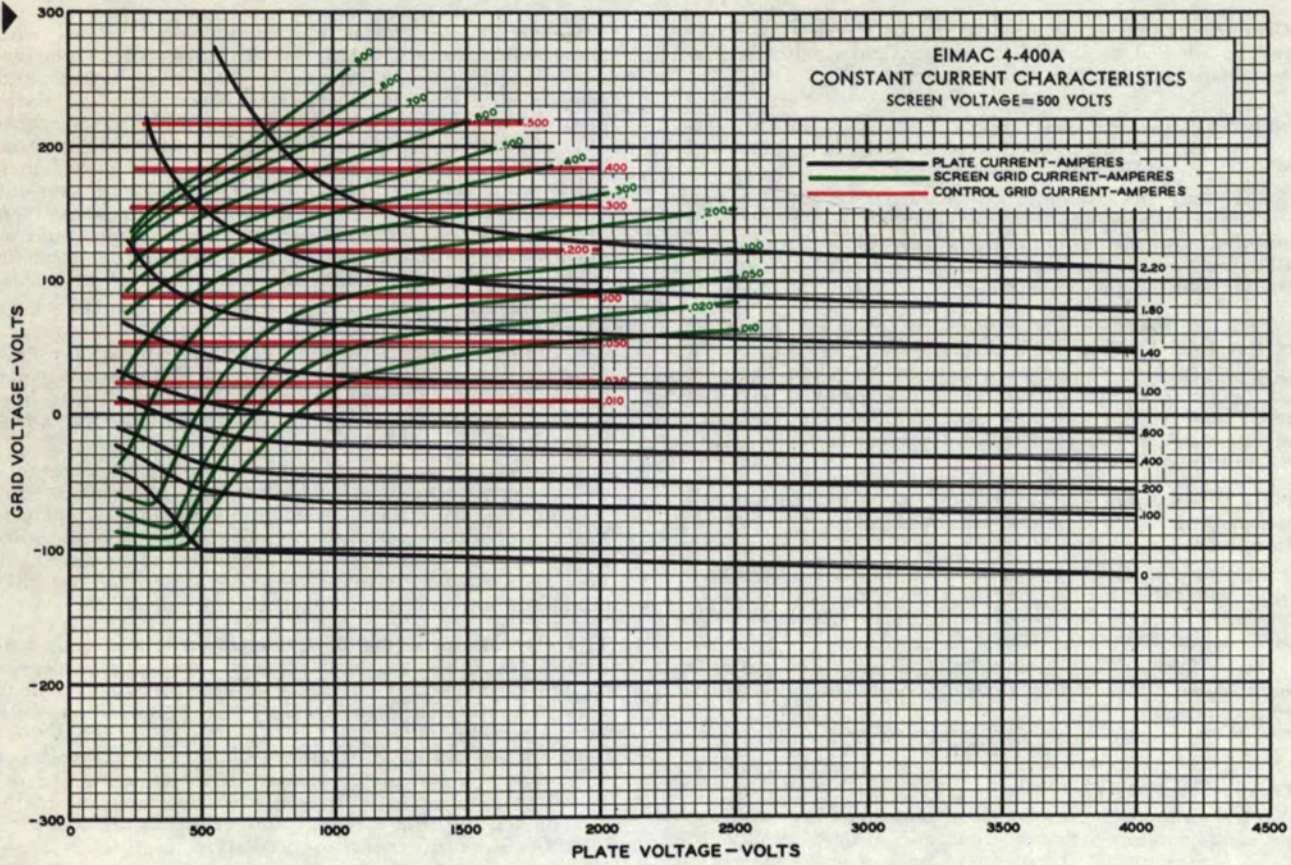

Indicates change from sheet dated 4-1-51.

Eimac
EITEL-McCULLOUGH, Inc.
 SAN BRUNO, CALIFORNIA

4-400A

**AIR-SYSTEM
 SOCKET**

► To simplify cooling of the Eimac 4-400A tetrode and assure adequate air flow to the various seals, the Eimac Air-System Socket 4-400A was developed. This system is so designed that the correct amount of cooling air is distributed to the various seals in the right proportion.

The Air-System Socket is comprised of a socket to support the 4-400A tetrode and to make the necessary base connections, clips for grounding the base shell, and a glass manifold to direct air flow to the plate terminal. The air enters the bottom of the socket through a 1/4-inch duct, cools the base terminals, flows through the base of the tube, is guided by a pyrex chimney past the glass envelope, and is directed against the plate terminal heat dissipating connector. A minimum quantity of air is thereby used effectively to cool the tube adequately under the severest requirements of the tube's rating.

A flow of 14 CFM of air is required at an inlet static pressure of 1/4" of water. The blower must be capable of supplying these requirements and also whatever added pressure drop is introduced by the connecting ducts and air filters. These air requirements are readily satisfied by a small centrifugal blower driven by a motor requiring less than 50 watts of power.

These air figures are based on sea-level operation with an ambient temperature of 25°C. and for amplifier operation at 110 Mc. where the r-f charging current into the plate-screen capacitance is most severe. Cooling the 4-400A with this socket as recommended will keep all base seals below the maximum allowable temperature limit of 200°C. and the plate seal below the allowable limit of 225°C. Determination of the proper flow of air can be made by measuring the pressure existing in the socket housing. A 1/4 inch hole, tapped with 28 threads per inch is provided to make connection to a water manometer. The static pressure at this point is 1/4 inch of water when 14 CFM is flowing. The manometer tube probe should be flush with the inside surface of the socket manifold.

The 4-400A Air-System Socket can also be used without modification for the Eimac 4-250A and 4-125A tetrodes.

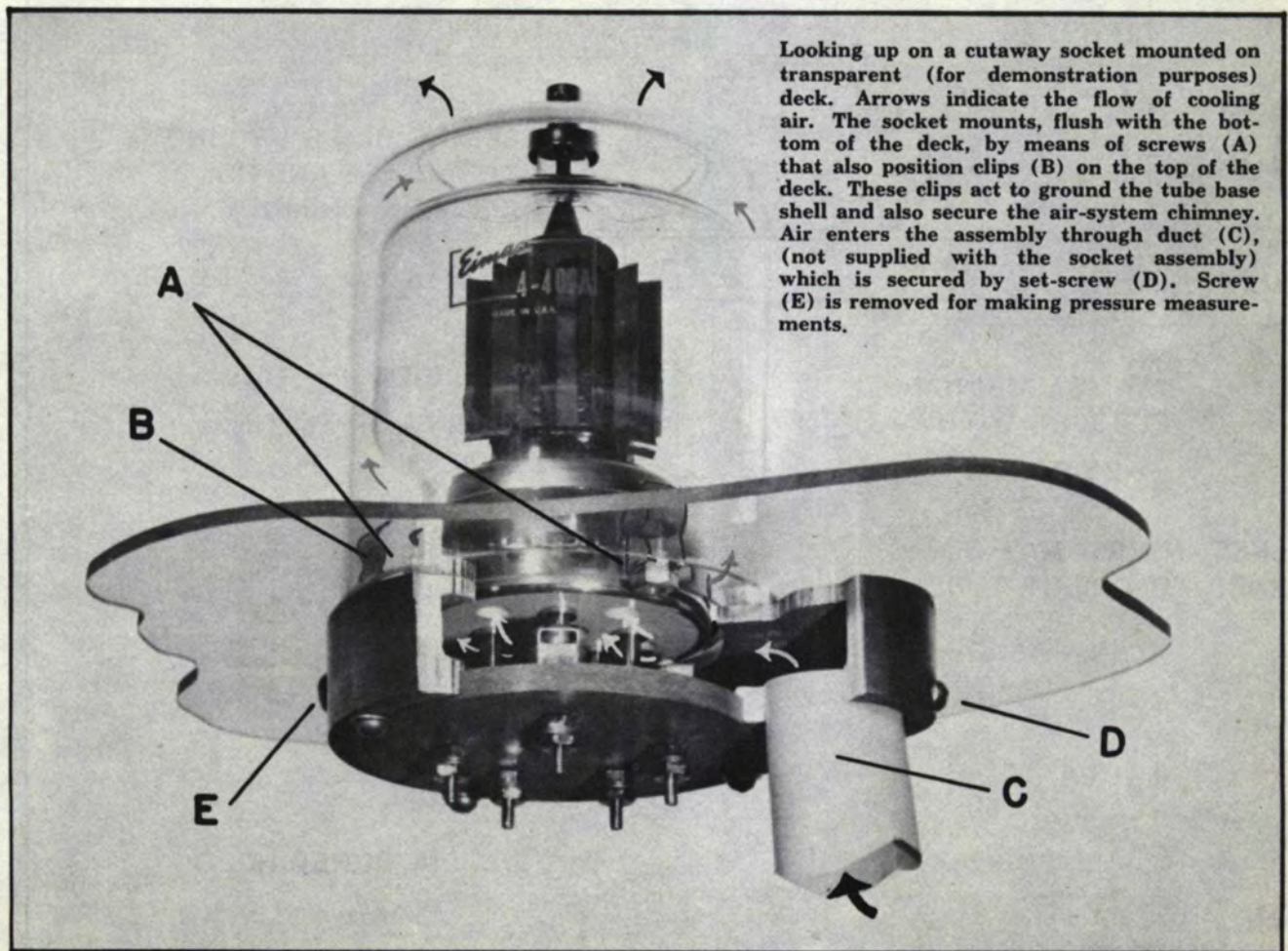

Looking up on a cutaway socket mounted on transparent (for demonstration purposes) deck. Arrows indicate the flow of cooling air. The socket mounts, flush with the bottom of the deck, by means of screws (A) that also position clips (B) on the top of the deck. These clips act to ground the tube base shell and also secure the air-system chimney. Air enters the assembly through duct (C), (not supplied with the socket assembly) which is secured by set-screw (D). Screw (E) is removed for making pressure measurements.

10-32 MACHINE
 SCREWS MOUNT
 SPRING CLIPS AND
 SOCKET ON CHASSIS

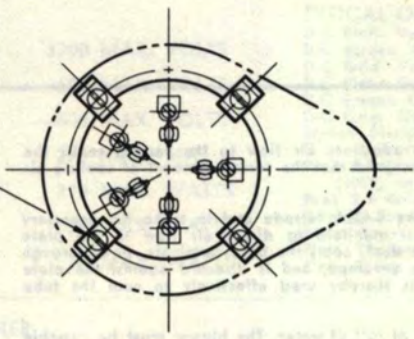

TOP VIEW

3" DIA. HOLE THRU
 CHASSIS

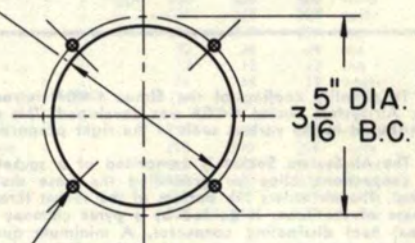

CHASSIS
 DRILLING

#9 (.196) DRILL THRU
 4 HOLES

CHASSIS
 THICKNESS

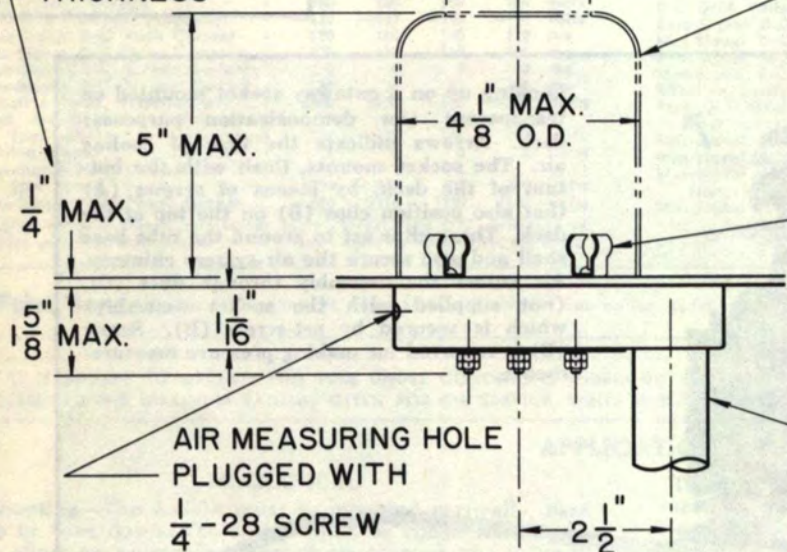

AIR
 HOLE

GLASS AIR
 FLOW CHIMNEY

SPRING CLIPS GROUND
 TUBE BASE AND HOLD
 AIR FLOW CHIMNEY

AIR MEASURING HOLE
 PLUGGED WITH
 1/4 -28 SCREW

AIR INLET 1 1/4" O.D.
 TUBING OR FITTING

SOCKET INSERT MAY BE
 TURNED TO ORIENT TUBE

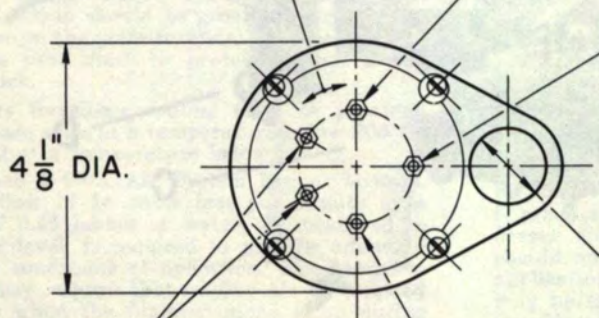

SCREEN GRID

CONTROL GRID

1.253
 1.258 DIA. BORED HOLE

FILAMENT

SCREEN GRID

4-1000A

**RADIAL-BEAM
POWER TRODE
MODULATOR
OSCILLATOR
AMPLIFIER**

EITEL-McCULLOUGH, INC.
SAN BRUNO, CALIFORNIA

The Eimac 4-1000A is a beam power tetrode with a maximum plate dissipation rating of 1000 watts. Intended for use as an amplifier, oscillator, or modulator, the 4-1000A is capable of efficient operation well into the vhf range.

In FM broadcast service on 110 Mc., two 4-1000A tetrodes will deliver a useful power output over 5000 watts.

Operating under class AB₂ modulator conditions with less than 10 watts of peak driving power, two of these tubes will deliver 3900 watts of output power.

With zero watts driving power in class AB₁, a pair of 4-1000A tetrodes will deliver 3800 watts of power output.

Cooling of the tube is accomplished by radiation from the plate and by circulation of forced-air through the base and around the envelope. Cooling can be simplified through the use of the Eimac 4-1000A Air-System Socket.

GENERAL CHARACTERISTICS

ELECTRICAL

Filament: Thoriated tungsten	
Voltage	- 7.5 volts
Current	- 21 amperes
Grid-Screen Amplification Factor (Average)	- 7
Direct Interelectrode Capacitances (Average)	
Grid-Plate (without shielding, base grounded)	- 0.24 $\mu\mu\text{fd}$
Input	- 27.2 $\mu\mu\text{fd}$
Output	- 7.6 $\mu\mu\text{fd}$
Transconductance ($i_b = 300 \text{ ma.}, E_b = 2500 \text{ v.}, E_{c2} = 500 \text{ v.}$)	- 10,000 μmhos
Highest Frequency for Maximum Ratings	- 110 Mc

MECHANICAL

Base	-	5-pin metal shell (see dwg.)
Basing	-	See drawing
Recommended Socket	-	Eimac 4-1000A Air-System Socket
Mounting position	-	Vertical, base down or up
Cooling	-	- Radiation and forced air
Recommended Heat Dissipating Connector:		
Plate	-	Eimac HR-8
Maximum Over-all Dimensions:		
Length	-	9.63 inches
Diameter	-	5.25 inches
Net Weight (tube only)	-	1.5 pounds
Shipping Weight	-	12 pounds
If an Air-System Socket is used, mounted on a 1/4" deck, the over-all dimensions of the system including chimney and HR-8 cooler are		
Length	-	11.75 inches
Diameter	-	7.5 inches

Note: Typical operation data are based on conditions of adjusting to a specified plate current, maintaining fixed conditions of grid bias, screen voltage and r-f grid voltage. It will be found that if this procedure is followed, there will be little variation in power output between tubes even though there may be some variation in grid and screen currents. Where grid bias is obtained principally by means of a grid resistor, to control plate current it is necessary to make the resistor adjustable.

RADIO FREQUENCY POWER AMPLIFIER AND OSCILLATOR

Class-C Telephony or FM Telephony

MAXIMUM RATINGS (Key-down conditions, per tube to 110 Mc.)

D-C PLATE VOLTAGE	-	6000 MAX. VOLTS
D-C SCREEN VOLTAGE	-	1000 MAX. VOLTS
D-C GRID VOLTAGE	-	-500 MAX. VOLTS
D-C PLATE CURRENT	-	700 MAX. MA
PLATE DISSIPATION	-	1000 MAX. WATTS
SCREEN DISSIPATION	-	75 MAX. WATTS
GRID DISSIPATION	-	25 MAX. WATTS

TYPICAL OPERATION (Frequencies below 110 Mc., one tube)

D-C Plate Voltage	-	3000	4000	5000	6000	volts
D-C Screen Voltage	-	500	500	500	500	volts
D-C Grid Voltage	-	-150	-150	-200	-200	volts
D-C Plate Current	-	700	700	700	700	ma
D-C Screen Current	-	146	137	147	140	ma
D-C Grid Current	-	38	39	45	42	ma
Screen Dissipation	-	73	69	73	70	watts
Grid Dissipation	-	5	6	7	6	watts
Peak R-F Grid Input Voltage (approx.)	-	290	290	355	350	volts
Driving Power (approx.)*	-	11	12	16	15	watts
Plate Power Input	-	2100	2800	3500	4200	watts
Plate Dissipation	-	670	700	690	800	watts
Plate Power Output	-	1430	2100	2810	3400	watts

*Apparent driving power requirements increase above 30 Mc. At 110 Mc. the driver should be capable of supplying 200 watts per tube to take care of feed-through, circuit losses, and radiation.

TYPICAL OPERATION (110 Mc., two tubes, push-pull)

D-C Plate Voltage	-	4000	5000	6000	volts
D-C Screen Voltage	-	450	500	500	volts
D-C Grid Voltage	-	-150	-160	-180	volts
D-C Plate Current	-	1.15	1.25	1.25	amps
D-C Screen Current	-	280	240	250	ma
D-C Grid Current	-	80	80	100	ma
Screen Dissipation (per tube)	-	63	60	63	watts
Driving Power (approx.)	-	350	400	400	watts
Plate Power Input	-	4600	6250	7500	watts
Plate Dissipation (per tube)	-	650	850	900	watts
Useful Power Output	-	3000	4200	5200	watts

These 110 Mc. typical performance figures were obtained by direct measurement in operating equipment. The output power is useful power measured in a load circuit. The driving power is that taken by the tube and a practical resonant circuit. In many cases with further refinement and improved techniques, better performance might be obtained.





4-1000A

PLATE MODULATED RADIO FREQUENCY AMPLIFIER
Class-C Telephony—Carrier Conditions

MAXIMUM RATINGS (Per tube to 110 Mc.)

D-C PLATE VOLTAGE	- - - - -	5000	MAX. VOLTS*
D-C SCREEN VOLTAGE	- - - - -	1000	MAX. VOLTS
D-C GRID VOLTAGE	- - - - -	-500	MAX. VOLTS
D-C PLATE CURRENT	- - - - -	600	MAX. MA.
PLATE DISSIPATION	- - - - -	670	MAX. WATTS
SCREEN DISSIPATION	- - - - -	75	MAX. WATTS
GRID DISSIPATION	- - - - -	25	MAX. WATTS

*5500 Max. volts below 30 Mc.

TYPICAL OPERATION (Frequencies below 110 Mc., one tube)

D-C Plate Voltage	- - -	3000	4000	5000	5500*	volts
D-C Screen Voltage	- - -	500	500	500	500	volts
D-C Grid Voltage	- - -	-200	-200	-200	-200	volts
D-C Plate Current	- - -	600	600	600	600	ma
D-C Screen Current	- - -	145	132	130	105	ma
D-C Grid Current	- - -	36	33	33	28	ma
Screen Dissipation	- - -	72	66	65	52	watts
Grid Dissipation	- - -	5	4	4	3	watts
Peak A. F. Screen Voltage (100% modulation)	- - -	250	250	250	250	volts
Peak R-F Grid Input Voltage	- - -	340	335	335	325	volts
Driving Power**	- - -	12	11	11	9	watts
Plate Power Input	- - -	1800	2400	3000	3300	watts
Plate Dissipation	- - -	410	490	560	670	watts
Plate Power Output	- - -	1390	1910	2440	2630	watts

*5500 volt operation may be used only below 30 Mc.
**Apparent driving power requirements increase above 30 Mc. At 110 Mc. the driver should be capable of supplying 200 watts per tube to take care of feed-through, circuit losses, and radiation.

AUDIO FREQUENCY POWER AMPLIFIER AND MODULATOR
Class AB

MAXIMUM RATINGS (PER TUBE)

D-C PLATE VOLTAGE	- - - - -	6000	MAX. VOLTS
D-C SCREEN VOLTAGE	- - - - -	1000	MAX. VOLTS
MAX-SIGNAL D-C PLATE CURRENT	- - - - -	700	MAX. MA
PLATE DISSIPATION	- - - - -	1000	MAX. WATTS
SCREEN DISSIPATION	- - - - -	75	MAX. WATTS

TYPICAL OPERATION

Class AB₁ (Sinusoidal wave, two tubes unless otherwise specified)

D-C Plate Voltage	- - -	4000	5000	6000	volts
D-C Screen Voltage	- - -	1000	1000	1000	volts
D-C Grid Voltage (approx.)*	- - -	-115	-125	-135	volts
Zero-Signal D-C Plate Current	- - -	300	240	200	ma
Max-Signal D-C Plate Current	- - -	1.05	1.00	.95	amp
Zero-Signal D-C Screen Current	- - -	0	0	0	ma
Max-Signal D-C Screen Current	- - -	60	60	64	ma
Effective Load, Plate-to-Plate	- - -	7000	10,000	14,000	ohms
Peak A-F Grid Input Voltage (per tube)	- - -	115	125	135	volts
Driving Power	- - -	0	0	0	watts
Max-Signal Plate Dissipation (per tube)	- - -	930	950	930	watts
Max-Signal Plate Power Output	- - -	2340	3100	3840	watts

*Adjust to give stated zero-signal plate current. The D-C resistance in series with the control grid of each tube should not exceed 250,000 ohms.

TYPICAL OPERATION

Class AB₂ (Sinusoidal wave, two tubes unless otherwise specified)

D-C Plate Voltage	- - -	4000	5000	6000	volts
D-C Screen Voltage	- - -	500	500	500	volts
D-C Grid Voltage (approx.)*	- - -	-60	-70	-75	volts
Zero-Signal D-C Plate Current	- - -	300	200	150	ma
Max-Signal D-C Plate Current	- - -	1.20	1.10	.95	amp
Zero-Signal D-C Screen Current	- - -	0	0	0	ma
Max-Signal D-C Screen Current	- - -	95	90	65	ma
Effective Load, Plate-to-Plate	- - -	7000	11,000	15,000	ohms
Peak A-F Grid Input Voltage (per tube)	- - -	140	145	130	volts
Max-Signal Peak Driving Power	- - -	11.0	11.0	9.4	watts
Max-Signal Nominal Driving Power (approx.)	- - -	5.5	5.5	4.7	watts
Max-Signal Plate Dissipation (per tube)	- - -	900	850	900	watts
Max-Signal Plate Power Output	- - -	3000	3800	3900	watts

*Adjust to give stated zero-signal plate current.

IF IT IS DESIRED TO OPERATE THIS TUBE UNDER CONDITIONS WIDELY DIFFERENT FROM THOSE GIVEN UNDER "TYPICAL OPERATION", POSSIBLY EXCEEDING THE MAXIMUM RATINGS GIVEN FOR CW SERVICE, WRITE EITEL-McCULLOUGH, INC., FOR INFORMATION AND RECOMMENDATIONS.

Pulse Service—For information on Pulse Service Ratings, "Application Bulletin No. 3, Pulse Service Notes", will be furnished free on request.

APPLICATION

MECHANICAL

Mounting—The 4-1000A must be mounted vertically base up or base down. The socket must be constructed so as to allow an unimpeded flow of air through the holes in the base of the tube. The socket must also provide clearance for the glass tip-off which extends from the center of the base. The metal tube base shell should be grounded by means of suitable spring fingers. A flexible connecting strap should be provided between the HR cooler on the plate terminal and the external plate circuit. The socket must not apply excessive lateral pressure against the base pins. The tube must be protected from severe vibration and shock.

Cooling—Adequate forced-air cooling must be provided to maintain the base seal temperatures below 150°C and the plate seal below 200°C. The problem of cooling is greatly simplified by using the Eimac 4-1000A Air-System Socket and its accompanying chimney. This system is designed to maintain the correct balance of cooling air for the various parts of the tube. The minimum quantity of air required by this system for maximum power output at 110 Mc. is 45 cfm at an inlet static pressure of approximately 1.2 inches of water.

In the event that an Air-System Socket is not used, provision must be made to circulate air through the base, around the envelope and over the plate seal. This is in addition to the normal cooling required by the base. Seal

▶ Indicates changes from sheet dated 11-15-50.

temperature limitations may require that cooling air be supplied to the tube even when filament alone is on during standby periods.

Tube temperatures may be measured with the aid of "Tempilaq", a temperature-sensitive lacquer manufactured by the Tempil Corporation, 132 West 22nd Street, New York 11, N. Y.

ELECTRICAL

Filament Voltage—For maximum tube life the filament voltage, as measured directly at the filament pins, should be the rated voltage of 7.5 volts. Unavoidable variations in filament voltage must be kept within the range from 7.13 to 7.87 volts.

Bias Voltage—The D-C bias voltage for the 4-1000A should not exceed 500 volts. If grid-leak bias is used, suitable protective means must be provided to prevent excessive plate or screen dissipation in the event of loss of excitation, and the grid-leak resistor should be made adjustable to facilitate maintaining the bias voltage and plate current at the desired values from tube to tube. In the case of operation above 50 Mc., it is advisable to keep the bias voltage as low as possible. (See "Operation".)

Screen Voltage—The D-C screen voltage for the 4-1000A should not exceed 1000 volts. The screen voltages shown under "Typical Operation" are representative voltages for the type of operation involved.

Plate Voltage—The plate-supply voltage for the 4-1000A should not exceed 6000 volts in CW and audio applications. In plate-modulated telephony service above 30 Mc., the D-C plate-supply voltage should not exceed 5000 volts; however, below 30 Mc., 5500-volt operation may be used.

Grid Dissipation—Grid dissipation for the 4-1000A should not be allowed to exceed 25 watts. Grid dissipation may be calculated from the following expression:

$$P_g = e_{\text{comp}} I_c$$

where: P_g = Grid dissipation,
 e_{comp} = Peak positive grid to cathode voltage, and
 I_c = D-c grid current.

e_{comp} may be measured by means of a suitable peak volt-meter connected between filament and grid. (For suitable peak v.t.v.m. circuits, see for instance, "Vacuum Tube Ratings", Eimac News, January 1945. This article is available in reprint form on request.)

Screen Dissipation—The power dissipated by the screen of the 4-1000A must not exceed 75 watts. Screen dissipation is likely to rise to excessive values when the plate voltage, bias voltage or plate load are removed with filament and screen voltages applied. Suitable protective means must be provided to limit screen dissipation to 75 watts in event of circuit failure.

Plate Dissipation—Under normal operating conditions, the plate dissipation of the 4-1000A should not be allowed to exceed 1000 watts.

In plate modulated amplifier applications, the maximum allowable carrier-condition plate dissipation is 670 watts. The plate dissipation will rise to 1000 watts under 100% sinusoidal modulation.

Plate dissipation in excess of the maximum rating is permissible for short periods of time, such as during tuning procedures.

OPERATION

CLASS-C R-F AMPLIFIER

Neutralization—If reasonable precautions are taken to prevent coupling between input and output circuits, the 4-1000A may be operated up to the 10 Mc. region without neutralization. In the region between 10 Mc. and 30 Mc., the conventional type of cross-neutralizing may be used with push-pull circuits. In single-ended circuits ordinary neutralization systems may be used which provide 180° out of phase voltage to the grid. A simple and effective method of neutralizing single-ended tetraode circuits is described by Warren B. Bruene in "How to Neutralize Your Single-Ended Tetraode Final", in the August, 1950, issue of CQ magazine.

At frequencies above 30 Mc. the feedback is principally due to screen-lead-inductance effects. Feedback is eliminated by using series capacitance in the screen leads between the screen and ground. A variable capacitor of from 25 to 50 uufds will provide sufficient capacitance to neutralize each tube in the region of 100 Mc. When using this method, the two screen terminals on the socket should be strapped together by the shortest possible lead. The lead from the mid-point of this screen strap to the variable capacitor and from the variable capacitor to ground should be made with as low inductance as possible.

In general, plate, grid, filament and screen bypass or screen neutralizing capacitors should be returned to r-f ground through the shortest possible leads.

In order to take full advantage of the high power gain obtainable with the 4-1000A, care should be taken to prevent feedback from the output to input circuits. A conventional method of obtaining the necessary shielding between the grid and plate circuits is to use a suitable metal chassis with the grid circuit mounted below the deck and the plate circuit mounted above the deck. Power supply leads entering the amplifier should be by-

passed to ground and properly shielded to avoid feedback coupling in these leads. The output circuit and antenna feeders should be arranged so as to preclude any possibility of feedback into other circuits.

VHF Circuits—A typical linear tank circuit for use with the 4-1000A in the 110 Mc. region consists of a "quarter wavelength" plate tank and a "half wavelength" grid tank circuit. Precautions must be observed in the placement of components to avoid the possibility of accidentally creating higher frequency tank circuits than the desired one. This could occur if a tuning capacitor were placed in a position on the line where it would create a resonant circuit at or near a harmonic frequency. A properly neutralized amplifier at the fundamental frequency would appear regenerative at higher parasitic frequencies and instability or oscillation would result.

Any capacitance tuning in the plate line should be kept to a small value, acting as a trimmer for the shorting-bar tuning. Such a variable capacitor should be positioned on the plate line as close as possible to the plate leads. The tuning capacitor on the "half wave" grid line should be positioned at the extreme end of the line away from the tube.

In many cases where parasitic oscillation or regenerative harmonic amplification occurs, it is not evident until grid excitation at the fundamental frequency is applied. If the amplifier tunes in a normal manner and the efficiency appears normal for the frequency of operation, it may be assumed that the amplifier is free of parasitic oscillation and harmonic regeneration.

VHF Operation—Above 50 Mc., electron transit time factors in the tube become important, increasing in degree as the frequency is increased. When the grid swings highly negative in potential, electrons, "trapped" enroute by the rapidly changing r-f voltage, can be deflected from their normal paths. If excessively large r-f plate voltages exist due to light plate loading, these electrons are rejected at high velocity to bombard tube parts normally outside the electron stream. This effect occurs when an amplifier goes into parasitic oscillation, as there is practically no loading in the plate circuit and the excitation is almost always extremely high. Bombardment can cause premature tube failure by a focusing of stray electrons on metal parts or the glass envelope of a tube. Such concentration of a stray electron stream will usually overheat the material at the point of focus, with the probability of gas evolution that can lead to loss of filament emission or destruction of the tube. Where glass is the overheated material, a small hole or "suck-in" can occur, opening the tube to atmosphere. Dependent upon the degree of bombardment, tube failures can occur in a matter of minutes, or after a few thousand hours of life. Either way, the full life potential is not realized.

In order to minimize stray bombardment, the following rules should be followed in vhf operation of straight through amplifiers.

1. Use a minimum amount of bias (not over 1.5 to 2.0 times cut-off).
2. Use only enough drive to obtain satisfactory operation and good plate efficiency.
3. Use fairly heavy plate loading. Low plate voltage and high plate current is better than high plate voltage and low plate current. Avoid operating the stage unloaded or lightly loaded. If conditions are such that the stage must be operated lightly-loaded, then the driving power should be reduced proportionately. Install under-current protection, especially where unloaded operation can occur due to antenna failures or transmission line icing.
4. Operate the screen grid at a reasonably high voltage, still keeping within screen dissipation ratings.

▶ Indicates changes from sheet dated 11-15-50.

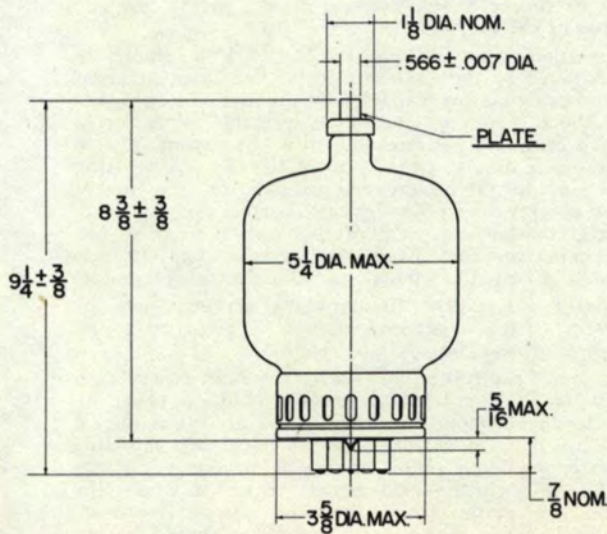
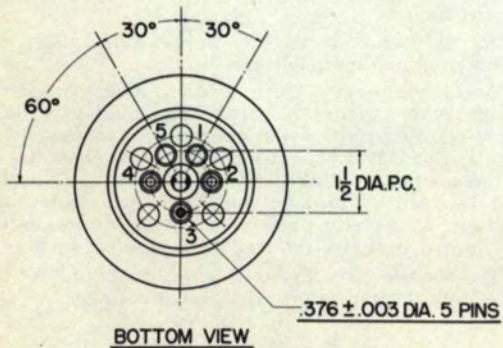
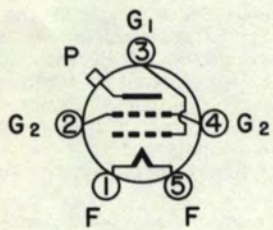
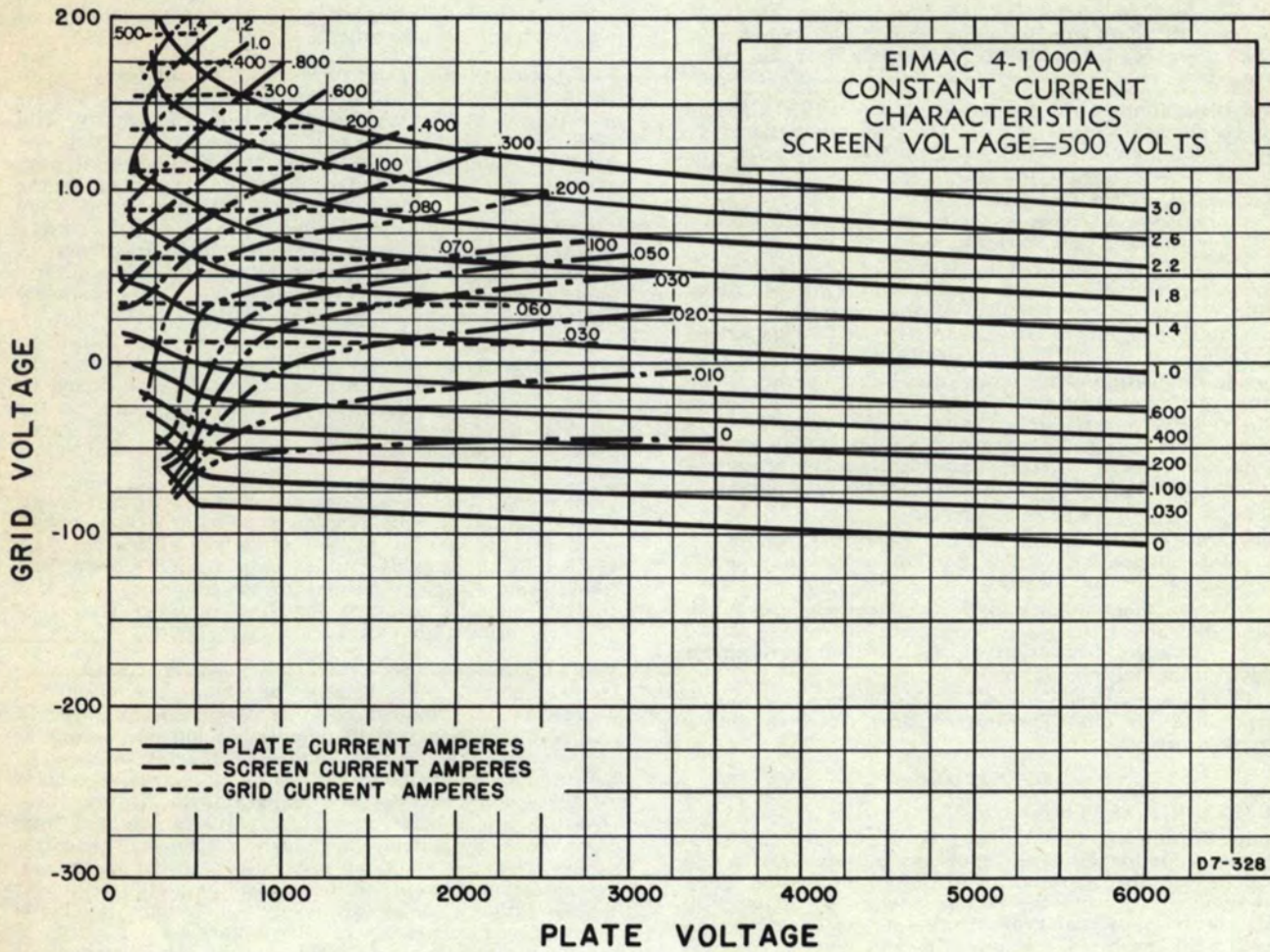

Eimac
EITEL-McCULLOUGH, INC.
 SAN BRUNO, CALIFORNIA

4-1000A

**AIR-SYSTEM
 SOCKET**

In order to simplify the cooling problem of the Eimac 4-1000A tetrode and assure adequate air-flow to the various seals, the Eimac Air-System Socket was developed. This system is so designed that the correct amount of cooling air is distributed to the various seals in the right proportion.

The Air-System Socket includes a socket to support the 4-1000A tetrode and to make the necessary base connections, and a complete air cooling system. The air enters the bottom of the socket through a 2-inch duct, cools the base terminals, flows through the base of the tube, is guided by the socket chimney past the glass envelope, and is directed against the heat dissipating connector at the plate terminal. A minimum quantity of air is thereby used effectively to cool the tube adequately under the severest requirements of the tube's ratings.

A flow of 45 CFM of air is required at an inlet static pressure of approximately 1.2" of water. The blower must be capable of supplying these requirements and also whatever added pressure drop is introduced by the connecting ducts and air filters.

These air figures are based on sea-level operation with an ambient temperature of 25°C, and for amplifier operation at 110 Mc. where the r-f charging current into the plate-screen capacitance is most severe. Cooling with this air flow will keep all base seals below the maximum allowable temperature limit of 150°C and the plate seal below the allowable limit of 200°C. Proper flow of air can be indicated by measuring the pressure existing in the cast socket. A 1/4" hole, tapped with 28 threads per inch, is provided to make connection to a water manometer. The static pressure at this point is 1.2" of water when 45 CFM is flowing. The manometer tube probe should be flush with the inside surface of the socket manifold. The hole in the probe should be made with a No. 31 drill.

Where operation is below 30 Mc., an air flow of at least 30 CFM is adequate. This corresponds to an inlet pressure at the 4-1000A socket of 0.3" of water.

In making electrical connections to the socket terminals, flexible leads should be used to preserve the freedom of motion of the connector jacks of the socket. A screw driver slot has been provided inside the jacks to hold the jacks while tightening the nuts on the underside of the socket. The first nut seats on a shoulder to prevent clamping the jack to the insulating material. The second nut should be used to secure the connector terminal lugs.

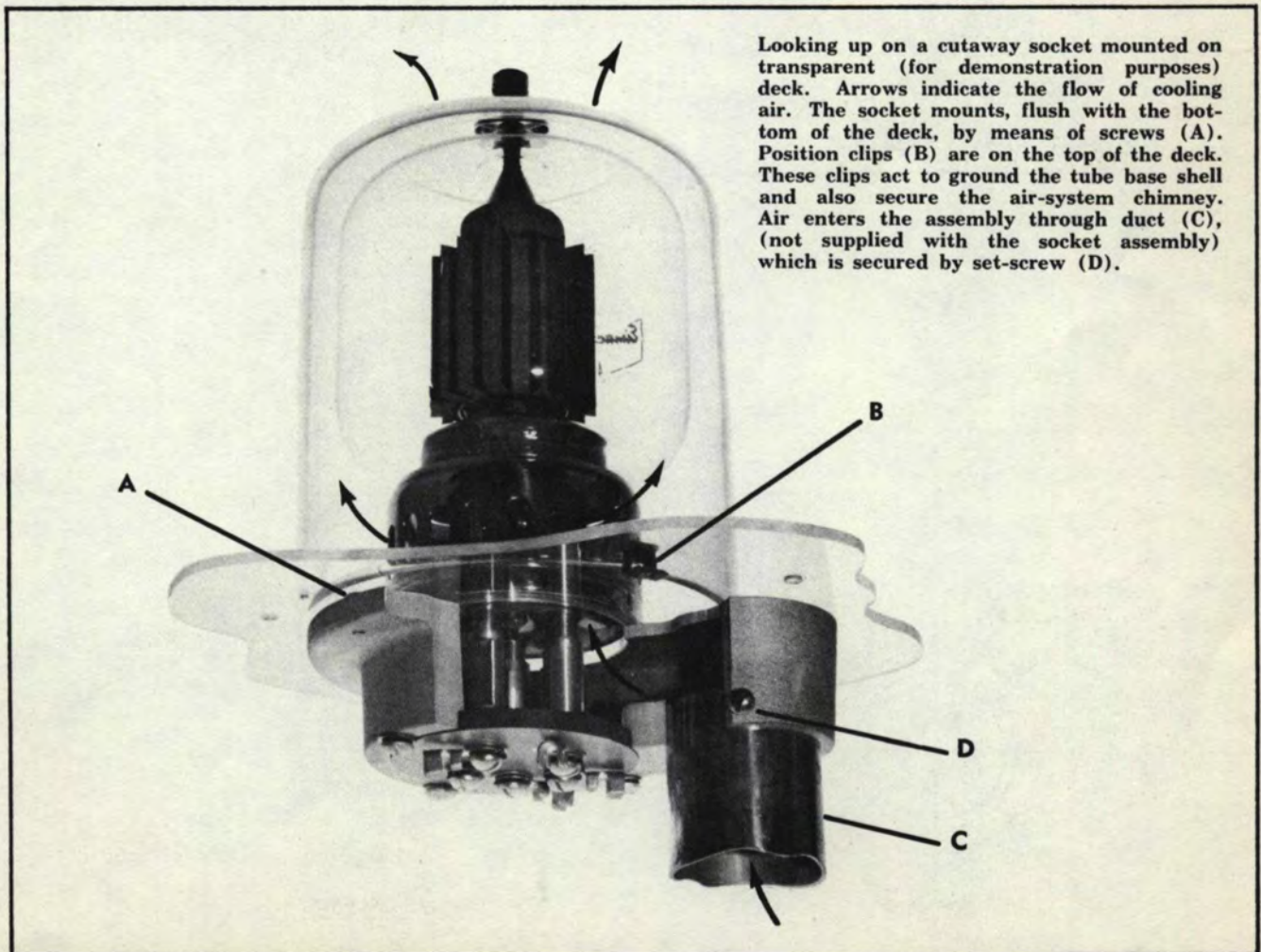
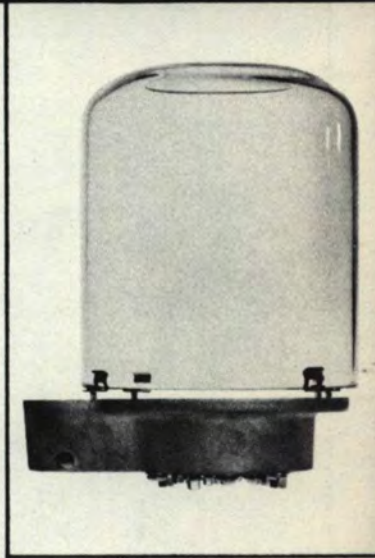

Looking up on a cutaway socket mounted on transparent (for demonstration purposes) deck. Arrows indicate the flow of cooling air. The socket mounts, flush with the bottom of the deck, by means of screws (A). Position clips (B) are on the top of the deck. These clips act to ground the tube base shell and also secure the air-system chimney. Air enters the assembly through duct (C), (not supplied with the socket assembly) which is secured by set-screw (D).

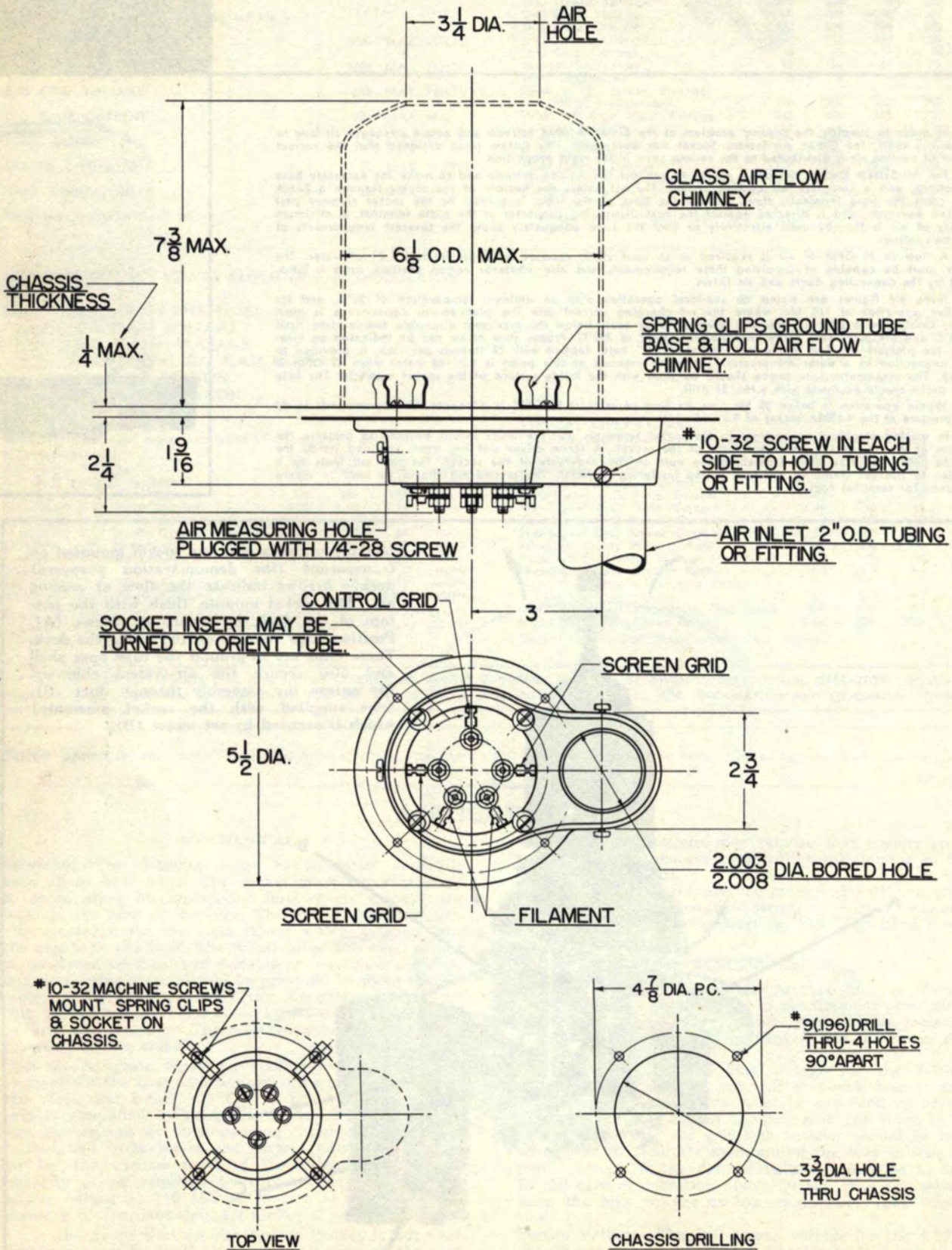

TENTATIVE DATA

Eitel-McCULLOUGH, INC.
SAN BRUNO, CALIFORNIA

4W20,000A

RADIAL-BEAM
POWER TETRODE

The Eimac 4W20000A is a high-power, water-cooled transmitting tetrode having a maximum plate dissipation rating of 20 kilowatts. This tube will operate efficiently as a power-amplifier at frequencies up to 250 Mc. A single 4W20000A operating as a television visual r-f amplifier will deliver a synchronizing power output of 20 kilowatts at 216 Mc., with a 5-Mc. bandwidth.

The coaxial terminal arrangement of the tube is ideally suited for use in cavity circuits. The cathode is a unipotential thoriated tungsten cylinder of rugged construction, heated by electron bombardment.

GENERAL CHARACTERISTICS

ELECTRICAL

Cathode: Unipotential, thoriated tungsten. Heated by electron bombardment.	
D-C Voltage (Approx.)	1600 volts
D-C Current (Approx.)	1.9 amperes
Filament: Thoriated Tungsten, Helical	
Voltage	10 volts
Current	30 amperes
Maximum allowable starting current	50 amperes
Direct Interelectrode Capacitances (Average)	
Grid-Plate	0.5 μmfd
Input	125 μmfd
Output	23 μmfd
Screen-Grid Amplification Factor (Average)	5.5
Transconductance ($I_b=6.6 \text{ A.}, E_b=3.0 \text{ kV.}, E_{c2}=1200 \text{ V.}$)	75,000 μmhos

MECHANICAL

Base	Special, Concentric
Mounting Position	Vertical, base down or up
Cooling	Water and Forced Air
▶ Maximum Overall Dimensions	
Length	15.2 inches
Diameter	5.0 inches
Net Weight	7.6 pounds
Shipping Weight	40 pounds



RADIO FREQUENCY POWER AMPLIFIER MAXIMUM RATINGS (per tube)

D-C PLATE VOLTAGE	8 MAX. KV
D-C PLATE CURRENT	15 MAX. AMP
PLATE DISSIPATION	20 MAX. KW
SCREEN DISSIPATION	200 MAX. WATTS
GRID DISSIPATION	60 MAX. WATTS

TYPICAL OPERATION

Class-C Telephony or FM Telephony (Per tube—220 Mc.)

D-C Plate Voltage	5000	6000	7000	volts
D-C Screen Voltage	1200	1200	1200	volts
D-C Grid Voltage	-350	-370	-400	volts
D-C Plate Current	3.6	3.6	3.4	amps
D-C Screen Current (approx.)*	167	167	167	ma
D-C Grid Current (approx.)	50	50	50	ma
Peak R-F Input Voltage	455	475	505	volts
Driving Power (approx.)*	750	780	830	watts
Screen Dissipation	200	200	200	watts
Plate Power Input	18	21.6	23.8	kw
Plate Dissipation	7.0	8.6	8.0	kw
Useful Power Output	9.2	11.5	13.0	kw

*The performance figures listed above are obtained by calculation from the characteristic tube curves and confirmed by direct tests. The driving power and output power allow for losses associated with practical resonant circuits.

TYPICAL OPERATION

Class-B Linear Amplifier—Television Visual Service
(Per tube, 5-Mc. Bandwidth, 216 Mc.)

Peak Synchronizing Level

Load Impedance	400	ohms
Effective Length of Plate Line	1/4	wave
D-C Plate Voltage	5500	volts
D-C Screen Voltage	1200	volts
D-C Control Grid Voltage	-240	volts
D-C Plate Current	7.1	amps
D-C Screen Current (approx.)	500	ma
D-C Control Grid Current (approx.)	140	ma
Peak R-F Grid Input Voltage	430	volts
Driving Power (approx.)	1500	watts
Plate Power Input	39.1	kw
Plate Dissipation	16.5	kw
Useful Plate Power Output	20.1	kw

Black Level

D-C Plate Current	5.3	amps
D-C Control Grid Current (approx.)	50	ma
Peak R-F Grid Input Voltage	330	volts
Driving Power (approx.)	875	watts
Plate Power Input	29.2	kw
Plate Dissipation	18.0	kw
Useful Power Output	11.2	kw

These 216 Mc. typical performance figures were obtained by direct measurement in test equipment. The output power is useful power measured in a load circuit. The driving power is that taken by the tube and a practical resonant grid circuit. These figures are subject to variation and in many cases, with further refinement and improved techniques, better performance might be obtained.

Note: Typical operation data are based on conditions of adjusting to a specified plate current, maintaining fixed conditions of grid bias, screen voltage, suppressor voltage and r-f grid voltage. It will be found that if this procedure is followed, there will be little variation in power output between tubes even though there may be some variation in grid, screen and suppressor currents. Where grid bias is obtained principally by means of a grid resistor, to control plate current it is necessary to make the resistor adjustable.

APPLICATION

Mounting—The 4W20,000A must be mounted vertically. Base-down or base-up mounting is optional.

The co-axial contact surfaces provided for connection to the filament, cathode, grid, screen, and anode are of successively larger diameters to facilitate removal and replacement of tubes.

Cavity circuits may be designed around the dimensions shown in the outline drawing. At very high frequencies the points of contact between the tube and the external circuit will be required to carry high values of charging current. It is, therefore, essential that the contactors make firm and uniform contact between the terminal surfaces of the tube and the external circuit. Particular care should be taken that the contactors are not inadvertently forced out of shape, and that all contact surfaces are maintained free from dust or other foreign matter which would prevent uniform electrical connection. At VHF, poor contact by one finger of a multi-finger collet can result in local overheating which may damage the tube seals.

Although contact fingers or slotted collets are often made an integral part of cavity circuits, there is some advantage to reversing the plan by providing contact-finger assemblies which are designed to be clamped firmly to the terminal surfaces of the tube itself and to make sliding contact with the cavity as the tube is inserted. This arrangement facilitates replacement of worn or damaged contactors and tends to remove incidental local heating from the vicinity of the tube seals. Tubes held in reserve for emergency replacement may be fitted with contact-finger assemblies and water-line extensions to minimize lost time in making changes.

Cathode Heating Power—The cathode of the 4W20,000A is a unipotential, thoriated tungsten cylinder, heated by electron bombardment of its inner surface. Bombardment is obtained by using the cylindrical cathode as the anode of a diode. A helical filament is mounted on the axis of the cathode cylinder to supply the bombarding electrons. A d-c potential of approximately 1600 volts is applied between the filament and the cathode cylinder, and the recommended cathode heating power of 3000 watts is obtained with approximately 1.9 amperes.

The inner filament is designed to operate under space-charge limited conditions so that the cathode temperature may be varied by changing

the voltage applied between the inner filament and the cathode cylinder.

For maximum tube life the filament voltage, as measured directly at the filament terminals, and the cathode power should be held at their rated values. Variations in filament voltage should be held within the range of 9.5 to 10.5 volts, cathode power within the range of 2700 to 3300 watts.

Caution: It must be kept in mind that the filament is at a potential of 1600 volts d-c with respect to ground. The filament transformer and voltmeter must be adequately insulated for this voltage.

Anode Cooling—The water-cooled anode requires 6 gallons per minute of cooling water for the rated 20 kilowatts of plate dissipation. This corresponds to a pressure drop of 1 pound per square inch across the water jacket. The inlet water pressure must not exceed a maximum of 25 pounds per square inch.

The outlet water temperature must not exceed a maximum of 70°C under any conditions.

Seal Cooling—The grid and screen tube contact surfaces and adjacent glass and ceramic must be cooled by high-velocity air which may be accomplished by means of ring manifolds. The quantity, velocity and direction of air must be adjusted to limit the maximum seal temperatures to 150°C.

The cathode and filament-stem also require forced-air cooling. A minimum of 30 cubic feet per minute must flow into the space enclosed by the outer filament spring collet connection. Part of this air flows through the three air holes provided in the center of the base of the tube. This air cools the filament stem and vents through the nine holes in the base inside the cathode terminal.

The filament spring collet fingers should be adequately spaced to allow approximately three-quarters of the air to flow through the collet. A cylindrical duct of non-metallic material, approximately 2½ inches in diameter, should be placed around the cathode connecting collet to guide the air along the cathode contacting surface and onto the cathode-to-glass seal. The temperature of the seals should not exceed 150°C.

Tube temperatures may be measured with the aid of "Tempilaq", a temperature-sensitive lacquer manufactured by the Tempil Corporation, 132 West 22nd St., New York 11, N. Y.

Air and water flow must be started before filament and cathode power are applied and maintained for at least two minutes after the filament and cathode power have been removed.

IF IT IS DESIRED TO OPERATE THIS TUBE UNDER CONDITIONS WIDELY DIFFERENT FROM THOSE GIVEN UNDER "TYPICAL OPERATION", POSSIBLY EXCEEDING THE MAXIMUM RATINGS GIVEN FOR CW SERVICE, WRITE EITEL-McCULLOUGH, INC., FOR INFORMATION AND RECOMMENDATIONS.

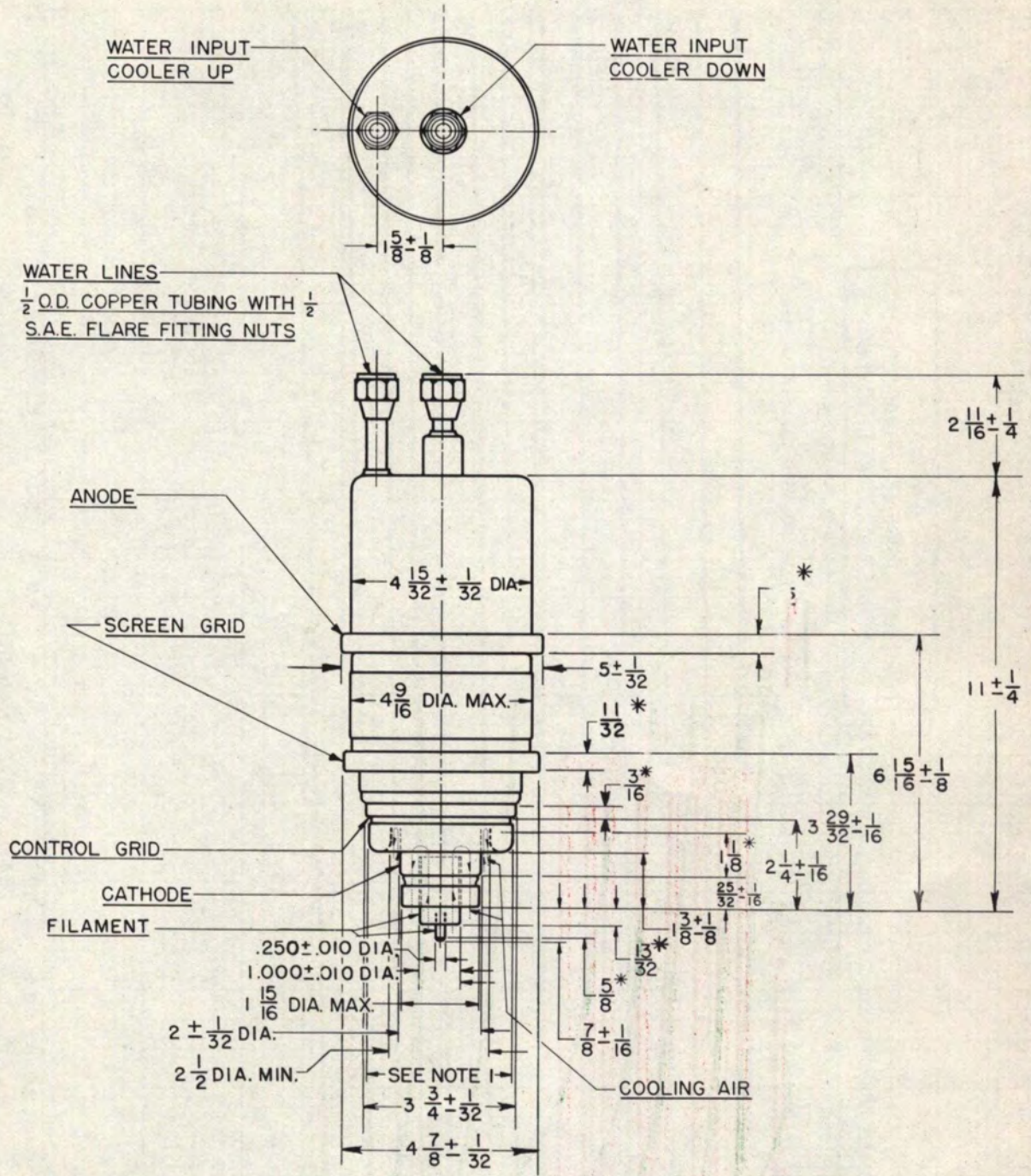

ALL DIMENSIONS
 IN INCHES
 4W20,000A



BOTTOM VIEW

NOTE I. GLASS DIAMETER LESS THAN MINIMUM DIA. OF CONTROL GRID CONTACT SURFACE.

* CONTACT AREA

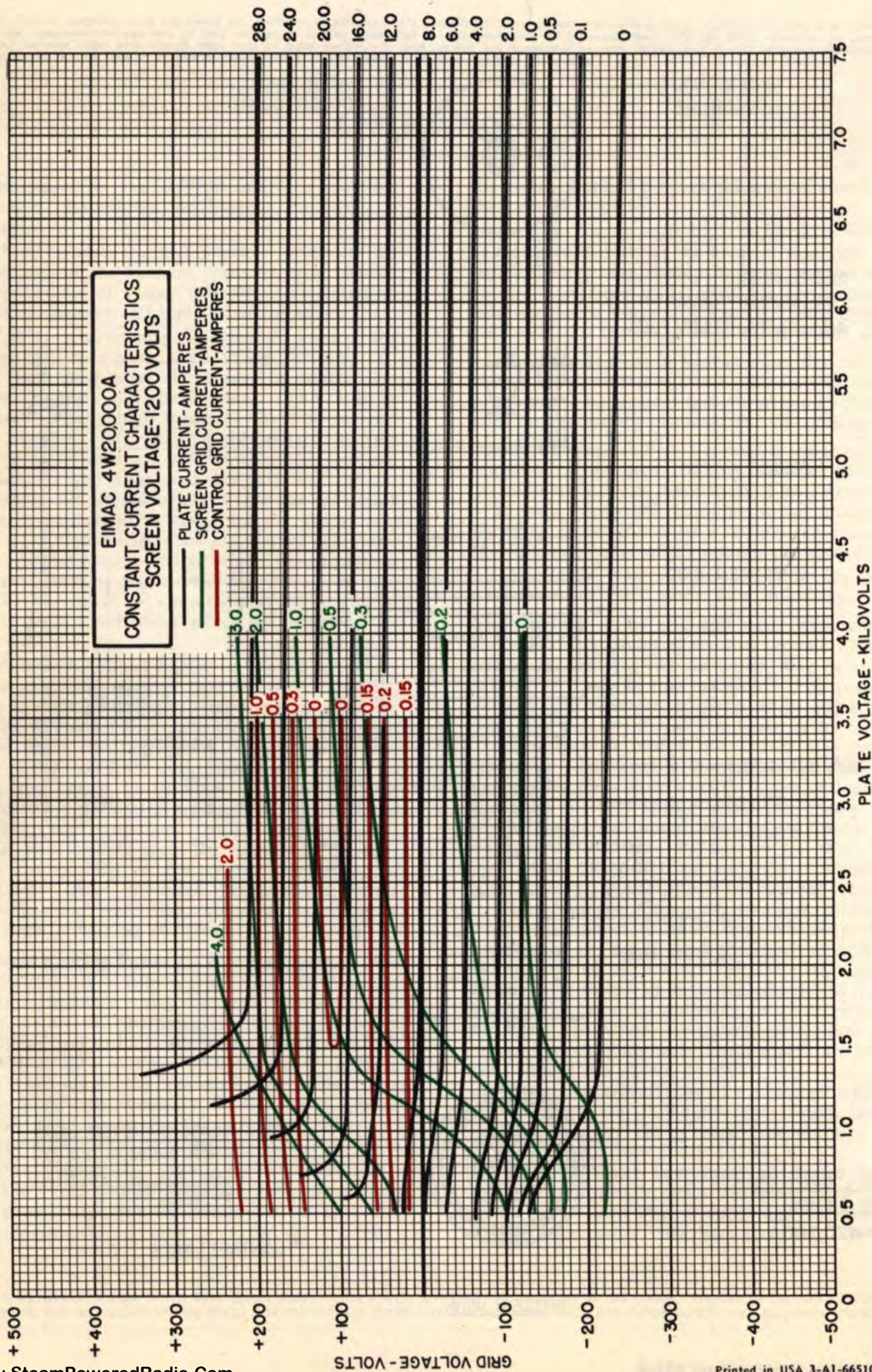

Eitel-McCullough, Inc.

SAN BRUNO, CALIFORNIA

4X150A RADIAL-BEAM POWER TETRODE

These Data apply to type 4X150D which is identical to 4X150A except for the heater rating of 26.5 volts 0.57 ampere.

The Eimac 4X150A is a compact power tetrode intended for use as an amplifier, oscillator or frequency multiplier over a wide range of frequencies extending into the UHF region. It is cooled by forced air.

A single 4X150A operating in a coaxial-cavity amplifier circuit will deliver up to 140 watts of useful power output at 500 megacycles.

The maximum rated plate voltage for the 4X150A is 1250 volts, and the tube is capable of good performance with plate voltages as low as 400 volts. Its high ratio of transconductance to capacitance and its 150-watt plate dissipation rating make the 4X150A useful for wide-band amplifier applications.

The use of the Eimac 4X150A Air-System Socket, or a socket providing equivalent air-cooling facilities, is required.

GENERAL CHARACTERISTICS

ELECTRICAL

Cathode: Oxide Coated, Unipotential			
Minimum Heating Time	- - - - -	30	seconds
Cathode-to-Heater Voltage	- - - - -	150	max. volts
Heater: Voltage	- - - - -	6.0	volts
Current	- - - - -	2.6	amperes
Grid-Screen Amplification Factor (Average)	- - - - -	-	5
Direct Interelectrode Capacitances (Average)			
Grid-Plate	- - - - -	0.03	$\mu\mu\text{f}$
Input	- - - - -	15.5	$\mu\mu\text{f}$
Output	- - - - -	4.5	$\mu\mu\text{f}$
Transconductance ($E_b = 500\text{v.}$, $E_{c2} = 250\text{v.}$, $I_b = 200\text{ ma}$)	- - - - -	-	12,000 μmhos
Frequency for Maximum Ratings	- - - - -	-	500 Mc

MECHANICAL

Base	- - - - -	-	9-pin, special
Recommended Socket	- - - - -	-	Eimac 4X150A Air-System Socket
Base Connections	- - - - -	-	See outline drawing
Mounting	- - - - -	-	Any position
Cooling	- - - - -	-	Forced air
Maximum Overall Dimensions:			
Length	- - - - -	-	2.47 inches
Diameter	- - - - -	-	1.65 inches
Seated Height	- - - - -	-	1.91 inches
Net Weight	- - - - -	-	5.2 ounces
Shipping Weight	- - - - -	-	1.6 pounds

Note: Typical operation data are based on conditions of adjusting the r-f grid drive to a specified plate current, maintaining fixed conditions of grid bias and screen voltage. It will be found that if this procedure is followed, there will be little variation in power output between tubes even though there may be some variation in grid and screen currents. Where grid bias is obtained principally by means of a grid resistor, to control plate current it is necessary to make the resistor adjustable.

RADIO-FREQUENCY POWER AMPLIFIER OR OSCILLATOR

Class-C Telegraphy or FM Telephony
(Key-down conditions, per tube)

MAXIMUM RATINGS

D-C PLATE VOLTAGE	-	1250 MAX. VOLTS
D-C SCREEN VOLTAGE	-	300 MAX. VOLTS
D-C GRID VOLTAGE	-	-250 MAX. VOLTS
D-C PLATE CURRENT	-	250 MAX. MA
PLATE DISSIPATION	-	150 MAX. WATTS
SCREEN DISSIPATION	-	12 MAX. WATTS
GRID DISSIPATION	-	2 MAX. WATTS

TYPICAL OPERATION (Frequencies up to 165 Mc., per tube)				
D-C Plate Voltage	- - - - -	600	750	1000
D-C Screen Voltage	- - - - -	250	250	250
D-C Grid Voltage	- - - - -	-75	-80	-80
D-C Plate Current	- - - - -	200	200	200
D-C Screen Current	- - - - -	37	37	30
D-C Grid Current	- - - - -	10	10	10
Peak R-F Grid Voltage (approx.)	- - - - -	90	95	95
Driving Power (approx.)	- - - - -	1	1	1
Plate Power Input	- - - - -	120	150	200
Plate Power Output	- - - - -	85	110	150

The performance figures for frequencies up to 165 Mc. are obtained by calculation from the tube characteristic curves and confirmed by direct tests. The driving power includes only power taken by the tube grid and the bias circuit. The driving power and output power do not allow for losses in the associated resonant circuits.

TYPICAL OPERATION (Single tube, 500-Mc) coaxial cavity)				
D-C Plate Voltage	- - - - -	600	800	1000
D-C Screen Voltage	- - - - -	250	250	250
D-C Grid Voltage	- - - - -	-110	-110	-115
D-C Plate Current	- - - - -	170	200	200
D-C Screen Current	- - - - -	6	7	7
D-C Grid Current	- - - - -	6	10	10
Driver Output Power (approx.)	- - - - -	15	20	25
Power Input	- - - - -	102	160	200
Useful Power Output	- - - - -	50	95	120

These typical performance figures were obtained by direct measurement in operating equipment. The output power is useful power measured in a load circuit. The driving power is the total power taken by the tube and a practical resonant circuit. In many cases with further refinement and improved techniques better performance might be obtained.

Supersedes Sheet Dated 2-15-52

(Effective 8-15-52) Copyright 1952 by Eitel-McCullough, Inc.



PLATE-MODULATED RADIO-FREQUENCY AMPLIFIER

Class-C Telephony (Carrier conditions, per tube)

MAXIMUM RATINGS

D-C PLATE VOLTAGE	-	1000	MAX. VOLTS
D-C SCREEN VOLTAGE	-	300	MAX. VOLTS
D-C GRID VOLTAGE	-	-250	MAX. VOLTS
D-C PLATE CURRENT	-	200	MAX. MA
PLATE DISSIPATION	-	100	MAX. WATTS
SCREEN DISSIPATION	-	12	MAX. WATTS
GRID DISSIPATION	-	2	MAX. WATTS

TYPICAL OPERATION (Frequencies up to 165 Mc.)

D-C Plate Voltage	-	400	600	800	1000	volts
D-C Screen Voltage	-	250	250	250	250	volts
D-C Grid Voltage	-	-90	-95	-100	-105	volts
D-C Plate Current	-	200	200	200	200	ma
D-C Screen Current	-	40	35	25	20	ma
D-C Grid Current	-	7	8	10	15	ma
Peak A-F Screen Voltage at crest of 100% Modulation	-	140	150	160	170	volts
Peak R-F Grid Input Voltage (approx.)	-	110	120	120	125	volts
Driving Power (approx.)	-	1	1	1.5	2	watts
Plate Dissipation	-	25	40	60	60	watts
Plate Power Input	-	80	120	160	200	watts
Plate Power Output	-	55	80	100	140	watts

RADIO-FREQUENCY POWER AMPLIFIER

Class-B Linear, Television Visual Service (per tube)

MAXIMUM RATINGS

D-C PLATE VOLTAGE	-	1250	MAX. VOLTS
D-C SCREEN VOLTAGE	-	400	MAX. VOLTS
D-C GRID VOLTAGE	-	-250	MAX. VOLTS
D-C PLATE CURRENT (AVERAGE)	-	250	MAX. MA
PLATE DISSIPATION	-	150	MAX. WATTS
SCREEN DISSIPATION	-	12	MAX. WATTS
GRID DISSIPATION	-	2	MAX. WATTS

TYPICAL OPERATION (Frequencies up to 216 Mc., 5-Mc. bandwidth)

D-C Plate Voltage	-	750	1000	1250	volts
D-C Screen Voltage	-	300	300	300	volts
D-C Grid Voltage	-	-60	-65	-70	volts
During Sync-Pulse Peak:					
D-C Plate Current	-	335	330	305	ma
D-C Screen Current	-	50	45	45	ma
D-C Grid Current	-	15	20	25	ma
Peak R-F Grid Voltage	-	85	95	100	volts
R-F Driver Power (approx.)	-	7	8	9	watts
Useful Power Output	-	135	200	250	watts
Black Level:					
D-C Plate Current	-	245	240	230	ma
D-C Screen Current	-	20	15	10	ma
D-C Grid Current	-	4	4	4	ma
Peak R-F Grid Voltage (approx.)	-	65	70	75	volts
R-F Driver Power (approx.)	-	4.25	4.7	5.5	watts
Plate Power Input	-	185	240	290	watts
Useful Power Output	-	75	110	140	watts

CLASS-AB OR -B POWER AMPLIFIER OR MODULATOR

MAXIMUM RATINGS (Per tube)

D-C PLATE VOLTAGE	-	1250	MAX. VOLTS
D-C SCREEN VOLTAGE	-	400	MAX. VOLTS
D-C PLATE CURRENT	-	250	MAX. MA
PLATE DISSIPATION	-	150	MAX. WATTS
SCREEN DISSIPATION	-	12	MAX. WATTS
GRID DISSIPATION	-	2	MAX. WATTS

TYPICAL OPERATION

Class AB ₁ (Sinusoidal wave, two tubes unless otherwise specified)						
D-C Plate Voltage	-	600	800	1000	1250	volts
D-C Screen Voltage	-	300	300	300	300	volts
D-C Grid Voltage (approx.)*	-	-44	-47	-47	-48	volts
Zero-Signal D-C Plate Current	-	160	120	120	115	ma
Max-Signal D-C Plate Current	-	380	380	380	390	ma
Zero-Signal D-C Screen Current	-	0	0	0	0	ma
Max-Signal D-C Screen Current	-	65	65	60	40	ma
Effective Load, Plate-to-Plate	-	3550	4625	5850	7200	ohms
Peak A-F Grid Input Voltage (per tube)	-	44	47	47	48	volts
Driving Power	-	0	0	0	0	watts
Max-Signal Plate Dissipation (per tube)	-	45	55	70	90	watts
Max-Signal Plate Power Output	-	140	195	240	310	watts

*Adjust grid voltage to obtain specified zero-signal plate current. Maximum permissible grid circuit series resistance 100,000 ohms per tube.

TYPICAL OPERATION

Class AB ₂ (Sinusoidal wave, two tubes unless otherwise specified)						
D-C Plate Voltage	-	600	800	1000	1250	volts
D-C Screen Voltage	-	300	300	300	300	volts
D-C Grid Voltage**	-	-41	-43	-43	-44	volts
Zero-Signal D-C Plate Current	-	185	160	165	180	ma
Max-Signal D-C Plate Current	-	485	490	495	475	ma
Zero-Signal D-C Screen Current	-	0	0	0	0	ma
Max-Signal D-C Screen Current	-	85	75	70	65	ma
Effective Load, Plate-to-Plate	-	2600	3500	4600	5600	ohms
Peak A-F Grid Input Voltage (per tube)	-	47	48	49	50	volts
Max-Signal Peak Driving Power	-	0.15	0.15	0.15	0.15	watts
Max-Signal Nominal Driving Power (approx.)	-	75	75	75	75	mw
Max-Signal Plate Dissipation (per tube)	-	60	75	90	85	watts
Max-Signal Plate Power Output	-	170	240	315	425	watts

**Adjust grid voltage to obtain specified zero-signal plate current.

APPLICATION

MECHANICAL

Mounting—The 4X150A may be mounted in any position. Use of the Eimac 4X150A Air-System Socket, or its equivalent, is required.

The tube will fit a standard "loktal" socket, but the use of such a socket prevents adequate air-cooling of the base of the tube. Use of the "loktal" socket is not recommended.

Connections to the terminals of all the electrodes except the plate are provided by the Air-System Socket. The anode-cooler assembly provides a terminal surface for the plate connection. For high-frequency applications a metal band or a spring-finger collet should be used to make good electrical contact with the cylindrical outer surface of the anode cooler. Points of electrical contact should be kept clean and free of oxidation to minimize r-f losses.

Cooling—The 4X150A requires sufficient forced-air cooling to keep the cooler core and the metal parts of the metal-to-glass seals from exceeding a maximum temperature of 150°C. The air flow must be started when power is applied to the heater, and must continue without interruption until all electrode voltages have been removed from the tube.

The Eimac Air-System Socket directs the air over the surfaces of the tube base, and through the anode cooler to provide effective cooling with a minimum air flow. Seven and one-half cubic feet of cooling air per minute must flow through the Air-System Socket and the anode cooler for adequate cooling. This corresponds to a total pressure drop of 0.6 inches of water through the socket and the anode cooler.

The air requirements stated above are based on operation at sea level and an ambient temperature of 20°C. Operation at high altitude or at high ambient temperatures requires a greater volume of air flow. The necessary design information for such conditions is contained in an article entitled "Blower Selection for Forced-Air-Cooled Tubes", by A. G. Nekut, in the August, 1950, issue of "Electronics."

One method of measuring temperature is provided by the use of the "Tempilaq", a temperature-sensitive lacquer, which melts when a given temperature is reached. Where forced-air cooling is employed, very thin applications of the lacquer must be used. This product is obtainable from the Tempil Corporation, 132 West 22nd St., New York 11, N. Y.

ELECTRICAL

Heater—The heater should be operated as close to 6.0 volts as possible, but it will withstand heater-voltage variations as great as 10% without injury. Some variation in power output must be expected to occur with variations of the heater voltage.

Cathode—The cathode is internally connected to the four even-numbered base pins. All four corresponding socket terminals should be used for connection to the external circuit. The leads should be of large cross-section and as short and direct as possible to minimize cathode-lead inductance.

Grid Dissipation—Grid-circuit driving-power requirements increase with increasing frequency because of circuit losses other than grid dissipation. This becomes noticeable at frequencies near 30 Mc., and increases until

at 500 Mc. as much as 30 watts driving power may be required in ordinary circuits.

Despite the increased driving power required by the circuit as a whole at higher frequencies, the power actually consumed by the tube grid does not increase greatly. Satisfactory operation in stable amplifier circuits is indicated by d-c grid-current values below approximately 15 milliamperes.

Screen Dissipation—Bias- or plate-supply failure or unloaded-plate-circuit operation can cause the screen current and dissipation to rise to excessive values. Protection for the screen can be provided by an overload relay in the screen circuit, in addition to the usual plate-overload relay. Use of a screen-current milliammeter is advisable.

Plate Dissipation—The maximum-rated plate dissipation is 150 watts. The maximum-rated plate dissipation for plate-modulated applications is 100 watts under carrier conditions, which permits the plate dissipation to rise to 150 watts under 100% sinusoidal modulation.

Plate dissipation may be permitted to exceed the maximum rating momentarily, as, for instance, during tuning.

UHF Operation—Transit time effects, which occur at ultra-high frequencies in the 4X150A, can be minimized by adherence to the operating conditions suggested below:

1. Use a minimum d-c bias voltage, not over twice cut-off.
2. Apply only enough drive to obtain satisfactory plate efficiency.
3. Operate the screen at reasonably high voltage, but do not exceed the screen-dissipation rating. The circuit should be loaded to obtain screen-current values close to those given under "Typical Operation" at 500 Mc.
4. Fairly heavy plate loading is required. In general, low-voltage, high-current operation is preferable to operation at high voltage and low current. If conditions require a change to lighter plate loading, the drive should also be reduced to the minimum value for satisfactory operation at the new output level.
5. Parasitic oscillations are usually associated with excessive grid and screen current and are injurious to vacuum tubes. Similarly, tuned-plate circuits which accidentally become simultaneously resonant to harmonics and the fundamental frequency may also cause low efficiency and damage tubes.

Plate Modulation—Plate modulation can be applied to the 4X150A when it is operated as a class-C radio-frequency amplifier. To obtain 100% modulation, the d-c screen voltage must be modulated approximately 55%, in phase with the plate modulation. Self-modulation of the screen by means of a series resistor or reactor may not be satisfactory in this particular tetrode due to the screen-voltage, screen-current characteristics.

Grid Resistance—In class-A and -AB₁ amplifiers, where no grid current flows, the grid-bias voltage may be applied through a resistor. The maximum permissible series resistance per tube is 100,000 ohms.

Special Applications—If it is desired to operate this tube under conditions widely different than those given here, write to Eitel-McCullough, Inc., San Bruno, California, for information and recommendations.

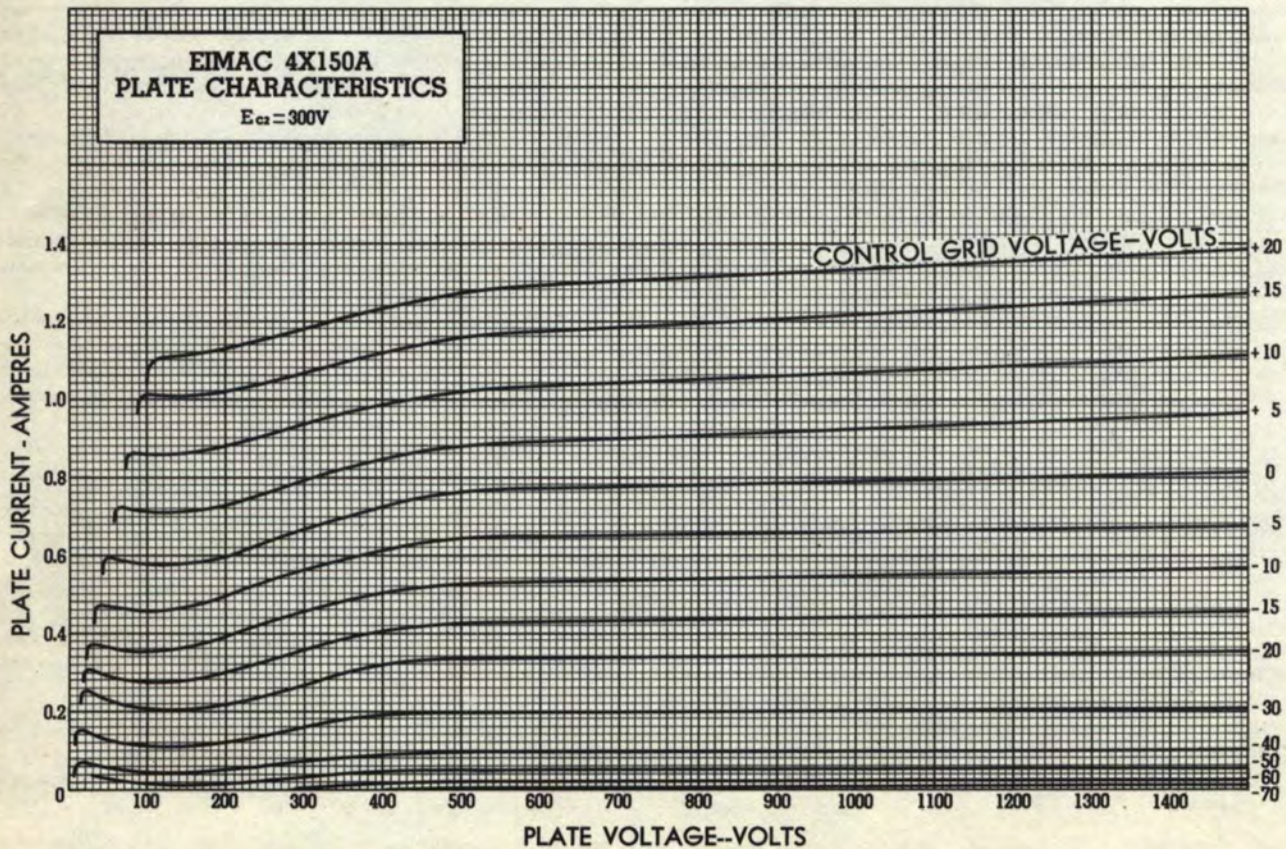
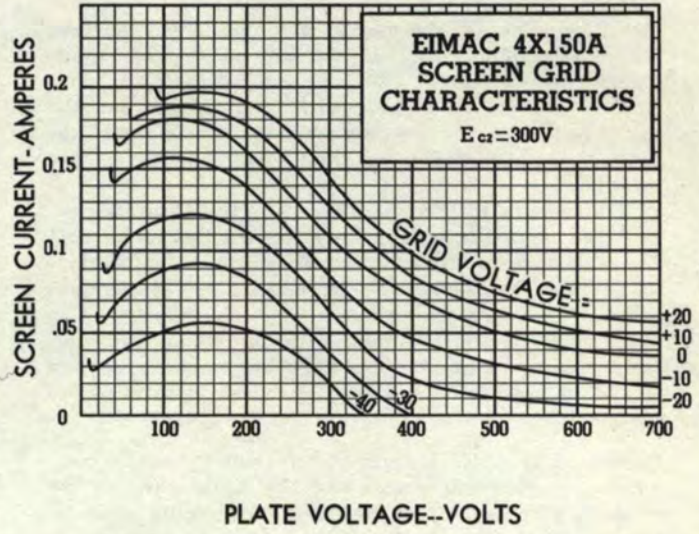
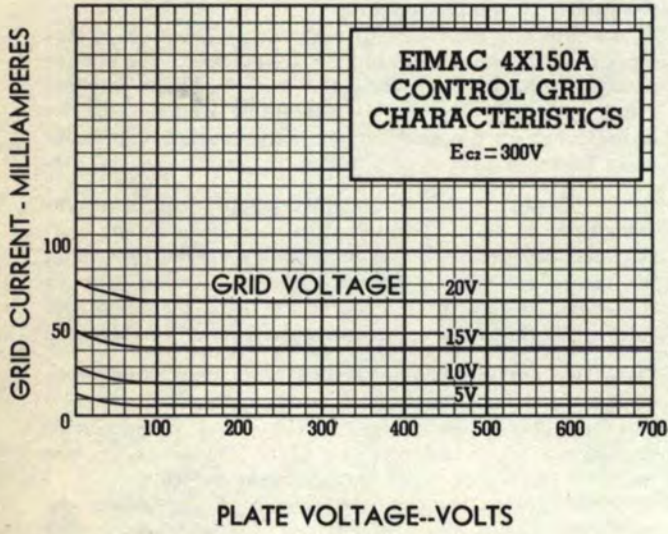

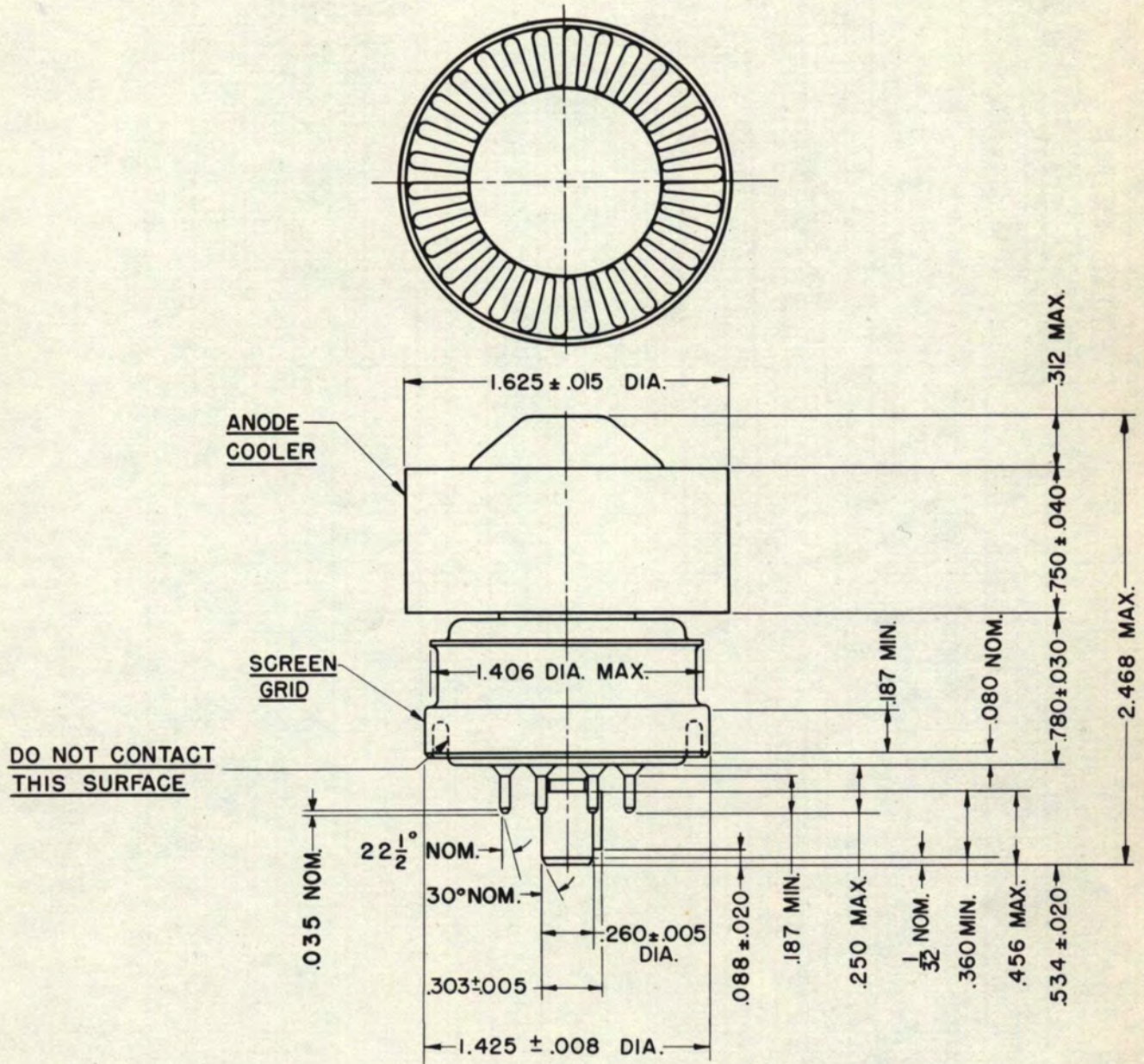

DO NOT CONTACT THIS SURFACE

ANODE COOLER

SCREEN GRID

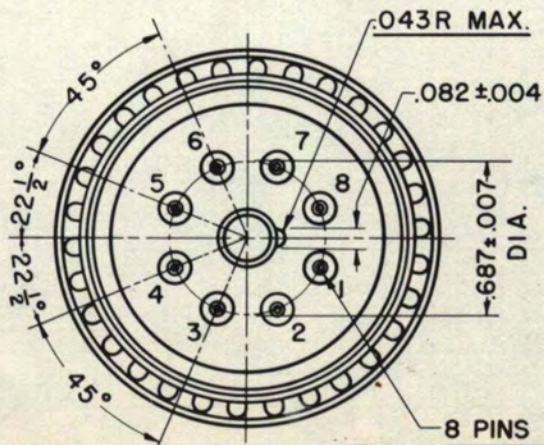

- PIN NO. 1 SCREEN GRID
- PIN NO. 2 CATHODE
- PIN NO. 3 HEATER
- PIN NO. 4 CATHODE
- PIN NO. 5 I.C. DO NOT USE FOR EXTERNAL CONNECTION
- PIN NO. 6 CATHODE
- PIN NO. 7 HEATER
- PIN NO. 8 CATHODE
- CENTER PIN-CONTROL GRID

DIMENSIONS IN INCHES

BOTTOM VIEW

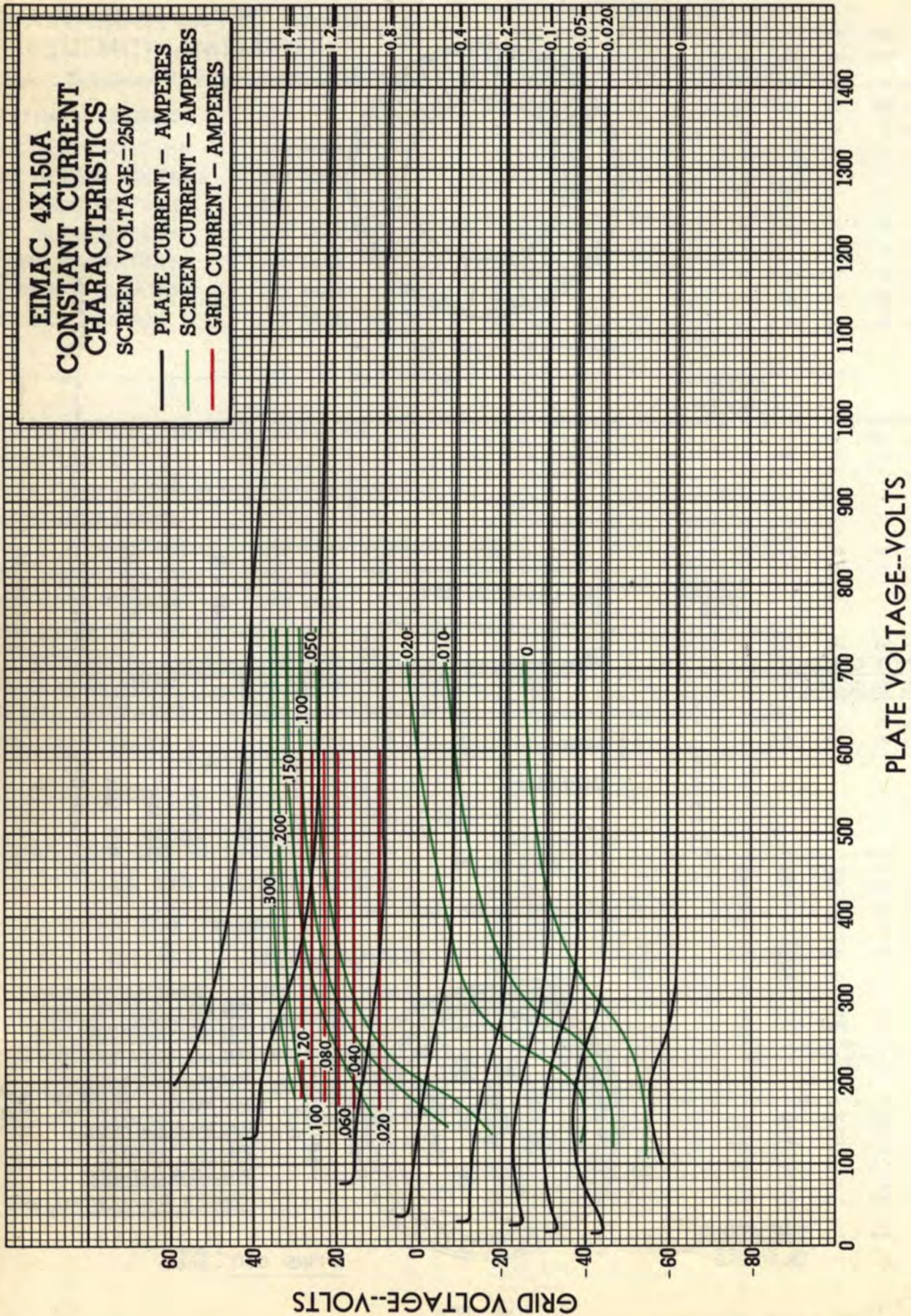

Eimac
EITEL-McCULLOUGH, INC.
 SAN BRUNO, CALIFORNIA

4X150A/4000
 AND
4X150A/4010
 AIR-SYSTEM
 SOCKETS

The Eimac 4X150A/4000 and 4X150A/4010 Air-System Sockets are designed to provide adequate air cooling and an efficient high-frequency circuit arrangement for the Eimac 4X150A and 4X150D tetrodes. The insulating materials used in their construction have very low r-f losses to well above 800 Mc., and are mechanically strong, non-porous, non-hygroscopic and substantially unaffected by temperatures up to 180° Centigrade. The contact fingers are of spring alloy and all metal parts are silver plated to reduce r-f losses.

The 4X150A/4000 Air-System Socket is characterized by having all connecting tabs insulated from the socket flange and skirt. This type socket is intended for use in circuits where the cathode of the tube is not at chassis potential.

The 4X150A/4010 Air-System Socket is characterized by having the four cathode connecting tabs (Numbers 2, 4, 6 and 8) riveted permanently to the socket skirt. This type socket is intended for use in circuits where the cathode of the tube is at chassis potential.

MOUNTING—If the tube and socket are to be used in a coaxial-line circuit, the Air-System Socket may be mounted directly on the end of the coaxial input line. The skirt of the socket fits over a cylinder of 1 1/8" outside diameter, and four mounting holes are provided (See Outline Drawings).

For chassis mounting, a 2 1/4" diameter hole should be cut into the deck and the socket secured by the three toe clamps provided.

DO NOT DRILL THROUGH THE SOCKET FLANGE.

CONNECTIONS—The control grid connection is on the axis of the socket and is provided with a No. 6-32 threaded hole for direct connection to a coaxial line or a terminal lug.

A low impedance path between screen grid and ground is provided by a bypass capacitor of from 2750 $\mu\mu\text{f}$ \pm 500 $\mu\mu\text{f}$ built into the socket flange.

COOLING—A pressurized chamber should be provided to introduce an air stream into the socket from the under side to cool the grid, cathode and screen seals. A heat-resistant chimney is provided to direct the air stream over the tube envelope and through the anode radiator.

If a coaxial-line circuit is used, the input line should be pressurized, while the output cavity should be made air tight to direct the air through the anode radiator of the tube.

For the specific cooling requirements of the 4X150A and 4X150D, see the paragraph on "Cooling" in the 4X150A Data Sheet.

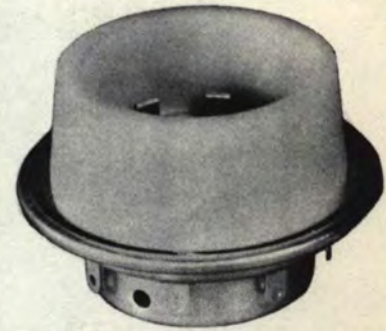

SOCKET IDENTIFICATION

TYPE NUMBER	DESCRIPTION
4X150A/4000 - - - - -	4X150A Air-System Socket with Chimney
4X150A/4001 - - - - -	4X150A Air-System Socket less Chimney
4X150A/4006 - - - - -	4X150A Air-System Chimney Only
4X150A/4010 - - - - -	4X150A Air-System Socket—Grounded Cathode—with Chimney
4X150A/4011 - - - - -	4X150A Air-System Socket—Grounded Cathode—less Chimney

(Effective 6-15-53) Copyright 1953 by Eitel-McCullough, Inc.

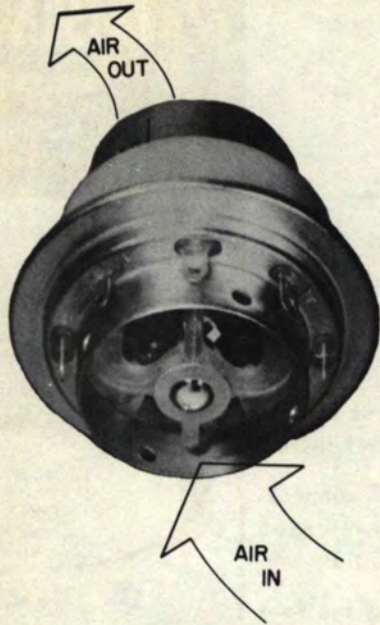

**4X150A/4000
with 4X150A**

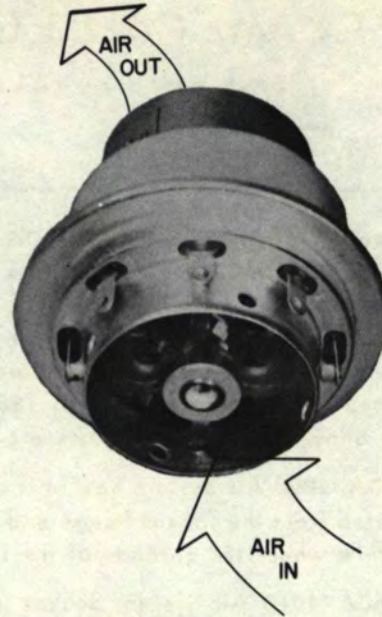

**4X150A/4010
with 4X150A**

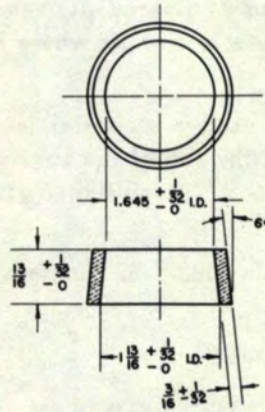

4X150A/4006

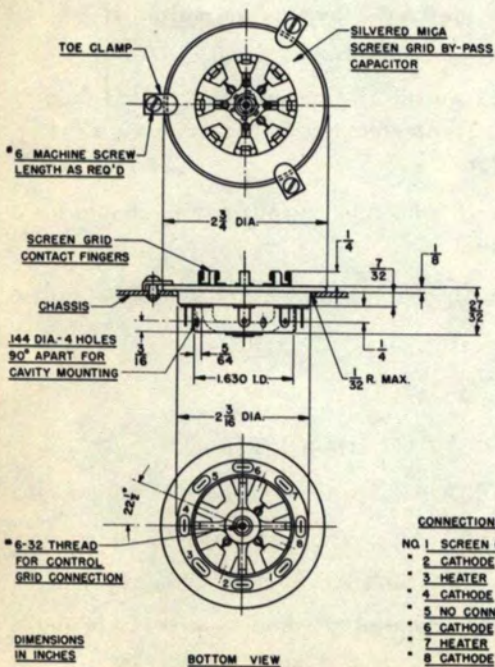

4X150A/4001

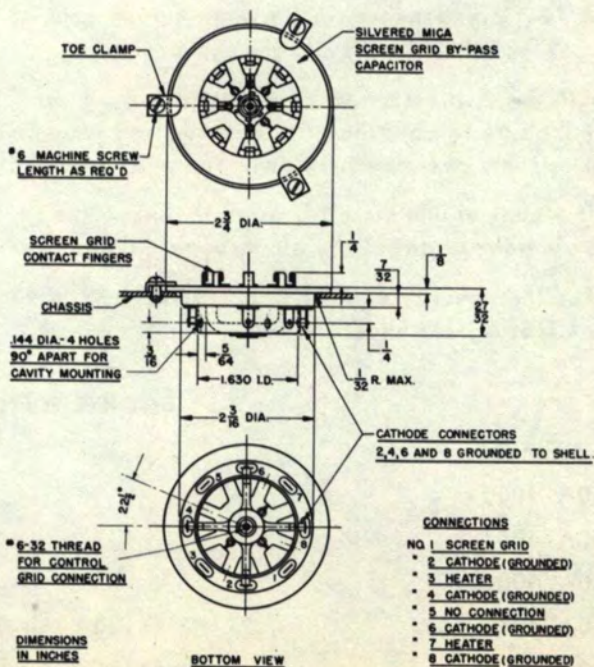

4X150A/4011

TENTATIVE DATA

Eimac
EITEL-McCULLOUGH, INC.
 SAN BRUNO, CALIFORNIA

4X150G
 RADIAL-BEAM
 POWER TRODE

The Eimac 4X150G is an extremely compact external-anode tetrode intended for use as a radio-frequency amplifier, frequency multiplier, or oscillator at frequencies well into the UHF region or as an amplifier in any service requiring a high-gain tube capable of delivering high power-output at low plate-voltage. The combination of a high ratio of transconductance to capacitance and a plate dissipation capability of 150 watts makes the tube an excellent wide-band amplifier for video applications.

The cathode, grid and screen electrodes are mounted on conical and cylindrical supports giving a minimum of circuit discontinuities and lead inductance. The rugged cylindrical terminals, progressively larger in size, allow the tube to be inserted in coaxial line cavities. The screen support and terminal provide maximum isolation between the grid cathode terminals and the plate circuit.

In amplifier service at 500 megacycles, output power of 140 watts per tube, with a stage power-gain of 20, can be obtained. At 1000 megacycles an output power of 50 watts per tube is obtained with a power-gain of five.

GENERAL CHARACTERISTICS

ELECTRICAL

Cathode: Coated Unipotential			
Heater Voltage	- - - - -	2.5	volts
Heater Current	- - - - -	6.25	amperes
Minimum Heating Time	- - - - -	30	seconds
Screen-Grid Amplification Factor (Average)	- - - - -		5.0
Direct Interelectrode Capacitances (Average)		Grounded Grid	
Grid-Plate (without shielding)	- - - - -	less than .005	.035 μmfd
Input	- - - - -	17.	27 μmfd
Output	- - - - -	4.5	4.5 μmfd
Transconductance ($i_b=250 \text{ ma.}, e_b=500 \text{ v.}, E_{c2}=250 \text{ V.}$)	- - - - -		12,000 μmhos

MECHANICAL

Cooling	- - - - -		Forced Air
At 150 watts plate dissipation, a minimum flow of 5.6 cubic feet of air per minute must be passed through the anode cooler. The pressure drop across the cooler at this flow equals 0.26 inches of water. Forced-air cooling of the base terminal assembly must be provided even though heater alone is on tube during standby conditions. In no case should the temperature of the metal-to-glass seals or the core of the anode cooler exceed 150° C.			
Mounting position	- - - - -		Any
Maximum Overall Dimensions			
Length	- - - - -		2 $\frac{5}{8}$ inches
Diameter	- - - - -		1.625±.020 inches
Maximum Seated Height	- - - - -		1-27/32 inches
Net Weight	- - - - -		6 ounces
Shipping Weight (Average)	- - - - -		1.6 pounds

RADIO FREQUENCY POWER AMPLIFIER OR OSCILLATOR

Class-C Telephony or FM Telephony (Key-down conditions, per tube)

MAXIMUM RATINGS

D-C PLATE VOLTAGE	- - - - -	1250 MAX. VOLTS
D-C SCREEN VOLTAGE	- - - - -	300 MAX. VOLTS
D-C GRID VOLTAGE*	- - - - -	-250 MAX. VOLTS
D-C PLATE CURRENT	- - - - -	250 MAX. MA.
PLATE DISSIPATION	- - - - -	150 MAX. WATTS
ANODE-COOLER CORE TEMPERATURE	- - - - -	150 MAX. °C
SCREEN DISSIPATION	- - - - -	15 MAX. WATTS
GRID DISSIPATION	- - - - -	2 MAX. WATTS

*Maximum permissible grid circuit resistance 25,000 ohms

TYPICAL OPERATION

Single tube, frequencies below 165-Mc.

D-C Plate Voltage	- - - - -	400	750	1000	1250	Volts
D-C Plate Current	- - - - -	200	200	200	200	Ma.
D-C Screen Voltage	- - - - -	250	250	250	250	Volts
D-C Screen Current	- - - - -	37	37	31	20	Ma.
D-C Grid Voltage	- - - - -	-75	-80	-80	-90	Volts
D-C Grid Current	- - - - -	11	11	10	11	Ma.
Peak R-F Grid Voltage (Approx.)	- - - - -	91	96	95	106	Volts
Driving Power (approx.)	- - - - -	1.0	1.1	1.0	1.2	Watts
Power Input	- - - - -	120	150	200	250	Watts
Power Output	- - - - -	85	110	150	195	Watts
Heater Voltage ¹	- - - - -	2.5	2.5	2.5	2.5	Volts

Single tube, 750-Mc. (Coaxial cavity)

D-C Plate Voltage	- - - - -	1250	Volts
D-C Plate Current	- - - - -	200	Ma.
D-C Screen Voltage	- - - - -	250	Volts
D-C Screen Current	- - - - -	5	Ma.
D-C Grid Voltage	- - - - -	-40	Volts
D-C Grid Current	- - - - -	5	Ma.
Peak R-F Grid Voltage (approx.)	- - - - -	85	Volts
Driving Power (approx.)	- - - - -	9	Watts
Power Input	- - - - -	250	Watts
Power Output	- - - - -	100	Watts
Heater Voltage ¹	- - - - -	See note	

(Effective 3-15-53) Copyright 1953 by Eitel-McCullough, Inc.

PLATE MODULATED RADIO FREQUENCY AMPLIFIER

Class-C Telephony

MAXIMUM RATINGS (Carrier Conditions)

D-C PLATE VOLTAGE	- - - - -	1000	MAX. VOLTS
D-C SCREEN VOLTAGE	- - - - -	300	MAX. VOLTS
D-C GRID VOLTAGE*	- - - - -	-250	MAX. VOLTS
D-C PLATE CURRENT	- - - - -	200	MAX. MA.
PLATE DISSIPATION	- - - - -	100	MAX. WATTS
ANODE-COOLER CORE TEMPERATURE	- - - - -	150	MAX. °C.
SCREEN DISSIPATION	- - - - -	15	MAX. WATTS
GRID DISSIPATION	- - - - -	2	MAX. WATTS

*Maximum permissible grid circuit resistance 25,000 ohms

PLATE PULSED RADIO FREQUENCY AMPLIFIER OR OSCILLATOR

MAXIMUM RATINGS

PULSED PLATE VOLTAGE	- - - - -	7000	MAX. VOLTS
PULSED SCREEN VOLTAGE	- - - - -	1500	MAX. VOLTS
D-C GRID VOLTAGE	- - - - -	-500	MAX. VOLTS
MAXIMUM PULSE DURATION	- - - - -	5	MICROSECONDS
PULSED CATHODE CURRENT	- - - - -	7	MAX. AMPS
AVERAGE POWER INPUT	- - - - -	250	MAX. WATTS
PLATE DISSIPATION	- - - - -	150	MAX. WATTS
ANODE-COOLER CORE TEMPERATURE	- - - - -	150	MAX. °C
SCREEN DISSIPATION	- - - - -	15	MAX. WATTS
GRID DISSIPATION	- - - - -	2	MAX. WATTS

TYPICAL PULSE OPERATION

Single tube oscillator, 1200-Mc.

Pulsed Plate Voltage	- - - - -	5	7	Kilovolts
Pulsed Plate Current	- - - - -	4.0	6.0	Amps.
Pulsed Screen Voltage	- - - - -	800	1000	Volts
Pulsed Screen Current	- - - - -	0.3	0.4	Amps.
D-C Grid Voltage	- - - - -	-200	-250	Volts
Pulsed Grid Current	- - - - -	0.5	0.6	Amps.
Pulse Duration	- - - - -	4	4	Microseconds
Pulse Repetition Rate	- - - - -	2500	1250	Per second
Peak Power Output	- - - - -	10	20	Kilowatts
Heater Voltage ¹	- - - - -			See Note ¹

¹Heater Voltage—Due to transit time back heating effects, the heater voltage should be reduced when operating at frequencies above 400 Mc. This voltage reduction should be made after dynamic operation of the tube has started. Since back heating is a function of frequency, grid current, grid bias, circuit design and circuit adjustment, the amount of back heating varies considerably with different methods of operation. The following table is an approximate guide for normal tube operation:

Frequency	up to 400 Mc.	400 to 1000 Mc.	1000 to 1500 Mc.	above 1500 Mc.
Heater Voltage	2.5 v	2.2 v	2.0 v	1.8 v



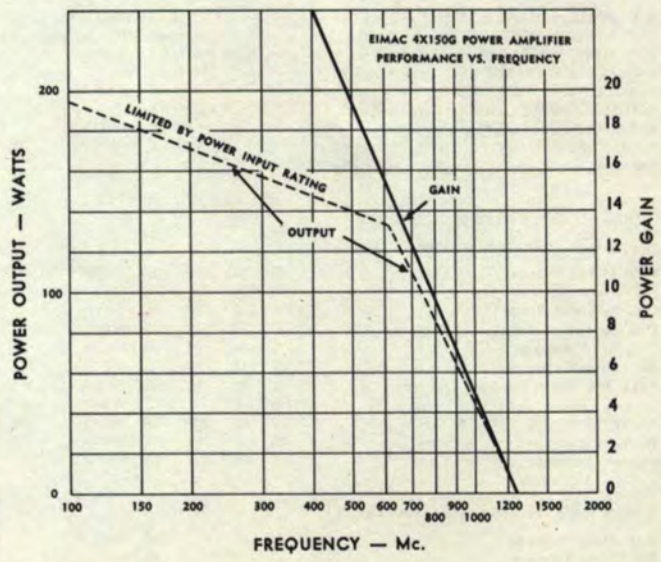
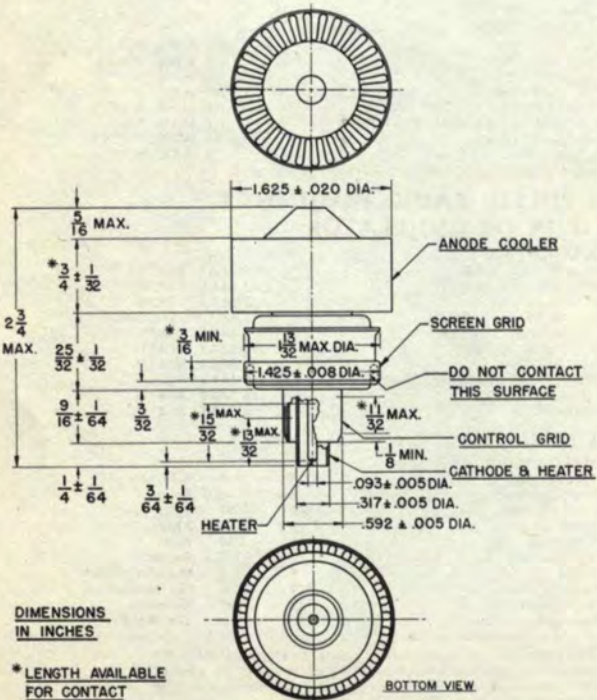
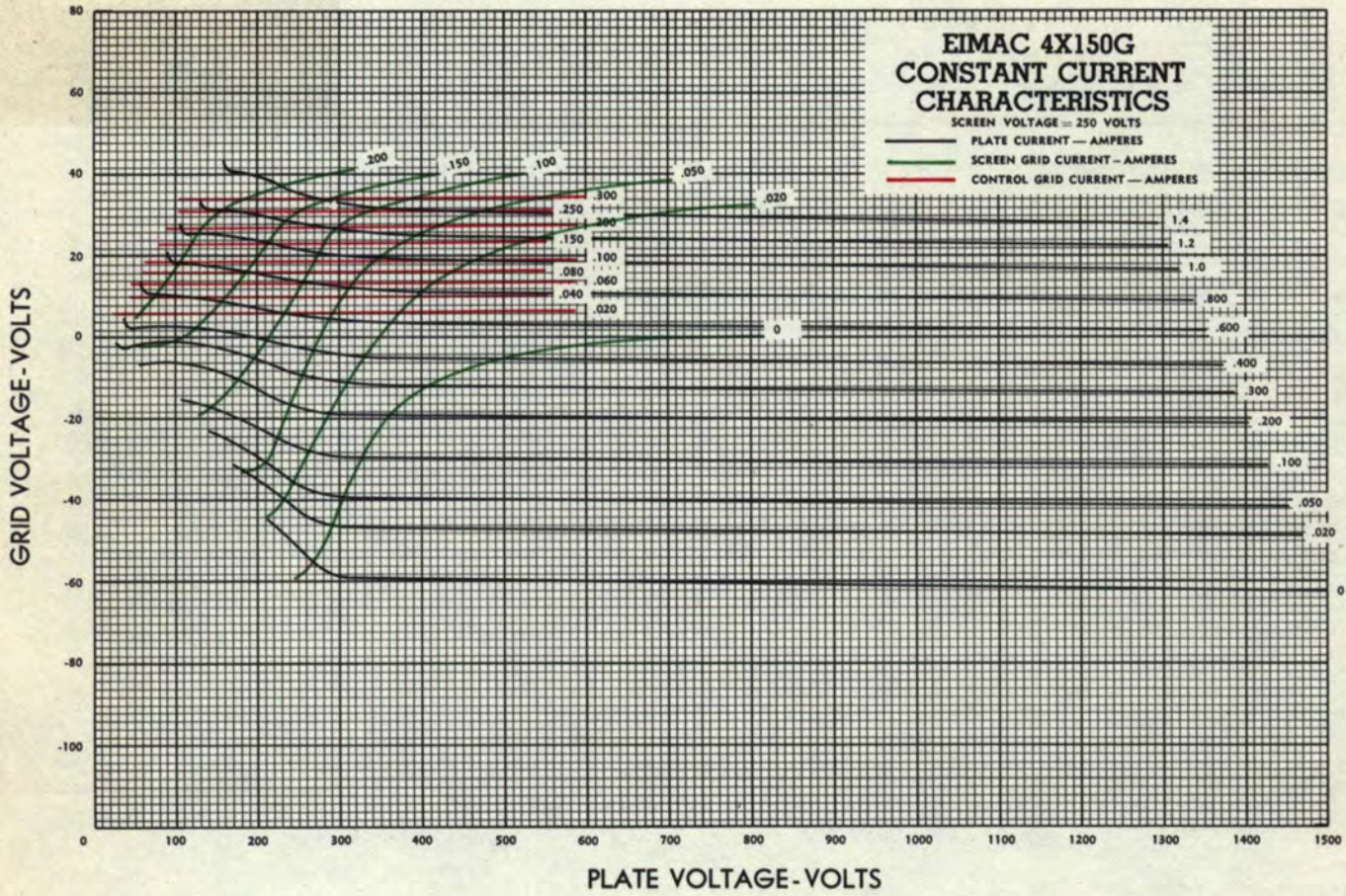

Eitel-McCullough, Inc.

SAN BRUNO, CALIFORNIA

4X500A

**RADIAL-BEAM
POWER TRODE**

The Eimac 4X500A is an external-anode tetrode having a maximum plate dissipation rating of 500 watts. Its small size and low-inductance leads permit efficient operation at relatively large outputs well into the VHF region. The screen grid is mounted on a disc which terminates in a connector ring located between grid and plate, thus making possible effective shielding between the grid and plate circuits. The grid terminal is located at the center of the glass base to facilitate single-tube operation in coaxial circuits.

The combination of low grid-plate capacitance, low screen-lead inductance and functionally located terminals contributes to the stable operation of the 4X500A at high frequencies, making neutralization unnecessary in most cases and greatly simplifying it in others.

GENERAL CHARACTERISTICS

ELECTRICAL

Filament: Thoriated Tungsten	
Voltage - - - - -	5.0 volts
Current - - - - -	13.5 amperes
Screen Grid Amplification Factor (Average) - - - - -	6.2
Direct Interelectrode Capacitances (Average)	
Grid-Plate - - - - -	0.05 μmfd
Input - - - - -	12.8 μmfd
Output - - - - -	5.6 μmfd
Transconductance ($i_b=200 \text{ ma.}, e_b=2500 \text{ v.}, E_{c2}=500 \text{ v.}$) - - - - -	5200 μmhos
Frequency for Maximum Ratings - - - - -	120 Mc.

MECHANICAL

Maximum Overall Dimensions:	
Length - - - - -	4.75 inches
Diameter - - - - -	2.625 inches
Net Weight - - - - -	1.17 pounds
Shipping Weight (Average) - - - - -	6 pounds
Mounting Position - - - - -	Vertical, base down or up
Cooling - - - - -	Forced Air

At 500 watts plate dissipation, a minimum air-flow of 40 cubic feet per minute must be passed through the anode cooler. The pressure drop across the cooler at this rate of flow equals 1.4 inches of water. Forced-air cooling must be provided for the base and screen seals. Normally, suitable amounts of air may be obtained from a small centrifugal blower directed at the seals. In no case should the temperature of the metal-to-glass seals or the core of the anode cooler exceed 150°C. Cooling air specified above must be applied to the seals and the anode cooler prior to the application of filament power and continued for three minutes after power is removed from the filament.



RADIO FREQUENCY POWER AMPLIFIER AND OSCILLATOR

Class-C FM or Telegraphy (Key-down conditions, 1 tube)
MAXIMUM RATINGS (Frequencies up to 120 Mc.)

D-C PLATE VOLTAGE - - - - -	4000 MAX. VOLTS
D-C SCREEN VOLTAGE - - - - -	500 MAX. VOLTS
D-C GRID VOLTAGE - - - - -	-500 MAX. VOLTS
D-C PLATE CURRENT - - - - -	350 MAX. MA.
PLATE DISSIPATION - - - - -	500 MAX. WATTS
SCREEN DISSIPATION - - - - -	30 MAX. WATTS
GRID DISSIPATION - - - - -	10 MAX. WATTS

TYPICAL OPERATION (Per tube, at 110 Mc.)

D-C Plate Voltage - - - - -	2500	3000	4000	Volts
D-C Plate Current - - - - -	310	310	315	Ma.
D-C Screen Voltage - - - - -	500	500	500	Volts
D-C Screen Current - - - - -	26	24	22	Ma.
D-C Grid Voltage - - - - -	-150	-150	-150	Volts
D-C Grid Current - - - - -	15	16	16	Ma.
Driving Power (approx.) - - - - -	5	5	5	Watts
Useful Power Output (approx.) - - - - -	475	600	835	Watts

RADIO FREQUENCY POWER AMPLIFIER

Class-B Linear Amplifier, Television Visual Service

MAXIMUM RATINGS FOR TV (Frequencies up to 220 Mc.)

D-C PLATE VOLTAGE - - - - -	3000 MAX. VOLTS
D-C PLATE CURRENT - - - - -	350 MAX. MA.
D-C SCREEN VOLTAGE - - - - -	500 MAX. VOLTS
PLATE DISSIPATION - - - - -	500 MAX. WATTS
SCREEN DISSIPATION - - - - -	30 MAX. WATTS
GRID DISSIPATION - - - - -	10 MAX. WATTS

TYPICAL OPERATION

(Per tube at peak synchronizing level, 5-Mc. bandwidth, assumed load resistance 3,000 ohms per tube.)¹

D-C Plate Voltage - - - - -	1850	2400	Volts
D-C Screen Voltage - - - - -	500	500	Volts
D-C Grid Voltage - - - - -	-100	-100	Volts
D-C Plate Current - - - - -	285	400 ¹	Ma.
D-C Screen Current (approx.) - - - - -	20	35	Ma.
D-C Grid Current (approx.) - - - - -	10	15	Ma.
Peak R-F Grid Voltage - - - - -	140	185	Volts
Driving Power, 220 Mc. (approx.) - - - - -	15	25	Watts
Plate Power Input - - - - -	525	960	Watts
Power Output - - - - -	300	600	Watts

BLACK LEVEL

D-C Plate Current - - - - -	215	300	Ma.
D-C Screen Current - - - - -	2	3	Ma.
D-C Grid Current - - - - -	2	5	Ma.
Plate Power Input - - - - -	400	720	Watts
Plate Dissipation - - - - -	230	380	Watts
Power Output - - - - -	170	340	Watts

¹ Operating conditions at peak synchronizing level may be permitted to exceed maximum ratings of the tube because of the low duty factor. Maximum ratings apply to black level conditions.

Eimac

REG. U. S. PAT. OFF.
4X500A

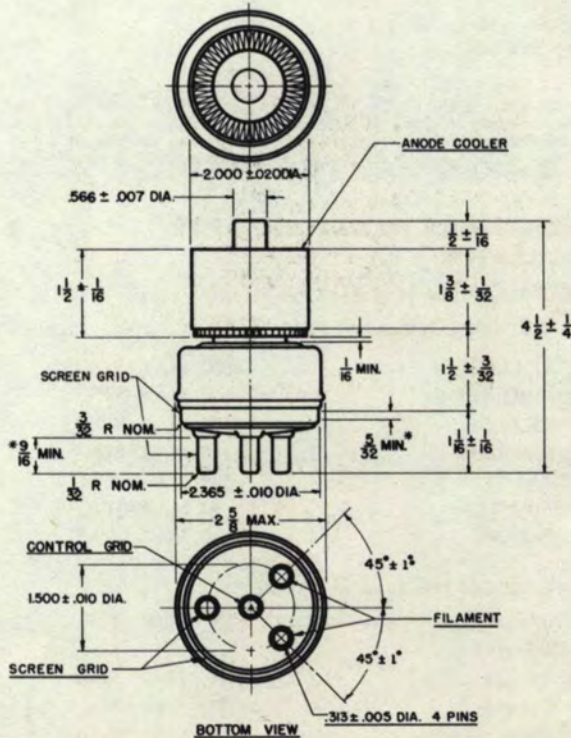
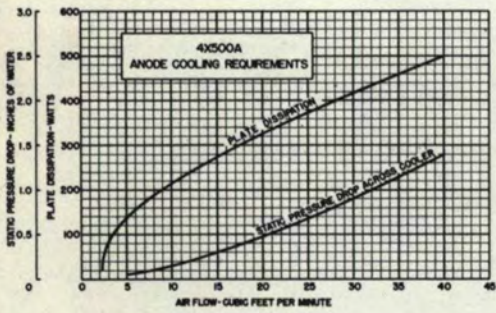
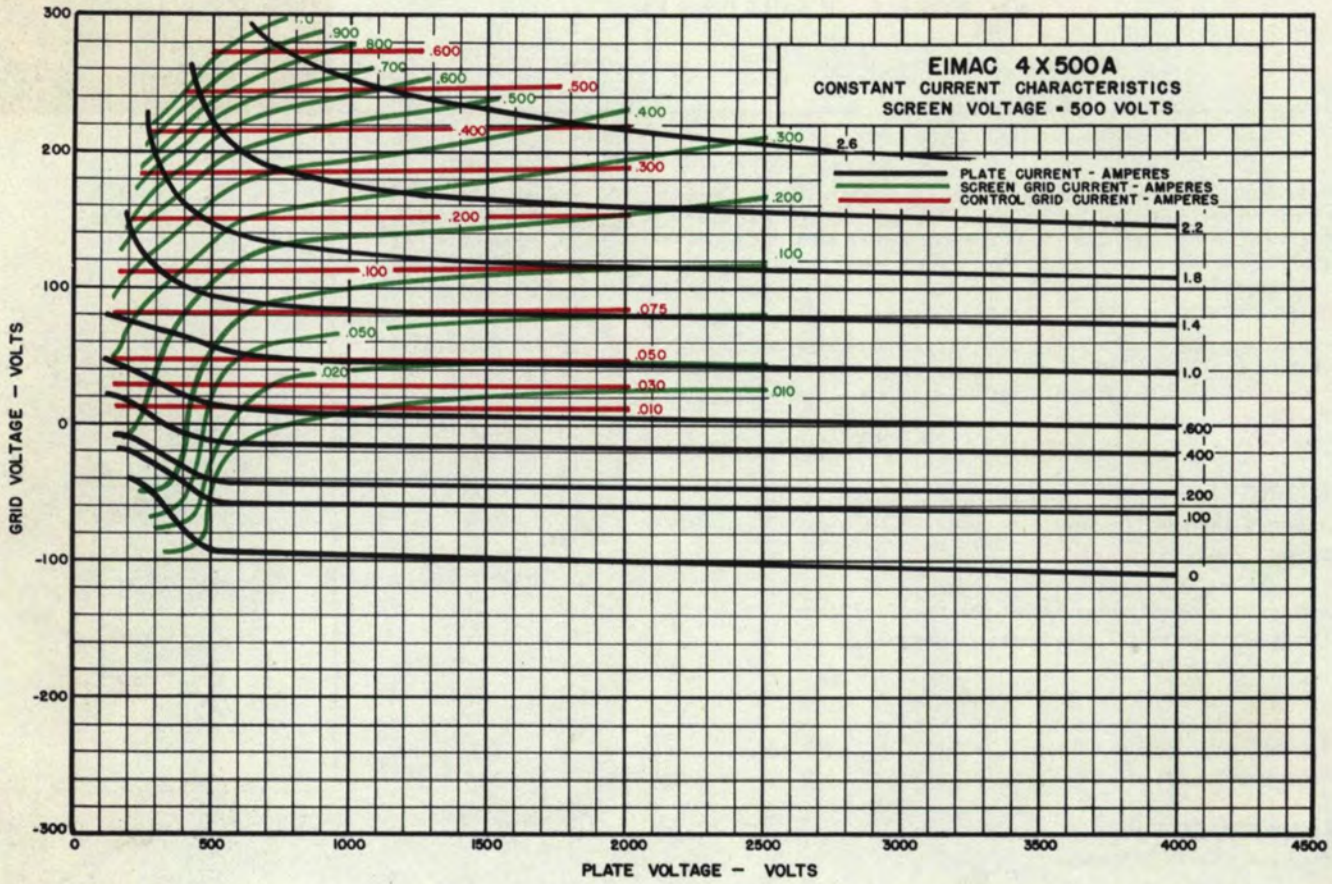

DIMENSIONS
IN INCHES

* STRAIGHT SIDE
AVAILABLE FOR
CONTACT

Eitel-McCULLOUGH, INC.

SAN BRUNO, CALIFORNIA

4E27A/5-125B

RADIAL-BEAM
POWER PENTODE

MODULATOR
OSCILLATOR
AMPLIFIER

The Eimac 4E27A/5-125B is a power pentode intended for use as a modulator, oscillator or amplifier. The driving-power requirement is very low, and neutralization problems are simplified or eliminated entirely. The tube has a maximum plate-dissipation rating of 125 watts and a maximum plate voltage rating of 4000 volts at frequencies up to 75 Mc. Cooling is by convection and radiation. Type 4E27A/5-125B unilaterally replaces type 4E27.

The 4E27A/5-125B in class-C r-f service will deliver up to 375 watts plate power output with less than 2 watts driving power. It will deliver up to 75 watts of carrier for suppressor modulation.

Two 4E27A/5-125B's will deliver up to 300 watts maximum-signal plate power output in class AB₁ modulator service, 400 watts in class AB₂ with less than 1 watt driving power.

GENERAL CHARACTERISTICS

ELECTRICAL

Filament: Thoriated tungsten	
Voltage	5.0 volts
Current	7.5 amperes
Grid-Screen Amplification Factor (Average)	5.0
Direct Interelectrode Capacitances (Average)	
Grid-Plate	0.08 μ fd
Input	10.5 μ fd
Output	4.7 μ fd
Transconductance ($I_b=50$ ma., $E_b=2500$ v., $E_{c2}=500$ v., $E_{c3}=0$ v.)	2150 μ mhos
Highest Frequencies for Maximum Ratings	75 Mc.

MECHANICAL

Base	7-pin, metal shell
Connections	See drawing
Socket*	E. F. Johnson Co. No. 122-237, or equivalent
Mounting Position	Vertical, base down or up
Cooling	Convection and radiation
Recommended Heat Dissipating Plate Connector	Eimac HR-5
Maximum Over-All Dimensions:	
Length	6.19 inches
Diameter	2.75 inches
Net Weight (Average)	6.0 ounces
Shipping Weight	2.0 pounds

*See "Cooling" under Application Notes.

Note: Typical operation data are based on conditions of adjusting to a specified plate current, maintaining fixed conditions of grid bias, screen voltage, suppressor voltage and r-f grid voltage. It will be found that if this procedure is followed, there will be little variation in power output between tubes even though there may be some variation in grid, screen and suppressor currents. Where grid bias is obtained principally by means of a grid resistor, to control plate current it is necessary to make the resistor adjustable.

RADIO-FREQUENCY POWER AMPLIFIER OR OSCILLATOR

Class-C Telegraphy or FM Telephony, Frequencies up to 75 Mc.
(Key-down conditions, per tube)

MAXIMUM RATINGS

D-C PLATE VOLTAGE	4000 MAX. VOLTS
D-C SCREEN VOLTAGE	750 MAX. VOLTS
D-C GRID VOLTAGE	-500 MAX. VOLTS
D-C PLATE CURRENT	200 MAX. MA
PLATE DISSIPATION	125 MAX. WATTS
SUPPRESSOR DISSIPATION	20 MAX. WATTS
SCREEN DISSIPATION	20 MAX. WATTS
GRID DISSIPATION	5 MAX. WATTS

TYPICAL OPERATION

60 Suppressor Volts, 500 Screen Volts						
D-C Plate Voltage	1000	1500	2000	2500	3000	volts
D-C Grid Voltage	-120	-130	-150	-170	-200	volts
D-C Plate Current	167	200	200	186	167	ma
D-C Suppressor Current*	6	5	4	3	3	ma
D-C Screen Current*	11	11	11	7	5	ma
D-C Grid Current*	6	8	8	7	6	ma
Peak R-F Grid Input Voltage	170	200	222	240	260	volts
Driving Power*	1.0	1.6	1.8	1.7	1.6	watts
Grid Dissipation*	.3	.6	.6	.5	.6	watts
Screen Dissipation*	5.5	5.5	5.5	3.5	2.5	watts
Plate Dissipation	47	85	100	115	125	watts
Plate Power Input	167	300	400	465	500	watts
Plate Power Output	120	215	300	350	375	watts

TYPICAL OPERATION

Zero Suppressor Volts, 500 Screen Volts						
D-C Plate Voltage	1000	1500	2000	2500	3000	volts
D-C Grid Voltage	-120	-130	-150	-170	-200	volts
D-C Plate Current	145	180	200	184	167	ma
D-C Screen Current*	17	20	23	18	12	ma
D-C Grid Current*	6	8	11	9	7	ma
Peak R-F Grid Input Voltage	170	200	240	250	270	volts
Driving Power*	1.0	1.6	2.6	2.3	1.9	watts
Grid Dissipation*	.3	.6	1.0	.8	.5	watts
Screen Dissipation*	8.5	10	12	9	6	watts
Plate Dissipation	55	95	125	125	125	watts
Plate Power Input	145	270	400	460	500	watts
Plate Power Output	90	175	275	335	375	watts

TYPICAL OPERATION

Zero Suppressor Volts, 750 Screen Volts						
D-C Plate Voltage	1000	1500	2000	2500	3000	volts
D-C Grid Voltage	-170	-180	-200	-225	-250	volts
D-C Plate Current	160	200	200	186	167	ma
D-C Screen Current*	21	24	22	12	9	ma
D-C Grid Current*	3	6	6	4	3	ma
Peak R-F Grid Input Voltage	205	235	257	270	290	volts
Driving Power*	.6	1.4	1.5	1.1	.9	watts
Grid Dissipation*	.1	.4	.3	.2	.2	watts
Screen Dissipation*	16	18	17	9	7	watts
Plate Dissipation	45	85	100	115	125	watts
Plate Power Input	160	300	400	465	500	watts
Plate Power Output	115	215	300	350	375	watts

*Approximate Values





4E27A/5-125B

PLATE-MODULATED RADIO-FREQUENCY AMPLIFIER

Class-C Telephony, Frequencies up to 75 Mc.
(Carrier conditions, per tube, unless otherwise specified)

MAXIMUM RATINGS

D-C PLATE VOLTAGE	- - -	3200 MAX. VOLTS
D-C SCREEN VOLTAGE	- - -	750 MAX. VOLTS
D-C GRID VOLTAGE	- - -	-500 MAX. VOLTS
D-C PLATE CURRENT	- - -	160 MAX. MA
PLATE DISSIPATION	- - -	85 MAX. WATTS
SUPPRESSOR DISSIPATION	- - -	20 MAX. WATTS
SCREEN DISSIPATION	- - -	20 MAX. WATTS
GRID DISSIPATION	- - -	5 MAX. WATTS

TYPICAL OPERATION

Zero Suppressor Volts, 500 Screen Volts						
D-C Plate Voltage	- - - -	1000	1500	2000	2500	volts
D-C Grid Voltage	- - - -	-190	-195	-200	-205	volts
D-C Plate Current	- - - -	149	150	151	152	ma
D-C Screen Current*	- - - -	20	18	17	16	ma
D-C Grid Current*	- - - -	7	7	8	8	ma
Peak A-F Screen Voltage	- - - -	-	-	-	-	volts
(100% Modulation)	- - - -	350	350	350	350	volts
Peak R-F Grid Input Voltage	- - - -	260	265	270	275	volts
Driving Power*	- - - -	2	2	2	2	watts
Grid Dissipation*	- - - -	0.5	0.5	0.5	0.5	watts
Screen Dissipation*	- - - -	10	9	8.5	8	watts
Plate Dissipation	- - - -	64	72	80	85	watts
Plate Power Input	- - - -	149	225	300	380	watts
Plate Power Output	- - - -	85	153	220	295	watts

SUPPRESSOR-MODULATED RADIO-FREQUENCY AMPLIFIER

Class-C Telephony, Frequencies up to 75 Mc.
(Carrier conditions, per tube, unless otherwise specified)

MAXIMUM RATINGS

D-C PLATE VOLTAGE	- - -	4000 MAX. VOLTS
D-C SCREEN VOLTAGE	- - -	750 MAX. VOLTS
D-C GRID VOLTAGE	- - -	-500 MAX. VOLTS
D-C PLATE CURRENT	- - -	200 MAX. MA
PLATE DISSIPATION	- - -	125 MAX. WATTS
SUPPRESSOR DISSIPATION	- - -	20 MAX. WATTS
SCREEN DISSIPATION	- - -	20 MAX. WATTS
GRID DISSIPATION	- - -	5 MAX. WATTS

TYPICAL OPERATION

D-C Plate Voltage	- - - -	1500	2000	2500	3000	volts
D-C Suppressor Voltage	- - - -	-220	-260	-305	-350	volts
Peak A-F Suppressor Voltage	- - - -	-	-	-	-	volts
(100% Modulation)	- - - -	220	260	305	350	volts
D-C Screen Voltage	- - - -	400	400	400	400	volts
Fixed D-C Screen Voltage	- - - -	610	645	650	610	volts
Screen Dropping Resistor ¹	- - - -	5500	9100	10,000	8300	ohms
D-C Grid Voltage	- - - -	-170	-180	-190	-200	volts
D-C Plate Current	- - - -	59	59	59	60	ma
D-C Screen Current*	- - - -	38	27	25	25	ma
D-C Grid Current*	- - - -	6	5	5	4	ma
Peak R-F Grid Input Voltage	- - - -	230	235	245	250	volts
Driving Power*	- - - -	1.4	1.3	1.2	1.2	watts
Grid Dissipation*	- - - -	.35	.25	.25	.20	watts
Screen Dissipation*	- - - -	15	11	10	10	watts
Plate Dissipation	- - - -	54	68	87	105	watts
Plate Power Input	- - - -	89	118	148	180	watts
Plate Power Output	- - - -	35	50	61	75	watts

¹Adjust to stated d-c screen voltage.

AUDIO-FREQUENCY POWER AMPLIFIER OR MODULATOR

Class-AB, Sinusoidal Wave

MAXIMUM RATINGS (Per Tube)

D-C PLATE VOLTAGE	- - -	4000 MAX. VOLTS
D-C SCREEN VOLTAGE	- - -	750 MAX. VOLTS
D-C GRID VOLTAGE	- - -	-500 MAX. VOLTS
D-C PLATE CURRENT	- - -	200 MAX. MA
PLATE DISSIPATION	- - -	125 MAX. WATTS
SUPPRESSOR DISSIPATION	- - -	20 MAX. WATTS
SCREEN DISSIPATION	- - -	20 MAX. WATTS
GRID DISSIPATION	- - -	5 MAX. WATTS

TYPICAL OPERATION (Two tubes unless otherwise specified)

Class-AB ₁					
D-C Plate Voltage	- - - -	1500	2000	2500	volts
D-C Suppressor Voltage	- - - -	0	0	0	volts
D-C Screen Voltage	- - - -	500	500	500	volts
D-C Grid Voltage ¹	- - - -	-70	-80	-85	volts
Zero-Signal D-C Plate Current	- - - -	110	85	65	ma
Max-Signal D-C Plate Current	- - - -	205	210	220	ma
Zero-Signal D-C Screen Current*	- - - -	0	0	0	ma
Max-Signal D-C Screen Current*	- - - -	15	13	8	ma
Effective Plate-to-Plate Load	- - - -	13,700	18,000	20,000	ohms
Peak A-F Grid Voltage (per tube)	- - - -	70	80	85	volts
Max-Signal Driving Power*	- - - -	0	0	0	watts
Max-Signal Plate Power Input	- - - -	310	420	550	watts
Max-Signal Plate Power Output	- - - -	200	250	300	watts

¹Adjust to stated zero-signal d-c plate current. The effective grid circuit resistance for each tube must not exceed 250,000 ohms.

TYPICAL OPERATION (Two tubes unless otherwise specified)

Class-AB ₂					
D-C Plate Voltage	- - - -	1500	2000	2500	volts
D-C Suppressor Voltage	- - - -	60	0	0	volts
D-C Screen Voltage	- - - -	500	500	500	volts
D-C Grid Voltage ¹	- - - -	-70	-80	-85	volts
Zero-Signal D-C Plate Current	- - - -	110	85	65	ma
Max-Signal D-C Plate Current	- - - -	365	295	250	ma
Zero-Signal D-C Screen Current*	- - - -	0	0	0	ma
Max-Signal D-C Screen Current*	- - - -	11	16	13	ma
Effective Plate-to-Plate Load	- - - -	7300	13,000	20,000	ohms
Peak A-F Grid Input Voltage (per tube)	- - - -	100	100	95	volts
Max-Signal Driving Power*	- - - -	0.5	0.3	0.2	watts
Max-Signal Plate Power Input	- - - -	550	590	625	watts
Max-Signal Plate Power Output	- - - -	300	350	400	watts

¹Adjust to stated zero-signal d-c plate current.

*Approximate values.

IF IT IS DESIRED TO OPERATE THIS TUBE UNDER CONDITIONS WIDELY DIFFERENT FROM THOSE GIVEN UNDER "TYPICAL OPERATION", POSSIBLY EXCEEDING THE MAXIMUM RATINGS GIVEN FOR CW SERVICE, WRITE EITEL-McCULLOUGH, INC., FOR INFORMATION AND RECOMMENDATIONS.

APPLICATION

MECHANICAL

Mounting—The 4E27A/5-125B must be mounted vertically, base down or up. The plate lead should be flexible, and the tube must be protected from vibration and shock.

Cooling—A heat dissipating connector (Eimac HR-5 or equivalent) is required at the plate terminal, and provision must be made for the free circulation of air through the socket and through the holes in the base. If the E. F. Johnson Co. 122-237 socket recommended under "General Characteristics" is to be used, the model incorporating a ventilating hole should be specified.

At high ambient temperatures, at frequencies above 75 Mc., or when the flow of air is restricted, it may become necessary to provide forced air circulation in sufficient quantity to prevent the temperature of the plate and base seals from exceeding 225°C. Forced movement of air across the tube seals and envelope is always beneficial, though not necessarily required.

Tube temperatures may be measured with the aid of "Tempilaq," a temperature-sensitive lacquer manufactured by the Tempil Corporation, 132 West 22nd Street, New York 11, N. Y.

ELECTRICAL

Filament Voltage—For maximum tube life the filament voltage, as measured directly at the base pins, should be the rated value of 5.0 volts. Variations should be held within the range of 4.75 to 5.25 volts.

Grid Voltage—Although a maximum of —500 volts bias may be applied to the grid, there is little advantage in using bias voltages in excess of those listed under "Typical Operation," except in certain specialized applications.

When grid-leak bias is used, suitable protective means must be provided to prevent excessive plate dissipation in the event of loss of excitation, and the grid-leak resistor should be made adjustable to facilitate maintaining the bias voltage and plate current at the desired value from tube to tube.

In class-C operation, particularly at high frequency, both grid bias and grid drive should be only great enough to provide satisfactory operation at good plate efficiency.

Screen Dissipation—Decrease or removal of plate load, plate voltage or bias voltage may result in screen dissipation in excess of the 20 watt maximum rating. The tube may be protected by an overload relay in the screen circuit set to remove the screen voltage when the dissipation exceeds 20 watts.

Resistors placed in the screen circuit for the purpose of developing an audio modulating voltage on the screen in modulated radio-frequency amplifiers should be made variable to permit adjustment when replacing tubes.

Plate Dissipation—Plate dissipation in excess of the 125-watt maximum rating is permissible for short periods of time, such as during tuning procedures.

Operation—If reasonable precautions are taken to prevent coupling between the input and output circuits, the 4E27A/5-125B may usually be operated at frequencies up to 75 Mc. without neutralization. A conventional method of obtaining the necessary shielding between the grid and plate circuits is to use a suitable metal chassis with the grid circuit mounted below the deck and the plate circuit above. The tube socket should be mounted flush with the under side of the chassis deck, and spring fingers mounted around the socket opening should make contact between the chassis and the metal base shell of the tube. Power-supply leads entering the amplifier should be bypassed to ground and properly shielded. The output circuit and antenna feeders should be arranged so as to preclude any possibility of feedback to other circuits.

Feedback at high frequencies may be due to the inductance of leads, particularly those of the screen and suppressor-grids. By-passing methods and means of placing these grids at r-f ground potential are discussed in Application Bulletin Number Eight, "The Care and Feeding of Power Tetrodes," available from Eitel-McCullough, Inc., for twenty-five cents. Much of the material contained in this bulletin may be applied to pentodes.

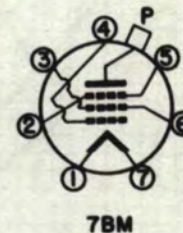
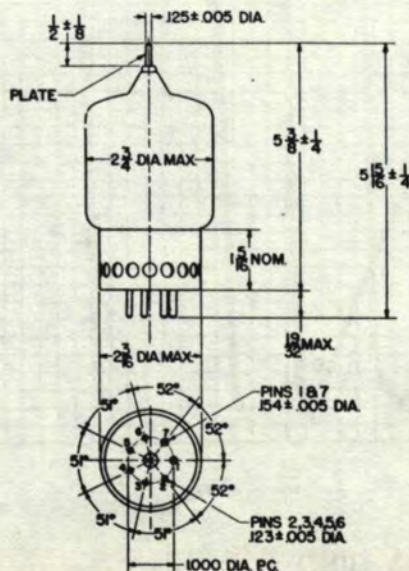

**EIMAC 4E27A/5-125B
 CONSTANT CURRENT
 CHARACTERISTICS**

SCREEN VOLTAGE = 500 VOLTS
 SUPPRESSOR VOLTAGE = 0 VOLTS

— PLATE CURRENT - AMPERES
 — SCREEN CURRENT - AMPERES
 — GRID CURRENT - AMPERES

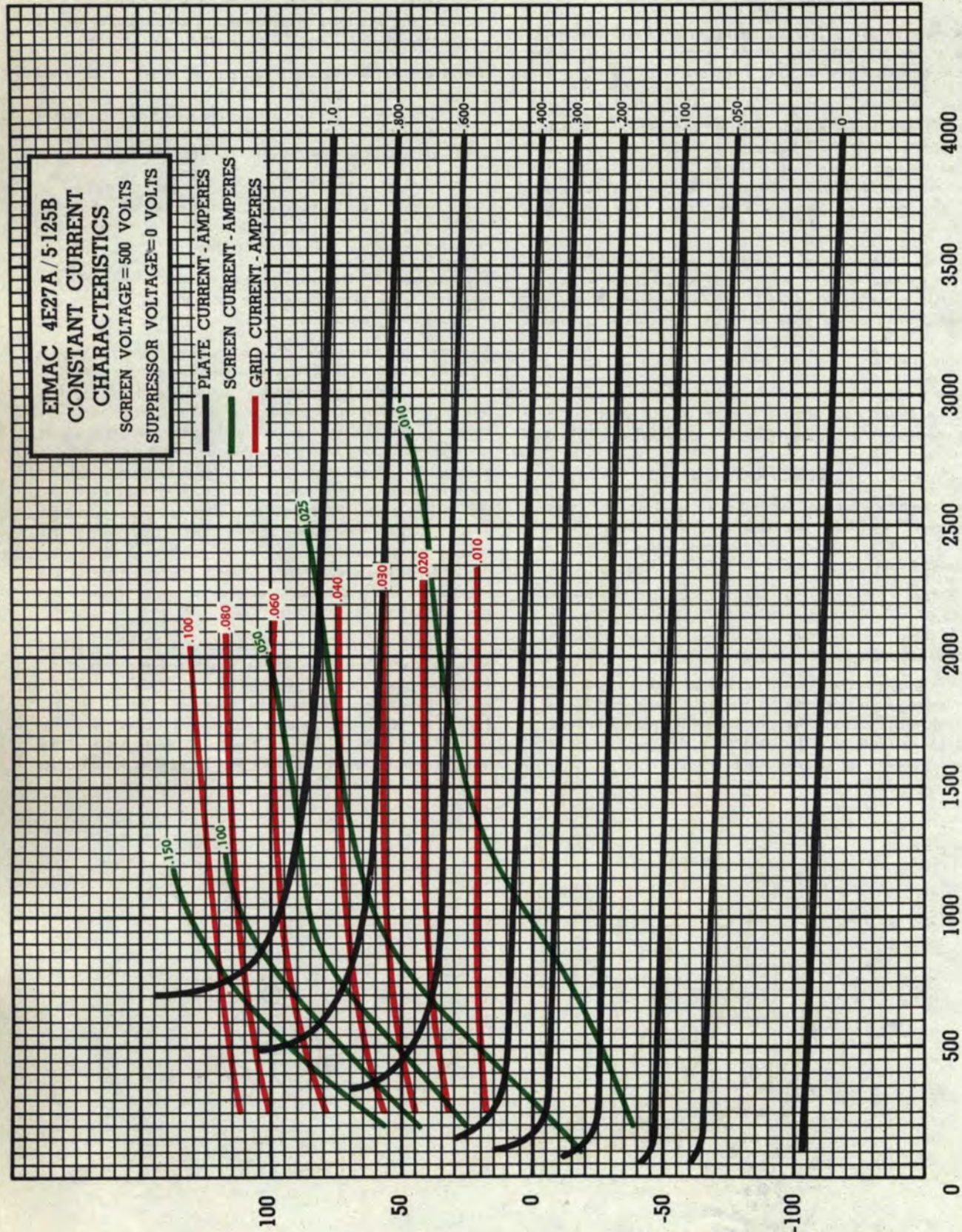
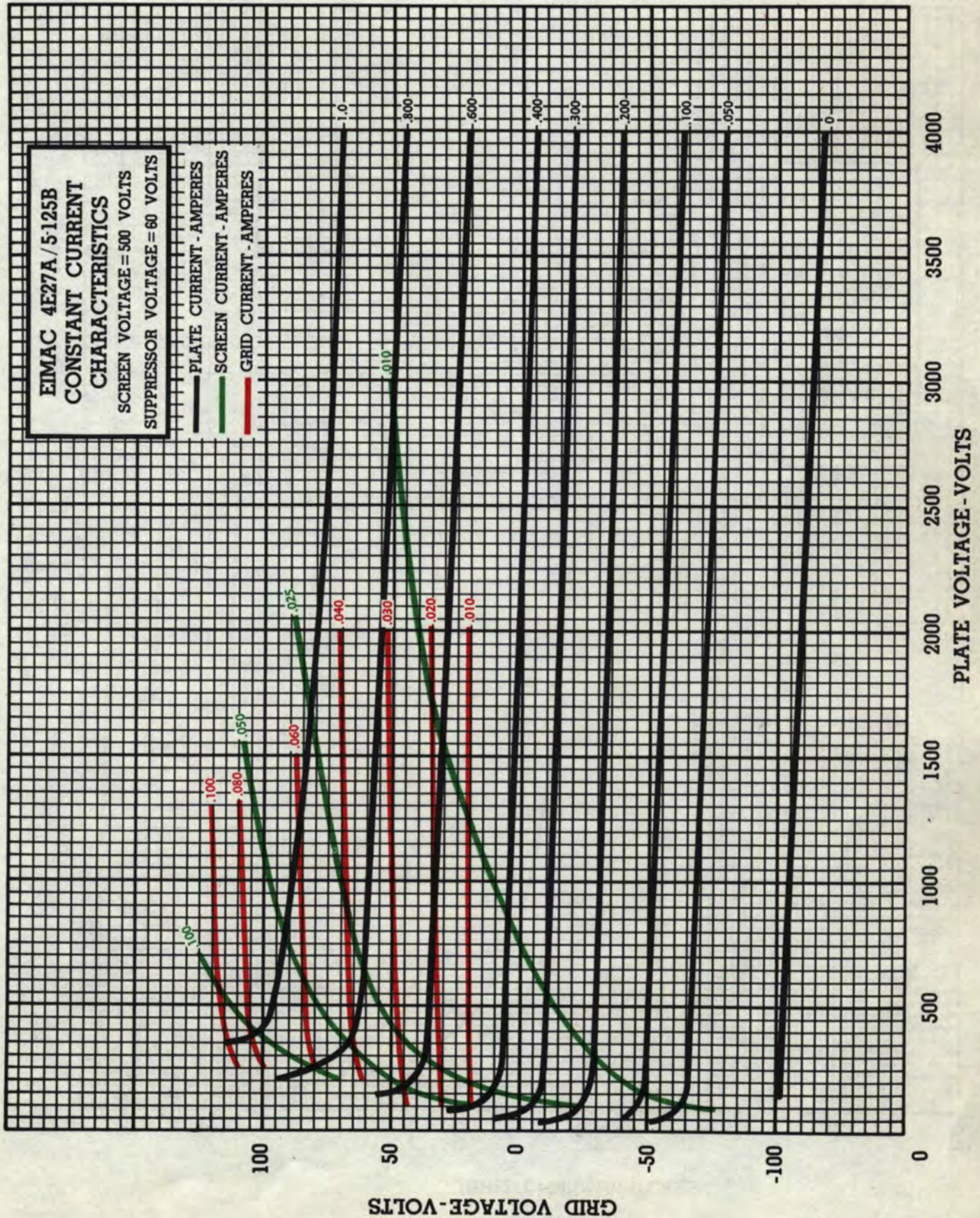
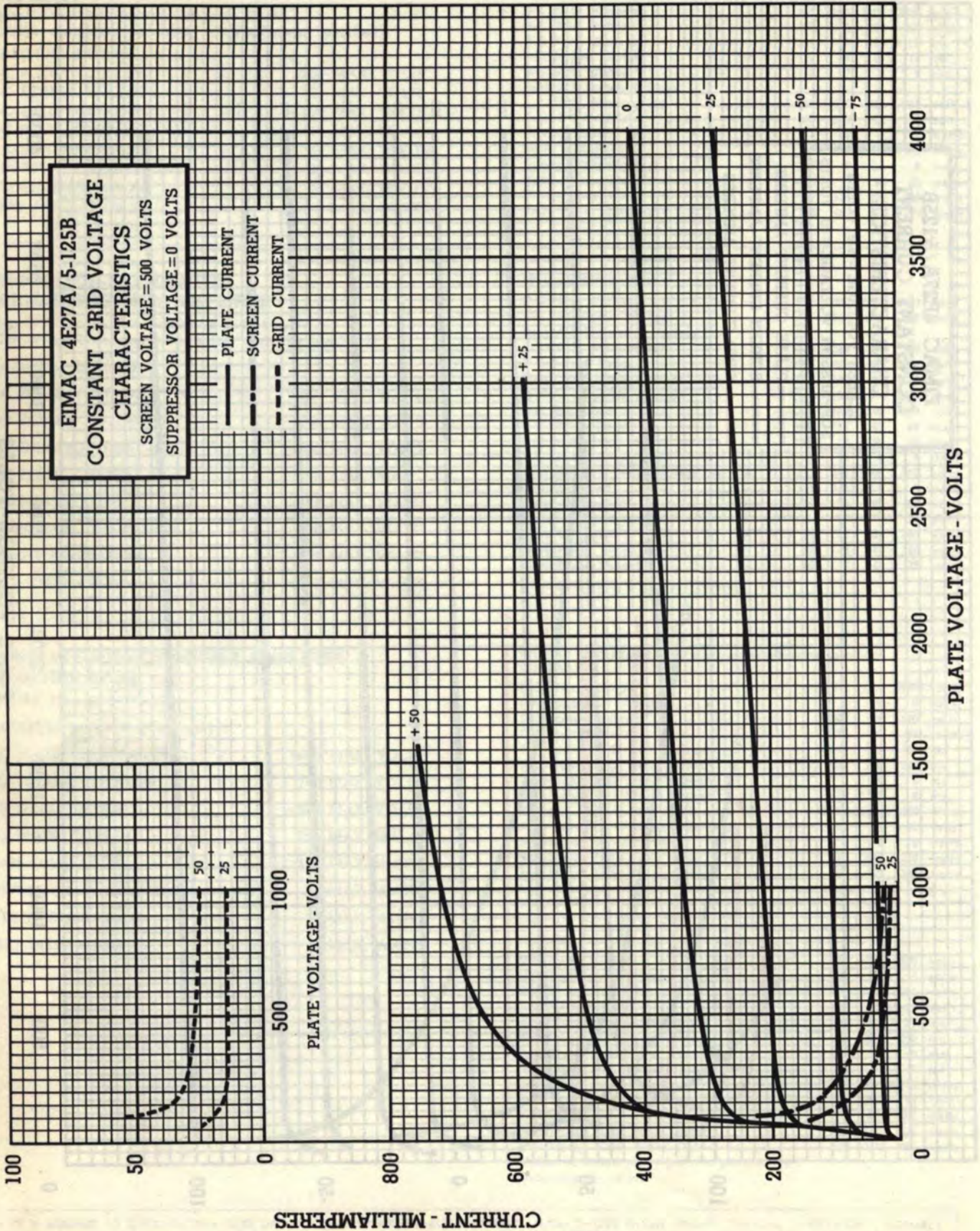

PLATE VOLTAGE - VOLTS





EITEL-McCULLOUGH, INC.

SAN BRUNO, CALIFORNIA

2C39A

HIGH-MU TRIODE

Supersedes
Types
2C38 - 2C39

The Eimac 2C39A is a high-mu UHF transmitting triode with a plate-dissipation rating of 100 watts, designed for use as a power amplifier, oscillator, or frequency multiplier at frequencies to above 2500 Mc. The rugged construction, small size and unusually high transconductance of this tube make it ideal for compact fixed or mobile equipment. Its physical characteristics are particularly suitable for grid-isolation circuits and for cavity-type circuits.

The 2C39A in a class-C r-f grid-isolation circuit at 500 Mc. will deliver up to 27 watts useful power output with 6 watts driving power. As an r-f oscillator at 2500 Mc., the 2C39A will deliver a minimum of 12 watts useful power output.

GENERAL CHARACTERISTICS

ELECTRICAL

Cathode: Coated Unipotential	
Heater Voltage ¹	6.3 volts
Heater Current	1.0 ampere
Amplification Factor (Average)	100
Direct Interelectrode Capacitances (Average)	
Grid-Plate	1.95 μmf
Grid-Cathode	6.50 μmf
Plate-Cathode	0.035 μmf max.
Transconductance ($I_b = 70\text{ma.}, E_b = 600\text{v.}$)	22,000 μmhos
Highest Frequency for Maximum Ratings	2500 Mc.

¹See "Application".

MECHANICAL

Base, Socket and Connections	See drawing
Mounting Position	Any
Cooling	Forced air
Maximum Temperature of Anode, Grid, Cathode and Heater Seals and Anode Cooler Core	175°C
Maximum Overall Dimensions:	
Length	2.75 inches
Diameter	1.26 inches
Net Weight	2.8 ounces
Shipping Weight (Average)	7 ounces

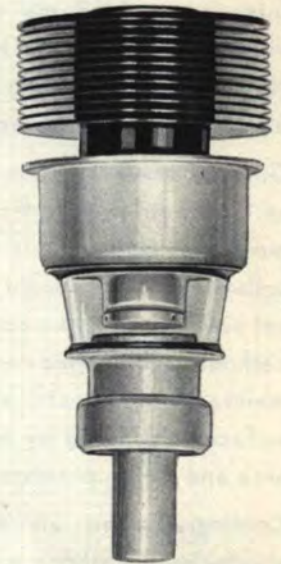

RADIO-FREQUENCY POWER AMPLIFIER, OSCILLATOR OR MODULATOR

MAXIMUM RATINGS (Per tube)

D-C PLATE VOLTAGE	1000 MAX. VOLTS
D-C CATHODE CURRENT	125 MAX. MA
D-C GRID VOLTAGE	-150 MAX. VOLTS
D-C GRID CURRENT	50 MAX. MA
HEATER VOLTAGE	SEE APPLICATION NOTES
INSTANTANEOUS PEAK POSITIVE GRID VOLTAGE	
	30 MAX. VOLTS
INSTANTANEOUS PEAK NEGATIVE GRID VOLTAGE	
	400 MAX. VOLTS
PLATE DISSIPATION	100 MAX. WATTS
GRID DISSIPATION	2 MAX. WATTS

TYPICAL OPERATION (Key-down conditions, per tube) (Power-Amplifier Grid-Isolation Circuit, CW Operation, 500 Mc.)

D-C Plate Voltage	800 volts
D-C Grid Voltage	-20 volts
D-C Plate Current	80 ma
D-C Grid Current	32 ma
Driving Power (approx.) ¹	6 watts
Useful Power Output	27 watts

TYPICAL OPERATION

(R-F Oscillator, 2500 Mc.)²

D-C Plate Voltage	900 volts
D-C Grid Voltage	-22 volts
D-C Plate Current	90 ma
D-C Grid Current	27 ma
Useful Power Output	12 watts

PLATE-MODULATED RADIO-FREQUENCY AMPLIFIER OR OSCILLATOR

MAXIMUM RATINGS (Carrier conditions, per tube)

D-C PLATE VOLTAGE ³	600 MAX. VOLTS
D-C GRID VOLTAGE	-150 MAX. VOLTS
D-C GRID CURRENT	50 MAX. MA
D-C CATHODE CURRENT	100 MAX. MA
PEAK INSTANTANEOUS POSITIVE GRID VOLTAGE	
	30 MAX. VOLTS
PEAK INSTANTANEOUS NEGATIVE GRID VOLTAGE	
	400 MAX. VOLTS
PLATE DISSIPATION	70 MAX. WATTS
GRID DISSIPATION	2 MAX. WATTS

TYPICAL OPERATION

(Plate-Modulated Radio-Frequency Power Amplifier Grid-Isolation Circuit, 500 Mc., Per Tube)

D-C Plate Voltage	600 volts
D-C Grid Voltage	-16 volts
D-C Plate Current	75 ma
D-C Grid Current	40 ma
Driving Power (approx.) ¹	6 watts
Useful Carrier Power Output	18 watts

¹Driving power listed is the total power which must be supplied to a practical grid circuit at the frequency shown.

²These 2500-Mc. conditions conform to the minimum requirements of the JAN-1A specifications for the 2C39A.

³For less than 100% modulation, higher d-c plate voltage may be used if the sum of the peak positive modulating voltage and the d-c plate voltage does not exceed 1200 volts.

IF IT IS DESIRED TO OPERATE THIS TUBE UNDER CONDITIONS WIDELY DIFFERENT FROM THOSE GIVEN UNDER "TYPICAL OPERATION", POSSIBLY EXCEEDING THE MAXIMUM RATINGS GIVEN FOR CW SERVICE, WRITE EITEL-McCULLOUGH, INC., FOR INFORMATION AND RECOMMENDATIONS.

APPLICATION

MECHANICAL

Mounting—The 2C39A may be operated in any position. It should seat against the "anode flange" (see outline drawing), and any clamping action intended to hold the tube in its socket against vibration should also be applied to this flange. No seating or clamping pressure should be exerted against any other surface.

Connections—The tube terminals are in the form of concentric cylinders having graduated diameters, as illustrated in the outline drawing. Spring collets or fingers should be fitted to these cylindrical surfaces to make contact with the anode, grid, cathode and heater terminals. It is important to maintain good electrical contact by keeping these surfaces clean and by providing adequate contact area and spring pressure.

Cooling—Forced air must be supplied to the anode, grid, cathode and heater seals and to the anode cooler core in sufficient quantities to limit their temperatures to 175°C. A convenient accessory for the measurement of tube temperatures is "Tempilaq", a temperature-sensitive lacquer manufactured by the Tempil Corporation, 132 West 22nd St., New York 11, N. Y.

A suitable arrangement for an anode cooling cowl is shown in conjunction with the outline drawing. For operation at maximum rated dissipation, an air flow through this cowl of 12.5 cubic feet per minute is recommended; less cooling air may be used at low plate dissipations, provided only that seal and anode cooler core temperatures are not allowed to exceed 175°C.

At ambient temperatures greater than 25°C., or at altitudes higher than sea level, more air will be required to accomplish equivalent cooling. Further information on this subject is contained in an article by A. G. Nekut, "Blower Selection for Forced-Air Cooled Tubes", *Electronics*, August, 1950.

ELECTRICAL

Heater Voltage—The heater of the 2C39A is designed to be operated at 6.3 volts, with variations

held within the range of 5.7 to 6.9 volts. This operating voltage is particularly recommended for pulse applications requiring in excess of 3.0 amperes of peak cathode current.

Tube life may be materially increased by operation of the heater at 5.3 volts, with variations held within the range of 4.8 to 5.8 volts. This operating voltage should be used whenever the peak cathode current is not required to exceed 3.0 amperes, and whenever transit-time effects contribute back heating to the cathode. Back heating is a function of frequency, grid bias and excitation (grid current), load impedance, power output and circuit design and adjustment.

Cavity Circuits—Information regarding the design of cavities suitable for the 2C39A is widely available. One source is the material on cavity design for the 2C38 and 2C39 contained in "Very High Frequency Techniques", Radio Research Laboratory Staff, McGraw-Hill Co., 1947, Vol. 1, Chapter 15, pp. 337-375.

Operation—Low-voltage, high-current operation is preferable to high-voltage, low-current operation, from the standpoint of optimum tube life.

An excellent indication of operating conditions is the ratio of grid current to plate current; when the 2C39A is operated with grid-current values greater than half those of the plate current, either the drive is excessive or the plate loading is too light for the excitation present. The tube should never be operated without a load, or lightly loaded, even for short periods of time, and drive should be held to the lowest value consistent with reasonable efficiency.

When grid-leak bias is used, suitable means must be provided to protect the tube against loss of excitation at plate voltages in excess of 800 volts, and the grid-leak resistor should be made variable to facilitate maintaining the bias voltage and plate current at the desired values when tubes are changed in the equipment.

**EIMAC 2C39A
 CONSTANT CURRENT
 CHARACTERISTICS**

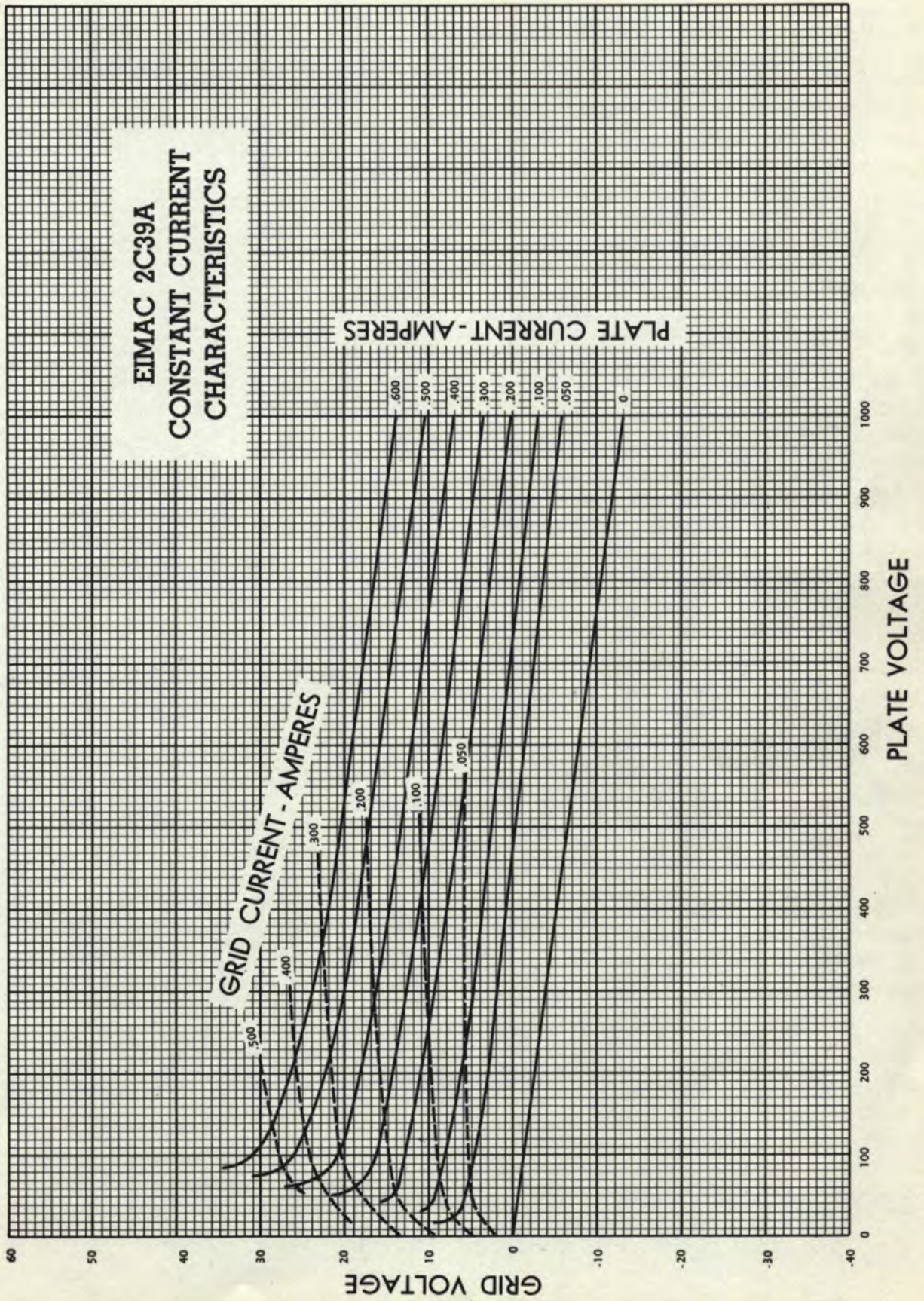

Eitel-McCullough, Inc.

SAN BRUNO, CALIFORNIA

3X2500A3

MEDIUM-MU TRIODE

The Eimac 3X2500A3 is a medium-mu, forced-air-cooled, external-anode transmitting triode with a maximum plate-dissipation rating of 2500 watts. Relatively high power output as an amplifier, oscillator or modulator may be obtained from this tube at low plate voltages. A single tube will deliver a radio-frequency output of 7500 watts at 4000 plate volts at frequencies up to 110 Mc., as well as at lower frequencies.

The tube has a rugged, low-inductance cylindrical filament-stem structure, which readily becomes part of a linear filament tank circuit for V.H.F. operation. The grid provides thorough shielding between the input and output circuits for grounded-grid applications, and is conveniently terminated in a ring between the plate and filament terminals. As a result of the use of unique grid- and filament-terminal arrangements, it is possible to install or remove the 3X2500A3 without the aid of tools.

The approved Federal Communications Commission rating for the 3X2500A3 as a plate-modulated amplifier is 5000 watts of carrier power.

GENERAL CHARACTERISTICS

ELECTRICAL

Filament: Thoriated tungsten	
Voltage	7.5 volts
Current	51 amperes
Amplification Factor (Average)	20
Direct Interelectrode Capacitances (Average)	
Grid-Plate	20 μ fd
Grid-Filament	36 μ fd
Plate-Filament	1.2 μ fd
Transconductance ($I_b = 830$ ma., $E_b = 3000$ v.)	20,000 μ hos
Highest Frequencies for Maximum Ratings	75 Mc

MECHANICAL

Base		see drawing
Mounting		Vertical, base down or up
Cooling		Forced air
Maximum Anode Cooler Core and Seal Temperatures		150°C
Maximum Over-All Dimensions:		
Length		9.0 inches
Diameter		4.156 inches
Net Weight		6.25 pounds
Shipping Weight (Average)		17 pounds



RADIO-FREQUENCY POWER AMPLIFIER OR OSCILLATOR

(Conventional Neutralized Amplifier—Frequencies below 75 Mc.)
Class-C FM or Telegraphy (Key-down conditions, per tube)

MAXIMUM RATINGS	
D-C PLATE VOLTAGE	6000 MAX. VOLTS
D-C PLATE CURRENT	2.5 MAX. AMPS
PLATE DISSIPATION	2500 MAX. WATTS
PLATE COOLER CORE TEMPERATURE	150 MAX. °C
GRID DISSIPATION*	150 MAX. WATTS

TYPICAL OPERATION (Frequencies below 75 Mc., per tube)

D-C Plate Voltage	4000	5000	6000	volts
D-C Plate Current	2.5	2.5	2.08	amps
D-C Grid Voltage	-300	-450	-500	volts
D-C Grid Current	245	265	180	ma
Peak R-F Grid Input Voltage	580	750	765	volts
Driving Power (approx.)	142	197	136	watts
Grid Dissipation	68	78	46	watts
Plate Power Input	10,000	12,500	12,500	watts
Plate Dissipation	2500	2500	2500	watts
Plate Power Output	7500	10,000	10,000	watts

RADIO-FREQUENCY POWER AMPLIFIER

Grounded-Grid Circuit
Class-C FM Telephony

MAXIMUM RATINGS (Frequencies between 85 and 110 Mc.)	
D-C PLATE VOLTAGE	4000 MAX. VOLTS
D-C PLATE CURRENT	2.0 MAX. AMPS
D-C GRID CURRENT*	200 MAX. MA
PLATE DISSIPATION	2500 MAX. WATTS
PLATE COOLER CORE TEMPERATURE	150 MAX. °C
GRID DISSIPATION*	150 MAX. WATTS

TYPICAL OPERATION (110 Mc., per tube)

D-C Plate Voltage	3700	4000	volts
D-C Grid Voltage	-450	-500	volts
D-C Plate Current	1.8	1.85	amps
D-C Grid Current	190	190	ma
Driving Power (approx.)	1600	1900	watts
Useful Power Output	6850	7500	watts

PLATE-MODULATED RADIO-FREQUENCY AMPLIFIER

(Conventional Neutralized Amplifier—Frequencies below 75 Mc.)
Class-C Telephony (Carrier conditions, per tube)

MAXIMUM RATINGS	
D-C PLATE VOLTAGE	5000 MAX. VOLTS
D-C PLATE CURRENT	2.0 MAX. AMPS
PLATE DISSIPATION	1670 MAX. WATTS
PLATE COOLER CORE TEMPERATURE	150 MAX. °C
GRID DISSIPATION	150 MAX. WATTS

TYPICAL OPERATIONS (Frequencies below 75 Mc., per tube)

D-C Plate Voltage	4000	4500	5000	volts
D-C Plate Current	1.67	1.55	1.45	amps
Total Bias Voltage	-450	-500	-550	volts
Fixed Bias Voltage	-230	-325	-410	volts
Grid Resistor	1500	1500	1400	ohms
D-C Grid Current	150	120	100	ma
Peak R-F Grid Input Voltage	680	720	760	volts
Driving Power (approx.)	102	84	74	watts
Grid Dissipation	35	26	21	watts
Plate Power Input	6670	6970	7250	watts
Plate Dissipation	1670	1670	1670	watts
Plate Power Output	5000	5300	5580	watts

IF IT IS DESIRED TO OPERATE THIS TUBE UNDER CONDITIONS WIDELY DIFFERENT FROM THOSE GIVEN UNDER "TYPICAL OPERATION", POSSIBLY EXCEEDING THE MAXIMUM RATINGS GIVEN FOR CW SERVICE, WRITE EITEL-McCULLOUGH, INC., FOR INFORMATION AND RECOMMENDATIONS.

AUDIO-FREQUENCY POWER AMPLIFIER AND MODULATOR

Class B (Sinusoidal wave, two tubes unless otherwise specified)

MAXIMUM RATINGS			
D-C PLATE VOLTAGE	- - - - -	6000	MAX. VOLTS
MAX.-SIGNAL D-C PLATE CURRENT, PER TUBE	- - - - -	2.5	MAX. AMPS
PLATE DISSIPATION, PER TUBE	- - - - -	2500	MAX. WATTS
PLATE COOLER CORE TEMPERATURE	- - - - -	150	MAX. ° C

TYPICAL OPERATION CLASS AB₂ (Two tubes)

D-C Plate Voltage	- - - - -	4000	5000	6000	volts
D-C Grid Voltage (approx.)*	- - - - -	-150	-190	-240	volts
Zero-Signal D-C Plate Current	- - - - -	0.6	0.5	0.4	amps
Max.-Signal D-C Plate Current	- - - - -	4.0	3.2	3.0	amps
Effective Load, Plate to Plate	- - - - -	2200	3600	4650	ohms
Peak A-F Grid Input Voltage (per tube)	- - - - -	340	340	390	volts
Max.-Signal Peak Driving Power	- - - - -	340	230	225	watts
Max.-Signal Nominal Driving Power (approx.)	- - - - -	170	115	113	watts
Max.-Signal Plate Power Output	- - - - -	11,000	11,000	13,000	watts

TYPICAL OPERATION CLASS AB₂ (Two tubes)

(Modulator service for 4000 and 5000 volt operation, to modulate one or two tubes, as shown under "Plate Modulated Radio Frequency Amplifier.")

D-C Plate Voltage	- - - - -	4000	5000	4000	5000	volts
D-C Grid Voltage (approx.)*	- - - - -	-155	-200	-145	-190	volts
Zero-Signal D-C Plate Current	- - - - -	0.4	0.4	0.6	0.5	amps
Max.-Signal D-C Plate Current	- - - - -	1.35	1.13	2.70	2.26	amps
Effective Load, Plate to Plate	- - - - -	6600	10,000	3300	5000	ohms
Peak A-F Grid Input Voltage (per tube)	- - - - -	240	275	285	310	volts
Max-Signal Peak Driving Power	- - - - -	42	40	134	118	watts
Max.-Signal Nominal Driving Power (approx.)	- - - - -	21	20	67	59	watts
Max.-Signal Plate Power Output	- - - - -	3700	4000	7400	8000	watts
Will Modulate R. F. Final Input of	- - - - -	6670	7250	13,340	14,500	watts

*Adjust to give stated zero-signal plate current.

APPLICATION

► **Cooling**—A minimum air flow of 120 cubic feet per minute must be passed through the anode cooler. The pressure drop across the cooler at this rate of flow equals 1.0 inch of water when the tube is cold, and increases with rising temperature to 1.25 inches when the plate dissipation attains its rated maximum value of 2500 watts.

A minimum air flow of 6 cubic feet per minute must also be directed into the filament stem structure between the inner and outer filament terminals. Cooling air in the above quantities must be supplied to the anode cooler and the filament seals before filament voltage is applied, and the air flow should be maintained for at least one minute after the filament power has been removed. Simultaneous removal of all power and air (as in case of power failure) will not ordinarily injure the tube, but it is not recommended as a standard operating practice. Anode-cooler-core, grid- and filament-seal temperatures must not exceed 150° C.

The figures above are for an ambient temperature of 20° C at sea level and do not include duct or filter losses. Further information regarding operation at higher ambient temperatures or higher altitudes is available in an article entitled "Blower Selection for Forced Air Cooled Tubes", by A. G. Nekut, in the August, 1950, issue of "Electronics".

► **Filament Voltage**—The filament voltage, as measured directly at the tube, should be 7.5 volts with maximum allowable variations due to line fluctuation of from 7.12 to 7.87 volts.

► **Bias Voltage**—There is little advantage in using bias voltages in excess of those given under "Typical Operation", except in certain very specialized applications. Where bias is obtained from a grid resistor, suitable protective means must be provided to prevent excessive plate dissipation in the event of loss of excitation.

► Indicates change from sheet dated 2-15-50.

► **Plate Voltage**—The plate-supply voltage for the 3X2500A3 should not exceed 6000 volts. In most cases there is little advantage in using plate-supply voltages higher than those given under "Typical Operation" for the power output desired.

In Class-C FM or Telegraphy service, a 0.1 henry choke, shunted by a spark gap, should be series connected between the plates of the amplifier tubes and the high-voltage-plate-supply capacitor to offer protection from transients and surges. In plate-modulated service, where a plate-modulation transformer is used, the protective choke is not normally required.

► **Grid Dissipation**—The power dissipated by the grid of the 3X2500A3 must never exceed 150 watts. Grid dissipation may be calculated from the following expression:

$$P_g = e_{cmp} I_c$$

where P_g = Grid dissipation,
 e_{cmp} = Peak positive grid voltage, and
 I_c = D-c grid current.

e_{cmp} may be measured by means of a suitable peak voltmeter connected between filament and grid. Any suitable peak v.t.v.m. circuit may be used (one is shown in "Vacuum Tube Ratings", Eimac News, January 1945. This article is available, in reprint form on request).

In equipment in which the plate loading varies widely, such as oscillators used for radio-frequency heating, care should be taken to make certain that the grid dissipation does not exceed the maximum rating under any condition of loading.

In VHF operation, particularly above 75 Mc., the d-c grid current must not exceed 200 ma. under any conditions of plate loading. With lightly loaded conditions the grid driving power should be reduced so that the grid current does not exceed one-tenth of the plate current.

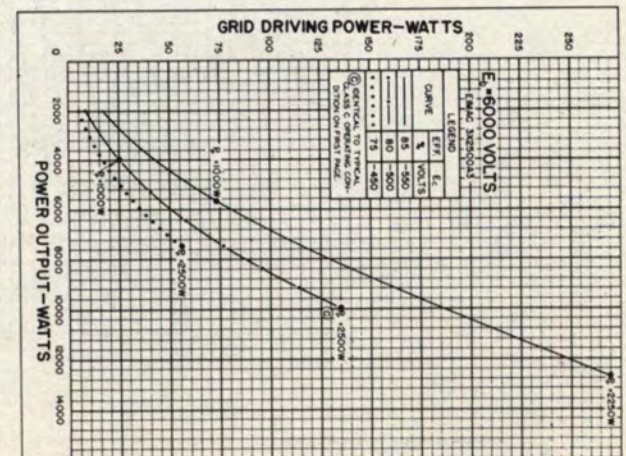
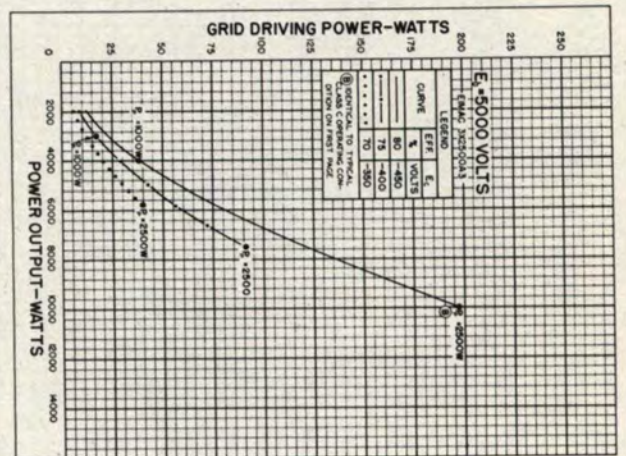
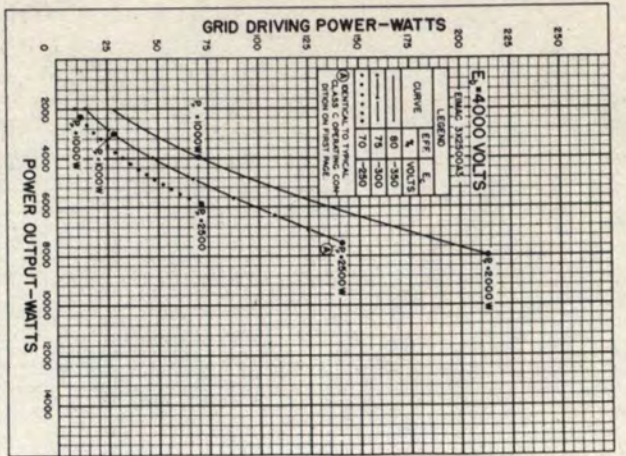

DRIVING POWER VS. POWER OUTPUT

The three charts on this page show the relationship of plate efficiency, power output and approximate grid driving power at plate voltages of 4000, 5000 and 6000 volts. These charts show combined grid and bias losses only. The driving-power and power-output figures do not include circuit losses. The plate dissipation in watts is indicated by Pp. Points A, B, and C are identical to the typical Class C operating conditions shown on the first page under 4000, 5000 and 6000 volts respectively.

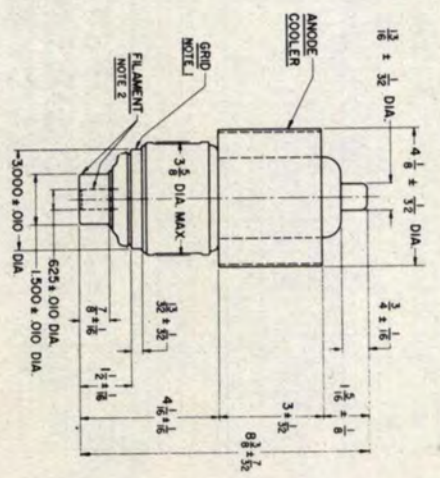
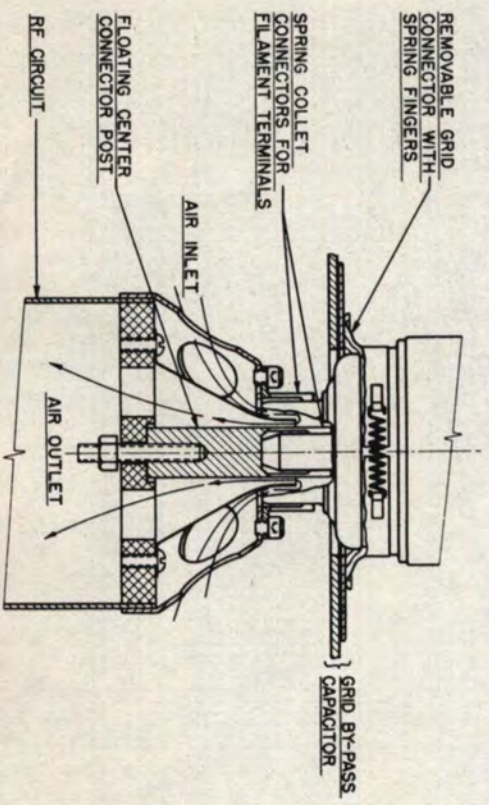

NOTE 1
 G207 MAXIMUM RADIUS OF G207 CONTACT SURFACE DETERMINED BY ANODE AND OUTER FILAMENT CONTACT SURFACE.

NOTE 2
 G207 MAXIMUM RADIUS OF INNER FILAMENT CONTACT SURFACE WITH RESPECT TO OUTER FILAMENT CONTACT SURFACE.

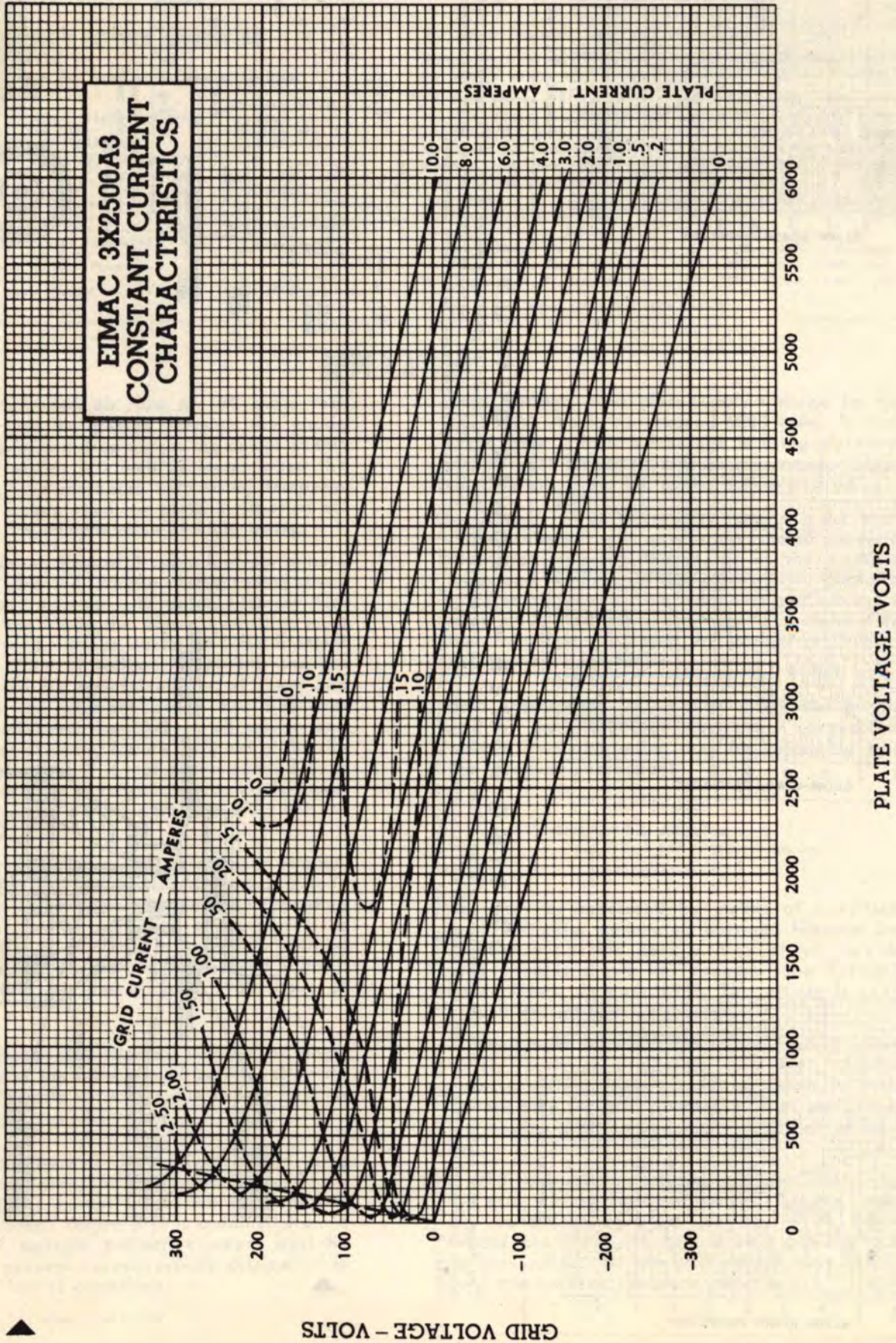

Indicates change from sheet dated 2-15-50.

The Eimac 3X2500F3 is a medium-mu, forced-air cooled, external-anode power triode intended for amplifier, oscillator and modulator service. It has a maximum plate dissipation rating of 2500 watts and is capable of high output at relatively low plate voltages. A single 3X2500F3 will deliver a radio frequency plate power-output of 7500 watts at a plate voltage of 4000 volts.

The tube is equipped with flexible filament and grid leads which simplifies socketing and equipment design for industrial and communication frequencies below 30 Mc.

The approved Federal Communications Commission rating for the 3X2500F3 as a plate modulated amplifier is 5000 watts of carrier power.



GENERAL CHARACTERISTICS

ELECTRICAL

Filament: Thoriated tungsten	
Voltage	7.5 volts
Current	51 amperes
Amplification Factor (Average)	20
Direct Interelectrode Capacitances (Average)	
Grid-Plate	20 μmfd
Grid-Filament	36 μmfd
Plate-Filament	1.2 μmfd
Transconductance ($i_b = 830 \text{ ma.}, E_b = 3000 \text{ v.}$)	20,000 μmhos
Frequency for Maximum Ratings	30 Mc

MECHANICAL

Base	See Drawing
Mounting	Vertical, base down or up
Maximum Overall Dimensions:	
Length (does not include filament connectors)	9.0 inches
Diameter	4.156 inches
Net weight	7.5 pounds
Shipping weight (Average)	17 pounds

► Cooling

A minimum flow of 120 cubic feet of air per minute must be passed through the anode cooler. The pressure drop across the cooler at this flow equals 1.0 inch of water. A minimum air-flow of 6 cubic feet per minute must also be directed toward the filament-stem structure, between the inner and outer filament conductors. Cooling air in the above quantities must be supplied to both anode cooler and filament seals before applying filament voltage and should be continued for one minute after the filament power is removed. Anode-cooler core, grid and filament seal temperatures must not exceed 150° C. These figures are for an ambient temperature of 20° C at sea level and do not include duct or filter losses.

RADIO-FREQUENCY POWER AMPLIFIER OR OSCILLATOR

► (Conventional Neutralized Amplifier—Frequencies below 30 Mc.)
Class-C FM or Telegraphy (Key-down conditions, per tube)

MAXIMUM RATINGS	
D-C PLATE VOLTAGE	6000 MAX. VOLTS
D-C PLATE CURRENT	2.5 MAX. AMPS
PLATE DISSIPATION	2500 MAX. WATTS
PLATE COOLER CORE TEMPERATURE	150 MAX. ° C
GRID DISSIPATION*	150 MAX. WATTS

* SEE APPLICATION NOTES.

TYPICAL OPERATION (Frequencies below 30 Mc. per tube)

D-C Plate Voltage	4000	5000	6000	volts
D-C Plate Current	2.5	2.5	2.08	amps
D-C Grid Voltage	-300	-450	-500	volts
D-C Grid Current	245	265	180	ma
Peak R-F Grid Input Voltage	580	750	765	volts
Driving Power (approx.)	142	197	136	watts
Grid Dissipation	68	78	46	watts
Plate Power Input	10,000	12,500	12,500	watts
Plate Dissipation	2500	2500	2500	watts
Plate Power Output	7500	10,000	10,000	watts

PLATE-MODULATED RADIO-FREQUENCY AMPLIFIER

► (Conventional Neutralized Amplifier—Frequencies below 30 Mc.)
Class-C Telephony (Carrier conditions, per tube)

MAXIMUM RATINGS	
D-C PLATE VOLTAGE	5000 MAX. VOLTS
D-C PLATE CURRENT	2.0 MAX. AMPS
PLATE DISSIPATION	1670 MAX. WATTS
PLATE COOLER CORE TEMPERATURE	150 MAX. ° C
GRID DISSIPATION	150 MAX. WATTS

TYPICAL OPERATIONS (Frequencies below 30 Mc. per tube)

D-C Plate Voltage	4000	4500	5000	volts
D-C Plate Current	1.67	1.55	1.45	amps
Total Bias Voltage	-450	-500	-550	volts
Fixed Bias Voltage	-230	-325	-410	volts
Grid Resistor	1500	1500	1400	ohms
D-C Grid Current	150	120	100	ma
Peak R-F Grid Input Voltage	680	720	760	volts
Driving Power (approx.)	102	86	76	watts
Grid Dissipation	35	26	21	watts
Plate Power Input	6670	6970	7250	watts
Plate Dissipation	1670	1670	1670	watts
Plate Power Output	5000	5300	5580	watts

IF IT IS DESIRED TO OPERATE THIS TUBE UNDER CONDITIONS WIDELY DIFFERENT FROM THOSE GIVEN UNDER "TYPICAL OPERATION," POSSIBLY EXCEEDING THE MAXIMUM RATINGS GIVEN FOR CW SERVICE, WRITE EITEL-McCULLOUGH, INC., FOR INFORMATION AND RECOMMENDATIONS.

AUDIO-FREQUENCY POWER AMPLIFIER AND MODULATOR

Class B (Sinusoidal wave, two tubes unless otherwise specified)

MAXIMUM RATINGS	
D-C PLATE VOLTAGE	6000 MAX. VOLTS
MAX.-SIGNAL D-C PLATE CURRENT, PER TUBE	2.5 MAX. AMPS
PLATE DISSIPATION, PER TUBE	2500 MAX. WATTS
PLATE COOLER CORE TEMPERATURE	150 MAX. °C

TYPICAL OPERATION CLASS AB₂ (Two tubes)

D-C Plate Voltage	4000	5000	6000	volts
D-C Grid Voltage (approx.)*	-150	-190	-240	volts
Zero-Signal D-C Plate Current	0.6	0.5	0.4	amps
Max.-Signal D-C Plate Current	4.0	3.2	3.0	amps
Effective Load, Plate to Plate	2200	3600	4650	ohms
Peak A-F Grid Input Voltage (per tube)	340	360	390	volts
Max.-Signal Peak Driving Power	340	230	225	watts
Max.-Signal Nominal Driving Power (approx.)	170	115	113	watts
Max.-Signal Plate Power Output	11,000	11,000	13,000	watts

TYPICAL OPERATION CLASS AB₂ (Two tubes)

(Modulator service for 4000 and 5000 volt operation, to modulate one or two tubes, as shown under "Plate Modulated Radio Frequency Amplifier.")

D-C Plate Voltage	4000	5000	4000	5000	volts
D-C Grid Voltage (approx.)*	-155	-200	-145	-190	volts
Zero-Signal D-C Plate Current	0.4	0.4	0.6	0.5	amps
Max.-Signal D-C Plate Current	1.35	1.13	2.70	2.26	amps
Effective Load, Plate to Plate	6600	10,000	3300	5000	ohms
Peak A-F Grid Input Voltage (per tube)	240	275	285	310	volts
Max.-Signal Peak Driving Power	42	40	134	118	watts
Max.-Signal Nominal Driving Power (approx.)	21	20	67	59	watts
Max.-Signal Plate Power Output	3700	4000	7400	8000	watts
Will Modulate R. F. Final Input of	6670	7250	13,340	14,500	watts

*Adjust to give stated zero-signal plate current.

APPLICATION

Filament Voltage—The filament voltage, as measured directly at the tube, should be 7.5 volts with maximum allowable variations due to line fluctuation of from 7.12 to 7.87 volts.

Bias Voltage—There is little advantage in using bias voltages in excess of those given under "Typical Operation," except in certain very specialized applications. Where bias is obtained from a grid resistor, suitable protective means must be provided to prevent excessive plate dissipation in the event of loss of excitation.

Plate Voltage—The plate-supply voltage for the 3X2500F3 should not exceed 6000 volts. In most cases there is little advantage in using plate-supply voltages higher than those given under "Typical Operation" for the power output desired.

In Class-C FM or Telegraphy service, a 0.1 henry choke, shunted by a spark gap, should be series connected between the plates of the amplifier tubes and the high-voltage-plate-supply capacitor to offer protection from transients and surges. In plate-modulated service, where a plate-modulation transformer is used, the protective choke is not normally required.

Grid Dissipation—The power dissipated by the grid of the 3X2500F3 must never exceed 150 watts. Grid dissipation may be calculated from the following expression:

$$P_g = e_{cmp} I_c$$

where P_g = grid dissipation,
 e_{cmp} = peak positive grid voltage, and
 I_c = d-c grid current.

e_{cmp} may be measured by means of a suitable peak voltmeter connected between filament and grid. Any suitable peak v.t.v.m. circuit may be used (one is shown in "Vacuum Tube Ratings," Eimac News, January 1945. This article is available, in reprint form on request).

In equipment in which the plate loading varies widely, such as oscillators used for radio-frequency heating, care should be taken to make certain that the grid dissipation does not exceed the maximum rating under any condition of loading.

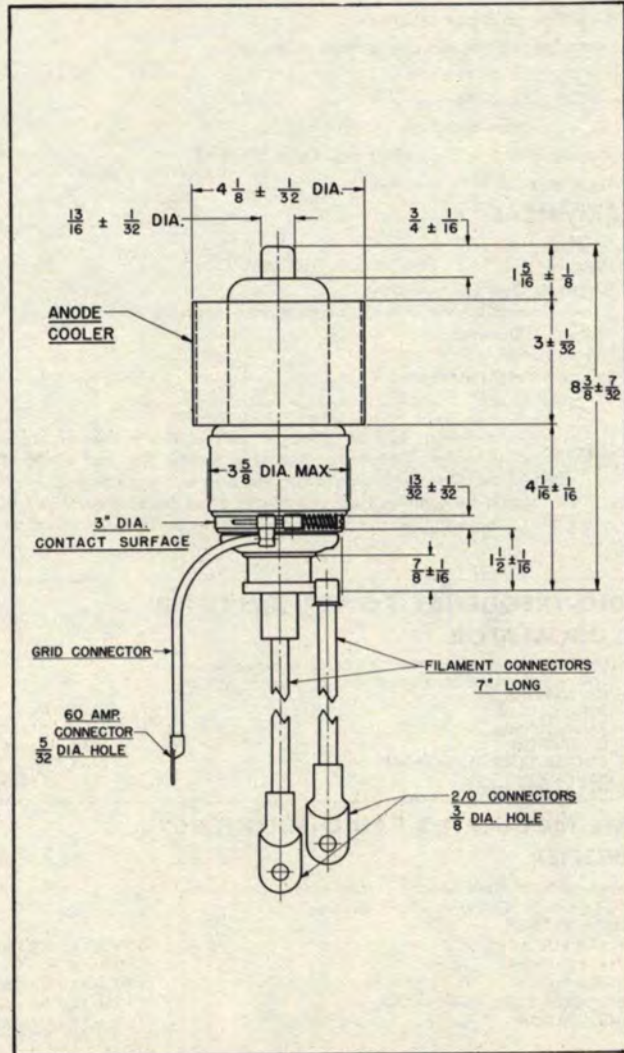

DRIVING POWER vs. POWER OUTPUT

The three charts on this page show the relationship of plate efficiency, power output and grid driving-power at plate voltages of 4000, 5000 and 6000 volts. These charts show combined grid and bias losses only. The driving power and power output figures do not include circuit losses. The plate dissipation in watts is indicated by P_p .

Points A, B, and C are identical to the typical Class C operating conditions shown on the first page under 4000, 5000 and 6000 volts respectively.

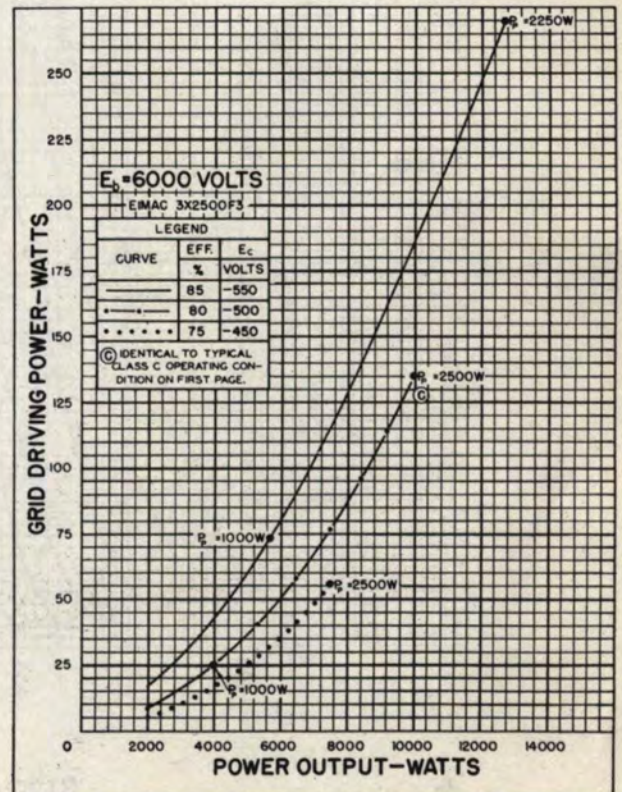
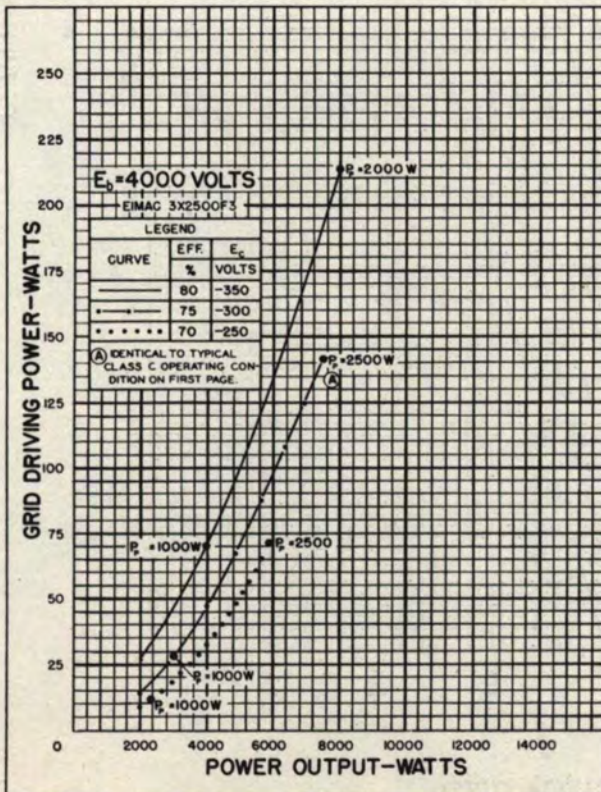
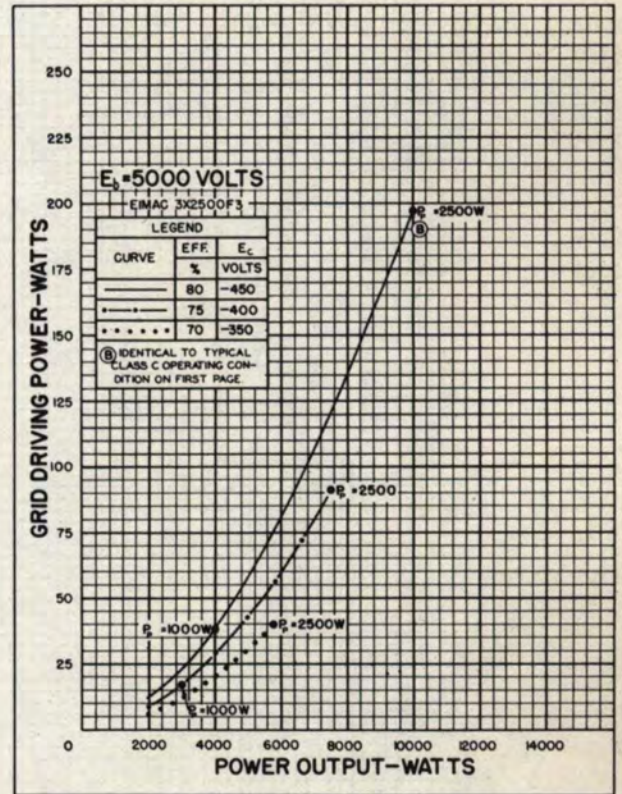

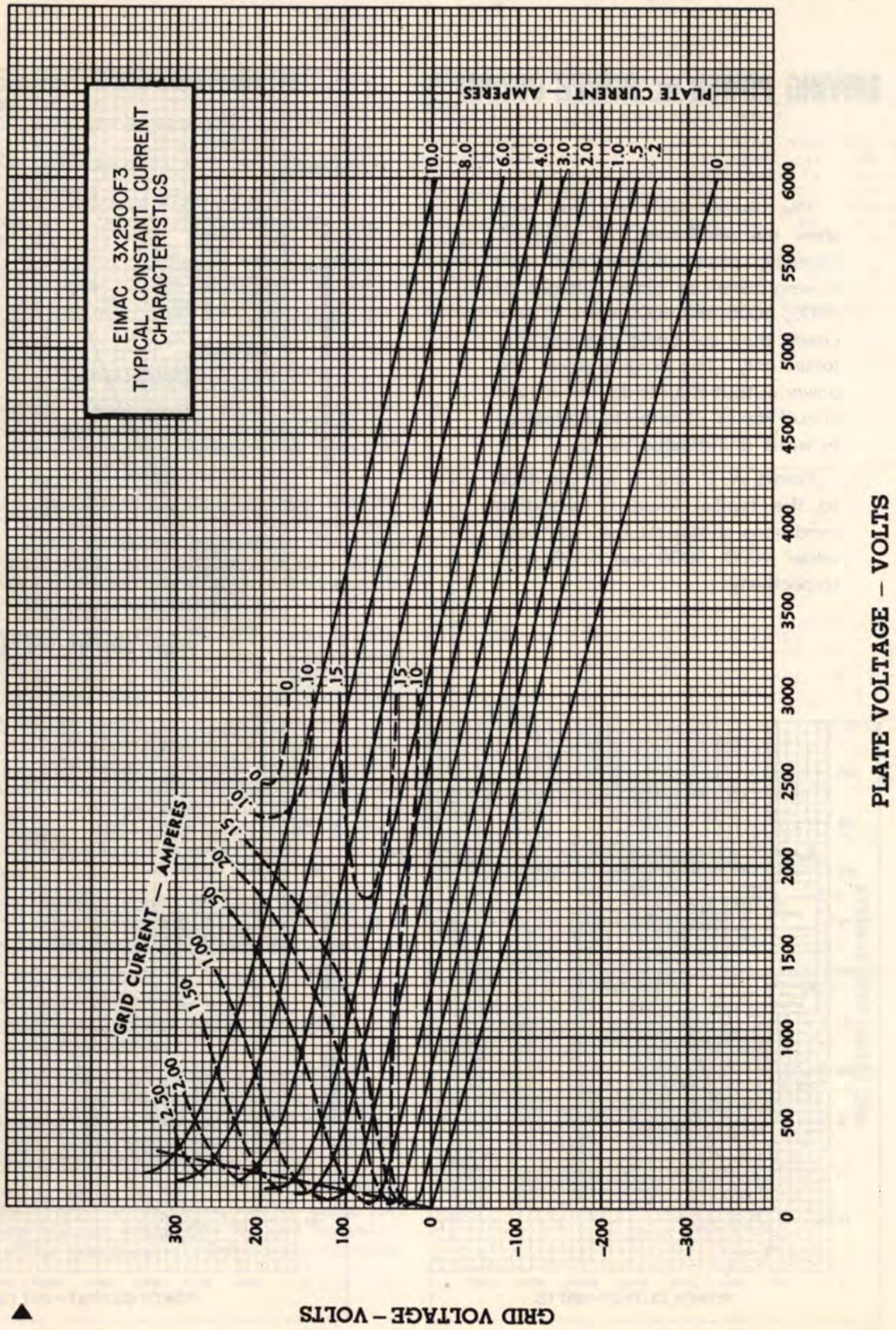

▶ Indicates Change from Sheet Dated 2-1-50

Eimac
EITEL-McCULLOUGH, INC.
 SAN BRUNO, CALIFORNIA

3X3000A1
 LOW-MU TRIODE
 MODULATOR
 AMPLIFIER

The Eimac 3X3000A1 is a low-mu forced-air-cooled power triode intended for use as an audio amplifier or modulator. The maximum rated plate dissipation is 3000 watts.

Two 3X3000A1's in class-AB₁ audio service will deliver up to 10 kilowatts maximum-signal plate power output at 6000 plate volts without drawing grid current.

GENERAL CHARACTERISTICS

ELECTRICAL

Filament: Thoriated Tungsten	
Voltage	7.5 volts
Current	51 amperes
Amplification Factor (Average)	5
Direct Interelectrode Capacitances (Average)	
Grid-Plate	17 $\mu\mu\text{f}$
Grid-Filament	29 $\mu\mu\text{f}$
Plate-Filament	2.5 $\mu\mu\text{f}$
Transconductance ($I_b = 1.0 \text{ amp.}, E_b = 3000\text{v.}$)	11,000 μmhos

MECHANICAL

Base	See outline drawing
Mounting Position	Vertical, base down or up
Cooling	Forced air
Maximum Temperatures:	
Grid and Filament Seals, Anode Cooler Core	150°C
Maximum Overall Dimensions:	
Length	9.0 inches
Diameter	4.16 inches
Net Weight	6.25 pounds
Shipping Weight (Average)	16 pounds



AUDIO FREQUENCY POWER AMPLIFIER OR MODULATOR

Class-AB₁

MAXIMUM RATINGS (Per tube)

D-C PLATE VOLTAGE	6000 MAX. VOLTS
D-C PLATE CURRENT	2.5 MAX. AMPERES
PLATE DISSIPATION	3000 MAX. WATTS
GRID DISSIPATION	50 MAX. WATTS

TYPICAL OPERATION (Sinusoidal wave, two tubes unless otherwise specified)				
D-C Plate Voltage	3000	4000	5000	6000 volts
D-C Grid Voltage (approx.) ¹	-600	-860	-1080	-1300 volts
Zero-Signal D-C Plate Current	665	500	400	335 ma
Max-Signal D-C Plate Current	3.35	3.00	2.80	2.65 amps
Effective Load, Plate-to-Plate	1170	2160	3320	4560 ohms
Peak A-F Grid Input Voltage (per tube)	555	760	995	1250 volts
Max-Signal Driving Power (approx.)	0	0	0	0 watts
Max-Signal Plate Power Input	10,000	12,000	14,000	16,000 watts
Max-Signal Plate Dissipation (per tube)	3000	3000	3000	3000 watts
Max-Signal Plate Power Output	4000	6000	8000	10,000 watts
Total Harmonic Distortion ²	2.7	1.8	2.6	2.1 per cent

¹Adjust to stated Zero-Signal D-C Plate Current. Effective grid-circuit resistance must not exceed 200,000 ohms.
²At maximum signal without negative feedback.

APPLICATION

Filament Voltage—The filament voltage, as measured directly at the tube, should be the rated value of 7.5 volts. Variations should be held within the range of 7.12 to 7.87 volts.

Cooling—The 3X3000A1 requires an air-flow of 150 cubic feet per minute through the anode cooler. This corresponds to a pressure drop across the cooler of 2.2 inches of water. A flow of 6 cubic feet per minute must also be directed into the filament stem structure, between the inner and outer filament conductors.

The air-flow must be started when power is applied to the filament, and must continue without interruption

until all electrode voltages have been removed from the tube. It is advisable to permit the air-cooling system to operate for two minutes or more after the removal of power.

These air requirements are based upon operation at an ambient temperature of 20°C and at sea level.

Cooling conditions for the 3X3000A1 may be considered satisfactory if the temperature of the anode cooler core and of the metal parts of the metal-to-glass seals is not allowed to exceed 150°C. A convenient accessory for the measurement of these temperatures is "Tempilaq", a temperature-sensitive lacquer manufactured by the Tempil Corporation, 132 West 22nd St., New York 11, N. Y.

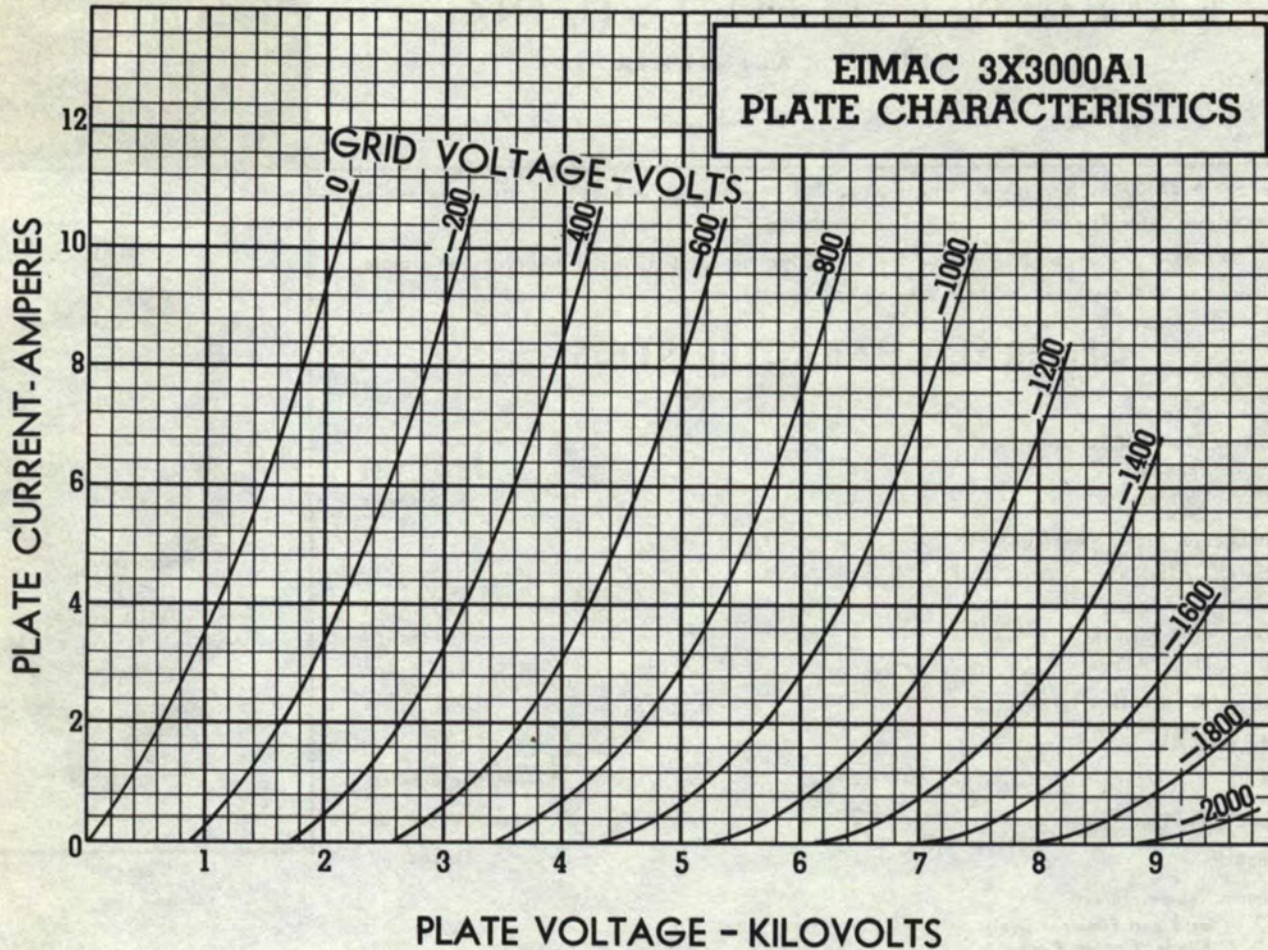

NOTE 1
.040" MAXIMUM RUNOUT OF
GRID CONTACT SURFACE
WITH RESPECT TO AXIS
DETERMINED BY ANODE
AND OUTER FILAMENT
CONTACT SURFACE.

NOTE 2
.025" MAXIMUM RUNOUT OF
INNER FILAMENT CONTACT
SURFACE WITH RESPECT TO
TO OUTER FILAMENT
CONTACT SURFACE.

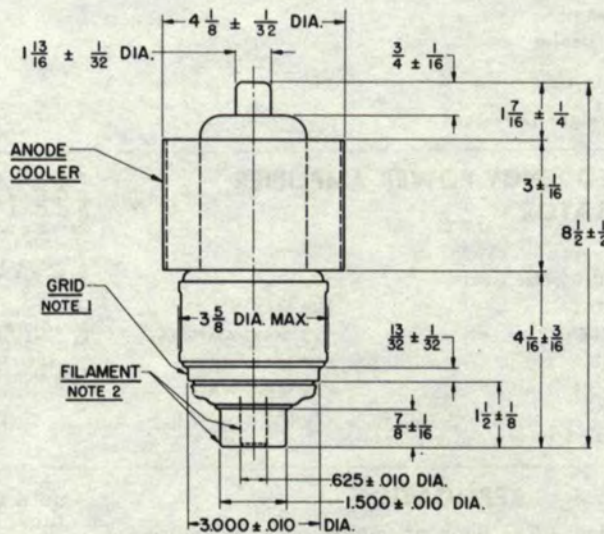

BOTTOM VIEW

**DIMENSIONS
IN INCHES**

3K20,000LK

KLYSTRON

L-BAND

AMPLIFIER

EITEL-McCULLOUGH, INC.
SAN BRUNO, CALIFORNIA

The Eimac 3K20,000LK is a three cavity, cascade, magnetically focused, power amplifier klystron intended primarily for UHF television broadcast service. A single 3K20,000LK operating as a television visual r-f amplifier will deliver 5.5 kW of peak synchronizing power output with a power gain of 20 to 25 decibels. The cavities of the Eimac UHF television klystron are completed by tuning boxes external to the tube.

NOMINAL TUNING RANGE

The entire UHF television band (470-890 Mc) is covered by three tubes of the 3K20,000L series:

TUBE TYPE NUMBER	Mc.	CHANNEL
3K20,000LA	470-580	14-32
3K20,000LF	580-720	33-55
3K20,000LK	720-890	56-83



GENERAL CHARACTERISTICS

MECHANICAL

Mounting	- - - -	Support from mounting flange
Mounting Position	- - - -	Axis Vertical
Cooling	- - - -	Water & Forced Air
Connections:		
Filament	- - - -	Flexible Leads
Cathode	- - - -	Cylindrical Strap
Focus Electrode	- - - -	Cylindrical Strap
Cavities	- - - -	Multiple Contact Fingers
Maximum Overall Dimensions:		
Length	- - - -	38 Inches
Diameter	- - - -	5-11/16 Inches
Net Weight	- - - -	45 Pounds
Shipping Weight (Average)	- - - -	205 Pounds

ELECTRICAL

Filament: Pure Tungsten		
Voltage	- - - -	9.0 Volts
Current (with cathode cold)	- - - -	42. Amperes
Current (with cathode at operating temperature)	- - - -	39. Amperes
Maximum Allowable Starting Current	- - - -	84. Amperes
Cathode: Unipotential; heated by electron bombardment		
MAXIMUM CATHODE RATINGS		
DC Voltage	- - - -	2300. Maximum Volts
DC Current	- - - -	.75 Maximum Amperes
DC Power	- - - -	1600. Maximum Watts
Focus Electrode:		
*Voltage (with respect to cathode)	- - - -	0 Volts
Magnetic Field: Axial		
Field Strength (approximately)	- - - -	120. Gauss
Nominal Frequency Range	- - - -	720-890 Mc
TV Channels	- - - -	56-83

*May be varied over a range of 0 to -500 volts if beam current control is desired.

**ULTRA HIGH FREQUENCY POWER AMPLIFIER
MAXIMUM RATINGS**

DC BEAM VOLTAGE	- - - -	14.0 Max. kV
DC BEAM CURRENT	- - - -	1.7 Max. Amps
COLLECTOR DISSIPATION	- - - -	20.0 Max. kW

Note: Maximum beam voltage and beam current should not be applied without modulation (r-f drive).

TYPICAL OPERATION

RF Linear Amplifier—Television Visual Service (In accordance with 1953 United States Federal Communications Commission Standards)

DC Cathode Bombarding Voltage	-	2100	Volts
DC Cathode Bombarding Current	-	.66	Amperes
DC Cathode Bombarding Power	-	1400	Watts
DC Beam Voltage	-	13.3	kV
DC Beam Current	-	1.55	Amperes
†DC Collector Current (approximately)-	-	1.25	Amperes
Peak Synchronizing Level			
*Driving Power (approximately)	-	55.	Watts
Power Output	-	5.5	kW
Efficiency	-	27.	Percent
Black Level			
†Collector Dissipation (approximately)	-	14.	kW
*Driving Power (approximately)	-	36.	Watts
Power Output	-	3.3	kW
Efficiency	-	16.	Percent

RF Amplifier—Television Aural Service

DC Cathode Bombarding Voltage	-	2100	Volts
DC Cathode Bombarding Current	-	.66	Amperes
DC Cathode Bombarding Power	-	1400.	Watts
DC Beam Voltage	-	10.5	kV
DC Beam Current	-	1.1	Amperes
†DC Collector Current	-	.9	Amperes
Driving Power	-	10.	Watts
†Collector Dissipation (approximately)	-	7.	kW
Power Output	-	2.75	kW
Efficiency	-	24.	Percent

†May vary somewhat from tube to tube.

*Total driving power including losses inserted for broadband operation.

Typical operation figures were obtained by direct measurement in operating equipment. The output power is useful power measured in a load circuit. The driving power is the total power taken by the tube and a practical resonant circuit. In many cases with further refinement and improved techniques better performance might be had. For the present the figures can be taken as attainable values.

APPLICATION

Mounting—The 3K20,000LK is provided with two integral mounting flanges, located as shown on the outline drawing. Either flange may be used to support the tube. Two threaded holes are provided in the Input Pole Piece and are shown on the outline drawing. When fitted with eye bolts, the tube may be hung from these bolts during mounting operations. The eye bolts must be removed after mounting operations are completed to prevent high voltage arc-over.

Filament Operation—For maximum tube life, the pure tungsten filament should be operated just above the emission limiting temperature. This temperature will be obtained with a filament voltage, as measured directly at the terminals, of approximately 9 volts. The filament voltmeter should be capable of indicating within 1% accuracy and unavoidable voltage variation should be within the range of $\pm 2\%$. If a voltage regulator is used, the voltmeter should be a moving iron vane or dynamometer type capable of reading correct RMS voltage with distorted wave form.

Cathode Heating Power — The cathode of the 3K20,000LK is unipotential and heated by electron bombardment. A dc potential of approximately 2100 volts is applied between the filament and the cathode; and the recommended cathode heating power of 1400 watts is obtained with approximately .66 amperes. The filament is designed to operate under space-charge limited conditions so that cathode temperature may be varied by changing the voltage between the filament and the cathode.

Cooling—Air and water flow must be started before the filament and cathode power are applied and maintained for at least two minutes after the filament and cathode power have been removed. Tube temperatures may be measured with a temperature-sensitive paint, such as "Tempilaq", manufactured by the Tempil Corporation, 132 West 22nd Street, New York 11, N. Y.

3K20,000LK Cooling Requirements for Typical Operating Conditions and Correct Magnetic Field Adjustment:

	Cooling Medium	Volume	Pressure Drop	Remarks
Input Pole Piece	Water	1 gpm	8 psi	Total Pressure Drop if Series Connected with 5/16" tubing = 24. psi
Short Drift Tube Jacket	*Water	1 gpm	2 psi	
Long Drift Tube Jacket	*Water	1 gpm	2 psi	
Output Pole Piece	Water	1 gpm	1.6 psi	
Collector Assembly	Water	6 gpm	3 psi	
Electron Gun Structure	Filament Stem	Air	1-2 cfm	See Cooling Diagram
	Cathode Terminal	Air	90 cfm	
	Focus Electrode Seals	Air	30 cfm	
Input Cavity	-	None		
Center Cavity	-	Air	15 cfm	
Output Cavity	-	Air	50 cfm	

*Water inlet must be at bottom and outlet at top to avoid air traps.

The inlet water pressure of the Pole Pieces and the Drift Tube Jackets should not exceed 40 pounds per square inch. The inlet water pressure of the Collector Assembly should not exceed 25 pounds per square inch. Only clean, filtered air

should be blown on the tube. The cooling water should be of sufficient purity to prevent liming of the water system. The outlet water temperature must not exceed a maximum of 70°C under any condition. The temperature of the metal-to-glass seals should not exceed 150°C.

RF Contact Surfaces—The means by which contact is made between the cavities and the tuning boxes is of great importance. Two requirements which must be met to ensure proper tube performance are as follows:

- (1) Contact to the tube cavities must be made only on the peripheral surface of the 1/4" cavity flanges as shown on the outline drawing.
- (2) Each individual finger of the collet or spring stock material must make positive contact to the cavity flange.

Magnetic Field—An adjustable magnetic field is necessary to control and direct the beam throughout the length of the drift tube. The magnetic field should be capable of variation around the recommended field strength of 120 gauss. Beam transmission (collector current divided by the beam current as measured in the cathode return to beam power supply) will vary from 75% to 95%. Improper adjustment or misalignment of the magnetic field, as indicated by too low a value of beam transmission, may cause the beam to impinge on and overheat the drift tube walls.

Caution—It is convenient to operate the r-f and collector portions of the tube at ground potential. Since the cathode and filament are operated at high negative potentials with respect to ground, filament and cathode power supplies and voltmeters must be adequately insulated for these high voltages. Protection must also be afforded to operating personnel.

Protection—It is recommended that the following protective devices be used:

- (1) Interlocks in air and water supplies.
- (2) Interlock in magnetic field supply circuit.
- (3) Current overload in cathode bombardment supply circuit.
- (4) Current overload in beam current supply circuit.
- (5) Current underload in collector current circuit.
- (6) Current limiting resistor of approximately 100 ohms in series with beam power supply to isolate tube from final capacitor of supply.

The filament and cathode bombardment voltages will normally be applied before the beam voltage. Cavity tuning or magnet adjustment should be made with reduced beam voltage (1/2 to 2/3 normal). Slight retuning and readjustment will be necessary when beam voltage is raised to full value.

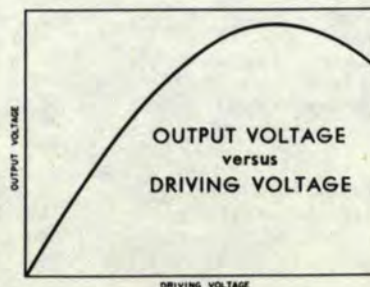

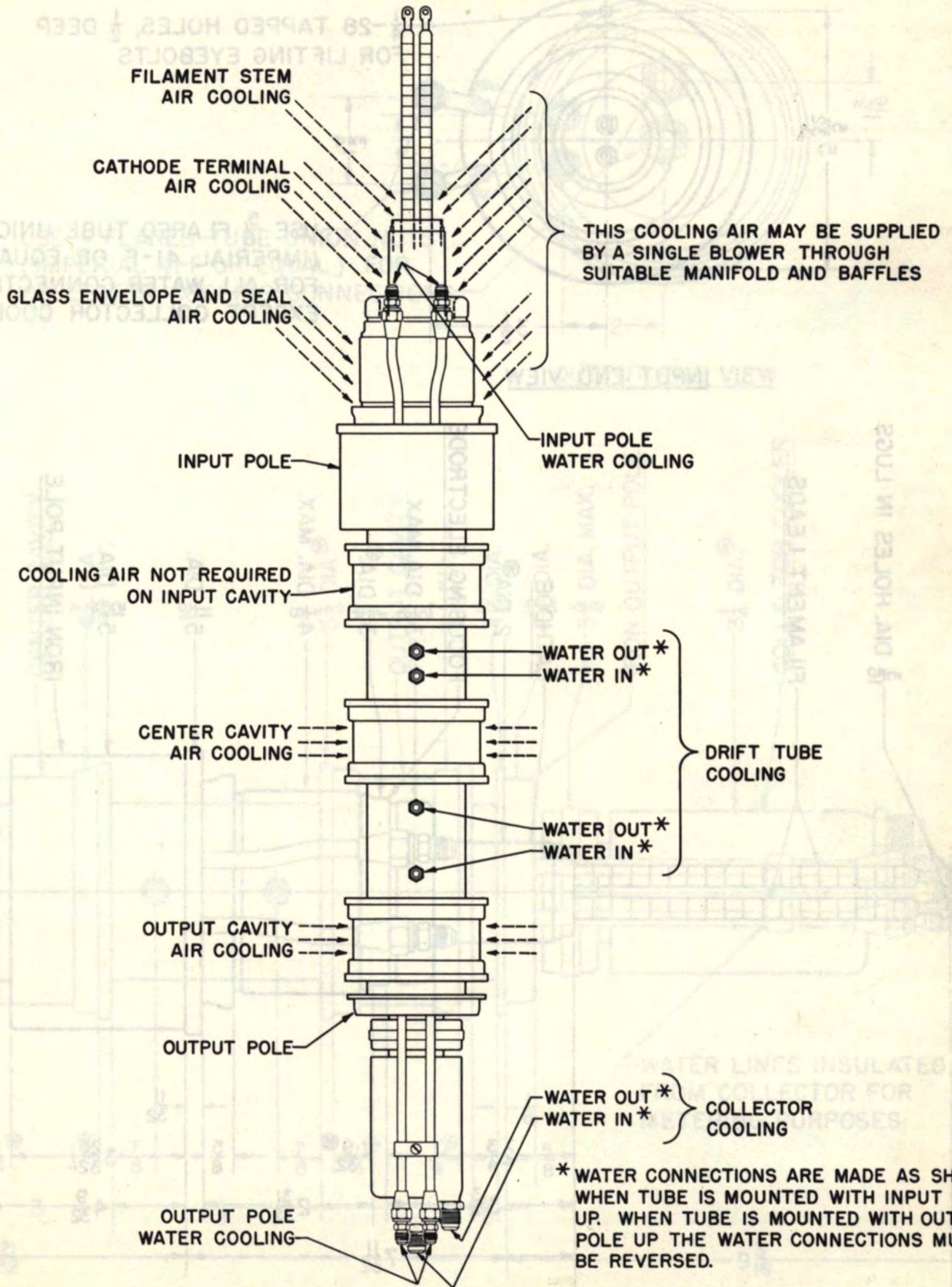

COOLING DIAGRAM

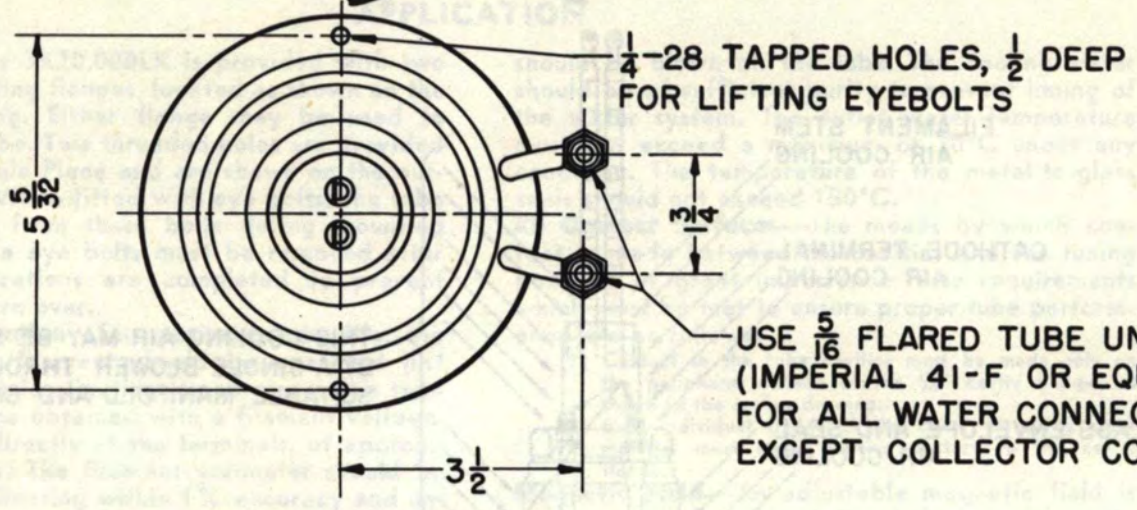

USE $\frac{5}{16}$ FLARED TUBE UNION NUTS (IMPERIAL 41-F OR EQUAL) FOR ALL WATER CONNECTIONS EXCEPT COLLECTOR COOLING

INPUT END VIEW

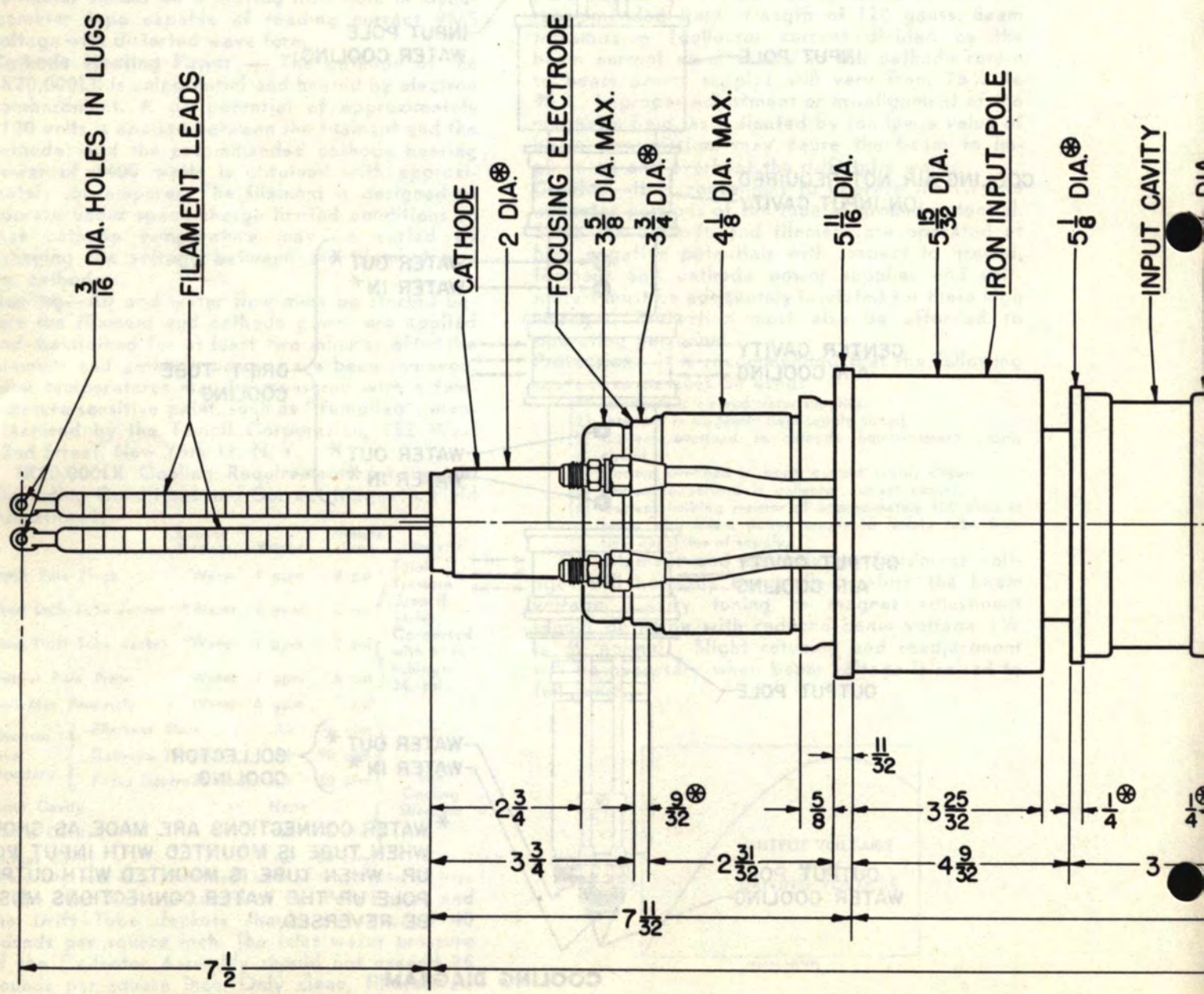

DIMENSIONS IN INCHES

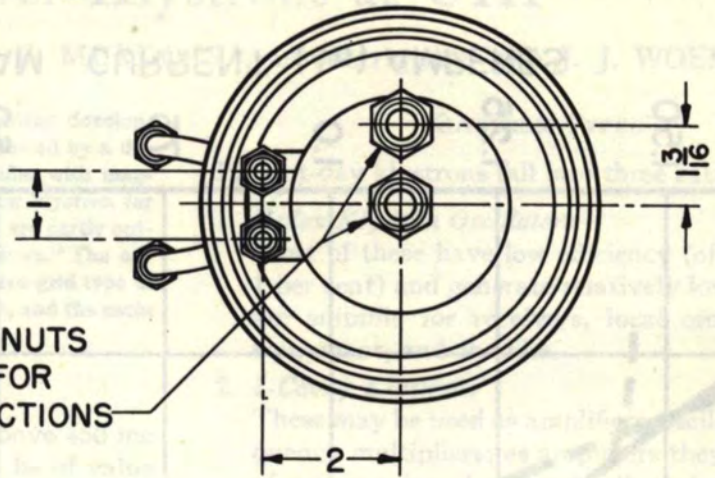

USE $\frac{1}{2}$ FLARED TUBE UNION NUTS
 (IMPERIAL 41-F OR EQUAL) FOR
 COLLECTOR COOLING CONNECTIONS

OUTPUT END VIEW

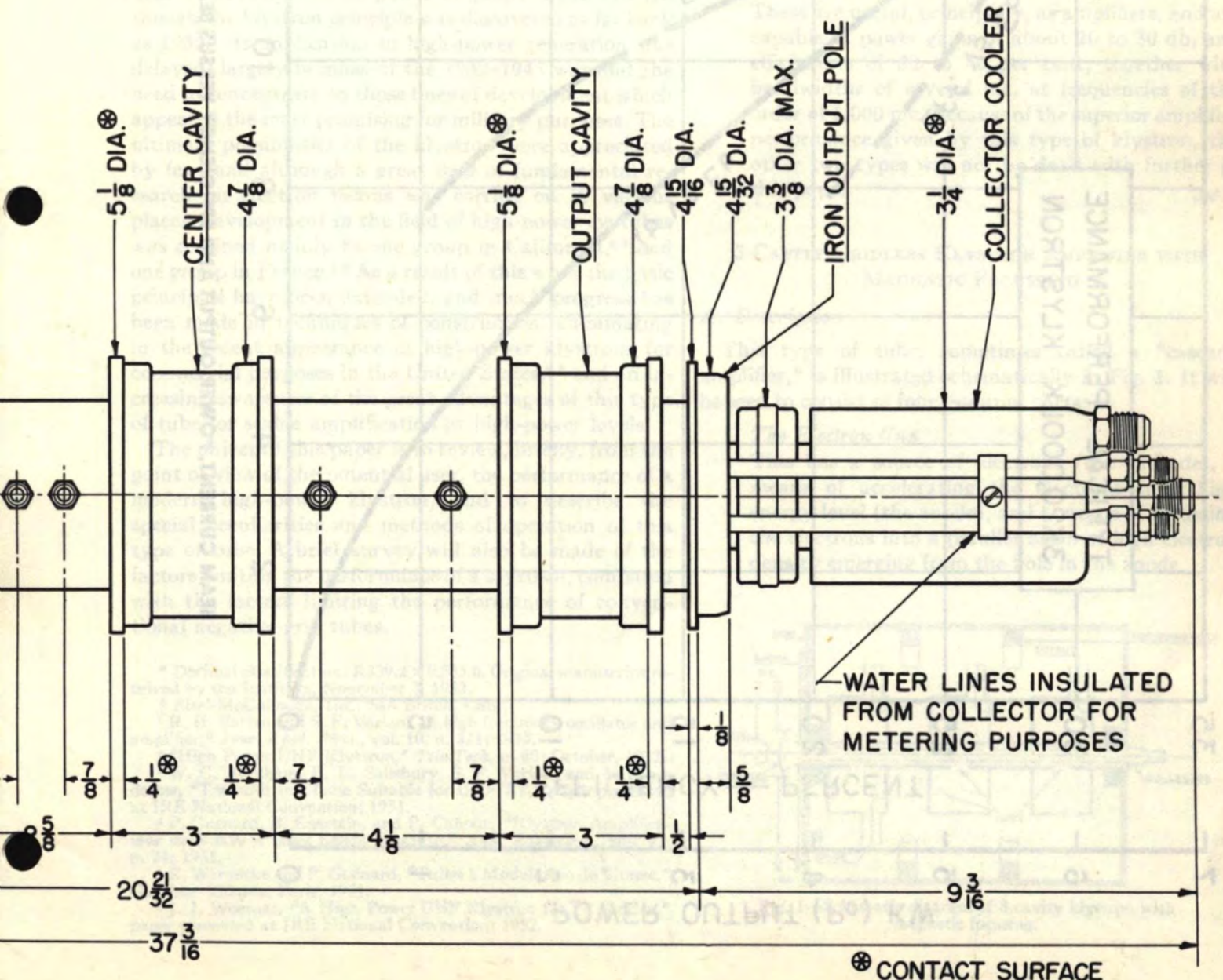

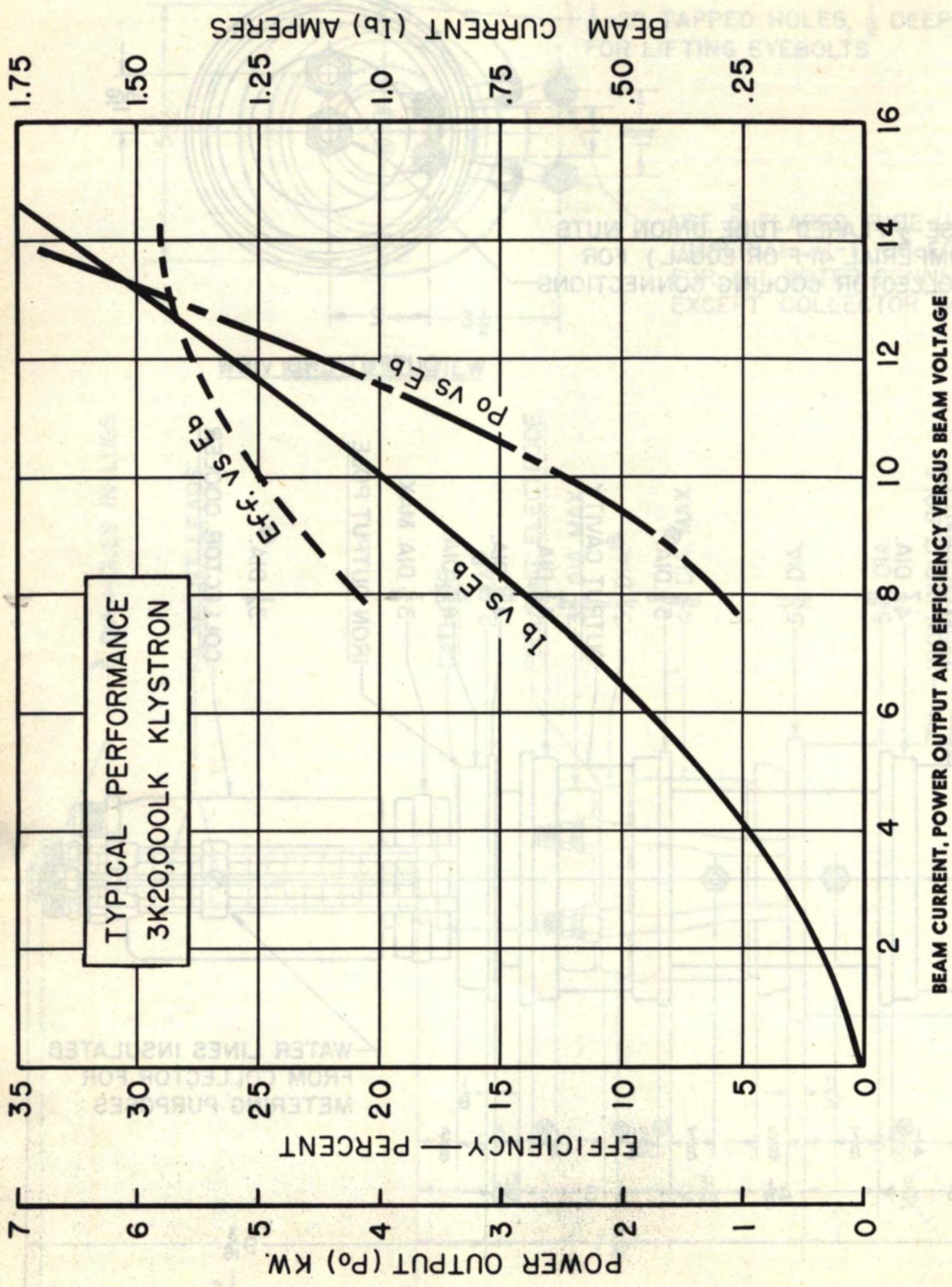

High-Power Klystrons at UHF*

D. H. PREIST†, MEMBER, IRE, C. E. MURDOCK†, ASSOCIATE, IRE, AND J. J. WOERNER†

Summary—A brief history of high-power cw klystron development and a classification of types of klystron are followed by a description of the three-cavity, gridless klystron amplifier with magnetic focusing, in general terms, and the Eimac 5-kw klystron for UHF-TV in more detail. This tube has cavities which are partly outside the vacuum system and contain ceramic "windows." The advantages of the klystron over the conventional negative-grid type of tube are reviewed from the standpoint of performance, and the main operational features are noted.

INTRODUCTION

IN VIEW OF the increasing activity above 450 mc for such purposes as television, it may be of value to review the means of generating transmitter power presently available.

Of outstanding interest in this field is the post-World War II development of power amplifier klystrons. Although the klystron principle was discovered as far back as 1939,¹ its application to high-power generation was delayed, largely because of the 1939–1945 war and the need to concentrate on those lines of development which appeared the most promising for military purposes. The ultimate possibilities of the klystron were appreciated by few, and although a great deal of fundamental research on electron beams was carried on in various places, development in the field of high-power cw tubes was confined mainly to one group in California,^{2,3} and one group in France.^{4,5} As a result of this work the basic principles have been extended, and much progress has been made in techniques of construction, culminating in the recent appearance of high-power klystrons for commercial purposes in the United States,^{2,6} and an increasing awareness of the great advantages of this type of tube for stable amplification at high-power levels.

The object of this paper is to review, briefly, from the point of view of the potential user, the performance of a modern high-power klystron, and to describe the special peculiarities and methods of operation of this type of tube. A brief survey will also be made of the factors limiting the performance of a klystron, compared with the factors limiting the performance of conventional negative-grid tubes.

* Decimal classification: R339.2×R583.6. Original manuscript received by the Institute, November 3, 1952.

† Eitel-McCullough, Inc., San Bruno, Calif.

¹ R. H. Varian and S. F. Varian, "A high frequency oscillator and amplifier," *Jour. Appl. Phys.*, vol. 10, p. 321; 1939.

² "High Power UHF Klystron," *Tele-Tech*, p. 60; October, 1952.

³ W. C. Abraham, F. L. Salisbury, S. F. Varian, and M. Chodorow, "Transmitting Tube Suitable for UHF TV," paper presented at IRE National Convention; 1951.

⁴ P. Guénard, B. Epsztein, and P. Cahour, "Klystron Amplificateur de 5 KW à large bande passante," *Ann. Radioelect.*, vol. VI, p. 24; 1951.

⁵ R. Warnecke and P. Guénard, "Tubes à Modulation de Vitesse," Gauthier-Villards, Paris; 1951.

⁶ J. J. Woerner, "A High Power UHF Klystron for TV Service," paper presented at IRE National Convention; 1952.

KLYSTRON TYPES

Present-day klystrons fall into three categories:

1. Reflex Klystron Oscillators

Most of these have low efficiency (of the order of 1 per cent) and generate relatively low power, and are suitable for receivers, local oscillators, test equipment, and the like.

2. 2-Cavity Klystrons

These may be used as amplifiers, oscillators, or frequency multipliers; as amplifiers they are capable of power gains of about 13 db and efficiencies of about 20 per cent, at frequencies of the order of 1,000 mc.

3. 3-Cavity Klystrons

These are useful, principally, as amplifiers, and are capable of power gains of about 20 to 30 db, and efficiencies of 30 to 40 per cent, together with bandwidths of several mc, at frequencies of the order of 1,000 mc. Because of the superior amplifier performance given by this type of klystron, the other two types will not be dealt with further in this paper.

3-CAVITY GRIDLESS KLYSTRON AMPLIFIER WITH MAGNETIC FOCUSING

A. Description

This type of tube, sometimes called a "cascade amplifier," is illustrated schematically in Fig. 1. It will be seen to consist of four essential parts:

1. The Electron Gun

This has a source of electrons (the cathode), a means of accelerating the electrons to a high energy level (the anode), and a means of focussing the electrons into a parallel beam of high electron density emerging from the hole in the anode.

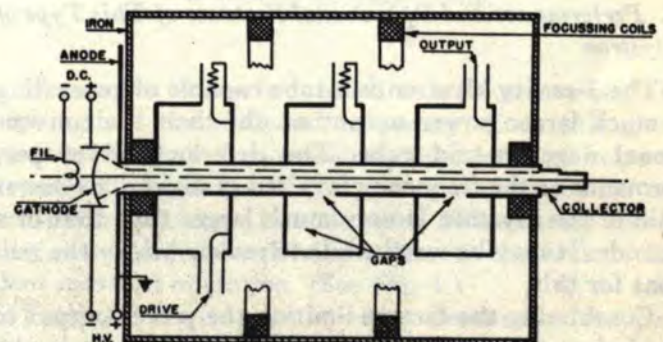

Fig. 1—Schematic diagram of 3-cavity klystron with magnetic focusing.

2. The RF Resonant Cavities and Drift Tubes

The first cavity is fed with RF energy from a driving source at low level. The second cavity is tuned to resonance, or near resonance, but is not fed with energy from outside. The function of these two cavities, in conjunction with the drift tubes, is to velocity-modulate the electron beam so as to produce "bunches" of electrons at the output cavity. The latter is tuned to resonance and coupled to the antenna, or other load, and serves to extract as much RF energy as possible from the "bunched" electron beam. Its function and operation are closely similar to those of the output circuit of a Class "C" amplifier using triodes or tetrodes.

3. The "Collector" Electrode

This collects the electrons after they have passed through the output cavity, and have given up part of their energy to the RF field, and thus to the load; because only about 30 per cent of the energy in the beam is converted to RF energy, this collector has to be capable of dissipating the remaining percentage, that is to say, 70 per cent of the product of the anode-cathode voltage and cathode current, when fully driven. (In practice the collector current is very slightly less than this because some electrons inevitably strike the anode and the drift-tube walls.) If the tube is used as a linear modulated amplifier, the collector will be required to dissipate 100 per cent of the input power under conditions of zero drive and zero output.

4. External Magnetic Circuit

This consists of suitably disposed electromagnets producing an axial magnetic field of controllable strength which tends to keep the beam parallel as it passes along the tube. Without this field the beam would expand because of the mutual repulsion of the electrons. The optimum field strength is fairly critical, and is not necessarily uniform along the length of the tube. It is usually prevented from penetrating the cathode, either by a metallic magnetic shield or by the use of a "bucking" coil, or by a combination of both.

B. Performance and Operational Features of This Type of Klystron

The 3-cavity klystron is a tube capable of generating a much larger power output at uhf than the conventional negative-grid tube. The deterioration of performance as the frequency is raised is slight. The power gain of the klystron is very much larger than that of a tetrode. It may be worthwhile to review briefly the reasons for this.

Considering the factors limiting the power output of a triode or tetrode, aside from external circuit losses, one finds that basically they are the total cathode emission, the anode voltage, the interelectrode spacing, and

the RF loss in the materials used to make the electrodes and the envelope. Now the total cathode emission, assuming the best material is used and that a given life is required, depends on its area. This area is limited at uhf because the tube forms part of a resonant transmission line in which large changes of electric and magnetic field occur over distances which are small compared with the wavelength. Since nonuniform potentials between electrodes cause loss of efficiency, it is necessary to keep the electrode dimensions small compared with the wavelength; thus, the cathode area is limited, and has to be reduced as the wavelength is decreased. The anode voltage is limited by internal flash-arcs between electrodes. The electrode spacing must, however, be small enough to give small electron transit times, and must be decreased with the wavelength. The applied voltage must, therefore, be reduced also with the wavelength. Lastly, the RF losses in the tube materials increase as the wavelength decreases. All these factors added together give the well-known result that triodes and tetrodes get rapidly smaller as the wavelength decreases, and so does the power they will generate and the efficiency. In addition, the problem of manufacture becomes more and more serious, and ultimately becomes prohibitive. The two worst problems are caused by the small spacing between electrodes, of the order of 0.001 inch, and the mechanical weakness of the fine wire grids.

Considering now the power gain, this becomes less as the wavelength decreases because the tube requires more and more driving power to overcome the increasing electron transit-time effects, losses in materials, grid current, and (usually) inherent negative feedback.

In a klystron, on the other hand, some of these limitations do not occur at all, and others are less significant. The cathode area is not limited by the wavelength because it is outside the RF field. The anode-to-cathode spacing being of the order of 1 inch, extremely high anode voltages may be applied without internal flash-arcs; also, the cavity gap spacings may be about $\frac{1}{2}$ inch in a 5-kw tube at 1,000 mc. Again, because gridless gaps may be used without serious loss of coupling between the beam and the resonant cavities, there are no problems of fabrication or heating of grid wires. Furthermore, because the collector is outside the RF field, it may be designed solely for the purpose of dissipating heat, and this becomes a minor problem in practice. The losses in the conductive tube materials are small because all the metal parts carrying RF current may be made of high-conductivity metal. (There is no loss comparable to the RF losses in a triode due to RF current flowing through lossy cathode material or fine resistive grid wires.) Therefore, the only limiting factor approached in klystrons giving adequate power for present commercial applications is the loss in the dielectrics. Some dielectrics are inevitable either in the form of windows in the cavities, as in the Eimac tube, or in the other type of tube with integral cavities, the window between the

output cavity and the load. If the power level is raised high enough, these dielectrics will ultimately break down, either by cracking due to heat or by flashing over the outside surface which is at atmospheric pressure; however, this does not occur in a well-designed tube at power levels that are presently interesting.

Considering the power gain of a klystron, this is governed almost entirely by the geometry and is limited only by the small RF losses in the input cavity and the beam loading of the cavity, which is small. The transit-time loading experienced with a triode becomes a factor of minor importance, and the negative feedback disappears since there is no coupling between the input and output cavities.

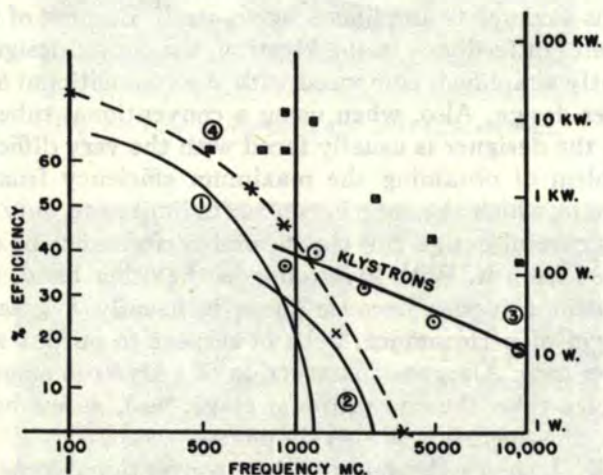

Fig. 2—Curve (1): Efficiency versus frequency for typical uhf tetrode—4X150G. (Plate dissipation 150 watts.)
Curve (2): Efficiency versus frequency for typical uhf triode—2C39. (Plate dissipation 100 watts.)
Curve (3): Typical efficiency of klystrons versus frequency (independent of output power). This is the efficiency at the optimum frequency for each tube.
Curve (4) (dotted): Maximum power output of the largest commercially available negative-grid tube at various frequencies.
Points \square cw power output of various klystrons (not the largest possible).

It is, therefore, apparent that the efficiency and power gain of a klystron will fall off relatively slowly, compared with a triode or tetrode, as the wavelength is reduced. This is illustrated by the curves in Fig. 2. It is also clear that the maximum size and power output of a klystron are not determined by the wavelength. It follows that the klystron is ideally suited to high-power generation at uhf and microwave frequencies, and out-classes the conventional type of tube in every respect, including ease of manufacture.

Turning now to a typical performance obtainable from a 3-cavity klystron, the results given by the Eimac tube may be taken as representative of this type of tube. This tube will generate 5 kw of RF power in the uhf television band with an efficiency of more than 30 per cent when fully driven. The over-all bandwidth is about 5 mc and the power gain, under television condi-

tions, is about 20 db. Salient features of operation are these:

The tuning of each of the 3 cavities is independent of the others since there is no feedback present. This makes for very simple lining-up procedure.

The output cavity is tuned to resonance at the mid-band frequency, and loaded for optimum performance by means of some variable coupling device external to the tube.

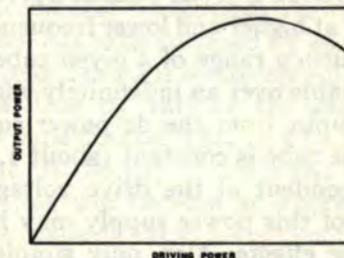

Fig. 3—Output power versus driving power for klystron.

A curve of power output against power input for this type of tube is a Bessel function of the first order and the first part of such a curve is very nearly linear. (See Fig. 3.) In television service, assuming that sync stretching is used in the driving stages, the klystron may be operated in such a way that the sync pulses drive the tube very nearly to the peak of the Bessel curve, so that the efficiency at sync pulse levels is nearly the fully driven efficiency.

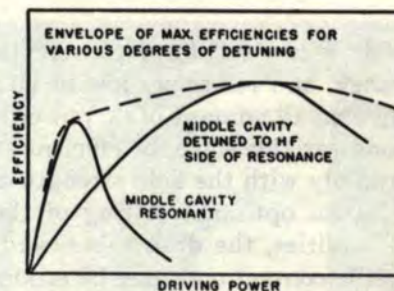

Fig. 4—Efficiency versus driving power, showing the effect of detuning the middle cavity.

The center cavity is detuned to a frequency slightly higher than the midband frequency, since this gives greater efficiency than resonant operation, and helps to broaden the pass band. This cavity may be loaded externally by resistance in some cases. This detuned operation requires greater driving power to the first cavity than resonant operation. (See Fig. 4.)

The input cavity may be either detuned on the low-frequency side of resonance or it may be tuned to resonance and loaded with external resistance in order to achieve the necessary bandwidth.

The relation between efficiency, power output, and anode voltage for a given tube is shown at Fig. 5. There is an optimum voltage for best efficiency because the voltage determines the speed of the electrons along the tube. Now a certain time is required for electron bunching to take place; this depends mainly on the frequency and determines the distance between the cavities. But this distance will be optimum for only one electron speed, and therefore only one voltage. Conversely, for a given voltage the relation between efficiency and frequency will also show a broad peak at a given frequency, and this fall-off at higher and lower frequencies will limit the useful frequency range of a given tube, even if the cavities are tunable over an indefinitely wide range.

The power input from the dc power supply feeding the anode of the tube is constant (about 1.5 amps at 13 kv), and independent of the drive voltage; therefore, the regulation of this power supply may be quite poor without adverse effects. Also, only simple circuits are necessary to reduce the hum to a low level. The filament may be heated by ac.

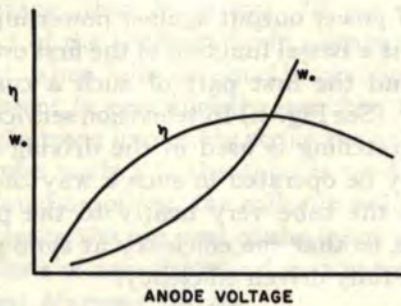

Fig. 5—Power output and efficiency versus anode voltage.

The magnetic field used for focussing the beam is simple to arrange, and relatively low in intensity, and consumes only a small amount of dc power in the coils. It must be made variable since the efficiency of the tube varies fairly rapidly with the field strength and reaches a maximum for an optimum setting of the magnetic field. The RF cavities, the drift tubes, and the anode are all in metallic contact and may be grounded. Thus,

there is no problem of by-passing and dc isolation in the output circuit compared to the by-passing problem with a triode or tetrode amplifier. The collector is usually insulated from the main part of the tube in order to facilitate monitoring of the current division between the collector and the drift tubes. The anode voltage supply is grounded on the positive side, and the negative side is connected to the cathode of the tube.

Considering now the over-all problem of design, construction, installation, and operation of a high-power uhf amplifier, and the difference between the problem with a conventional type of tube and with a klystron, it is evident that the klystron scores heavily in all respects. The burden imposed on the transmitter designer is lessened because the klystron with its cavities forms a complete amplifier stage in itself. Because of the absence of feedback in the klystron, the circuit design is greatly simplified, compared with the conventional amplifier design. Also, when using a conventional tube at uhf, the designer is usually faced with the very difficult problem of obtaining the maximum efficiency from a stage in which the tube is run to its limit, and only by very careful design can the desired performance be obtained from it. With klystrons, on the other hand, the problem is easier because there is usually a greater margin of performance, both in respect to output and power gain. Also, the construction of a klystron stage is simpler than the conventional stage, and, as we have seen, the operation is also simpler.

Fig. 1 shows the more or less conventional type of klystron construction involving integral cavities, namely, cavities which are an integral part of the vacuum system. A unique feature of the Eimac tube, hereinafter described, is that part of the cavities are external to the tube envelope so that simple mechanical tuning of the cavities over a wider band of frequencies is possible. The tube itself is also simplified.

C. A Practical Example: Eimac UHF Klystron for TV

The photograph in Fig. 6 shows the Eimac uhf klystron, an example of a 3-cavity klystron in a form suitable for commercial manufacture, and now in produc-

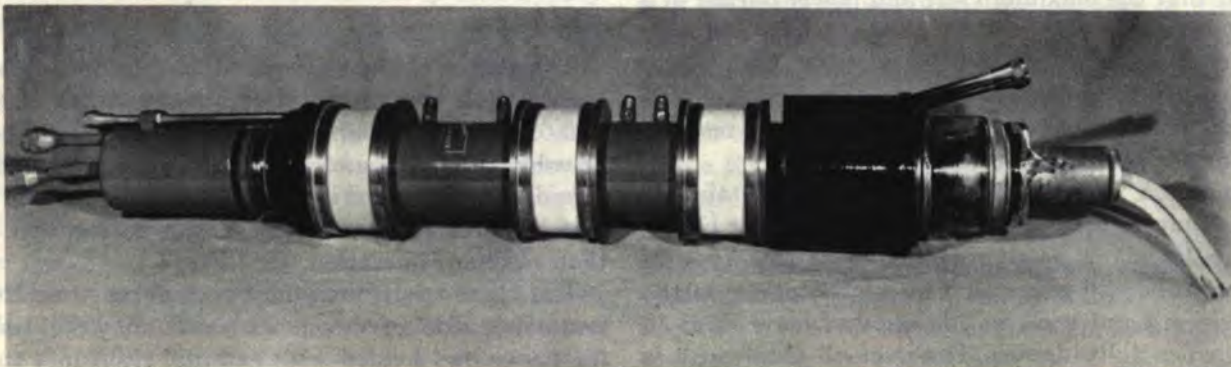

Fig. 6—The Eimac 5-kw uhf klystron for TV.

tion. Tube-cavity parts and drift-tube sections are shown in Fig. 7. Fig. 8 shows the tube and external cavities in a test setup.

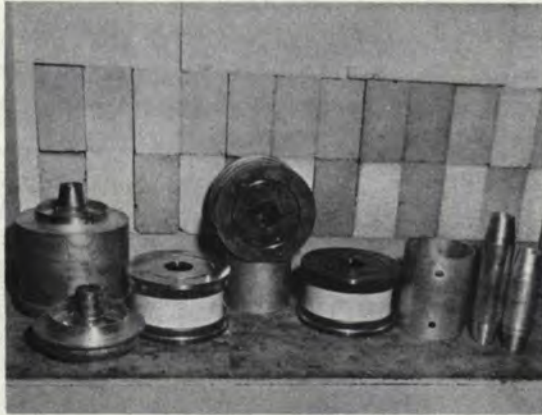

Fig. 7—Tube cavity parts and drift tube sections.



Fig. 8—The 5-kw klystron on test.

A feature of interest is the use of cavities which are tunable by means external to the vacuum system. This is made possible by use of ceramic "windows" which, if designed and fabricated correctly, will produce only a minor deterioration in the over-all performance of the tube because of their finite dielectric loss and high dielectric constant.

This means that part of each cavity is in vacuo and part is in air. The convenience of operating a tube of this type, compared with a tube in which the cavities

are entirely in vacuo, is considerable. In the first place, the mechanism for varying the resonant frequency is simple and may involve straightforward shorting bars with sliding contacts with negligible losses. These slidable devices are outside the vacuum system, as shown in Fig. 8. The tuning range of such a cavity is large. With a totally evacuated cavity it has not yet been found possible to use such a means of tuning, because sliding contacts in vacuo are generally unsatisfactory. Therefore, tuning has to be done by distortion of some flexible metallic membrane. Such a membrane introduces mechanical weaknesses into the tube structure which then has to be stiffened by an external frame. Also, the range of tuning is relatively small, and usually the tuning is done by varying the gap spacing, and therefore, its capacitance. This can be done only to a limited extent. If the gap is made too wide, the electron transit time will become an appreciable fraction of 1 RF cycle, causing inefficiency; on the other hand, if the gap is too small, the bandwidth will suffer (bandwidth varies roughly as $1/c$). With a ceramic window cavity the tuning is done by varying the inductance of the cavity, the capacitance across the gap is fixed, and the gap can be set for optimum performance over the frequency band.

Another point of difference is that the mechanical forces required to tune a cavity by means external to the vacuum system are small, being determined only by friction, whereas with the other type of cavity the tuning mechanism has to withstand the forces caused by the operation of atmospheric pressure against the flexible metallic membrane.

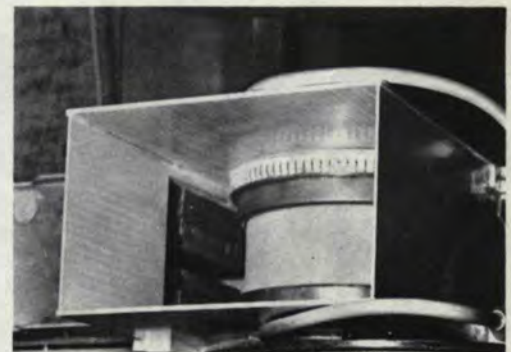

Fig. 9—Output cavity with one tuning plunger removed, showing ceramic and output coupling device.

Another desirable feature obtained with the ceramic windows is that the loading of the cavity may be accomplished outside the vacuum system, either by loops or a waveguide-to-cavity loading device, such as a quarter-wave transformer made from ridge waveguide. (See photograph of output cavity, Fig. 9.) The coupling may, therefore, be varied with ease. With a totally evacuated cavity it is very inconvenient to build in a variable load coupling, and it is common practice to use

a fixed loop; thus the benefit of variable coupling is lost.

Lastly, because of the relatively large frequency band that can be covered by a given klystron with ceramic windows, a smaller number of tube designs is required to cover a given frequency band, such as the uhf TV band. This simplifies the manufacturing problem and reduces the cost of the tube.

Another feature of interest is the use of a tantalum cathode heated by electron bombardment from a tungsten filament of relatively small size by means of a dc power supply (0.6 amps. at 2,000 volts) between the cathode and the filament. This constitutes a flexible system, and is much simpler to design and construct than a radiation-heated cathode.

CONCLUSIONS

The 3-cavity externally tunable klystron is excellently suited to high-power generation at uhf (and also at higher frequencies) because

- 1. it is relatively simple to manufacture,
- 2. it is easy to use and adjust,
- 3. the transmitter design and construction is simplified by its use,
- 4. its performance as an amplifier is greatly superior to other tube types.

It is likely that the future will see more and more such tubes in commercial service for an increasing variety of applications.

Reproduced from the PROCEEDINGS OF THE INSTITUTE OF RADIO ENGINEERS

VOL. 41, NO. 1, JANUARY, 1953

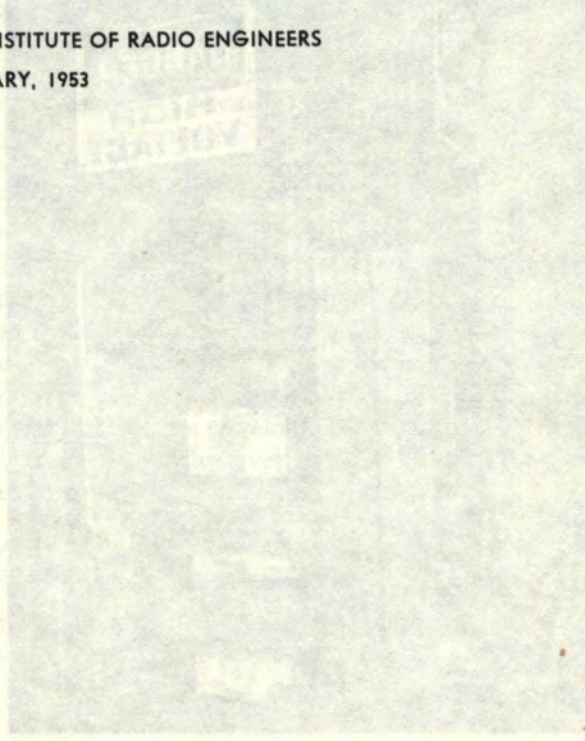

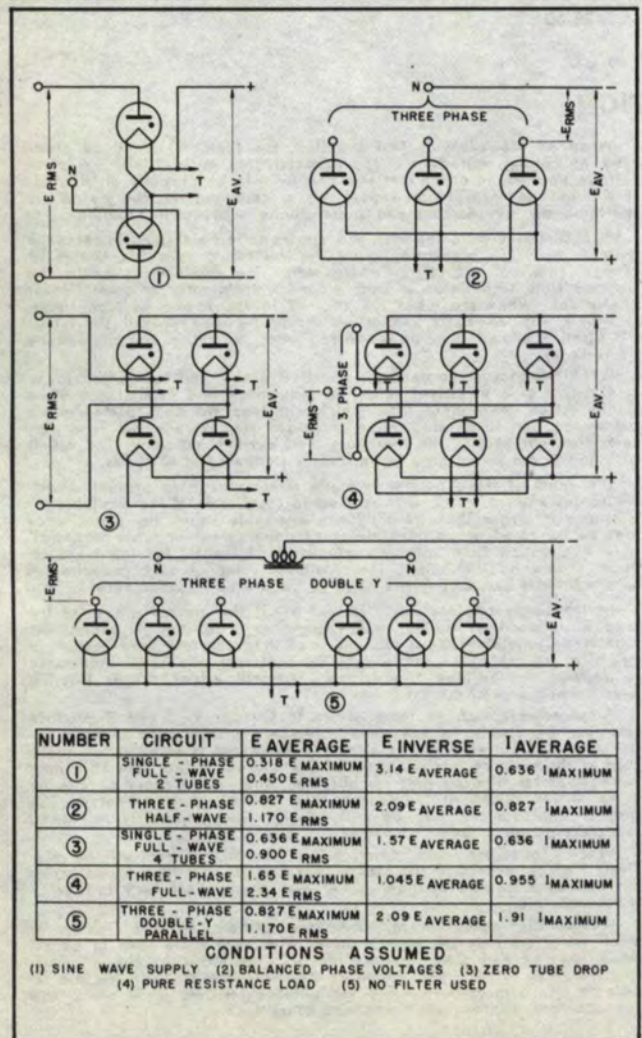
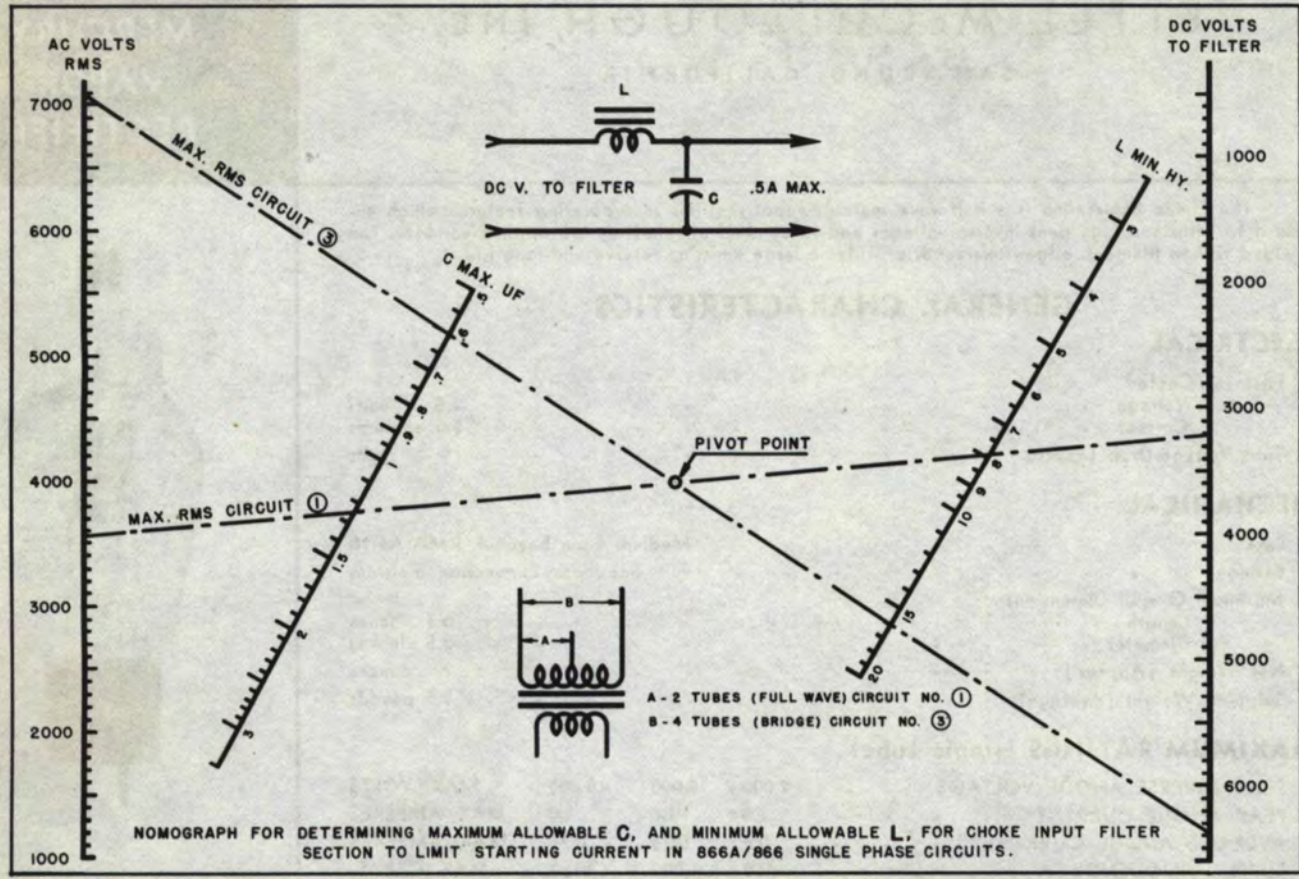

CIRCUIT	A-C INPUT VOLTS** (RMS)	MAX. D-C OUTPUT VOLTS TO FILTER	CHOKE INPUT ONE-SECTION FILTER		MAX. D-C LOAD CURRENT amperes
			MIN. CHOKE (L) henrys	MAX. CONDENSER TO (C) uf	
THREE-PHASE HALF-WAVE CIRCUIT 2	per leg	4780	3.2	1.4	0.75
	4080	3510	2.2	2.0	0.75
	3000	2340	1.4	3.0	0.75
	1500	1750	1.1	4.0	0.75
THREE-PHASE FULL-WAVE CIRCUIT 4	per leg	9570	1.8	0.5	0.75
	4080	7020	1.4	0.7	0.75
	3000	4680	0.9	1.2	0.75
	1500	3510	0.7	1.5	0.75
THREE-PHASE DOUBLE-Y PARALLEL CIRCUIT 5	per leg	4780	2.0	0.5	1.5
	4080	3510	1.5	0.7	1.5
	3000	2340	1.0	1.1	1.5
	1500	1750	0.7	1.5	1.5
SINGLE PHASE FULL-WAVE (2 tubes) CIRCUIT 1*	per tube	3535	—	—	0.25
	3000	3390	—	—	0.25
	2000	2260	—	—	0.25
	1500	1700	—	—	0.25

* With condenser input to filter.
**For use under the conditions of the 10000-volt peak inverse rating. If the 866-A/866 is to be used under frequency and/or temperature conditions such that the peak inverse voltage is limited to 5000 volts, the a-c input voltage and d-c output voltage values in the table should be multiplied by a factor of 0.5 to give new values for the 5000-volt conditions.

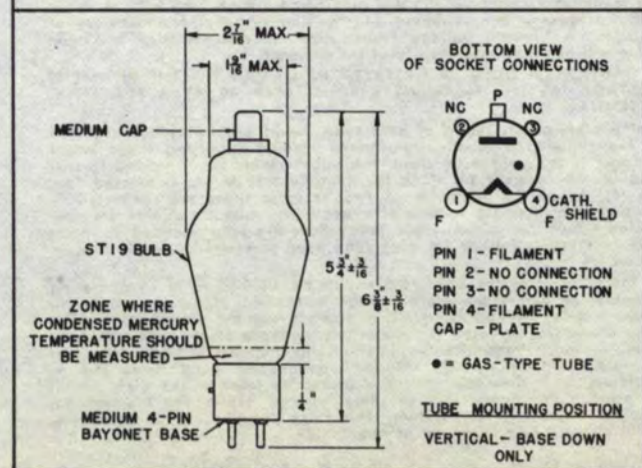

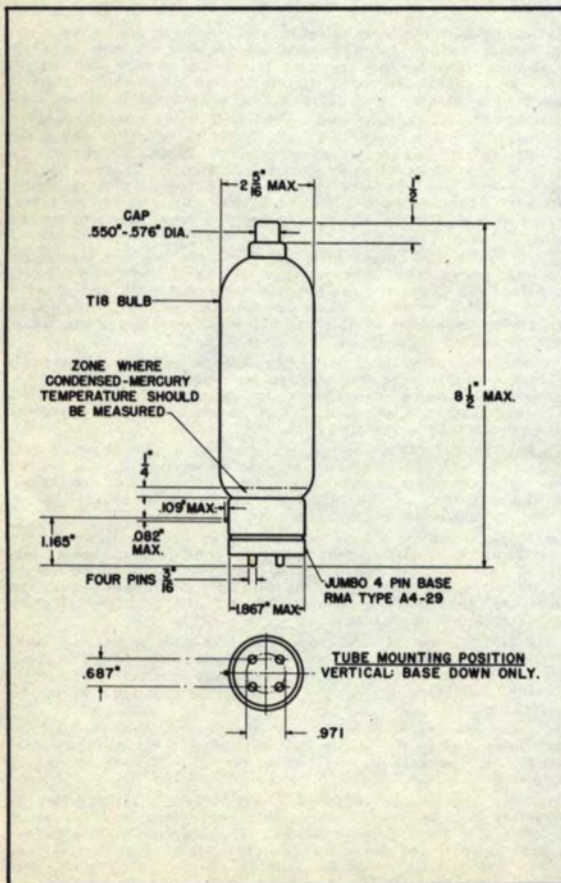
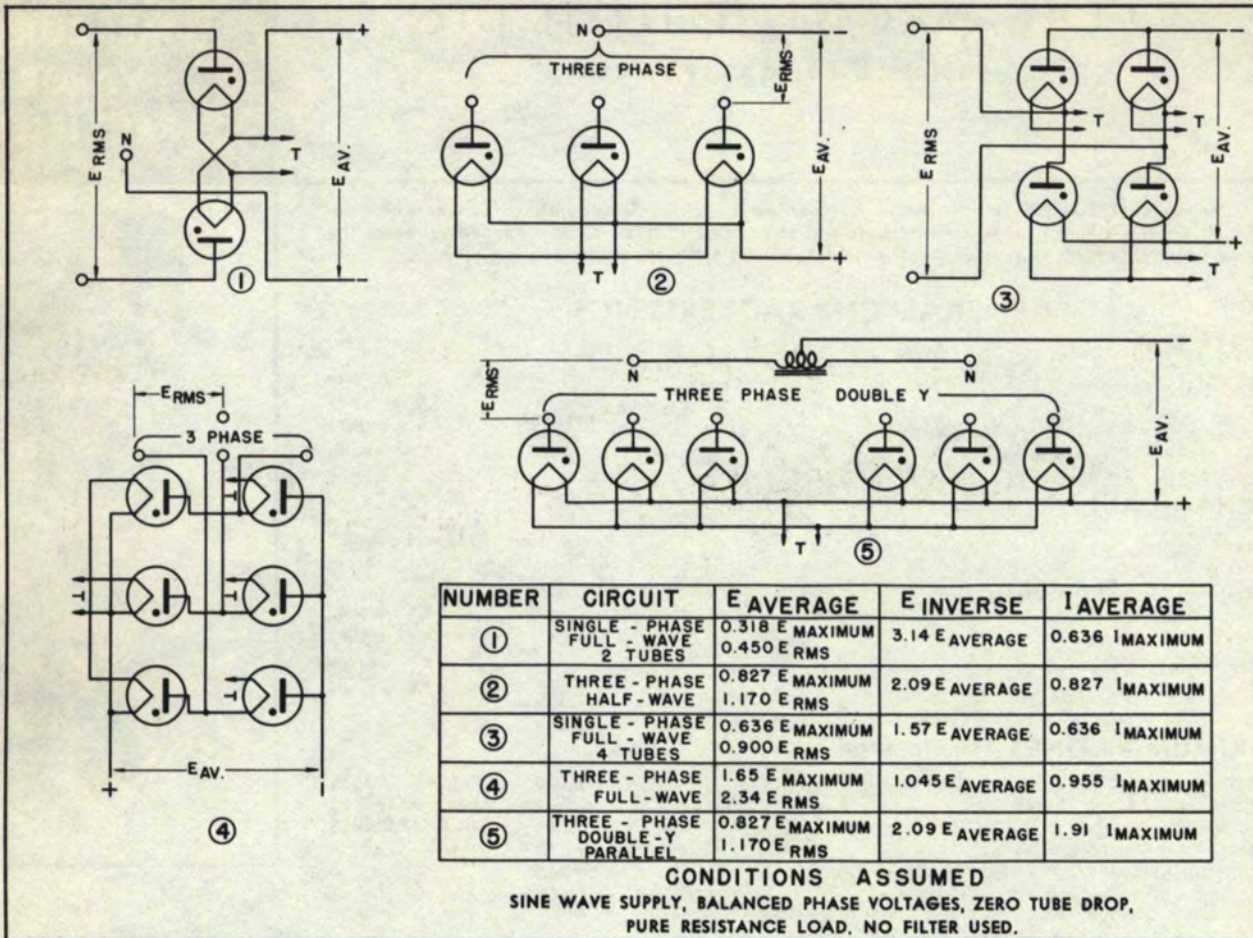

CIRCUIT	INPUT VOLTS/ MAXIMUM A-C (RMS)	APPROX. D-C OUTPUT VOLTS TO FILTER	MAXIMUM D-C OUTPUT CURRENT AMPERES
1	3535 per tube	3180	2.5
2	4080 per leg	4780	3.75
3	7070 total	6360	2.5
4	4080 per leg	9570	3.75
5	4080 per leg	4780	7.5

1 Max. peak inverse voltage of 10,000 volts.

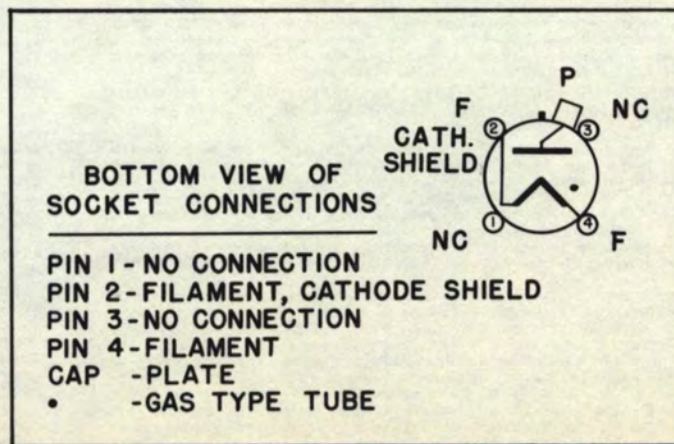

Eitel-McCullough, Inc.

SAN BRUNO, CALIFORNIA

VACUUM CAPACITORS

VC50-32	VC50-20
VC25-32	VC25-20
VC12-32	VC12-20
VC6-32	VC6-20

Eimac vacuum capacitors are small, vacuum-dielectric units intended principally for use as all or part of the plate tank capacitance in radio-frequency amplifiers or oscillators. They are also frequently used as high-voltage coupling and by-pass capacitors at high frequencies and as high-voltage neutralizing capacitors, when used in conjunction with small high-voltage variable capacitors having a small capacitance range. The use of a vacuum as a dielectric permits the construction of a comparatively small, lightweight capacitor for a given voltage rating and capacitance. In addition, the effects of dust and atmospheric conditions on the capacitor are eliminated by sealing the plates within a glass envelope.

These capacitors are manufactured in two maximum peak voltage ratings, 32,000 and 20,000 volts, and in capacitances of 6, 12, 25 and 50 uufd. All types have a maximum current rating of 28 amperes. Each of the capacitors may be operated at its full maximum voltage rating at any frequency below that at which the rms current through the capacitor is 28 amperes. Above this frequency, the r-f voltage across the capacitor must be reduced as the frequency increases, to prevent the current from exceeding the maximum rating. The graphs below show the maximum peak r-f voltage which may be applied to each type of capacitor at frequencies between 100 kilocycles and 50 megacycles. Curves are also shown which indicate the rms current flowing through the capacitor under maximum r-f voltage conditions at any frequency between 100 kilocycles and 50 megacycles. Where both r-f and d-c voltages are applied to the capacitor, the sum of the peak r-f and d-c voltages must not exceed the peak voltage rating of the capacitor.

Eimac vacuum capacitors are provided with terminals which allow the use of standard 60-ampere fuse clips for mounting. These clips must be kept clean and must at all times make firm and positive contact with the capacitor terminals. Failure to maintain a low-resistance contact to the capacitor terminals may result in excessive heating and permanent damage to the capacitor seals.

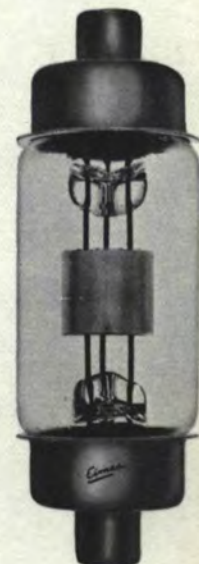

VC50-32

Capacitance* 50 $\mu\mu\text{fd.}$
 Max. Peak Voltage 32,000 volts
 Max. RMS Current 28 amps.

VC50-20

Capacitance* 50 $\mu\mu\text{fd.}$
 Max. Peak Voltage 20,000 volts
 Max. RMS Current 28 amps.

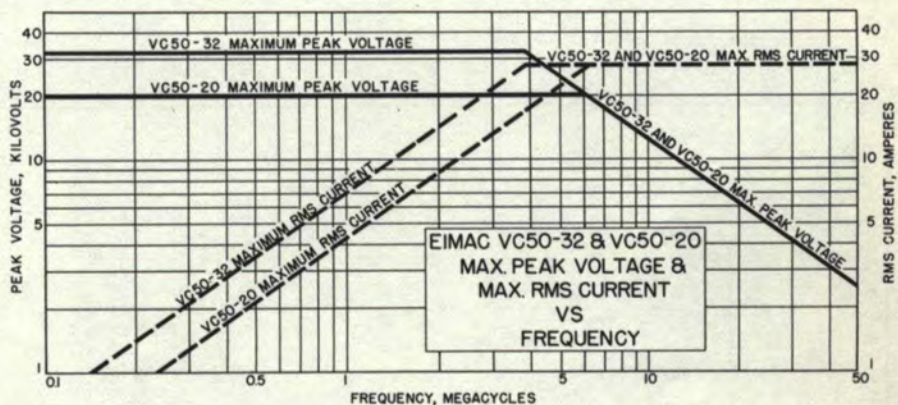

VC25-32

Capacitance* 25 $\mu\mu\text{fd.}$
 Max. Peak Voltage 32,000 volts
 Max. RMS Current 28 amps.

VC25-20

Capacitance* 25 $\mu\mu\text{fd.}$
 Max. Peak Voltage 20,000 volts
 Max. RMS Current 28 amps.

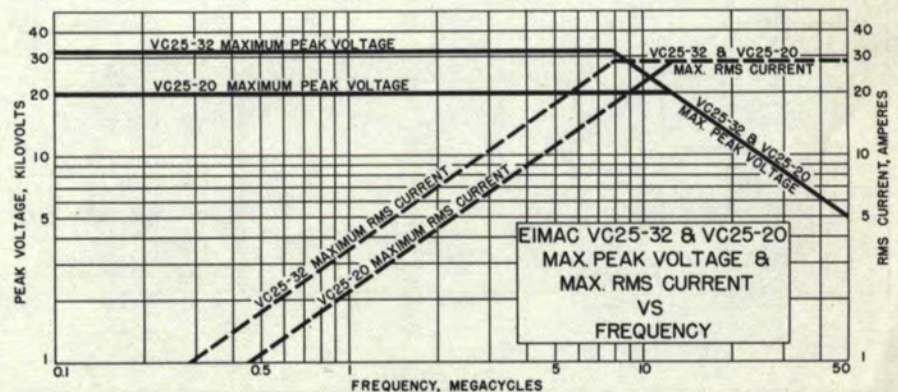

Eitel-McCullough, Inc.

SAN BRUNO, CALIFORNIA

VACUUM CAPACITORS

VC50-32	VC50-20
VC25-32	VC25-20
VC12-32	VC12-20
VC6-32	VC6-20

Eimac vacuum capacitors are small, vacuum-dielectric units intended principally for use as all or part of the plate tank capacitance in radio-frequency amplifiers or oscillators. They are also frequently used as high-voltage coupling and by-pass capacitors at high frequencies and as high-voltage neutralizing capacitors, when used in conjunction with small high-voltage variable capacitors having a small capacitance range. The use of a vacuum as a dielectric permits the construction of a comparatively small, lightweight capacitor for a given voltage rating and capacitance. In addition, the effects of dust and atmospheric conditions on the capacitor are eliminated by sealing the plates within a glass envelope.

These capacitors are manufactured in two maximum peak voltage ratings, 32,000 and 20,000 volts, and in capacitances of 6, 12, 25 and 50 uufd. All types have a maximum current rating of 28 amperes. Each of the capacitors may be operated at its full maximum voltage rating at any frequency below that at which the rms current through the capacitor is 28 amperes. Above this frequency, the r-f voltage across the capacitor must be reduced as the frequency increases, to prevent the current from exceeding the maximum rating. The graphs below show the maximum peak r-f voltage which may be applied to each type of capacitor at frequencies between 100 kilocycles and 50 megacycles. Curves are also shown which indicate the rms current flowing through the capacitor under maximum r-f voltage conditions at any frequency between 100 kilocycles and 50 megacycles. Where both r-f and d-c voltages are applied to the capacitor, the sum of the peak r-f and d-c voltages must not exceed the peak voltage rating of the capacitor.

Eimac vacuum capacitors are provided with terminals which allow the use of standard 60-ampere fuse clips for mounting. These clips must be kept clean and must at all times make firm and positive contact with the capacitor terminals. Failure to maintain a low-resistance contact to the capacitor terminals may result in excessive heating and permanent damage to the capacitor seals.

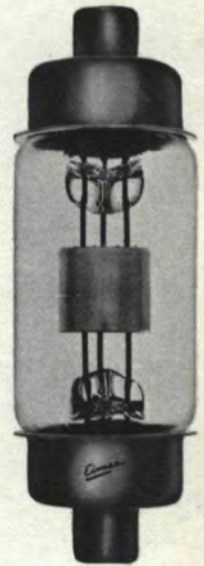

VC50-32

Capacitance* 50 $\mu\mu\text{fd}$.
 Max. Peak Voltage 32,000 volts
 Max. RMS Current 28 amps.

VC50-20

Capacitance* 50 $\mu\mu\text{fd}$.
 Max. Peak Voltage 20,000 volts
 Max. RMS Current 28 amps.

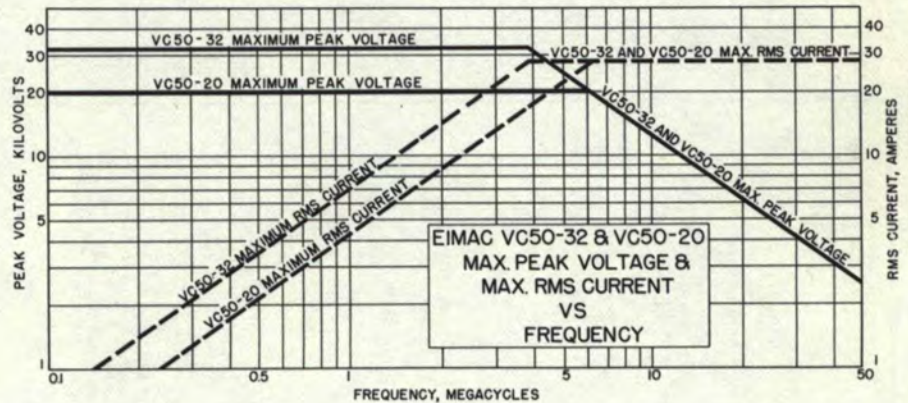

VC25-32

Capacitance* 25 $\mu\mu\text{fd}$.
 Max. Peak Voltage 32,000 volts
 Max. RMS Current 28 amps.

VC25-20

Capacitance* 25 $\mu\mu\text{fd}$.
 Max. Peak Voltage 20,000 volts
 Max. RMS Current 28 amps.

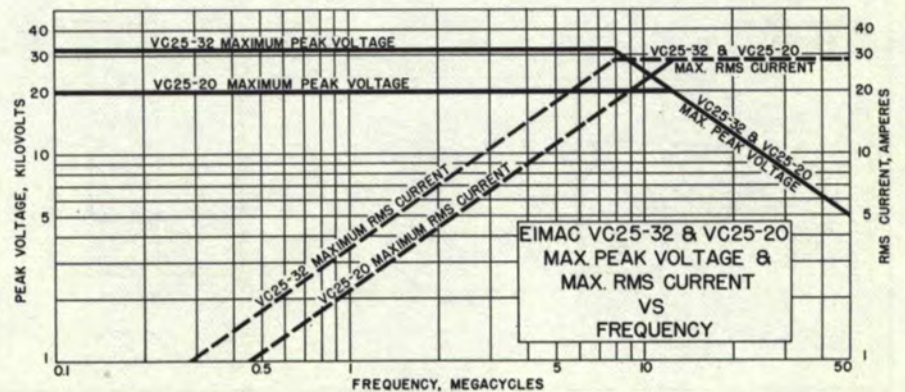

TYPES VVC 60-20 VVC2-60-20 VVC4-60-20

GENERAL

Eimac variable vacuum capacitors are intended principally for use as plate tank capacitors in radio frequency amplifiers and oscillators. The use of vacuum for the dielectric permits close spacing of the electrodes giving concentrated capacitance at high voltage. The variable vacuum capacitors are compact, lightweight, and eliminate the effects of dust and atmospheric conditions.

The basic capacitor unit (VVC60-20) has an RF peak voltage rating of 20,000 volts and a maximum current rating of 40 amperes RMS. Ganged multiple unit capacitors are available using two units (VVC2-60-20) or four units (VVC4-60-20). These multiple unit capacitors include a single mounting plate, gear train, and single tuning shaft. One end of each unit capacitor mounts on the common plate and one end is free. Thus the multiple capacitor may be connected with the units in parallel, as two series capacitors for "split-stator" work, or as multiple capacitors with one terminal common.

The capacitors may be operated at a maximum voltage rating at any frequency provided the current rating is not exceeded. Above a particular frequency the maximum current rating becomes the limitation and voltage values less than the maximum must be used. Curves are given for each capacitor showing maximum allowable current (RMS) vs. frequency.

The capacitance variation is linear with respect to shaft rotation with the complete range being covered in seventeen revolutions of the shaft. Reference should be made to the tuning curve for each capacitor. A return to previously-indexed settings is positive. The variable vacuum capacitors have a low temperature coefficient resulting in a negligible change in capacitance due to variation in temperature. The actual coefficient values are given for each capacitor combination.

MOUNTING

The VVC60-20 is provided with a mounting plate on one end, which also serves as an electrical

connection. If the circuit is such that one side of the capacitor is grounded, the mounting plate can be fastened directly to the panel or chassis. Four eyelets to accommodate No. 8-32 machine screws are provided on the mounting plate. If a single or multiple unit is to be ungrounded the mounting should be on insulators and the tuning shaft broken with an insulating coupling and the dial portion of the shaft grounded.

The other end of the capacitor is provided with a large terminal that permits the use of a simple clamp or collet connector. This connector should be mounted flexibly to prevent undue mechanical strain being put on the capacitor seals. The connector must be kept clean and must at all times make a firm and positive contact with the capacitor terminal. Failure to maintain a low resistance contact to the capacitor terminal may result in excessive heating and permanent damage to the capacitor seals.

The multiple unit capacitor is designed so that it may be mounted readily on the chassis or from a panel. The mounting plate serves as one electrical connection and can be mounted directly at ground potential or insulated above ground.

The capacitors require normal circulation of air to keep the metal-to-glass seals below the maximum permissible temperature when carrying large values of current. In cases where the air flow is restricted or the ambient temperature is above room temperature a measurement of the seal temperature should be made. Adequate cooling must be provided to keep the metal of the metal-to-glass seals below 150° centigrade.

The low-torque tuning mechanism provides easy hand-operation of a dial directly on the shaft of either the single or multiple-unit capacitors. The capacity of type VVC vacuum condensers may be controlled by an electric tuning motor providing a minimum of two inch-pounds of torque per unit. The use of positive-action limit switches or a slip-coupling is recommended to avoid forcing the mechanism when it reaches the limit of its travel in either direction.

VVC 60-20
VARIABLE
VACUUM
CAPACITOR

Eimac
EITEL-McCULLOUGH, INC.
 SAN BRUNO, CALIFORNIA



The VVC60-20 is a single unit variable vacuum capacitor.

CHARACTERISTICS

ELECTRICAL

Capacitance		
Maximum	60 mmfd	
Minimum	10 mmfd	
Number of revolutions (See Curve)	17 turns	
Maximum Peak R.F. Voltage	20 kilovolts	
Maximum Current (RMS)	40 amperes	
(See derating curve vs frequency)		
Temperature Coefficient	+ .004 mmfd/°C	

MECHANICAL

Mounting	See Outline Drawing
Cooling	Air Convection
Maximum Seal Temperature	150°C.
Maximum Overall Dimensions	
Length	5-11/16"
Diameter	3- 1/16"
Net Weight	1 lb. 6 oz.
Shipping Weight (average)	2 lb.

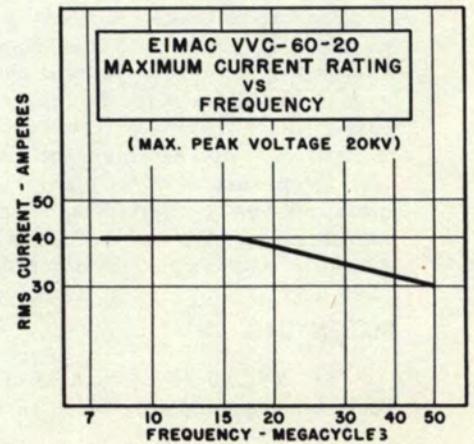
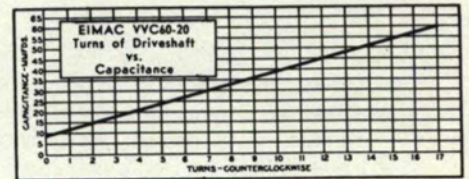
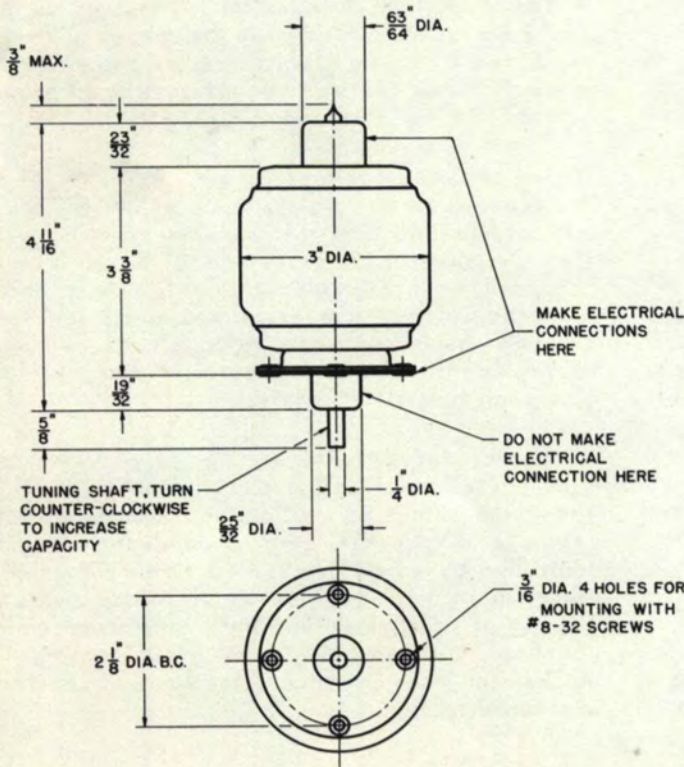

The VVC2-60-20 is a dual unit variable vacuum capacitor consisting of two VVC60-20 units in a convenient gang mounting.

ELECTRICAL

CHARACTERISTICS

	Parallel	Split Stator	
Capacitance			
Maximum	120	30	mmfd
Minimum	20	5	mmfd
Number of revolutions (See Curves)	17	17	turns
Maximum Peak R.F. Voltage.....	20	40	kilovolts
Maximum Current (RMS)	80	40	amperes
(See derating vs frequency)			
Temperature Coefficient	+ .008	+ .002	mmfd/°C

MECHANICAL

Mounting	See Outline Drawing
Cooling	Air Convection
Maximum Seal Temperature.....	150° C
Maximum Overall Dimensions	
Depth	6-9/32"
Height	3-1/8"
Width	8-1/8"
Net Weight	4 lbs.
Shipping Weight (approx.)	8 lbs.

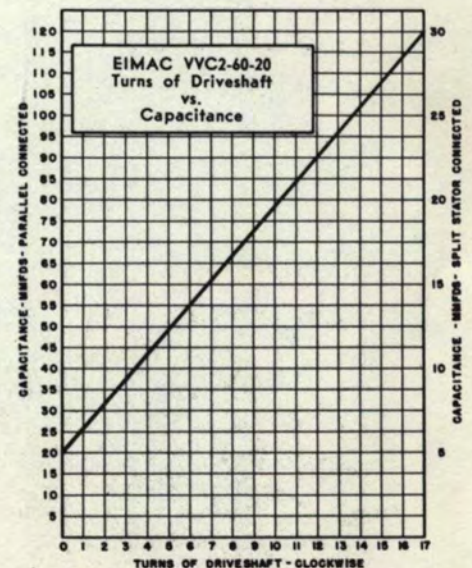
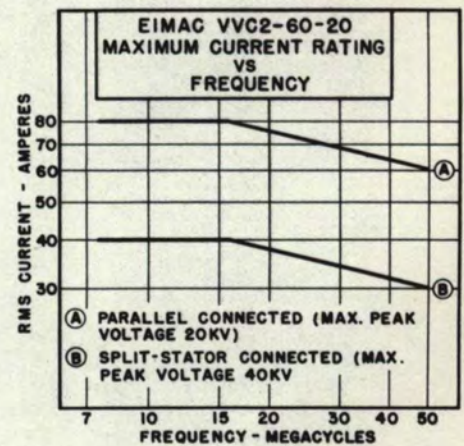
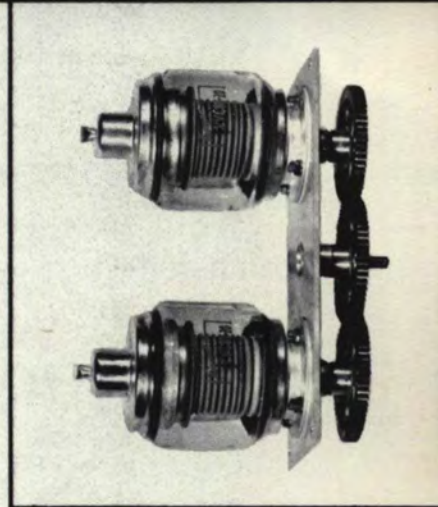
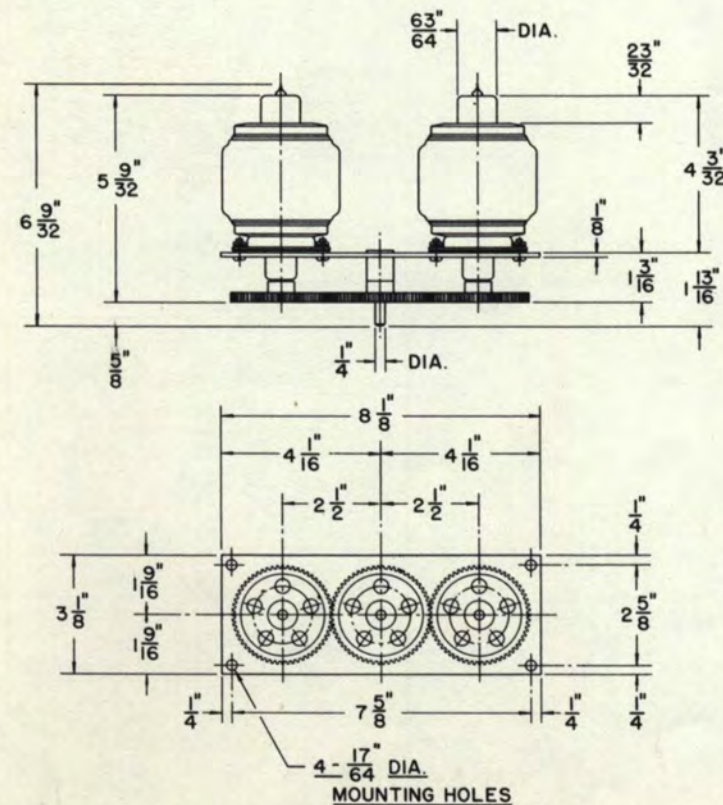

Effective 3-1-49

If You Didn't Get This From My Site,
Then It Was Stolen From...

VVC4-60-20
VARIABLE
VACUUM
CAPACITOR

Eimac
EITEL-McCULLOUGH, INC.
 SAN BRUNO, CALIFORNIA

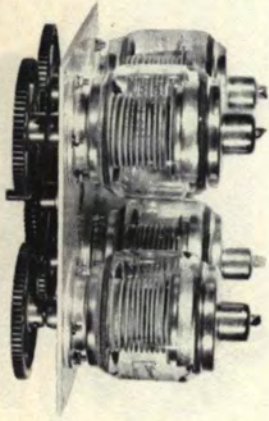

The VVC4-60-20 is a four unit variable vacuum capacitor consisting of four VVC60-20 units in a convenient gang mounting.

CHARACTERISTICS

ELECTRICAL

	Parallel	Split Stator	
Capacitance			
Maximum	240	60	mmfd
Minimum	40	10	mmfd
Number of revolutions (See Curves)	17	17	turns
Maximum Peak R.F. Voltage.....	20	40	kilovolts
Maximum Current (RMS).....	160	80	amperes
(See derating curve vs frequency)			
Temperature Coefficient	+0.016	+0.004	mmfd/°C

MECHANICAL

Mounting	See Outline Drawing
Cooling	Air Convection
Maximum Seal Temperature.....	150°C
Maximum Overall Dimensions	
Depth	6- 9/32"
Height	7-13/16"
Width	7-13/16"
Net Weight	8 lbs.
Shipping Weight (approx.)	14 lbs.

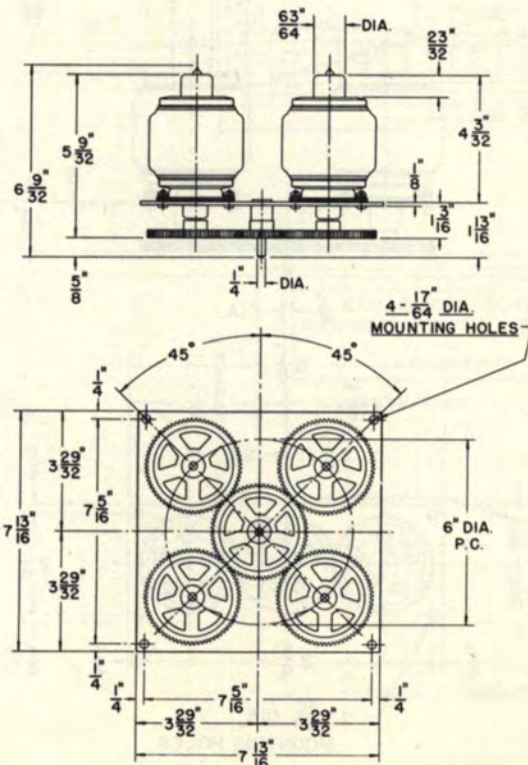
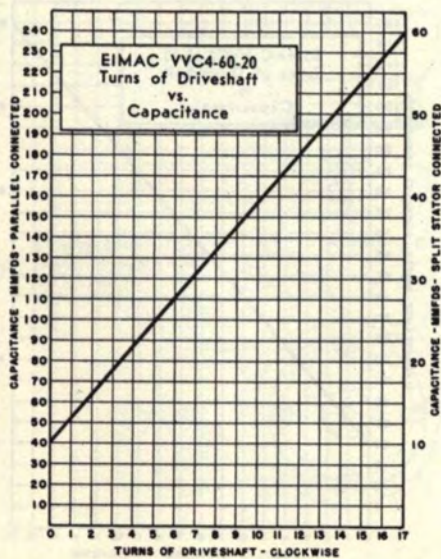
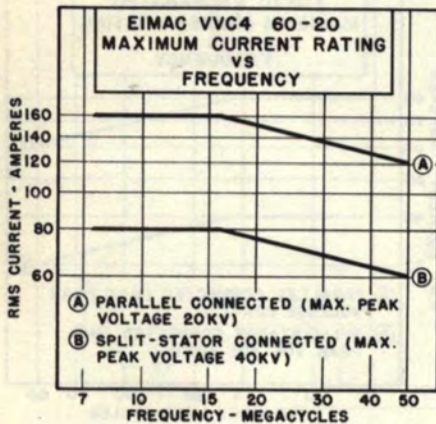

PREFORMED CONTACT FINGER STOCK

▶ Eimac Preformed Contact Finger Stock is a prepared strip of spring material slotted and formed into a series of fingers designed to make sliding contact.

Eimac Finger Stock is an excellent means of providing good circuit continuity when using components with adjustable or moving contact surfaces. It is especially suitable for making connections to tubes with coaxial terminals, or to moving parts, such as long-line and cavity type circuits; and it is also useful in acting as an electrical "weather-strip" around access doors to equipment cabinets.

The material is a heat treated alloy; and is silver plated for better r-f conductivity. No further forming of the material should be attempted. Eimac Finished Finger Stock has a minimum radii of curvature of $\frac{1}{2}$ " for the 17/32" type, and $\frac{3}{4}$ " for both the 31/32" and 1 - 7/16" types. It may be secured by any suitable mechanical means or by soft soldering.

Eimac Finger Stock can be obtained to order in a raw state (punched, formed, unplated and not heat treated). The Raw Finger Stock can be formed to different shapes by the user but it then must be carefully heat treated. Finished Finger Stock receives a closely controlled and uniform heat treatment as follows: 375°-385°C. for 5 hours in a neutral gas atmosphere. No special cooling considerations are necessary, except those required to avoid oxidation. Eitel-McCullough will not undertake to heat treat or plate Raw Finger Stock after being further formed by a customer. For further information concerning the heat treatment of the Finger Stock material, Alloy No. 720, write the supplier of the material:

General Plate Division
Metals and Control Corporation
Attleboro, Massachusetts

Standard lengths of either Raw or Finished Finger Stock are 1 foot, 2 feet and 3 (maximum) feet. Some small variation about the standard lengths should be expected.

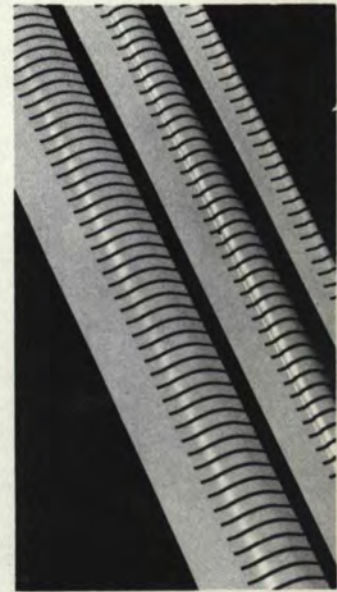

Eimac Tubes and Contact Surfaces for which Finger Stock is especially suitable.	PLATE	GRID	SCREEN GRID	CATHODE
3W10,000A3	1 - 7/16	31/32		17/32
3W5000A3	1 - 7/16	17/32		
3W5000F3	1 - 7/16	17/32		
3X3000A1	1 - 7/16	17/32		
3X3000F1	1 - 7/16			
3X2500A3	1 - 7/16	17/32		
3X2500F3	1 - 7/16			
4X500A	31/32		31/32	
4X500F	31/32			
4X150A	17/32		17/32	
4X150D	17/32		17/32	
4X150G	17/32		17/32	
2C39A	17/32			

▶ Indicates change from sheet dated 9-15-51.

(Effective 3-10-53) Copyright, 1953 by Eitel-McCullough, Inc.

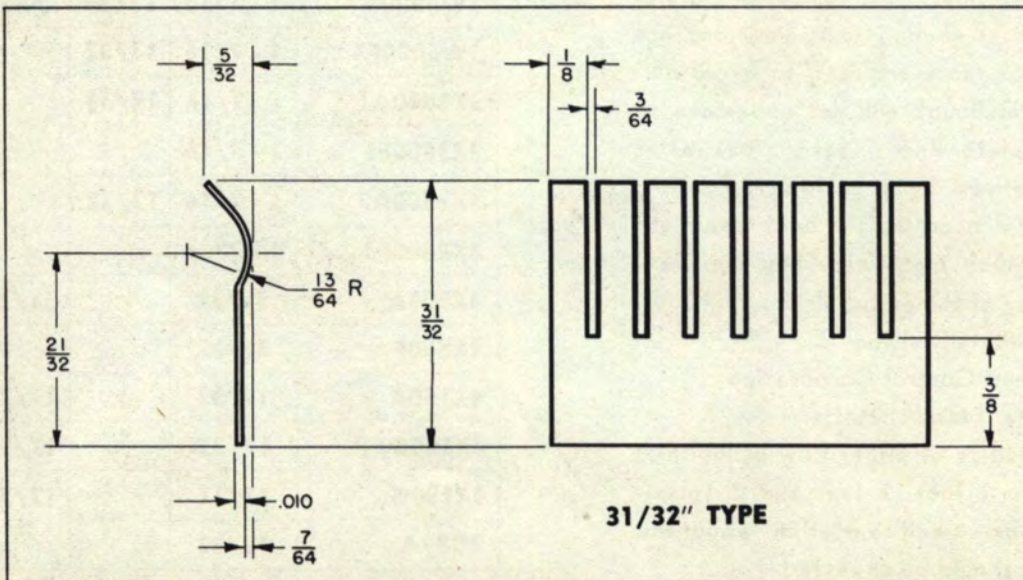
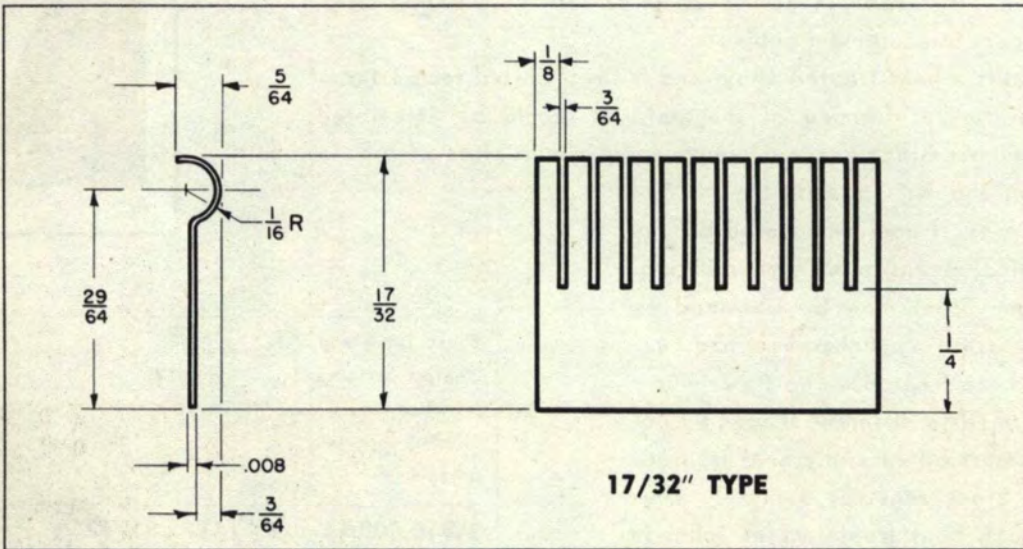
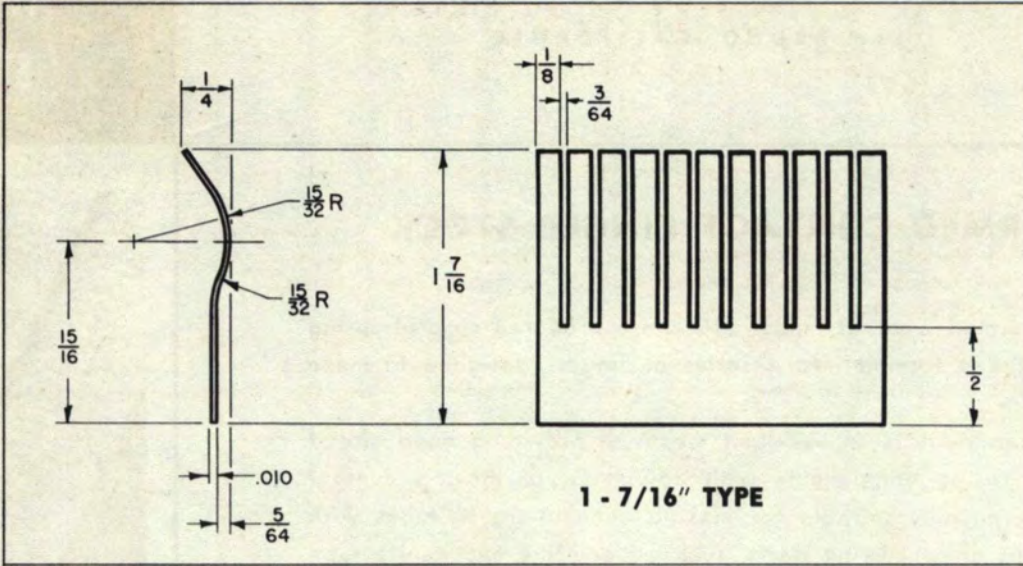

NOTE—The above dimensions should be regarded as carrying normal manufacturing tolerances because of variations in the shearing, forming and heat-treating processes.

Eitel-McCullough, Inc.

SAN BRUNO, CALIFORNIA

HR HEAT DISSIPATING CONNECTORS

Eimac HR Heat Dissipating Connectors are used to make electrical connections to the plate and grid terminals of Eimac tubes, and, at the same time, provide efficient heat transfer from the tube element and glass seal to the air. The HR connectors aid materially in keeping seal temperatures at safe values. However, it is sometimes necessary to forced-air-cool the connector by means of a small fan or blower. In such cases the air flow should be parallel with the fins of the connector.

Designed for use on the larger tubes, the HR-9 Heat Dissipating Connector is provided with an air duct to conduct the cooling air directly to the glass seal.

HR Heat Dissipating Connectors are machined from solid dural rod, and are supplied with the necessary machine screws. The table below lists the proper connectors for use with each Eimac tube type.

TUBE	PLATE CONNECTORS	CONNECTOR GRID	TUBE	PLATE CONNECTORS	CONNECTOR GRID
2-25A	HR-1	75TH-TL	HR-3	HR-2
2-50A	HR-3	100R	HR-8
2-150D	HR-6	100TH-TL	HR-6	HR-2
2-240A	HR-6	VT127A	HR-3	HR-3
2-2000A	HR-8	152TH-TL	HR-5	HR-6
3C24	HR-1	HR-1	250TH-TL	HR-6	HR-3
4-65A	HR-6	250R	HR-6
4-125A	HR-6	253	HR-8
4-250A	HR-6	304TH-TL	HR-7	HR-6
4-400A	HR-6	327A	HR-4	HR-3
4-1000A	HR-8	450TH-TL	HR-8	HR-8*
▶ 4E27A / 5-125B	HR-5	▶ 592 / 3-200A3	HR-10	HR-5
▶ 4PR60A	HR-8			
▶ 6C21	HR-8	HR-8			
KY21A	HR-3	750TL	HR-8	HR-8
RX21A	HR-3	866A	HR-8
25T	HR-1	872A	HR-8
35T	HR-3	1000T	HR-9	HR-9
35TG	HR-3	HR-3	▶ 1500T	HR-8	HR-8
UH50	HR-2	HR-2	▶ 2000T	HR-8	HR-8

*The grid terminal of the 450TH-TL type tube is now .560" in diameter. To accommodate existing equipment designed for the older style 450TH-TL having .098" diameter grid terminals, an adapter pin is provided with the newer tubes. This adapter pin is threaded so that it may be removed from the grid terminal of the tube. The small grid terminal requires an HR-4 connector.

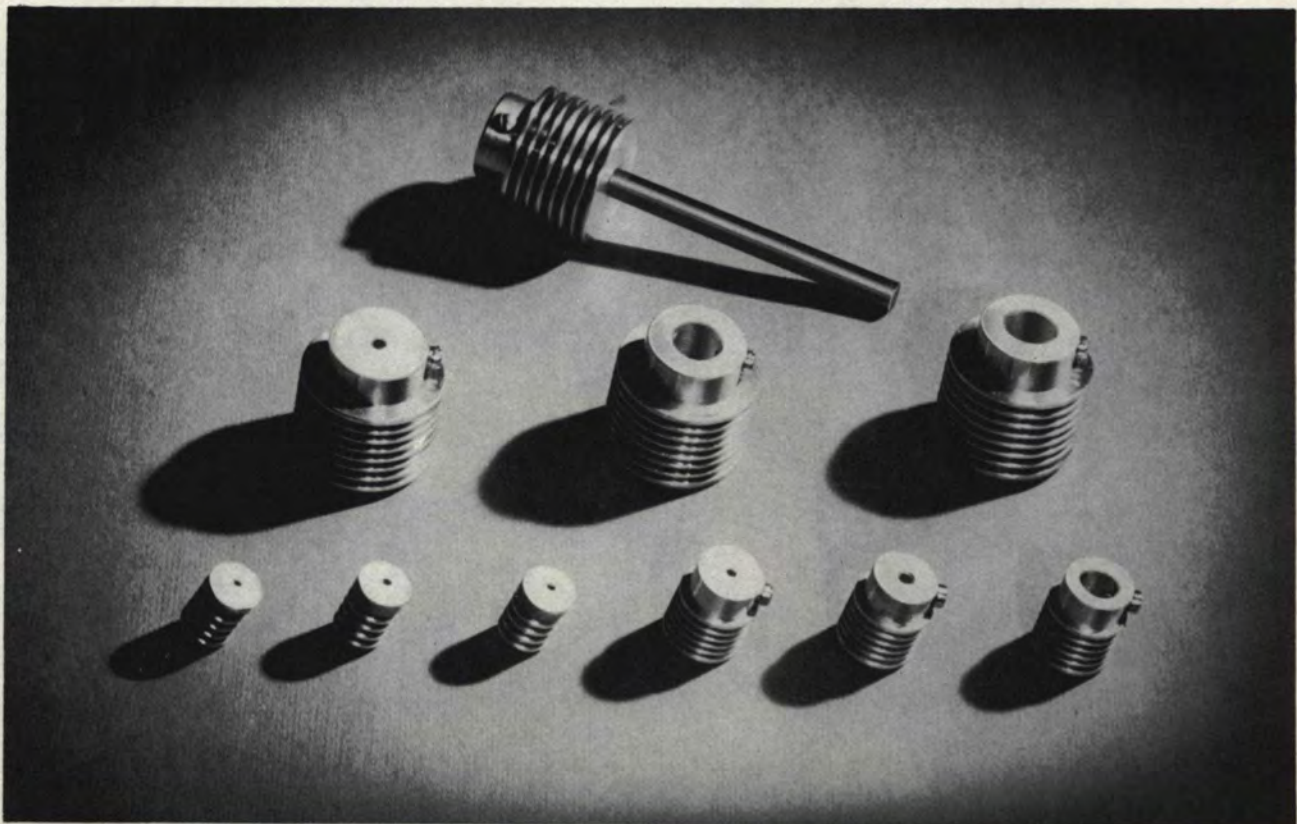

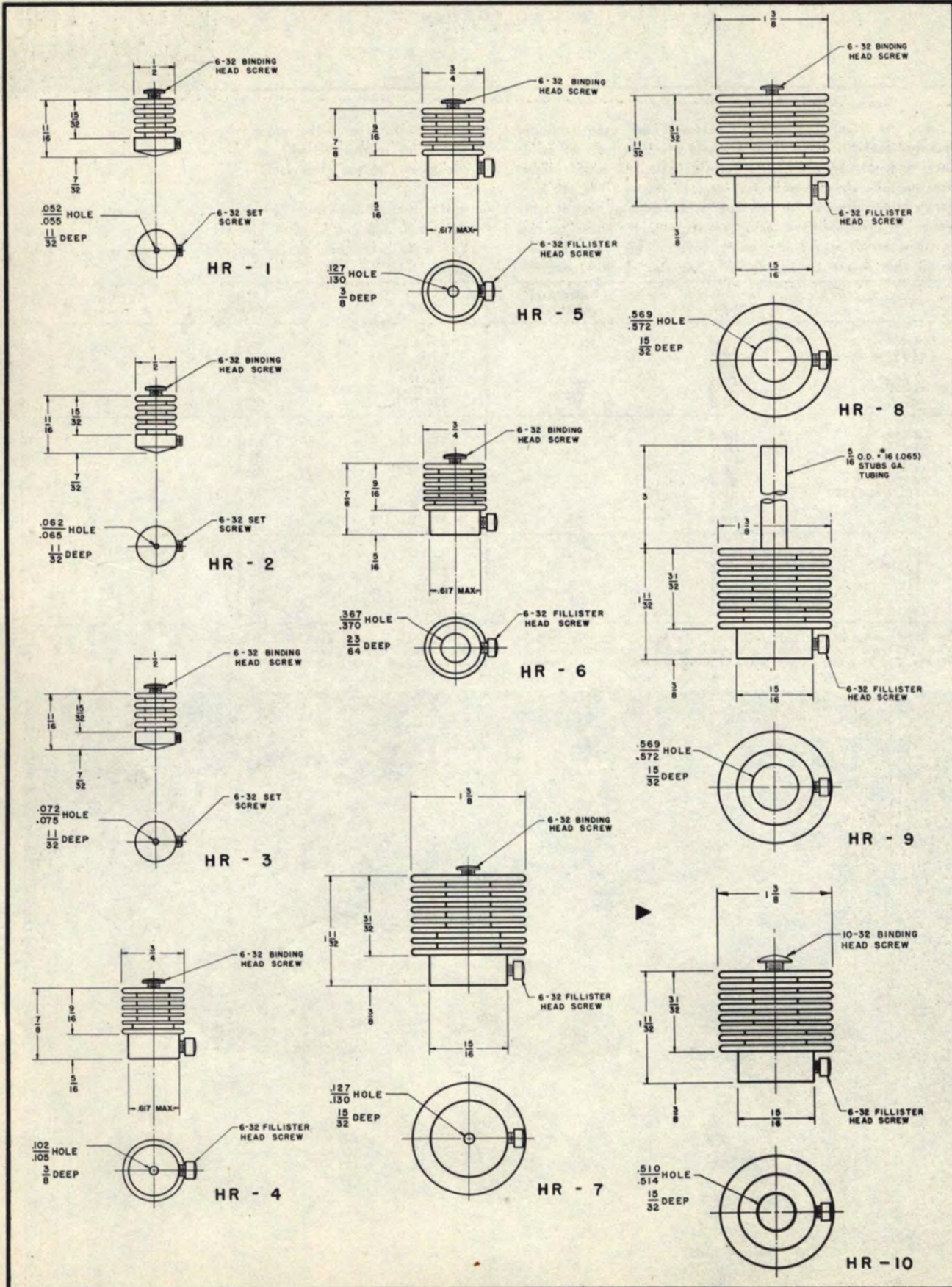

THE CARE AND FEEDING OF POWER TETRODES



APPLICATION BULLETIN NUMBER EIGHT
EITEL-MCULLOUGH-INC.
SAN BRUNO CALIFORNIA

PRICE TWENTY-FIVE CENTS

The information presented herein is based on data believed accurate, but no responsibility is accepted for the successful application of the systems or principles discussed. Likewise, no responsibility is assumed for patent infringement, if any, resulting from the application of this information.

Published by the Field Engineering Department of Eitel-McCullough, Inc.
Copyright 1951, Eitel-McCullough, Inc. Printed in U.S.A.

THE CARE AND FEEDING OF POWER TETRODES

CONTENTS

SECTION	PAGE
A. INTRODUCTION	1
B. LAYOUT	2
1. General	2
(a) Shielding	2
(b) Air Cooling	4
2. Component Parts	5
3. Lead Lengths	5
4. Filament Bypassing	6
5. Screen Bypassing and Series Screen Tuning	6
C. CIRCUIT DESIGN CONSIDERATIONS	7
1. Basic Circuits	7
2. Bypassing, Filtering, Screening	8
3. Power Supply Considerations	8
4. Protection	9
5. Keying	10
6. Modulating	11
D. CIRCUIT ADJUSTMENT AND CHOICE OF OPERATING CONDITIONS	12
1. Stabilizing the Amplifier	12
(a) Testing for Parasitic Oscillations	12
(b) Correction of Parasitic Oscillations	12
2. Neutralization	14
(a) Procedure	16
(b) Analysis of Circuits	17
(c) Self-Neutralization of VHF Parasitics	18
3. Properly Adjusting Loading and Excitation	19
4. Operating Voltages and Currents for Various Applications	19
5. Effect of Different Screen Voltages	20
6. Balance of Push-Pull Amplifiers	20
7. Harmonic Amplifiers and Control of Harmonics	21
8. Driving Power Requirements	21
9. VHF and UHF Operating Conditions	22
E. LIFE	22
1. Maximum Tube Ratings	22
2. Cooling	23
3. VHF and UHF Life Considerations	23
(a) Connectors	23
(b) Tube Temperatures	23
(c) Backheating by Electrons	24
F. TECHNICAL ASSISTANCE	25
REFERENCES	25

INTRODUCTION

The user of transmitting tubes is no doubt familiar with the usual r-f circuits built around neutralized triodes, and the many considerations in layout, circuit design, adjustment, keying, modulation, and care required to get the best performance and life for his particular needs. He probably is not so familiar with an accumulation of factual experience using the latest designs of the four-electrode transmitting tube, the tetrode.

It is the purpose of this application bulletin to cite some of the experience which has been had with current and new tetrodes to help users obtain the full capabilities of the tubes.

Briefly stated these new tubes:

1. Have internal feedback coupling reduced to a very small value.
2. Permit design of amplifier stages which operate with driving power less than 1% of output power in most cases, and with negligible driving power in many audio cases.
3. Operate efficiently and with good life at audio and radio frequencies, including the VHF region (30 to 300 Mc.) and in some cases into the UHF region (300 to 3000 Mc.).

4. Take abuse (providing it's done intelligently and not with a hammer).

5. Allow designers to build compact, simple, flexible equipment with the least chance of spurious interfering radiations.

The practical desired results, however, can not be had unless the design, adjustment and operation of the complete equipment are right. This recital of some experience with Eimac tetrodes can not presume to supply the normal skill and good techniques necessary to build successful electronic equipment. It may make it easier by showing layouts, circuit considerations, adjustment techniques, and operating values, which have worked. In many ways the problem is little different from building successful equipment with triodes.

The bulletin tries to give a general understanding, and clues to understanding, some of the behavior of circuits using tetrodes. For specific ratings, operating values and information on a particular tube type, the technical data sheet for the tube type should be studied. It comes with the tube, or may be had for the asking.



Fig. 1

Well arranged, filtered, and shielded r-f amplifier. Designed and built by R. L. Norton (W6CEM), and in use at WIFH.

LAYOUT

B-1. General

The metallic enclosure in which the tetrode or tetrodes operate serves the following three purposes:

1. Completes the shielding between the output (plate circuit) and the input (grid circuit).
2. It channels the forced cooling air, or convection air currents, so as to cool the tube adequately and, incidentally, the associated component parts as well.
3. It confines the radio frequency energy and helps permit selection of the desired frequency as the only one to be coupled out to the useful load circuit.

A good example of a suitable enclosure is shown in Fig 1.

B-1-a. Shielding

By referring to Figs. 2, 3, 4, 5, and 6, one

can readily see several r-f layouts which have been satisfactory in practice. Note that in all cases the tube is mounted vertically with the base down, and the socket is mounted flush with the deck separating the compartment below the tube and the compartment above the tube. In all cases the grid and filament (or cathode terminals) are on the base end of the tube and extend into the lower compartment. The plate circuit and plate terminal are in the upper compartment.

In the case of tubes having metal base shells, grounding clips should be carried by the bolts mounting the socket so as to bring the base shell to chassis potential. This completes the shielding between the output and input circuits since the base shell of the tube comes up opposite the screen shield within the tube itself.

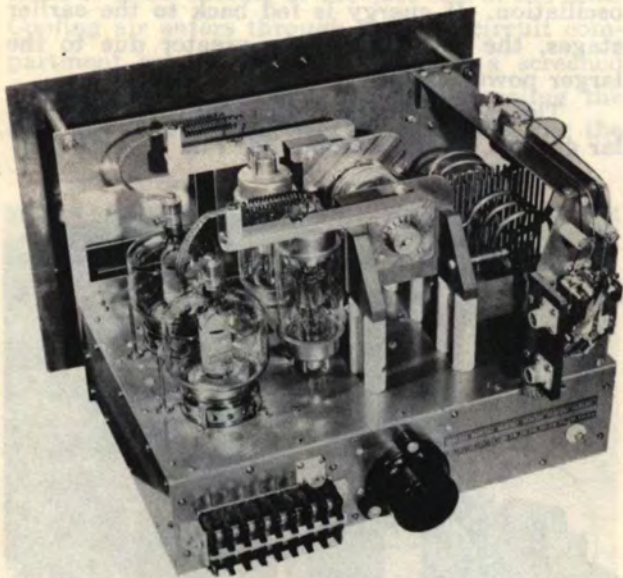
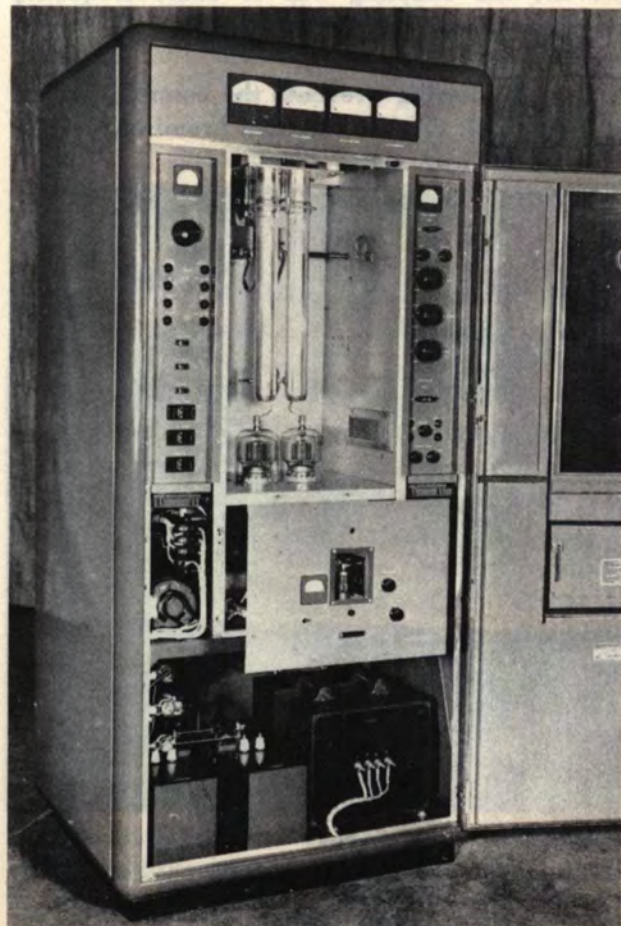

Fig. 2

Push-pull r-f amplifier employing 4-250A tetrodes.
Designed and built by C. F. Bane (W6WB)*.

Fig. 3

Push-pull 88-108 Mc. 1 Kw. amplifier employing 4-400A tetrodes. Radio Engineering Laboratories, Model 701 transmitter.



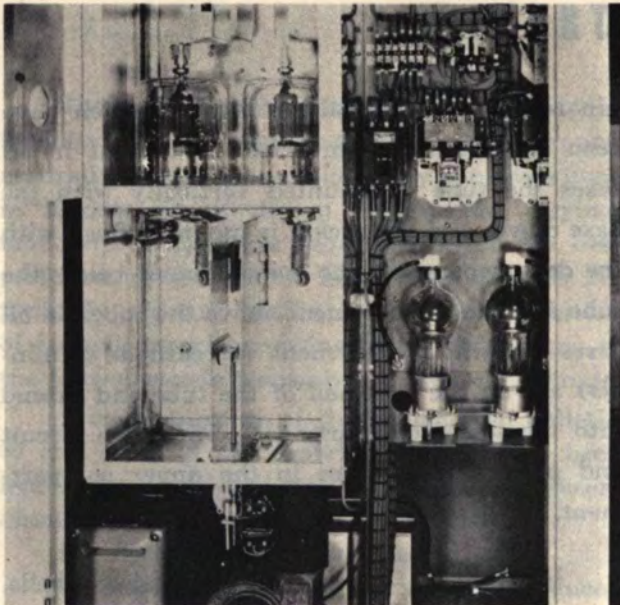

Fig. 4

Push-pull 110 Mc. amplifier employing 4-1000A tetrodes. Gates Radio Co. Model BF 3 kw transmitter.

By having the tube and circuits in completely enclosed compartments and by properly filtering incoming supply wires, it is possible to prevent the coupling out of radio frequency energy by means other than the desired output coupling.

Such filtering prevents the coupling out of energy which may be radiated promiscuously or

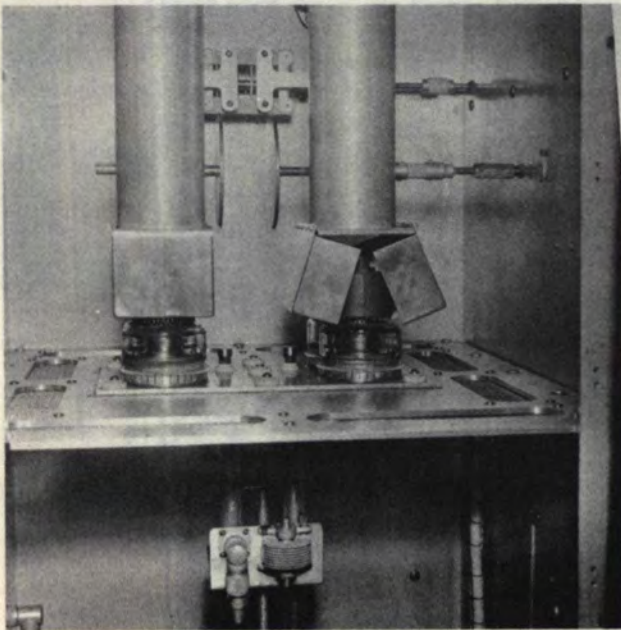

Fig. 5

Experimental push-pull parallel 110 Mc. 3 kw amplifier employing 4X500A tetrodes. Designed and built by Eitel-McCullough Laboratories.



Fig. 6

Experimental 950 Mc. doubler final and tripler driver employing 4X150A tetrodes. Designed and built by Eitel-McCullough Laboratories.

be fed back to the input or earlier stages to cause trouble. Energy fed back to the input circuit causes undesirable interaction in tuning, or self oscillation. If energy is fed back to the earlier stages, the trouble may be greater due to the larger power gain over several stages.

The layout for an audio stage follows similar general arrangements. See Fig. 7.

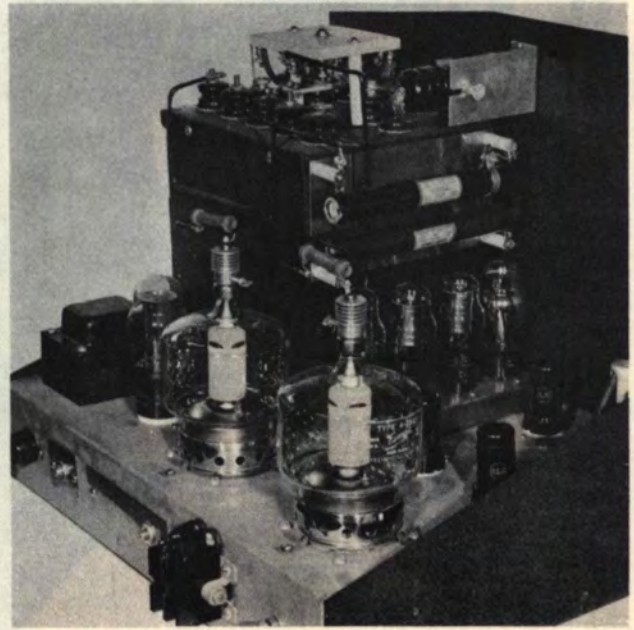

Fig. 7

Experimental 500 watt Class-AB₁ audio amplifier. Designed and built by Eitel-McCullough Laboratories.

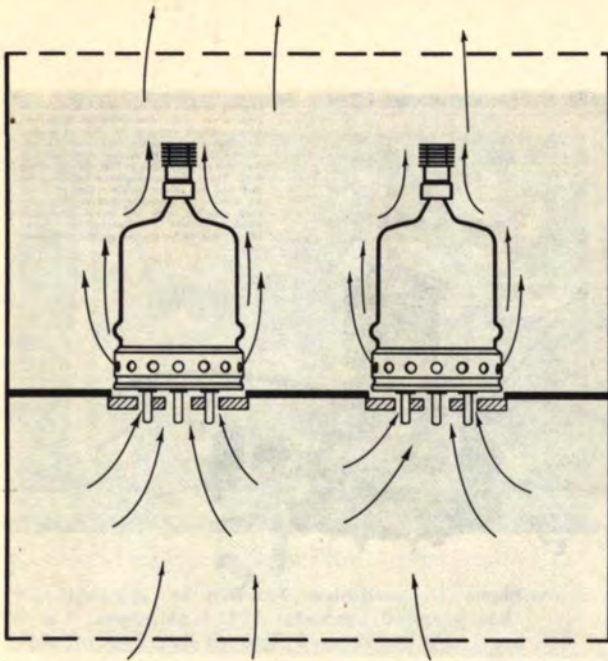

Fig. 8

4-125A mounting providing cooling, shielding and isolation of output and input compartments.

B-1-b. Air Cooling

If the flow of cooling air is upward it will be consistent with the normal flow of convection currents. See Figs. 8 and 9. In all cases the socket is an open structure or has adequate vent holes to allow cooling of the base end of the tube. Cooling air enters through the grid circuit compartment below the socket through a screened opening, passes through the socket cooling the base end of the tube, sweeps upward cooling the

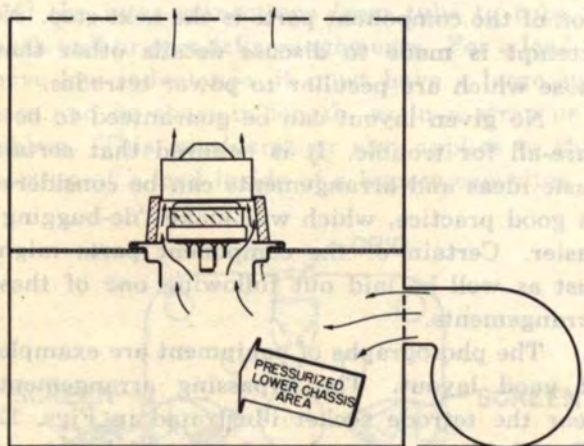

Fig. 9

4X150A chassis mounting providing cooling, shielding and isolation of output and input compartments.

glass envelope and into the output circuit compartment. The output compartment also has a mesh-covered opening which permits the air to vent out readily. These arrangements apply whether the tube is cooled by forced air or convection circulated air. If the tube is to be forced-

air cooled, a suitable fan or blower is used to pressurize the compartment below the tubes. No holes should be provided for the air to pass from the lower to the upper compartment other than the passages through the socket and tube base. Some pressure must be built up to force the proper amount of air through the socket. In the case of convection cooling, open louvers or screened areas permit ready entrance of cool air, and all access holes or vents should have large areas to provide a minimum resistance to the flow of air.

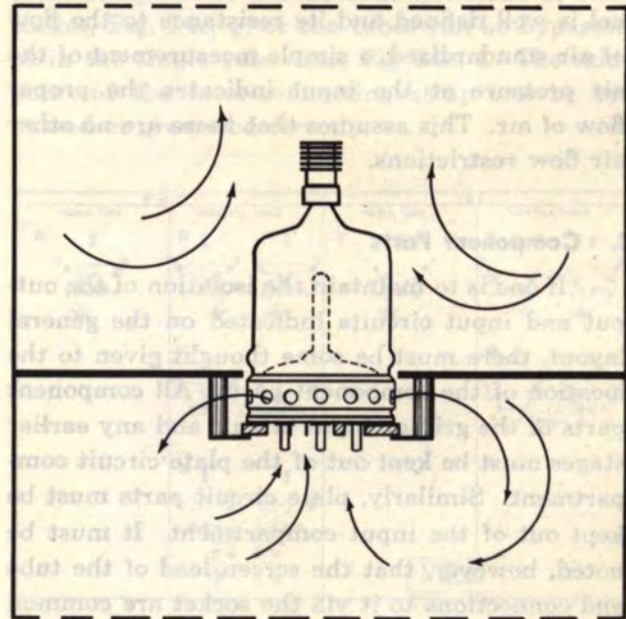

Fig. 10

DO NOT SUB-MOUNT A METAL BASE SHELL TUBE. Base cooling is prevented and no improvement in shielding results.

DO NOT SUB-MOUNT A TUBE WITH METAL BASE SHELL SO THAT THE CHASSIS DECK OR MOUNTING DECK COMES UP ABOVE THE VENT HOLES OF THE BASE SHELL OF THE TUBE. See Fig. 10. No improvement in isolating output and input circuits results, and such an arrangement prevents the flow of cooling air, whether forced or by convection currents. If a tube must be recessed into the mounting deck because of space limitations, a recessing cylinder with wide clearances should be used to permit the air from the base holes to vent into the compartment above deck.

The method shown in Figs. 8 and 9 of supplying the cooling air to the tube has worked successfully, provided the desired flow is obtained, and it is to be preferred over methods which try to force cooling air transversely across the tube base.

SECTION B

In the case of the 4X150A, 4-400A, and 4-1000A tetrodes, there are available complete air system sockets. See Fig. 11. These permit cooling air to be blown axially onto the base of the tube, through or past the base, confined by a suitable chimney to cool the glass portion of the tube, and then forced onto the plate terminal or through the anode cooler. This combined system permits a single stream of air to cool a tube completely in a manner determined to be well balanced by the manufacturer. Since the air channel is well defined and its resistance to the flow of air standardized, a simple measurement of the air pressure at the input indicates the proper flow of air. This assumes that there are no other air flow restrictions.

B-2. Component Parts

If one is to maintain the isolation of the output and input circuits indicated on the general layout, there must be some thought given to the location of the component parts. All component parts of the grid or input circuit and any earlier stages must be kept out of the plate circuit compartment. Similarly, plate circuit parts must be kept out of the input compartment. It must be noted, however, that the screen lead of the tube and connections to it via the socket are common to both the output and input resonant circuits. Due to the plate-screen capacitance of the tube, the r-f plate voltage (developed in the output circuit) causes an r-f current to flow out the screen lead to the chassis. In the case of a push-pull stage, this current may flow from the screen terminal of one tube to the screen terminal of the other tube. Similarly, due to the grid to screen capacitance of the tube, the r-f voltage in the input circuit will cause an r-f current to flow in this same lead to chassis, or to the opposite tube of the push-pull circuit.

Curiously enough, the inductance of this lead, common to both the output and input circuits, has the desirable feature of providing voltage of opposite polarity to neutralize the feedback voltage of the residual plate to control-grid capacitance of the tube. (This is discussed under section D-2 "Neutralization".) It should be noted, however, that the mutual coupling from the screen lead to the input resonant circuit might possibly be a source of trouble if accentuated.

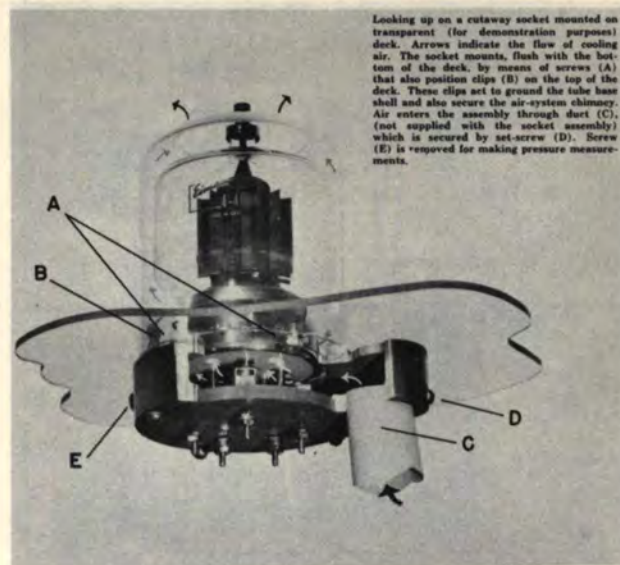

Fig 11

Eimac 4-400A/4000 Air System Socket providing balanced tube cooling by a single stream of air.

Parasitic oscillations are usually unavoidable present in new designs. Such parasitic oscillations result from the minor characteristics of some of the lead wires and circuit components and such incidental circuits must be altered to prevent their occurrence. This is a straight-forward "de-bugging" and will not affect the performance of the fundamental frequency.

Thus, after the general arrangement of the layout of the new amplifier is known, the location of the component parts is the next step. No attempt is made to discuss details other than those which are peculiar to power tetrodes.

No given layout can be guaranteed to be a cure-all for trouble. It is believed that certain basic ideas and arrangements can be considered as good practice, which will make "de-bugging" easier. Certain of the component parts might just as well be laid out following one of these arrangements.

The photographs of equipment are examples of good layout. The bypassing arrangements near the tetrode socket illustrated in Figs. 12, 13 and 14 are examples of successful arrangements. They are not presumed to be perfect nor the only possible good arrangements.

B-3. Lead Lengths

Some of the inter-connecting lead wires close to the tube should be made extremely low inductance to minimize the chances of forming possible VHF parasitic circuits. If two or more tubes are used they should be placed reasonably

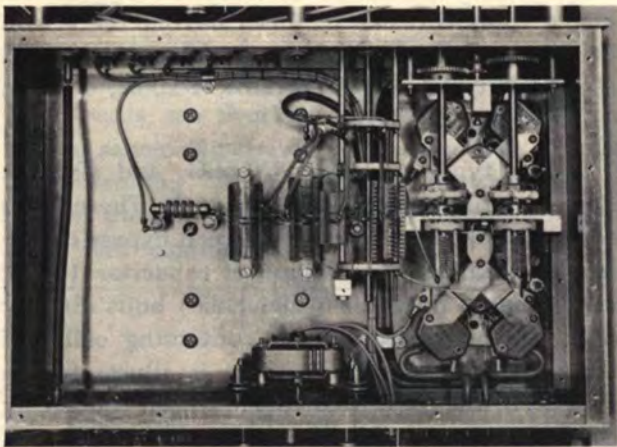

Fig 12

Underside of push-pull multi-band r-f amplifier employing 4-250A tetrodes. Designed and built by C. F. Bane (W6WB)².

close together to help provide short inter-connecting leads. The lead lengths of radio frequency circuits involving the fundamental frequency can usually be much longer and will depend a good deal on the frequency of the fundamental. All of the d-c, keying, modulating, and control circuit wires can be quite long, if properly arranged, and so be kept away from the active r-f circuits.

The following inter-connecting leads in a tetrode power amplifier should preferably have quite low inductance: the filament and screen bypassing leads, the leads from grid and plate to the tuning capacitor of the r-f circuit and return, and the inter-connections from tube to tube in push-pull or parallel arrangements. For a lead to have low inductance, it must have a large surface and be short in length, as in a strap or a ribbon. This consideration also applies to that portion of a lead inside of a bypass capacitor.

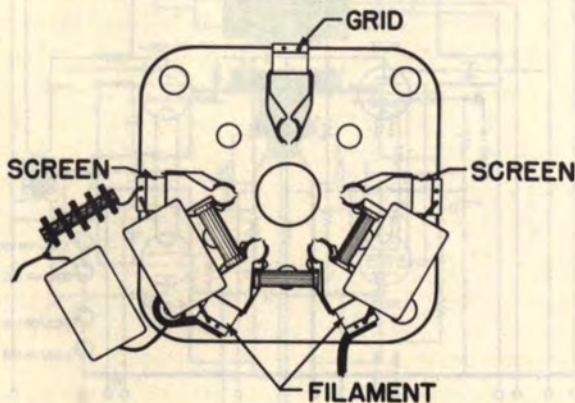

Fig. 13

Typical socket bypassing of screen and filament terminals as used by C. F. Murdock (W6OMC). Note use of parallel low inductance ceramic and larger mica capacitors.

B-4. Filament Bypassing

Low inductance bypass capacitors should be used in bypassing the filament. It is good practice to place one directly between the filament socket terminals. If the circuit allows it, strap one filament directly to the chassis, and if not, use a second bypass capacitor from one terminal to chassis.

If two or more tubes are in a push-pull or parallel circuit, one can use a short strap inter-connecting one of the filament terminals of each socket, Fig. 14c, g; or the tubes can be bypassed as in the single tube case, Fig 14b, f. The midpoint of the inter-connecting strap can be bypassed or grounded directly.

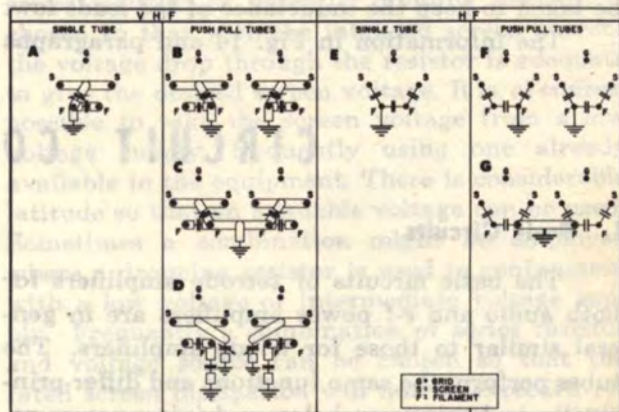

Fig. 14

Various screen and filament bypassing arrangements.

In case separate filament supplies are used, as in individual metering circuits, filament bypasses as shown in Fig. 14d have been found satisfactory.

With tubes having a completely isolating screen cone terminal such as the 4X500A and 4X150A, the general circuit arrangement is usually different. The filament or cathode should go directly or through bypasses to the cavity wall or chassis to which the screen terminal is bypassed. Typical cavities or arrangements are shown in Figs. 5, 6, 9 and 17. In the case of the 4X150A air system socket, the cathode terminals are secured to the mounting cup which also forms one plate of the screen bypass capacitor.

B-5. Screen Bypassing and Screen Series Tuning

Low inductance leads are generally advisable for screen terminal connections. For all frequencies it has been found good practice for the

screen bypass capacitor to go directly from screen to one filament terminal. This applies to tubes in push-pull as well as single tubes. In the VHF region the connection to the screen terminals should be made to the mid-point of a strap placed between the two screen terminals of the socket. This provides for equal division of the r-f current in the two screen leads and minimizes the heating effects.

Above the self neutralizing frequency of the tetrode (about 25 Mc. for the 4-1000A and around 80 Mc. for the 4-125A) the screen bypass capacitors are usually variable capacitors. (See section D-2 "Neutralization"). The variable capacitors are placed in the circuit at the same location as the bypass capacitors. Care should be taken to keep the inductance of the leads low.

The information in Fig. 14 and paragraphs

above apply directly to tubes having the screen grid mounted on internal supporting lead rods, as in the types 4-65A, 4-125A, 4-250A, 4-400A, 4X500F and 4-1000A.

The types 4X150A, 4X150G, and 4X500A have isolating screen cone terminals. These tubes seem to work best when the screen bypass capacitor is a flat sandwich type of capacitor (using silver coated mica for a dielectric) built directly onto the peripheral screen contacting collet of the socket. This arrangement is illustrated in Figs. 5, 6, and 17. Provided the screen contacting collets do not introduce appreciable inductance, it has been found that capacitors having values of about 800 micro-microfarads or greater are suitable for VHF and UHF frequencies. At lower frequencies the usual bypass capacitor values of about .001 to .003 mfd are suitable.

CIRCUIT CONSIDERATIONS

C-1. Basic Circuits

The basic circuits of tetrode amplifiers for both audio and r-f power amplifiers are in general similar to those for triode amplifiers. The tubes perform the same functions and differ principally in having much lower driving power requirements and much greater inherent isolation between output and input circuits. Such differences as exist in the details and associated circuits are discussed in the following paragraphs and sub-sections.

In designing the basic r-f circuits, reference should be made to the technical data sheet of the particular tube type for the electrode voltages and currents, and the output and driving power to be expected.

Because of the ability of the screen to assist in the flow of plate current, the grid can control a large plate current without going positive. For this reason low distortion audio amplifiers in class AB₁ are possible. Thus, the tube requires audio driving voltage only (with no grid current flowing) while delivering large audio power, such as 750 watts from a pair of 4-250A's or 3 kw from a pair of 4-1000A tetrodes. For such a circuit refer to Fig. 15 where a pair of receiving tubes in a resistance coupled, phase inverting circuit is all that is required to drive the tetrode. For a typical equipment design see Atkins & Mandoli¹, and Fig. 7.

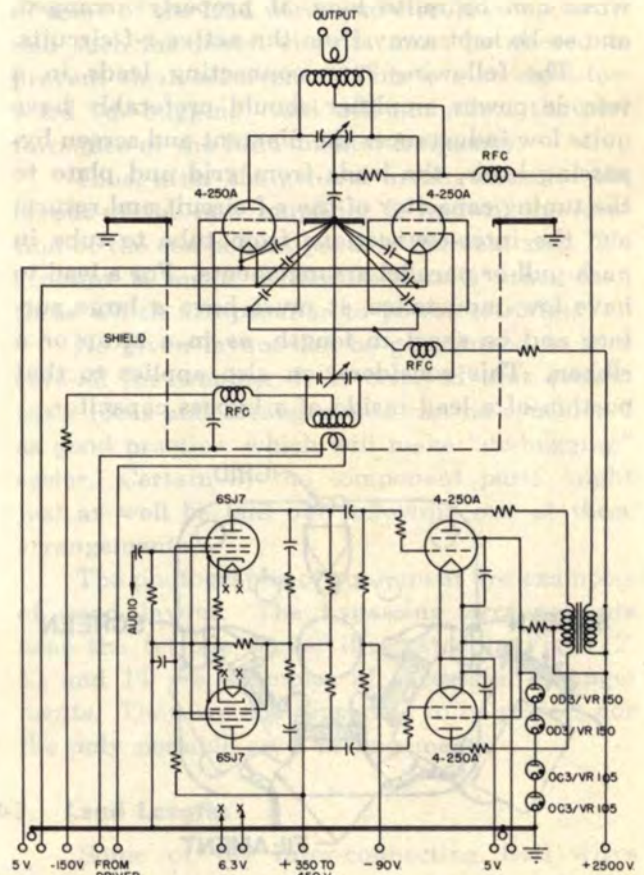

Fig. 15

Typical high-level-modulated r-f amplifier circuit with modulator and driver stages, 1000 watts input.

VHF circuits appear very simple and clean as shown in Figs. 3, 4, and 5. Care in bypassing and neutralizing (if required) is very important. For details see Sections B-4, B-5 and D-2. A typical schematic circuit is shown in Fig. 16. An understanding of transmission line circuits is helpful though no more necessary in tetrode circuits than triode circuits.

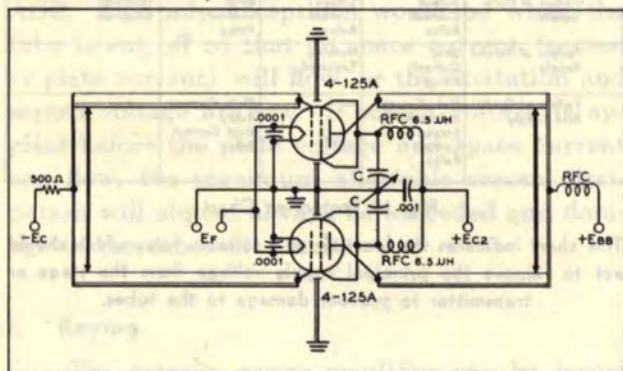

Fig. 16

Screen-tuning neutralization circuit for use above 100 Mc. with 4-125A tetrode.

Some tetrodes are able to operate well into the UHF region, and coaxial type cavity circuits are normally employed. In general, microwave and cavity techniques apply to the cavity construction. As indicated in Fig. 17, screen bypassing is introduced as part of the cavity construction.

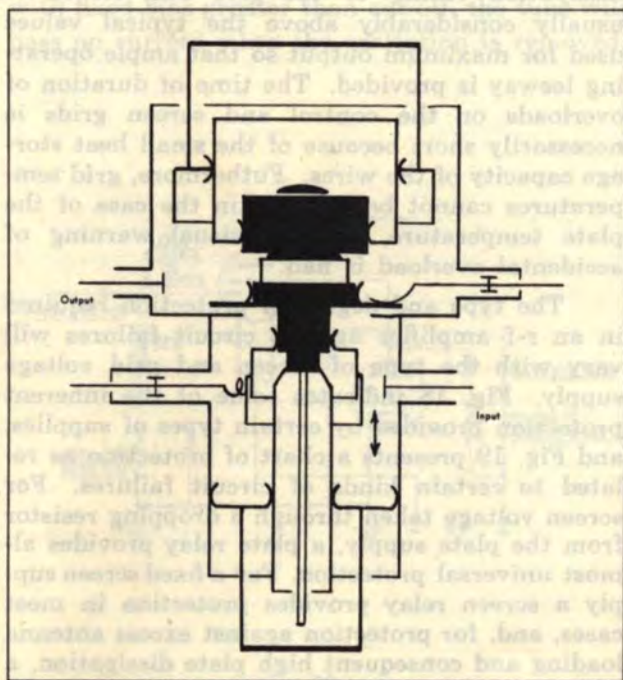

Fig. 17

Schematic cavity section of 1250 Mc., amplifier employing 4X150G tetrode.

C-2. Bypassing, Filtering, Screening

Essentially the requirements for confining the r-f energy to the desired circuits by bypassing, filtering, and screening are the same with tetrode power amplifiers as with triode amplifiers. See section B-1, 4, 5 and D-2 for discussion of best arrangements.

C-3. Power Supply Consideration

In general, power supply problems for the plate and grid are the same as for the triode amplifier. The need for screen voltage introduces some new considerations and provides some new possibilities.

Voltage for the screen grid of a power tetrode can readily be taken from the power supply used for the plate of the tube. In this case a series resistor, or potential dividing resistor, is chosen so that with the intended screen current the voltage drop through the resistor is adequate to give the desired screen voltage. It is, of course, possible to take the screen voltage from a low voltage supply, frequently using one already available in the equipment. There is considerable latitude so that an available voltage can be used. Sometimes a combination might be employed where a dropping resistor is used in conjunction with a low voltage or intermediate voltage supply. Frequently a combination of series resistor and voltage source can be chosen so that the rated screen dissipation will not be exceeded regardless of the variations in screen current. With a fixed screen supply, there are advantages in using an appreciable amount of fixed grid bias so as to provide protection against loss of excitation, or for cases where the driver stage is being keyed.

If the screen voltage is taken through a dropping resistor from the plate supply, there is usually little point in using a fixed grid bias because an unreasonable amount would be required to protect the tube if the excitation failed. When a screen dropping resistor is used, most of the bias is normally supplied through a grid resistor and other means are used for tube protection.

Under operating conditions with normal screen voltage the cut-off bias is low (about 1/5 the screen voltage). When a stage loses excitation and runs statically, the screen current falls close to zero. (See static curves of tube in question.) If the screen voltage is obtained through a simple dropping resistor from the plate supply, the screen voltage will then rise close to full plate voltage. Because the cut-off bias required is proportional to the screen voltage, the grid bias required will be much greater than the amount of bias desired under normal operating conditions. For further discussion see C-4 "Protection" and C-5 "Keying".

If the output power of a transmitter or amplifier stage is to be adjustable by varying the plate voltage, it is advisable to take the screen voltage through a dropping resistor from the plate supply. Then, as the plate supply voltage is raised or lowered, the screen voltage rises or falls also and the plate current will follow. Alternatively, the screen supply could be separate but with large series resistance to give poor regulation, and the changes in screen current would cause the screen voltage to rise or fall. It is necessary to have the plate current proportional to the plate voltage if the same loading adjustment (load resistance) is to serve for all power levels. If the plate current does not follow the plate voltage, the loading would have to be changed for each power level. This added control over the screen voltage is necessary because the plate current in a tetrode is principally controlled by screen voltage when excitation is present, and very little by plate voltage alone.

FIXED SCREEN SUPPLY		SCREEN VOLTAGE THROUGH DROPPING RESISTOR
FIXED GRID BIAS	RESISTOR GRID BIAS	RESISTOR GRID BIAS
All variable grid drive applications, i.e. Audio Amplifiers. Video Amplifiers. Linear R-F Amplifiers. Grid Mod. R-F Amp. Provides protection against loss of excitation, or keyed driver.	Screen Mod. R-F Amp. Reduces effects of excitation variations.	Plate Mod. R-F Amp. Variable loading applications. Power level adjustable by changing plate voltage. Protection can be had for loss of excitation or keyed excitor stage by using the screen voltage control of Fig. 20.

Fig. 18

Applications and circuits to which fixed and resistor type screen and grid supplies are best suited.

In Fig. 18 a chart summarizes some of the reasons for choosing either a fixed screen supply or dropping resistor type of screen supply. Similarly the type of the grid bias is important and should be chosen with both the application and the protection of the tube in mind. The d-c screen and grid currents are sensitive to changes in excitation and loading, and these changes affect the d-c grid and screen voltages if the supplies have appreciable internal resistance. These effects may be very beneficial if properly employed but in some cases are undesirable. For all variable grid drive applications a fixed screen supply and a fixed control grid bias are necessary. It should be noted, however, that for a plate modulated r-f amplifier, an r-f amplifier where a variable loading condition is expected, or where output power is to be controlled by changing plate voltage, a screen source with poor regulation is desirable, i.e., screen voltage obtained through a screen dropping resistor.

CIRCUIT FAILURE	FIXED SCREEN SUPPLY		SCREEN VOLTAGE THROUGH DROPPING RESISTOR	
	FIXED GRID BIAS	RESISTOR GRID BIAS	FIXED GRID BIAS	RESISTOR GRID BIAS
Loss of Excitation	No Protection Required	Plate Current Relay	Plate Current Relay	Plate Current Relay or Screen Control Circuit—Fig. 20
Loss of Antenna Loading	Screen Current Relay	Screen Current Relay	Grid Current Relay	Nothing Required
Excess Antenna Loading	Screen Under-Current Relay	Screen Under-Current Relay	Plate Current Relay	Plate Current Relay
Failure of Plate Supply	Screen Current Relay	Screen Current Relay	Grid Current Relay	Nothing Required
Failure of Screen Supply	Grid Current Relay	Nothing Required	—	—
Failure of Grid Bias Supply	Plate Current Relay or Screen Current Relay	—	Plate Current Relay Grid Current Relay	—

Fig. 19 Protection Chart

This chart indicates the location of a suitable relay which should act to remove the principal supply voltage from the stage or transmitter to prevent damage to the tubes.

C-4. Protection

Eimac tetrodes are designed to stand considerable abuse. For instance, the excess anode dissipation resulting from detuning the plate circuit of the tube will have no ill effects if not applied for periods of time sufficient to overheat the bulb and the seal structure.

Similarly the grid and screen will stand some excess dissipation. In the latter cases, however, the maximum dissipation indicated on the data sheet should not be exceeded except for time intervals of less than a second. The maximum dissipation rating of the grid and screen is usually considerably above the typical values used for maximum output so that ample operating leeway is provided. The time of duration of overloads on the control and screen grids is necessarily short because of the small heat storage capacity of the wires. Furthermore, grid temperatures cannot be seen, as in the case of the plate temperature, and no visual warning of accidental overload is had.

The type and degree of protection required in an r-f amplifier against circuit failures will vary with the type of screen and grid voltage supply. Fig. 18 indicates some of the inherent protection provided by certain types of supplies, and Fig. 19 presents a chart of protection as related to certain kinds of circuit failures. For screen voltage taken through a dropping resistor from the plate supply, a plate relay provides almost universal protection. For a fixed screen supply a screen relay provides protection in most cases, and, for protection against excess antenna loading and consequent high plate dissipation, a screen undercurrent relay should also be used. (Starting up in the latter case will, of course, require a temporary hold-in circuit.)

Plate, screen, and grid bias voltages may be applied simultaneously to a tetrode. Grid bias and excitation can usually be applied alone to the tube, especially if a grid leak resistor is used. Plate voltage can be applied to the tetrode before the screen voltage, with or without excitation to the control grid. NEVER APPLY SCREEN VOLTAGE BEFORE PLATE VOLTAGE. The only exceptions would be when the tube is cut off so that no space current (screen or plate current) will flow, or the excitation and screen voltage are low. If screen voltage is applied before the plate voltage and space current can flow, the maximum allowable screen dissipation will almost always be exceeded and damage to the tube will result.

C-5. Keying

The tetrode power amplifier can be keyed using the same basic principles employed with any power amplifier. In addition, the screen electrode provides another low power circuit where keying can be introduced. Suitable filters, of course, must be used so that the make and break is slow enough to avoid high frequency sidebands known as "key clicks". The usual "key click" filter techniques apply.

There are several good methods of controlling the tetrode r-f power amplifier when exciter keying is used. With the screen voltage fixed and with fixed bias greater than cut-off, the tube will pass no current when the excitation is removed.

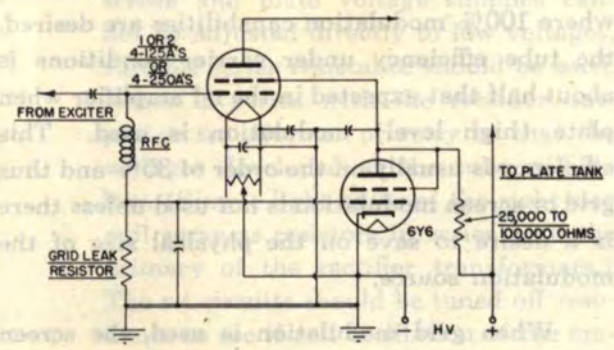

Fig. 20

Screen voltage control circuit for exciter keying or protection against loss of excitation when supplying screen from high voltage source

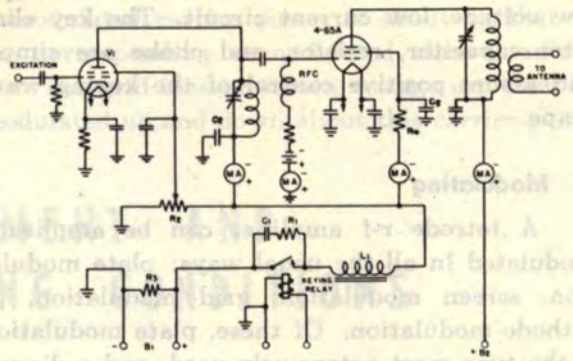

Fig. 21

Tetrode amplifier keying circuit used by B. O. Ballou (W6BET)†.

It is also possible to key the exciter stage when the screen voltage is taken through a dropping resistor and grid leak bias is used. See Fig. 20. In this system a high transconductance, low mu triode is connected between screen and cathode, and the controlling bias for the small triode is taken from the tetrode bias developed in the grid leak resistor. When normal excitation is present on the tetrode r-f amplifier and grid bias is developed, the triode control tube is cut off and the screen voltage circuit operates normally. If excitation voltage is removed from the tetrode power amplifier, the bias voltage developed in the resistor drops to zero and the control triode becomes conducting. The current drawn by the triode control tube will increase the IR drop in the screen dropping resistor and lower the screen voltage to a very low value.

There is still some screen voltage on the tetrode and a small static plate current flows which, however, is usually not enough for the plate dissipation rating to be exceeded. This value can be reduced further by putting a second control triode in parallel with the first (also a smart precaution against failure of the single triode), by putting a gas regulator tube in series with the lead to the screen before the screen r-f bypass capacitor, or by introducing a small amount of fixed bias on the tetrode between the grid resistor and the tetrode grid. These procedures are usually not required. In fact, the static plate current gives a desirable bleeder action for the plate supply.

Fig. 21 shows a method of keying a tetrode r-f power amplifier where the low voltage power supply for the screen of the tetrode and for the plate and screen of the driver stage is

keyed directly. The circuit is described by Ballou^{2, 11}. This permits keying in a relatively low voltage, low current circuit. The key click filter capacitor, resistor, and choke are simple and assure positive control of the keying wave shape.

C-6. Modulating

A tetrode r-f amplifier can be amplitude modulated in all the usual ways: plate modulation, screen modulation, grid modulation, or cathode modulation. Of these, plate modulation is the type most extensively used, and a discussion of several simple methods of obtaining simultaneous modulation of the screen will be helpful in this respect.

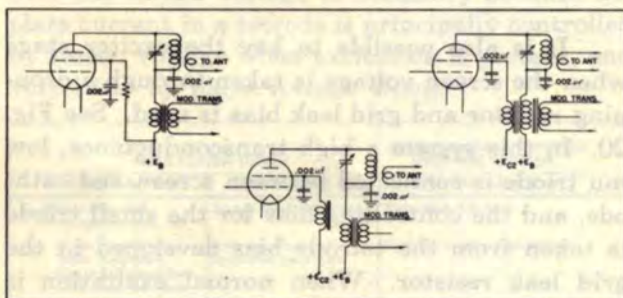

Fig. 22

Basic high-level-modulating circuits for tetrodes.

Fig. 22 shows three of the basic plate modulation (or high level modulating) circuits, and Fig. 15 shows a complete schematic involving a plate modulated r-f amplifier and the audio modulator stage, using a pair of 4-250A tetrodes to modulate a pair of 4-250A tetrodes.

In plate modulation it is necessary to introduce not only amplitude modulation of the plate voltage, but also to develop about 70% amplitude modulation of the screen voltage of the tube as well, for 100% carrier modulation. Modulation of the screen voltage can be developed in one of the following three ways:

1. By supplying the screen voltage through a dropping resistor connected to the unmodulated d-c plate supply.
2. When a low voltage fixed screen supply is used, a modulation choke is placed in series with the supply. In the case of voice modulation this is about a 10 henry choke.
3. A third winding on the modulation transformer designed to develop the required screen modulation voltage.

It is interesting to note that in all three cases the screen of the tetrode tube supplies the necessary audio power. During the portion of the modulation cycle when the plate voltage is increased, the screen current decreases. If the screen is supplied through an impedance such as the screen dropping resistor, or modulation choke, the voltage drop in this series impedance becomes less and the screen voltage rises in the desired manner. On the other part of the modulation cycle when the plate voltage is decreased, the screen current increases causing a greater voltage drop in the screen series impedance, thus lowering the voltage on the screen of the tube.

It will be noted that in the plate circuit as the plate voltage increases, the plate current increases, which requires power to be supplied from the audio modulator. In the screen circuit however, as the screen voltage increases, the screen current decreases. This corresponds to audio power being supplied from the tetrode and d-c screen voltage source, and delivered to the dropping resistor or series impedance. In the case of the modulation transformer the power is supplied back to the audio source. In all cases, this power is a few per cent of the plate power input to the tube and is therefore negligible.

Where modulation voltage appears on an electrode of a tube, the r-f bypass capacitor of this electrode should be kept to about .002 mmfd or less in order to avoid bypassing high modulation frequencies.

In grid modulation or screen modulation, where 100% modulation capabilities are desired, the tube efficiency under carrier conditions is about half that expected in the r-f amplifier when plate (high level) modulation is used. This efficiency is usually on the order of 35% and thus grid or screen modulation is not used unless there is a desire to save on the physical size of the modulation source.

When grid modulation is used, the screen voltage and grid bias must be taken from sources with good regulation. This usually means a separate low voltage power supply source. In the case of screen modulation, the grid bias should be taken from a grid leak bias resistor. The procedure in screen modulation is otherwise similar

to the standard procedure of modulating with an electrode other than the plate. The r-f amplifier is adjusted to good class-C operating conditions, and then the grid bias is increased, or the screen voltage is reduced, until the output antenna current falls to half its former value. This gives a

carrier condition which will permit 100% amplitude modulation. Under these conditions the unmodulated carrier power is about $\frac{1}{3}$ that of the corresponding unmodulated class-C amplifier. The grid bias or screen voltage can then be modulated up and down about this carrier point.

CIRCUIT ADJUSTMENT AND CHOICE OF OPERATING CONDITIONS

D-1 Stabilizing the Amplifier

At this point it is assumed that the amplifier has been built, supply and control circuits tested out, the filament voltage checked at the tube sockets, air cooling is correct, and the grid and plate circuits resonate at the desired frequency. The next step is to apply voltage to the amplifier and test for stability.

D-1-a. Testing for Parasitic Oscillations

In the case of the tetrode r-f power amplifier, it will be necessary to investigate not only for the possibility of self oscillation, but lack of feedback on the fundamental frequency. The basic steps of checking for self oscillation are three fold:

1. The amplifier should be operated without r-f excitation and without fixed grid bias, with light loading and with low voltages applied to the screen and plate. The voltage should be high enough to develop full plate dissipation, however. For this test grid leak bias should be used. If the screen and plate voltage supplies cannot be adjusted directly to low voltages, suitable series resistance should be used, either in series with the rectifier output or transformer primary so that the voltages developed at the tube will be low. (Simple light bulbs of the right size will serve as resistors in series with the primary of the rectifier transformers.) The r-f circuits should be tuned off resonance to see if self oscillation of the amplifier can be started. The presence of any current on the grid milliammeter means that self oscillation is present.
2. By means of a wave meter the frequency of self oscillation of the r-f power amplifier is found.

3. The circuit supporting the self oscillation must be determined and altered so that such oscillations cannot exist, and without disturbing the performance on the normal frequency of the amplifier.

The subject of parasitic oscillations in amplifiers has been well covered in the literature, and the following references will be helpful: Mix³, Fyler⁴, Bane⁵.

D-1-b. Correction of Parasitic Oscillation

The usual self oscillations in r-f power amplifiers have been found to fall in the following three classes:

1. Oscillation at a VHF frequency from about 40 to 150 Mc., regardless of the normal frequency of the amplifier.
2. Self oscillation on the fundamental frequency of the amplifier.
3. Oscillation at a low radio frequency below the normal frequency of the amplifier.

The low frequency oscillation in an amplifier usually involves the r-f chokes, especially when chokes are used in both the output and input circuits. Because the possible feedback coupling in a tetrode is negligible at such low frequencies, this type of oscillation due to feedback through the tube is generally not found in the tetrodes under discussion.

Oscillation near the fundamental frequency, if it occurs, involves the normal resonant circuits, and brings up the question of neutralizing the r-f power amplifier. This general subject is discussed thoroughly under "Neutralization" section D-2.

In case a parasitic self oscillation is found on a very high frequency, the inter-connecting leads of the tube, the tuning capacitor and by pass capacitors are involved. This type of oscillation does not usually occur when the power amplifier is designed for operation in the VHF region

and where the r-f circuits external to the tube have negligibly small tuning capacitors. Without tuning capacitors the highest-frequency oscillating circuit possible is then the fundamental and there would be no higher frequency circuit available for the parasitic. (The only exception would be where higher order modes of line circuits might provide a parasitic circuit. However, little trouble has been found in this respect.)

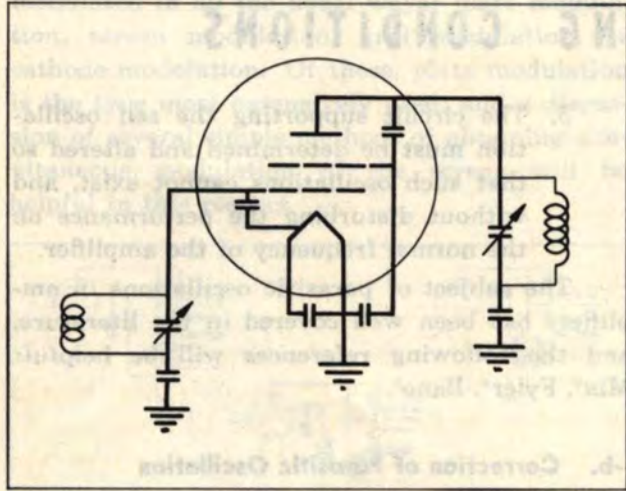

Fig. 23

Usual circuit supporting VHF parasitic oscillation in HF r-f amplifiers.

The VHF oscillation occurs commonly in amplifier constructions where the radio frequency circuits are composed of coils and capacitors, as in the HF and LF region. As will be seen in Fig. 23, the parasitic oscillation uses the capacitors of the fundamental resonant circuit as bypass capacitors, and the associated grid and plate leads for the inductances of the parasitic circuit. The tube capacitances help form the tuned-plate tuned-grid oscillation circuits. The circuit is indicated by the heavy lines in Fig. 23.

There are several straight-forward ways to suppress the VHF parasitic oscillation. In general, it will probably be more easily suppressed if the general layout and bypassing methods indicated earlier are followed.

It turns out that the frequency usually met in a VHF parasitic oscillation is well above the self neutralizing frequency of the tube. (See D-2-b "Analysis of Neutralizing Circuits".) However, if the self neutralizing frequency of the tube can be increased and the frequency of the parasitic lowered, complete suppression of the parasitic may result, or its suppression by resistor-coil parasitic suppressors made easier.

The following table lists the usual frequency around which the VHF parasitic may occur with usual circuit lead lengths:

4-1000A	90-110-Mc.
4X500F	130-145 Mc.
4X500A	Approx. 225 Mc.
4-400A	130-150 Mc.
4-250A	130-150 Mc.
4-125A	130-145 Mc.
4-65A	130-170 Mc.

It is also possible to predict fairly closely with a grid dip wavemeter the frequency to be expected in a given equipment. The circuit should be complete and no voltages on the tube. The grid terminal may be strapped to the filament or screen because the grid circuit does not usually seem to be involved. Couple the meter to the plate or screen lead.

The following two methods of eliminating the VHF parasitic oscillation have been used successfully:

1. By placing a small coil and resistor combination in the plate lead between the plate of the tube and the tank circuit. See Fig. 24. The resistor-coil combination is usually made up of a non-inductive resistor of about 50 to 100 ohms, shunted by 3 or 4 turns about 1/2" in diameter and frequently wound right around the resistor. In some cases it may be necessary to use such a suppressor in both the plate and grid leads. The resistor coil combination operates on the principle that the resistor loads the VHF circuit but is shunted by the coil for the lower fundamental frequency.

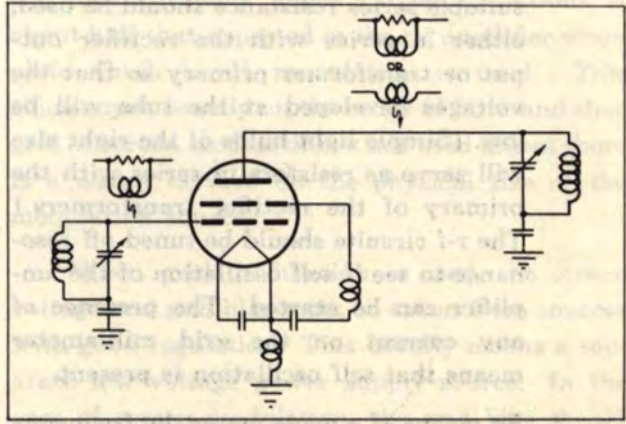

Fig. 24

Placement of parasitic suppressors to eliminate VHF parasitic oscillations in HF r-f amplifiers.

2. By the use of small parasitic chokes in the plate lead. See Fig. 24. The size of this coil will vary considerably depending upon the tube and the circuit layout, and may run from about 4 to 10 turns of about a $\frac{1}{2}$ " diameter. Apparently, the presence of this choke in the frequency determining part of the circuit lowers the frequency of a possible VHF parasitic so that it falls near the self neutralizing frequency of the tube and bypass leads. (See D-2-b "Analysis of Neutralizing Circuits.") In addition to varying the size of the suppressor choke, the amount of inductance common to the screen and filament in the filament grounding strap may be a factor. This can be varied simultaneously with the suppressor choke.

Of the two methods indicated above for suppressing VHF parasitic oscillations, the first one is probably the simpler to use and has been widely employed. No detailed study has been made of the circuits involved in the second method, but the method has been used successfully as indicated by Mix³ and Bane⁵. A further discussion of the theory believed active in the second case is given under section D-2 "Neutralization".

The procedure of checking for self oscillation in an r-f power amplifier described above in section D-1 will normally show up most trouble and allow for its correction. If, however, the correction is marginal it may sometimes happen that under operating conditions the self oscillation will be triggered off. The oscillation may occur only on the peaks of amplitude modulation or on keying surges. By observing the r-f envelope on a cathode ray oscilloscope, the oscillation can usually be seen. The trouble can be fully eliminated by pursuing further the corrective procedures outlined under D-1-b above.

A more difficult self oscillation to locate is one occurring on a harmonic of the fundamental frequency and occurring only when the stage is operating. It will show up when testing for the presence of abnormal power in the harmonics under operating conditions.

In the case of an audio amplifier employing tetrodes, small non-inductive resistors of about 100 ohms resistance should be placed in series with the plate, and possibly the grid as well, in case self oscillation of the amplifier occurs in the very high frequency portion of the r-f spectrum. Should the audio or d-c voltage drop in the resistor be objectionable, it can be shunted with a small coil.

D-2. Neutralization

Whether or not a tetrode should be neutralized seems to be an open question. As stated previously, the feedback within tetrodes is a very small fraction of the feedback present in triodes. In a great many cases the isolation provided by a tetrode is enough so that there is no need to use any neutralization to counteract the negligible feedback. This applies to all low frequency r-f amplifiers. Whether or not neutralization should be used in the HF, the VHF and UHF regions depends entirely upon the particular tube type, the operating conditions and the desired isolation of output and input circuits. In the case of tubes having isolating screen cone terminals, as for instance the 4X150A and 4X150G, no neutralization has been found necessary up through their highest useful amplifier frequency, approximately 500 Mc. and 1000 Mc. respectively. In the case of the 4X500A, also employing the isolating screen cone terminal, it is occasionally found desirable to use neutralization at 100 Mc., though this is frequently not necessary. In the case of tetrodes having internal screen support lead rods, such as the 4-125A and 4-250A types, the need to employ neutralization in the HF region may be found in amplifiers operating with high power gain and high plate voltages, if complete isolation of output and input circuits is desired. Frequently it is not necessary.

At frequencies below the VHF region, neutralization usually employs a capacitance bridge circuit to balance out the feedback due to the residual plate to grid capacitance. This assumes that the screen is well bypassed to ground and so provides the expected screening action. In the VHF and UHF regions the screen is not necessarily at r-f ground potential and the neutralizing circuit becomes more involved. For suitable VHF circuits and simple explanation, see Section D-2-b "Analysis of Neutralizing Circuits".

SECTION D

If neutralization on the fundamental frequency below the VHF region is found desirable, normal cross-neutralization of push-pull amplifiers is simplest. The neutralizing capacitors are small and each capacitor need only be a wire connected to each side of the grid circuit, brought through the chassis deck, and allowed to "look" at the plate of the tube on the opposite half of the circuit. This is illustrated in Fig. 2. The wire or rod can be $\frac{1}{2}$ " to 1" away from the glass, and by adjusting its length or spacing the last trace of coupling can be eliminated from the amplifier. A simple insulating collet mounted on the chassis deck will support the wire or rod and allow it to be adjusted.

In the case of a single-ended stage, either a push-pull output or a push-pull input circuit can be used to provide the out-of-phase voltage necessary for neutralization. Because of the low voltage and the small size of the r-f input circuit, it is usually simpler to make the input circuit push-pull, and the circuit becomes a "grid neutralization" circuit. See Fig. 25. The neutralizing capacitor, C_n , is again very small and similar to those described above under cross-neutralization. To maintain the balance of the input circuit while tuning, it is desirable to have a padding capacitor, C_i , equal in size to the input capacitance of the tetrode.

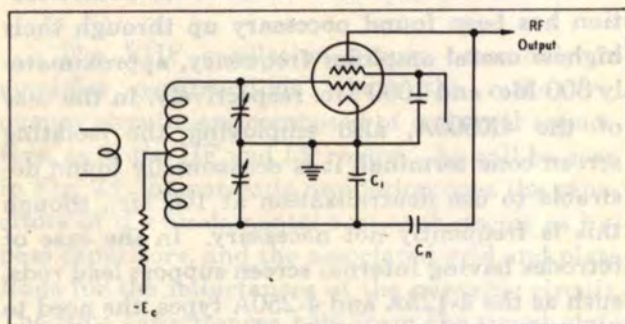

Fig. 25

Push-pull grid neutralization, basic circuit.

Single-ended r-f stages can also be easily grid-neutralized without using a conventional push-pull input circuit. See Fig. 26. In this method described by Bruene⁶, the input resonant circuit is taken off ground a small amount by making the input circuit bypass capacitor, C , somewhat smaller than usual. The voltage to ground across capacitor, C , is out of phase with the grid voltage and can be fed back to plate to provide neutralization. In this case the neutralizing capacitor, C_n , is considerably larger than the capacitance plate to grid and is about the size of those used for neutralizing triodes.

The basic circuit of the Bruene method is shown in Fig. 26a. It can be redrawn as a capaci-

tance bridge showing clearly the grid neutralization circuit. See Fig. 26b. Balance is had when
$$\frac{C_n}{C} = \frac{C_{gp}}{C_{gf}}$$
 where C_{gp} is the feedback capacitance grid to plate of the tetrode, and C_{gf} is the total input capacitance, including tube and stray capacitance.

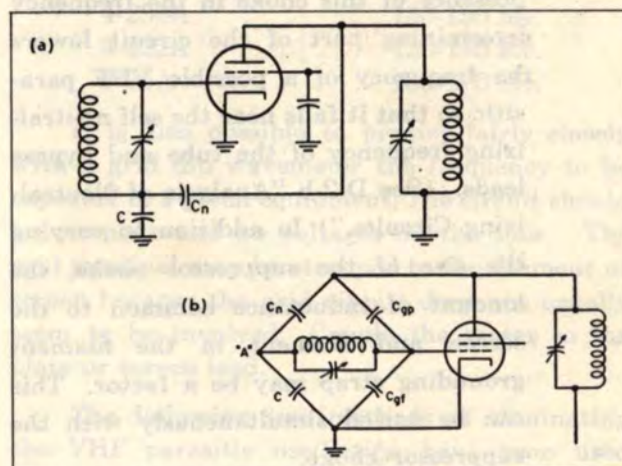

Fig. 26

Single-ended grid neutralization described by Bruene⁶.

a) Basic Circuit. b) Arranged as capacitance bridge.

Single-ended amplifiers can also be neutralized by taking the plate circuit a small amount off ground as was done in the single-ended grid neutralizing scheme, and by using the tube capacitances as part of the bridge circuit. This method has been described by Hultberg⁷.

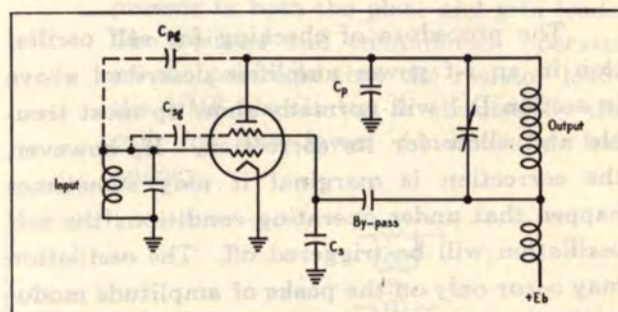

Fig. 27

Single-ended plate neutralization, basic circuit. See Hultberg⁷.

Such a circuit is shown in Fig. 27. It differs from the usual r-f amplifier circuit in that the plate bypass capacitor is returned to the screen side of the screen bypass capacitor, C_s , and in adding stray capacitance from plate to ground, C_p . The size of screen bypass capacitor, C_s , and the amount of stray capacitance in C_p are chosen to balance out the voltages induced in the input

circuit by the internal tube capacitances plate to grid, C_{pg} , and screen to grid, C_{sg} .

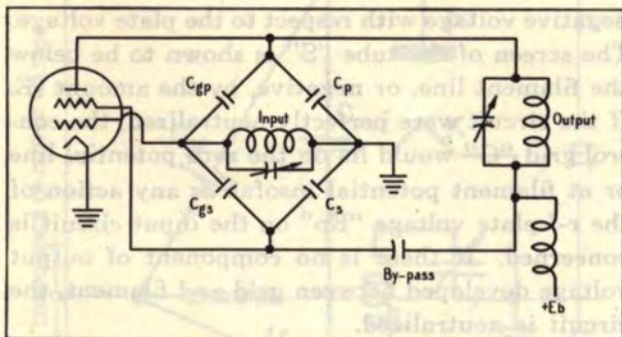

Fig. 28

Single-ended plate neutralization showing capacitance bridge circuit present.

The circuit is redrawn in Fig. 28 in the usual bridge circuit form. Balance is had when $\frac{C_p}{C_s} = \frac{C_{gp}}{C_{gs}}$.

In usual tetrode structures the capacitance from screen to grid is roughly half the published tube input capacitance. (The tube input capacitance is mainly the sum of the capacitance of the grid to screen and the capacitance grid to cathode. Since as a first guess these two capacitances are roughly equal, one is not far off in using half the listed tube input capacitance.)

It should be noted that in all neutralizing capacitance bridge circuits it is assumed that the frequency is low enough so that inductances in the connecting leads and tube structures can be neglected. This is usually not the case in the VHF region, especially in single-ended tetrode stages where bridge circuits balance with a very small voltage in part of the bridge circuit. At VHF the small amount of voltage developed in the residual inductance of the screen circuit can be enough to accomplish neutralization in itself. See section D-2-b "Analysis of Neutralizing Circuits."

D-2-a. Procedure

The neutralizing process for tetrodes follows the standard procedure. The first step in rough adjustment is to break the d-c connections of the plate voltage and screen voltage leaving the r-f circuits intact. (If the d-c current path is not broken, some current is found to flow in either one of these circuits even though their voltages are zero, and the presence of this current causes the amplifier to work in the normal

manner, generating r-f power in the plate circuit. It will then be incorrect to adjust for zero power in the plate circuit.)

As an indicator of neutralization adjustment, one can use either a sensitive r-f meter coupled to the plate circuit or observe the reaction on the grid current as the plate circuit is tuned. When the plate circuit is tuned through resonance, the grid current will dip when the circuit is out of neutralization in the same manner as it does with triode neutralization adjustments. The neutralizing circuit is adjusted until the indication has been reduced to a minimum.

For the final trimming of the neutralization adjustment, the stage should be returned to operating condition at reduced power similar to that used when testing for parasitic oscillations, or under the final loaded operating conditions. At the higher frequencies and in the VHF region, it will be found that a small additional trimming adjustment of the neutralizing circuit is usually required. When the plate circuit is tuned through resonance, the minimum plate current and maximum control grid current should occur simultaneously. The d-c screen current should be maximum at the same time.

The neutralizing procedures indicated above apply not only to the HF radio frequencies, but also apply in the VHF or UHF regions. In the latter cases the neutralizing circuit is different and the conventional cross-neutralization schemes will not be applicable. See below.

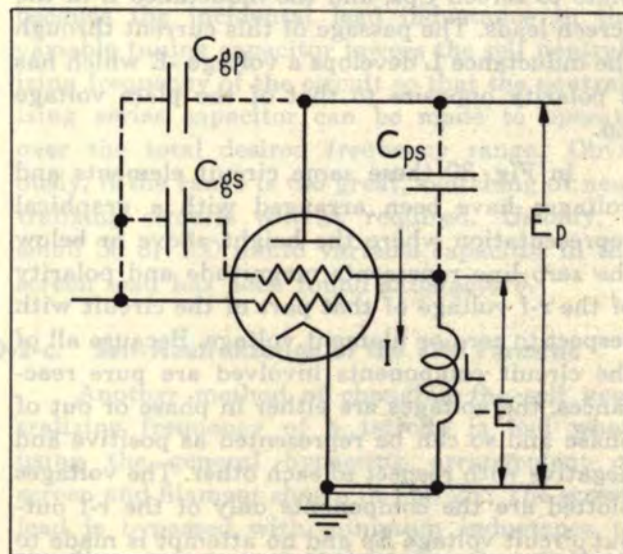

Fig 29

Tetrode characteristics involved in feedback circuit.

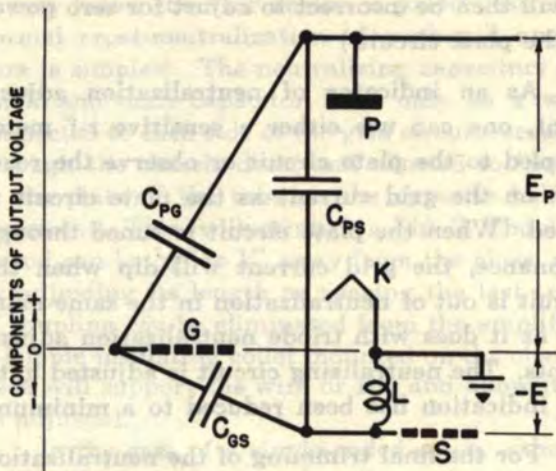

Fig. 30

Graphical presentation of components of output circuit voltages in tetrode when self neutralized.

D-2-b. Analysis of Neutralizing Circuits

Careful analysis of the feedback circuits of tetrodes in the VHF region has been made⁸ and the basic concepts follow. In Fig. 29 the tetrode circuit elements involved in the feedback circuits are indicated. These circuit elements are inherent and inside the vacuum enclosure of the tube, and involve the residual capacitance plate-to-grid, the capacitance from plate to screen, the capacitance from screen to grid, and the inductance of the screen lead to the tube. It will be noted that the r-f voltage developed in the plate circuit E_p causes a current I to flow through the plate to screen C_{ps} , and the inductance L in the screen leads. The passage of this current through the inductance L develops a voltage $-E$ which has a polarity opposite to that of the plate voltage E_p .

In Fig. 30 these same circuit elements and voltages have been arranged with a graphical representation where the height above or below the zero line represents magnitude and polarity of the r-f voltage of that part of the circuit with respect to zero or filament voltage. Because all of the circuit components involved are pure reactances, the voltages are either in phase or out of phase and so can be represented as positive and negative with respect to each other. The voltages plotted are the components only of the r-f output circuit voltage E_p and no attempt is made to show the normal driving voltage on the grid. The plate "P" is shown at a high positive potential above zero and the magnitude is represented by

the distance above the zero line as shown by the dimension E_p . The voltage developed in the screen lead inductance places the screen at a negative voltage with respect to the plate voltage. The screen of the tube "S" is shown to be below the filament line, or negative, by the amount $-E$. If the circuit were perfectly neutralized, the control grid "G" would lie on the zero potential line or at filament potential insofar as any action of the r-f plate voltage " E_p " on the input circuit is concerned. If there is no component of output voltage developed between grid and filament, the circuit is neutralized.

The total r-f voltage between plate and screen comprises plate voltage E_p and screen lead inductance voltage $-E$. This total voltage is applied across a potential divider consisting of the capacitance plate to grid, C_{pg} , in series with the capacitance grid to screen, C_{gs} . When this potential divider is suitably matched to the magnitudes of the voltage E_p and screen lead voltage $-E$, the control grid will have no voltage difference to filament as a result of the output circuit voltage E_p .

It should be noted in Fig. 30 that the potential dividing action between capacitances plate-to-grid, C_{pg} , and grid-to-screen, C_{gs} , will not be affected by the operating frequency. It should be noted also that the division of voltage between plate and screen and screen and ground due to the charging current, I , will vary greatly with frequency. There will, therefore, be some particular frequency at which this potential dividing circuit places the grid at filament potential as far as the plate circuit action is concerned, and this is called the *self neutralizing frequency* of the tetrode. At this particular frequency the tetrode is inherently neutralized due to the circuit elements within the tube structure and any external added screen lead inductance to ground. Typical self neutralizing frequencies with normal screen by-passing circuits are as follows:

Approximate Self Neutralizing Frequencies of Tetrodes

4-1000A	25 to 30 Mc.
4-400A	45 Mc.
4-250A	45 Mc.
4X500F	75 to 90 Mc.
4-125A	75 to 90 Mc.
4-65A	80 to 120 Mc.
4X150A	} apparently above the useful range of the tube.
4X150G	
4X500A	

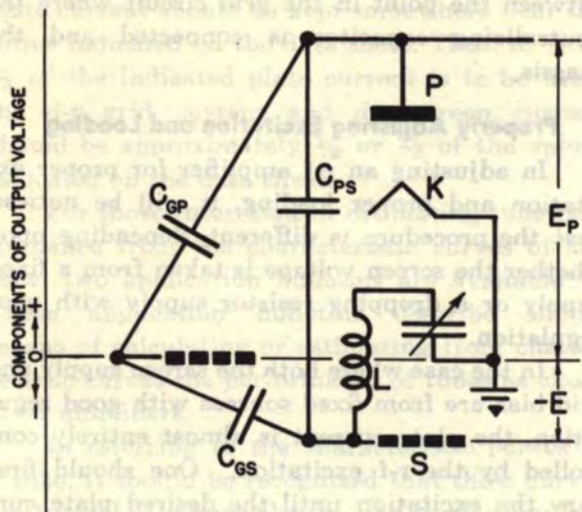

Fig. 31

Components of output voltage of a tetrode when neutralized by added series screen-lead capacitance.

When the tube is operated below the self neutralizing frequency, the normal cross neutralizing circuits apply. In this case a neutralizing capacitor approximately equal to the plate grid capacitance of the tube brings voltage of opposite polarity from the output circuit to the grid or from the input circuit to the plate.

If the operating frequency is higher than the self neutralizing frequency of the tetrode, the voltage $-E$ developed in the screen grid lead inductance is too large to give the proper voltage division between the internal capacitances of the tube. One obvious method of reducing the voltage in the screen lead reactance is to series tune the screen lead to ground so as to lower the total reactance. This takes the form of a series variable capacitor as shown in the graphical representation in Fig. 31.

Another method would be to change the potential divider network made up of the tube capacitances. This could be done by adding capacitance external to the tube between grid and plate. The method is shown in Fig. 32. This added capacitance plate-to-grid is on the same order of size as the residual grid plate capacitance of the tetrode and hence is similar in construction to the neutralizing capacitance used at lower frequency. However, in this case the small wire or rod standing up beside the tube "looking" at the plate (and so forming a neutral-

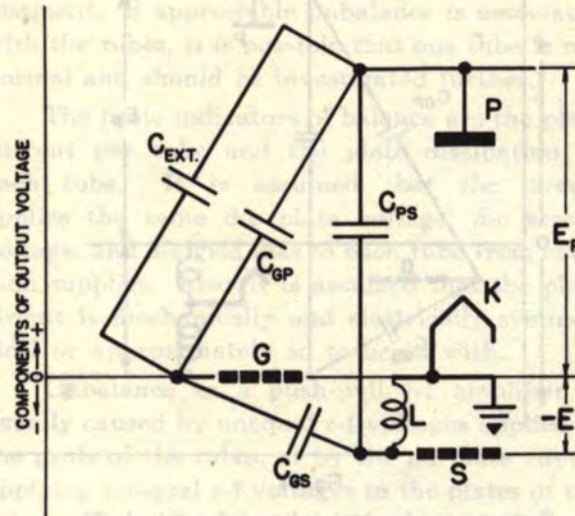

Fig. 32

Components of output voltage of a tetrode when neutralized by added external grid-to-plate capacitance.

izing capacitor) is connected to the grid of the tube rather than to an opposite polarity in the input circuit.

If the r-f power amplifier, operating above the self neutralizing frequency of the tube, must tune over a range of frequencies, it is probably easier to use the screen series tuning capacitor method and make this control available to the operator. If operation is desired over a range of frequencies including the self neutralizing frequency of the tube, this circuit is also desirable because the incidental lead inductance in the variable tuning capacitor lowers the self neutralizing frequency of the circuit so that the neutralizing series capacitor can be made to operate over the total desired frequency range. Obviously, if the range is too great, switching of neutralizing circuits will be required. Usually, a small 50 or 100 mmfd variable capacitor in the screen lead has been found satisfactory.

D-2-c. Self-Neutralization of the VHF Parasitic

Another method of changing the self neutralizing frequency of a tetrode is had when using the general bypassing arrangement of screen and filament shown in Fig. 23. The screen lead is bypassed with minimum inductance to the filament terminal of the tube. Some inductance is introduced in the common filament and screen grounding lead.

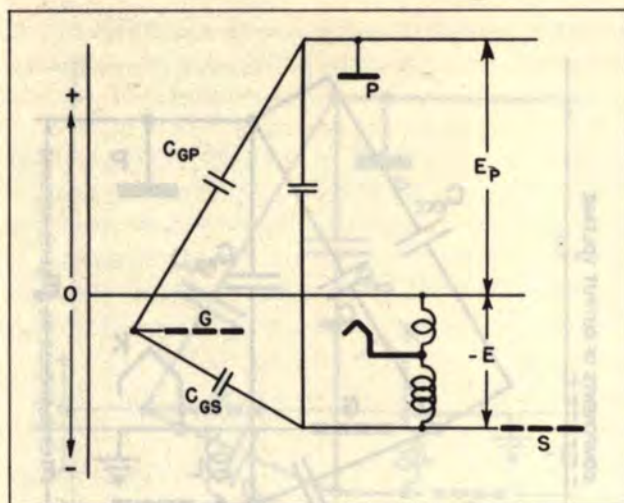

Fig. 33

Components of output voltage of a tetrode neutralized by adding inductance common to screen and cathode return.

The circuit arrangement is plotted with components of plate voltage in Fig. 33. The grid is shown below the zero voltage or chassis potential, indicating that the voltage developed in the total screen lead inductance to chassis is excessive. If now the filament is tapped up on this inductance, a point can be found where the voltage difference between grid and filament is zero as far as the components of plate voltage are concerned. The arrangement will be found to self neutralize at a higher frequency than if the filament and screen were separately bypassed to chassis.

It has been found in tubes, such as the 4-65A, 4-125A, 4-250A, 4-400A and 4-1000A, that the usual VHF parasitic is higher in frequency than the normal self neutralizing frequency of the tube. Thus, by increasing the self neutralizing frequency of the tube and screen bypass arrangement, the tendency of the VHF parasitic to occur is reduced.

If now the frequency of the VHF parasitic is reduced by increasing the inductance of the plate lead (presuming this is the principle frequency defining circuit), it can be made to approach the self neutralizing frequency of the tube and so suppress the parasitic.

It is interesting to note that the later addition of cross-neutralization for the fundamental HF or LF frequency should not disturb this VHF neutralization provided the fundamental neutralizing circuit involves only voltages of the lower or fundamental frequency.

In its purest form this might mean having

zero impedance for the VHF parasitic frequency between the point in the grid circuit where the neutralizing capacitor is connected and the chassis.

D-3. Properly Adjusting Excitation and Loading

In adjusting an r-f amplifier for proper excitation and proper loading, it will be noticed that the procedure is different, depending upon whether the screen voltage is taken from a fixed supply or a dropping resistor supply with poor regulation.

In the case where both the screen supply and grid bias are from fixed sources with good regulation, the plate current is almost entirely controlled by the r-f excitation. One should first vary the excitation until the desired plate current flows. The loading is then varied until the maximum power output is obtained. Following these adjustments the excitation is then trimmed along with the loading until the desired control grid, and screen grid currents are had.

In the case of an r-f amplifier where both the screen and grid bias are taken from sources with poor regulation, the stage will handle very much like the triode r-f power amplifier. The plate current will be adjusted principally by varying the loading, and the excitation will be trimmed to give the desired control grid current. In this case the screen current will be almost entirely set by the choice of the dropping resistor. It will be found that excitation and loading will vary the screen voltage considerably and these should be trimmed to give about the normal screen voltage.

D-4. Operating Voltages and Currents for Various Applications

Probably the simplest way to get an idea of the capabilities of the tube, and the voltages and currents to be used on the various electrodes, is to refer to the technical data sheet for that tube type. A number of typical operating conditions are given for various classes of service. A great many other operating conditions are possible, but these particular ones are usually selected to show the maximum capabilities of the tube for different plate voltages. At no time should the maximum ratings for that class of service be exceeded.

As long as none of the maximum ratings of the tube are exceeded, a wide choice of voltages on the plate, screen, or grid, and a wide range of plate current values is available. In general it will be found that for efficient operation the

ratios of d-c grid current, d-c screen current, d-c plate current should be kept somewhere near the ratios indicated on the data sheet. Thus, if $\frac{1}{2}$ or $\frac{2}{3}$ of the indicated plate current is to be used, the d-c grid current and d-c screen current should be approximately $\frac{1}{2}$ or $\frac{2}{3}$ of the values indicated on the data sheet.

For those interested in estimating tube performance from the characteristic curves of the tube, two application bulletins are available^{9 10}. These application bulletins describe simple means of calculating or estimating from characteristic curves the performance of tubes as class-C r-f amplifiers.

In referring to the characteristic curves of a tube, it should be recognized that these curves are typical of a normal tube. As in all manufactured products, some tolerance is allowed. In general, the currents indicated will be within plus or minus 10% of the values shown.

D-5. Effect of Different Screen Voltages

Typical operating values for a tetrode for a particular value of screen voltage are given on the published data sheet. The screen voltage is not critical and the value used has been chosen as a convenient value consistent with low driving power and reasonable screen dissipation. If lower values of screen voltage are used, more driving power will be required on the grid to obtain the same plate current. If higher values of screen voltage are used less driving power will be required. Thus, high power gain can be had provided the circuit has adequate stability. Care should be observed that the screen dissipation limit is not exceeded. The value of screen voltage can be chosen to suit available power supplies or amplifier conditions.

For a method of altering the coordinate and curve scales of the tube curves to obtain a set of curves for another screen voltage, see page 5 of the Eimac 4-65A Technical Data Sheet¹¹.

D-6. Balance of Push-Pull Amplifiers

In a push-pull r-f amplifier lack of balance of plate circuit or plate dissipation is usually due to lack of symmetry in the r-f circuit. Normally, the tetrodes are similar enough that such unbalance is not associated with the tube and its characteristics. This point can readily be checked by interchanging the tubes in the sockets (provided both tubes have the d-c voltages to plate, screen, and grid in common) and seeing whether the unbalanced condition remains with the socket location or moves with the tubes. If it remains

with the socket location, the circuit requires adjustment. If appreciable unbalance is associated with the tubes, it is possible that one tube is not normal and should be investigated further.

The basic indicators of balance are the plate current per tube and the plate dissipation of each tube. It is assumed that the circuit applies the same d-c plate voltage, d-c screen voltage, and d-c grid bias to each tube from common supplies. Also, it is assumed that the plate circuit is mechanically and electrically symmetrical or approximately so to begin with.

Unbalance in a push-pull r-f amplifier is usually caused by unequal r-f voltages applied to the grids of the tubes, or by the r-f plate circuit applying unequal r-f voltages to the plates of the tubes. The r-f grid excitation should first be balanced until equal d-c plate currents flow in each tube. Then the r-f plate circuit should be balanced until equal plate dissipation appears on each tube.

The balance of plate current is a more important criterion than equality of screen current or grid current. This results from the fact that tubes are more uniform in the plate current characteristics, and also that the screen current is very sensitive to lack of voltage balance in the r-f plate circuit.

Once the d-c plate currents per tube have been made equal by adjusting the r-f grid circuit, the r-f plate circuit can be adjusted to give equal plate dissipations, as noted. Or, if the tubes have equal screen current characteristics, the r-f plate circuit could be balanced until equal screen currents result. If the tubes differ somewhat in screen current characteristics, and the circuit has common d-c supply voltages, the final trimming of the plate circuit balance could be made by interchanging tubes and adjusting the circuit to give the same screen current for each tube regardless of its location.

It should be noted that the d-c grid current has not been used as an indicator of balance of the r-f power amplifier. It is probable that after following the above procedure the grid currents will be fairly well balanced, but in itself it is not a safe indicator of balance of grid excitation.

In audio power amplifiers operating in Class-AB₁ or Class-AB₂, the idle d-c plate current per tube should be balanced by separate bias adjustments for each tube. In many cases some lack of balance of the plate currents will have negligible effect on the overall performance of the amplifier.

SECTION D

When tubes are operating in the idle position close to cut-off, operation is in a region where the plate current cannot be held to a close percentage tolerance. At this point the action of the positive screen and plate voltages is in delicate balance with the opposing negative grid voltage. The state of balance is indicated by the plate current. Very minor variations of individual grid wires or diameter of grid wires upset the balance, and it is practically impossible to control such minor variations in manufacture. In many audio amplifier applications, especially where the larger power tetrodes are used, the circuit should be designed to permit the bias to be adjusted individually on the tubes.

D-7. Harmonic Amplifiers and Control of Harmonics

The use of power tetrodes to give good efficiency in harmonic amplifiers and to control the presence of unwanted harmonics in the output circuit is inherently sound. Because of the shielding built into the tetrode, the coupling between the output and input circuits (and the input and output circuits) has been reduced to a negligibly small value. (To estimate harmonic amplifier performance see Brown¹² and the Eimac application bulletin "Tube Performance Computer"¹⁰.)

A pulse of plate current delivered by the tube to the output circuit contains energy on the fundamental and most harmonic frequencies. The output plate circuit resonance, coupling, and shielding must be designed to select the desired frequency and avoid radiation of the undesired frequencies.

It is not generally appreciated that the pulse of grid current also contains energy on the harmonic frequencies and control of these harmonic energies may be quite important. The ability of the tetrode to isolate the output circuit from the input circuit over a very wide range of frequencies is important in avoiding feed-through of harmonic voltages from the grid circuit. An important part of this shielding is the fact that properly designed tetrodes permit the construction of complete shielding in the amplifier layout so that coupling external to the tube is also prevented.

It has been found that the plate circuit efficiency of tetrode harmonic amplifiers is quite high. In triode amplifiers, if feed-back of the output harmonic frequency occurs, the phase of the voltage fed back is usually such as to reduce the harmonic content of the plate pulse, and thereby lower the plate circuit efficiency. Since

tetrodes have negligible feedback, the efficiency of a harmonic amplifier is usually up to expected efficiencies.

Also, the high amplification factor of a tetrode causes the plate voltage to have little effect on the flow of plate current, and it is easier to obtain plate pulses with high harmonic energies without using excessive grid bias. A well designed tetrode also permits large r-f voltages to be developed in the plate circuit while still passing high peaks of plate current in the r-f pulse. These two factors help further to increase the plate efficiency.

In r-f amplifiers operating either on the fundamental or a desired harmonic frequency, the control of unwanted harmonics is very important. The subject is well covered in the literature discussing the reduction of interference with television receivers. The following steps permit reduction of the unwanted harmonic energies present in the output circuit:

1. The circuit impedance between plate and cathode should be very low for the high harmonic frequencies. Usually this is obtained by having some or all of the tuning capacitance of the resonant circuit close to the tube.
2. Complete shielding of the output compartment.
3. The use of inductive output coupling from the resonant plate circuit and possibly a capacitive or Faraday shield between the coupling coil and the tank coil, or a high frequency attenuating circuit such as a pi, or pi-L net.
4. The use of low pass filters for all supply leads and wires coming into the output and input compartments.
5. The use of resonant traps for particular frequencies.

D-8. Driving Power Requirements

The technical data sheet for a particular tube gives the approximate driving power required. For radio frequencies below the VHF region, the driving powers are obtained by calculation and confirmed by direct tests. The listed driving power gives the total power taken by the tube grid and the bias circuit. This driving power figure does not allow for losses in the r-f resonant circuit since such losses depend principally on the design of that circuit. The circuit losses can be kept to a low value by proper design. Some allowance for them must be made, however, in determining the total driving power to be supplied by the driver stage.

In the case of tetrodes operating in the VHF and UHF region, the approximate driving power given under typical operation on the data sheets is obtained by direct measurement in operating equipment. Because it is impossible to separate the circuit action and the tube action, the driving power listed is the total power taken by the tube and a practical amplifier circuit.

The total driving power required from the exciter stage in the VHF and UHF region is presumably composed of the following:

1. The power taken by the grid itself and the bias circuit (which is equal to that for the same grid voltages and current acting in a low frequency circuit).
2. The resistance losses caused by the r-f charging currents passing through the leads of the tube into the tube capacitances.
3. Power fed through to the output circuit and power dissipated on plate and screen due to the presence of cathode lead inductance.
4. Excess energies taken on by the space current electrons within the tube due to the rapidly varying grid voltage. Some of this excess energy shows up in bombardment of the cathode and general tube structure.
5. Some dielectric loss in the insulating material of the tube envelope.
6. Losses in the r-f grid circuit and a portion of the input line coupled to the driving circuit.

The total driving power in the VHF and UHF region is often greater than the grid dissipation capability of the tube. As indicated above, the portion of the driving power which appears as grid dissipation can be calculated in the normal manner¹³ (d-c grid current times the peak positive grid voltage).

D-9. VHF and UHF Operating Conditions for Satisfactory Plate Efficiency and Minimum Drive.

When operating a tube in the VHF and UHF region the driving power can usually be minimized without appreciably affecting the plate conversion efficiency, by the following steps:

1. A minimum d-c control grid bias should be used. Frequently, it is advisable to bring this down to approximately cut-off.
2. A high value of d-c screen voltage is advisable even though it appears to increase the fraction of the cycle during which plate current flows.
3. Using the minimum r-f excitation voltage necessary to obtain plate circuit performance, even though the d-c grid current is considerably lower than one would expect at lower frequencies.
4. The cathode lead inductance common to the output and input circuits should be kept to a low value.

It is found that the choice of driving conditions as indicated above does not necessarily decrease the plate efficiency as much as at lower radio frequencies. The steps indicated above should be tried experimentally to determine whether or not the plate circuit efficiency is appreciably effected. As will be indicated below under section E-3, it is preferable to sacrifice plate efficiency somewhat and improve the life expectancy of the tube in the VHF and UHF region.

It has also been observed that optimum output power at these frequencies is obtained when the loading is greater than would be used at lower frequencies. Apparently the use of lower r-f voltage in the plate circuit is desirable. Fortunately, this same condition reduces driving power and screen current and, as will be noted later, improves life expectancy.

LIFE

E-1. Maximum Tube Ratings.

The technical data sheet for each tube type gives the basic maximum ratings for each class of service. Also on the technical data sheet will be found references to cooling air and maximum temperature, and mechanical considerations as they may affect life. Careful observance of the information on the data sheet will avoid damage to the tube and shortening of its useful life. A

reprint on Vacuum Tube Ratings is available¹³.

In general, the tube ratings are so chosen that operation within the ratings will give a minimum of 1000 hours of guaranteed life. The typical life expectancy is therefore considerably greater and will depend upon a great many factors, some of which are discussed below. In general, operation below the maximum ratings will increase the life expectancy of the tube. This

is especially true with reduction in the plate dissipation of the tube. Very roughly speaking, the life expectancy will go up directly as the plate dissipation and total watts being handled by the tube go down.

If tubes are to be used in pulse service with short pulses and appreciable off-time between pulses, the tube ratings are quite different. For information and assistance on pulse application write to the Field Engineering Department of Eitel-McCullough, Inc., San Bruno, California, or refer to Application Bulletin No. 3 "Pulse Service Notes"¹⁴.

E-2. Cooling

Adequate cooling of the tube envelope and metal-to-glass seals is one of the principle factors affecting tube life. Deteriorating effects increase directly with the temperature of the tube envelope and seals. The technical data sheet for the particular tube type should be studied thoroughly with reference to the air cooling requirements. Even if no air cooling is specified, ample free space for circulation of air around the tube is required or else some air must be forced past the tube.

Excess cooling air will have only beneficial results and inadequate cooling air is almost certain to invite premature failure of the tube.

Tubes operated in the VHF and UHF region are inherently subjected to greater heating action than tubes operated at lower frequencies. This results directly from the flow of larger r-f charging currents into the tube capacitances, dielectric losses, and a tendency for electrons to bombard parts of the tube structure other than the normal grid and plate. See section E-3 for a discussion of "VHF and UHF Life Considerations." Greater cooling air is therefore required at these higher frequencies. For tubes designed to operate in the VHF and UHF region, such as the Eimac tetrodes, the cooling air is specified for the normal top frequencies of the tube.

E-3. VHF and UHF Life Considerations

A tube designed for VHF and UHF work must have very small size if practical resonant circuits are to be built around them. Furthermore, these tubes operate less efficiently and have much greater incidental losses than at lower frequency. For these reasons, the power which must be dissipated from the electrodes and tube envelope seals is very much greater per unit of area than for tubes designed solely for low frequency.

If the tubes are to become a part of a VHF line circuit or cavity UHF circuit, the inductance associated with the electrode supports and leads must be reduced to a very small value. In the case of the 4X150A, 4X150G, and 4X500A, some of the electrode leads and supports take the form of large surfaces, conical or cylindrical in shape, and extremely short. This means that the amount of heat conducted out through the metal-to-glass seals is greatly increased. It also means that the terminal connections of the tube are large surfaces with relatively thin walls.

The mechanical layout of sockets, connections, and circuits close to the tube must allow ample cooling air to be blown against the tube seals and surfaces. Also ample contacting surface to carry the heavy radio frequency charging currents must be provided. Since these two requirements may tend to conflict, considerable thought must be given to an adequate layout.

E-3-a. Connectors

Where the tube terminals are large cylindrical surfaces, the contacting portions of the socket are either spring collets or a multiplicity of spring fingers. Usually these multiple contacting surfaces are made of beryllium copper to preserve the spring tension at the relative high temperatures present on tube terminals and are silver plated to reduce r-f resistance.

Rigid clamping connectors should be avoided even though the radius of the curvature seems to be close to that of the cylindrical contacting surface of the tube. It has been found that such rigid clamping connectors will distort the tube terminal and fracture the adjacent metal-to-glass seal. Similarly set screw connecting devices are questionable on large cylindrical tube terminals unless they act to distribute the pressure uniformly and without any distorting effects.

If the connectors fail to provide multiple contacts to the cylindrical tube seals, concentration of r-f charging current will result and the overheating may be destructive. Once the connector loses its spring action the heating is aggravated and damage to the tube is very apt to occur. All tube connectors should be inspected and serviced regularly to be sure that uniform, good contact to the tube results.

E-3-b. Tube Temperatures

Forced air cooling of the seals and tube envelope, as well as of an external anode, is imperative. Both air flow and maximum temperatures are given on the data sheets and both

should be measured to be certain that ample air and cooling results. The problem of making temperature measurements under these conditions is severe. The most practical technique has been to use a very light spray of very thin temperature indicating paint, such as Tempilaq—made by the Tempil Corporation, 132 West 22nd Street, New York 11, N. Y. By using an extremely thin spray and not covering solidly, a temperature gradient across the indicating paint due to the action of the cooling air will be avoided. For further discussion see Eimac application bulletin¹⁵ on the subject.

E-3-c. Backheating by Electrons

Another action involving the motion of electrons within the tube is present at VHF and UHF and has been commonly referred to as backheating of the cathode. Due to the fact that the time of flight of the electrons from the cathode through the grid structure to the plate becomes an appreciable part of the cycle, the electrons can be stopped in flight and turned back by the rapidly changing grid voltage. Under these conditions the electrons are turned back or deflected from their normal paths and given excess energy with which the electrons bombard the cathode and other portions of the tube structure. This effect can be greatly aggravated by the choice of operating conditions to the extent that very destructive effects occur. The tube can even be destroyed within a few minutes under severe conditions.

Fortunately, the conditions which tend to minimize this back-bombardment by electrons are the same as those giving minimum driving conditions as discussed under "VHF Operating Conditions" section D-9. The tendency for electrons to be turned back in flight is reduced by the use of the lowest possible r-f grid voltage on the tube. This is obtained by using the lowest possible d-c grid bias. In tetrodes this effect is inherently much lower because of the action of the d-c accelerating voltage on the screen of the tube. The d-c screen voltage acts to continue accelerating the electrons toward the anode, and also inherently permits the use of very much smaller grid voltages. Consequently, under favorable conditions the number of electrons turned back to heat the cathode and tube structure can be kept to a practical low level. In addition to the use of low d-c grid bias, a high screen voltage is desirable.

At the same time the plate circuit should

always operate with heavy loading (low external plate impedance) so that the minimum instantaneous value of plate voltage shall stay sufficiently positive to continue accelerating electrons to the anode. For this reason best life is had when the tetrode amplifier is heavily loaded as indicated by having small values of d-c screen and d-c control grid current.

NEVER OPERATE WITH LIGHT PLATE LOADING. If the plate load is removed so that the minimum instantaneous plate voltage tends to fall to values around cathode potential (as it must do when the loading is removed completely and excitation is present), the number of electrons turned back can be completely destructive to the tube. It has been found that under conditions of "no loading" the electron bombardment of the insulating glass portion of the tube is often sufficient to cause a suck-in of the glass. Automatic protection should be installed to remove all voltages from the tube when the plate circuit loading becomes too light for the amount of excitation applied.

It should be noted that parasitic oscillations are seldom loaded heavily, as indicated by the high grid currents often had during such self oscillation. Thus excessive r-f plate voltages are developed which at VHF can be damaging in the same manner as unloaded operation on a VHF fundamental frequency. Should such unloaded VHF parasitic oscillation be present simultaneously with apparently satisfactory operation on the fundamental, unexplained reduction of life may result.

Occasionally, also, an output line circuit can resonate simultaneously to a harmonic frequency as well as to the fundamental frequency. The higher resonant modes of practical line circuits are not normally harmonically related, but sometimes the tuning curve of a mode will cross the fundamental tuning curve and at that point the circuit will build up resonant voltages at both the harmonic frequency and fundamental frequency. The harmonic resonance is usually lightly loaded and the damaging action is similar to that of lightly loaded parasitic or fundamental operation. Again the operation of the tube and circuit on the fundamental may appear normal, but with lower than expected efficiency, and damaging action to some degree can occur.

In addition to operating the tube with minimum bias, high screen voltage, and heavy loading on the plate circuit, some degree of com-

compensation for the remaining back heating of the cathode may be required. This can be accomplished by lowering the filament voltage or heater voltage until the cathode operates at normal temperature. It has been found with tetrodes that by taking precautions necessary to minimize

back bombardment by electrons the compensation for back heating of the cathode is not large and may often be neglected. In cases where it is suspected, it is advisable to discuss the subject in detail with the Field Engineering Department of Eitel-McCullough, Inc., in San Bruno, California.

TECHNICAL ASSISTANCE

The Field Engineering Department of Eitel-McCullough, Inc., will gladly assist tube users in the choice of tubes and operating conditions. This is especially important where a prototype design of

equipment and later manufacture is planned. Such assistance makes use of the accumulated detailed experience with the tube types involved and is handled confidentially and without charge.

REFERENCES

1. Atkins & Mandoli, "500 Watts of Audio from AB₁," QST, p. 13, March, 1948 QST, p. 10, June, 1948
2. Byron Ballou, "Keying the Tetrode Amplifier," QST, p. 46, Dec., 1947
3. Don Mix, "Parasitics," QST, p. 19, June, 1948
4. G. W. Fyler, "Parasitics & Instability in Radio Transmitters," Proc. I.R.E., Sept., 1935
5. C. F. Bane, "Final Final," CQ, p. 15, Dec., 1948, and "A Page from a Designer's Notebook," CQ, p. 19, March 1949
6. Warren B. Bruene, "Single-Ended Tetrode Final," CQ, p. 11, Aug., 1950
7. C. A. Hultberg, "Neutralization of Screen-Grid Tubes to Improve the Stability of Intermediate-Frequency Amplifiers" Proceedings of IRE, p. 663, Dec. 1943
8. W. G. Wagener, "500-Mc. Transmitting Tetrode Design Considerations," Proc. I.R.E., vol. 36, No. 5, May, 1948
9. Application Bulletin No. 4, "Calculating Tube Performance," Eitel-McCullough, Inc., San Bruno, California
10. Application Bulletin No. 5, "Tube Performance Computer," Eitel-McCullough, Inc., San Bruno, California
11. Eimac 4-65A Technical Data Sheet, Eitel-McCullough, Inc., San Bruno, California
12. Robert H. Brown, "Harmonic Amplifier Design," Proc. I.R.E., vol. 35, pp. 771-777, August, 1947
13. Application Bulletin No. 6, "Vacuum Tube Ratings," (Reprinted from January, 1945 industrial edition of the Eimac News) Eitel-McCullough, Inc., San Bruno California
14. Application Bulletin No. 3, "Pulse Service Notes," Eitel-McCullough, Inc., San Bruno, California
15. Application bulletin No. 7, "Vacuum Tube Temperature Measurements," Eitel-McCullough, Inc., San Bruno, California

NOTES

NOTES

considered for the remaining heat heating cathode may be required. This can be accomplished by lowering the filament voltage or heater voltage until the cathode operates at normal temperature. It has been found with tetrodes that by taking precautions necessary to maintain

the heat heating of the cathode is not large and may often be neglected. In cases where it is neglected, it is advisable to discuss the subject in detail with the Field Engineering Department of Eitel-McCullough, Inc., in San Bruno, California.

TECHNICAL ASSISTANCE

The Field Engineering Department of Eitel-McCullough, Inc., will gladly assist tube users in the choice of tubes and operating conditions. This is especially important where a prototype design of

equipment and later manufacture is planned. Such assistance makes use of the accumulated detailed experience with the tube types involved and is handled confidentially and without charge.

REFERENCES

1. Atlas & Maudslayi, "600 Years of Audio from AR," QST, p. 75, March, 1944 QST, p. 10, June, 1948
2. Cyril Taylor, "Kettle-He-Dee-dee Amplifier," QST, p. 50, Dec., 1947
3. Don McE, "Parasitics," QST, p. 46, June, 1948
4. G. W. Feltz, "Distortion & Instability in Radio Transmitters," Proc. I.R.E., Sept., 1945
5. C. F. Ross, "Fixed-Fuel," CQ, p. 35, Dec., 1947 and "A Page from a Dadger's Notebook," CQ, p. 41, March 1947
6. Wayne A. Brown, "Single-Ended Tetrode Push," CQ, p. 71, Aug., 1948
7. G. A. Stubbins, "Neutralization of Screen Grid Tubes to Improve the Stability of Intermediate-Frequency Amplifiers," Proceedings of IRE, p. 364, Dec. 1947
8. W. G. Wegener, "150-Mc. Transmitting Tetrode Design Considerations," Proc. I.R.E., vol. 35, No. 5, May, 1947
9. Application Bulletin No. 4, "Calculating Tube Performance," Eitel-McCullough, Inc., San Bruno, California
10. Application Bulletin No. 5, "Tube Performance Calculator," Eitel-McCullough, Inc., San Bruno, California
11. Binac A-656 Technical Data Sheet, Eitel-McCullough, Inc., San Bruno, California
12. Robert H. Baker, "Triaxial Amplifier Tubes," Proc. I.R.E., vol. 39, pp. 771-777, August 1951
13. Application Bulletin No. 6, "Vacuum Tube Ratings," (Reprinted from January, 1945 Industrial Edition of the Etsac News), Eitel-McCullough, Inc., San Bruno, California
14. Application Bulletin No. 2, "Tube Service Notes," Eitel-McCullough, Inc., San Bruno, California
15. Application Bulletin No. 7, "Vacuum Tube Temperature Measurements," Eitel-McCullough, Inc., San Bruno, California

22184

Eitel-McCulloch
EITEL-McCULLOUGH, INC.
SAN BRUNO, CALIFORNIA

TETRODES



4-65A



4PR60A



4-125A



4X150A



4-250A



**QUICK-REFERENCE
CATALOGUE**
EFFECTIVE
DECEMBER 1, 1952

TRIODES



4X500A



4-1000A



4W20000A



25T



35T



35TG



75T



2C39A



100T



152T



250T



304T



450T



750T

PENTODE



1000T



1500T



2000T



3X2500A3



3X2500F3



3W10000A3



4E27A/5-125B

RECTIFIERS



2-150D



KY21A



8020



2-150D

Eimac
TUBES

EITEL-McCULLOUGH, INC.
San Bruno, California

www.SteamPoweredRadio.Com

LANEOUS



250R



Variable Vacuum Capacitor



VC, Fixed, Vacuum Capacitor



Air-system Sockets



HR, Heat Dissipating Connectors



Diffusion Pump



Vacuum Switch

4PR60A High-vacuum, radial-beam, pulse modulator tetrode. Oxide cathode internal anode. Unilateral replacement for 715B, 715C, and 5D21.	6.0	3.06	26.0	2.2	90,000	Pulse Mod	...	20,000	18	60	20,000	1,250	-800	15
4W20000A 20 Kw., water-cooled, high transconductance radial beam, power tetrode. Unipotential thoriated tungsten cathode, non-emitting grid, external anode. Concentric VHF terminals.	12.0**	5.0	10.0†	30.0	75,000	B TV	220	8,000	15 (avg.)	20,000	5,500	1,200	-240	7.1	20,100*
						C CW	220	8,000	15	20,000	7,000	1,200	-400	3.4	...	830	13,000+
4X150A 150-watt plate dissipation, forced - air cooled, general purpose, high transconductance radial-beam power tetrode. Oxide coated cathode, external anode. Operates in normal amplifier service through 500 Mc.	2.47	1.65	A 6.0 D 26.5	2.6	12,000	B Aud.	...	1,250	.250	150	1,250	300	-44	.180/.475	5,600	0.075	425
						B TV	500	1,250	.250 (avg.)	150	1,250	300	-70	.305	250*
						C CW	500	1,250	.250	150	1,250	250	-90	.200	...	1.2	195
4X150G 150-watt plate dissipation, forced-air cooled, general purpose radial-beam power tetrode. Oxide coated cathode, external anode. Concentric UHF terminals. Operates up through 1000 Mc.	2.63	1.65	2.5	6.25	12,000	C CW	750	1,250	.250	150	1,250	250	-60	.200	...	9	100+
						Plate Pulse	1,200	7,000	*	150	7,000	1,000	-250	6.0	20,000+
						C CW	110	4,000	.350	500	4,000	500	-250	.315	...	13	980+
4X500A 500-watt plate dissipation, forced - air cooled, general purpose radial-beam power tetrode. Thoriated tungsten filament, non-emitting grids, external anode.	4.75	2.63	5.0	13.5	5,200	C CW	110	4,000	.350	500	4,000	500	-250	.315	...	13	980+
						B TV	220	3,000	.350	500	2,400	500	-100	.400	3,000	25	600+
4E27A/5-125B 125-watt plate dissipation, radiation cooled, general purpose radial-beam power pentode. See Note 1.	6.19	2.75	5.0	7.5	2,150	B Aud	...	4,000	.200	125	2,500	500	-85	.065/.250	20,000	.2	400
						C CW	75	4,000	.200	125	3,000	500	-200	.167	...	2	375
						AM Pl	75	3,200	.160	85	2,500	500	-200	.152	...	2	295

PENTODE

See page 5 for explanation of class of service symbols.

Note 1. Thoriated tungsten filament, non-emitting grids, pyrovac plate.

* Max. pulsed cathode current 7 amps., Max. pulse duration 5 microseconds.

** Does not include water couplings.

† Typical operation at maximum frequency for full rating.

‡ Bombardment heated cathode, requires 1600v DC at 1.9 amps.

* Peak synchronizing level.

BASING



4-125A
4-250A
4-400A
4-1000A
4X500F



4E27A/5-125B



4-65A



4PR60A

SPECIAL

4X150A
4X150D
4X150G
4X500A
4W20000A

VACUUM PUMPS & GAUGES · SWITCHES · SOCKETS · HEAT DISSIPATING CONNECTORS · MISC. 5

RECTIFIERS · VACUUM CAPACITORS 4

TRIODES · KLYSTRONS 3

TRIODES 2

TETRODES · PENTODES 1

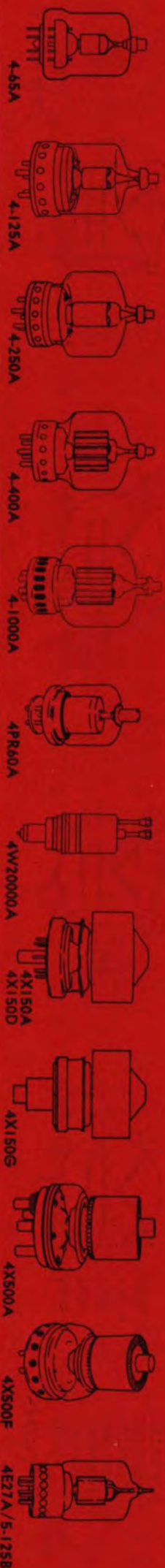

TETRODES

TYPE	DESCRIPTION	MAXIMUM DIMENSIONS		FILAMENT		TRANSCONDUCTANCE μmhos	CLASS OF SERVICE	Max. Frequency Full Rating Mc.	MAX. PLATE RATINGS			TYPICAL OPERATING CONDITIONS																									
		Length Inches	Diameter Inches	Volts	Amps.				DC Volts	DC Amps.	Disipation Watts	DC Plate Volts	DC Screen Volts	DC Grid Volts	DC Plate Amps	Plate Load Ohms	Driving Power Watts	Power Output Watts																			
4-65A	65-watt plate dissipation, radiation cooled, general purpose radial-beam power tetrode. See Note 1.	4.38	2.38	6.0	3.5	4,000	B Aud	...	3,000	.150	65	1,800	250	-35	.050/.220	20,000	1.1	270																			
																			C CW	150	3,000	.150	65	3,000	250	-90	.115	...	1.7	280							
																			AM PI	150	2,500	.120	45	2,500	250	-150	.108	...	1.9	225							
4-125A	125-watt plate dissipation, radiation cooled, general purpose radial-beam power tetrode. See Note 1.	5.69	2.87	5.0	6.5	2,450	B Aud	...	3,000	.225	125	2,500	350	-43	.093/.260	22,200	2.4	400																			
																			C CW	120	3,000	.225	125	3,000	350	-150	.167	...	2.5	375							
																			AM PI	120	2,500	.200	85	2,500	350	-210	.152	...	3.3	300							
							4-250A	250-watt plate dissipation, radiation and forced-air cooled, general purpose radial-beam power tetrode. See Note 1.	6.38	3.56	5.0	14.5	4,000	C CW	110	4,000	.350	250	4,000	500	-225	.312	...	2.5	1,000												
																										AM PI	110	3,200	.275	165	3,000	400	-310	.250	...	3.5	585
																										B Aud	...	4,000	.350	400	3,000	500	-90	.120/.638	14,000	3.5	1,750
4-400A	400-watt plate dissipation, radiation and forced-air cooled, general purpose radial-beam power tetrode. See Note 1.	6.38	3.56	5.0	14.5	4,000	C CW	110	4,000	.350	400	4,000	500	-220	.350	...	6	1,100																			
																			C CW	110	4,000	.350	400	4,000	400	-170	.270	...	10	720 +							
																			AM PI	110	3,200	.275	270	3,000	400	-310	.275	...	4	640							
4-1000A	1000 - watt plate dissipation, radiation and forced-air cooled, general purpose radial-beam power tetrode. See Note 1.	9.63	5.25	7.5	21.0	10,000	B Aud	...	6,000	.700	1,000	6,000	500	-75	.150/.950	15,000	4.7	3,900																			
																			C CW	110	6,000	.700	1,000	6,000	500	-200	.700	...	15	3,400							
																			C CW	110	6,000	.700	1,000	6,000	500	-180	.625	...	200	2,600 +							
AM PI	30	5,500	.600	670	5,500	500	-200	.600	...	9	2,630																										

6C21 High-vacuum, radiation cooled, pulse modulator triode. Thoriated tungsten filament, non-emitting grid, pyrovac plate	12.63	5.13	8.2	16.8	5,800	Pulse Mod	...	30,000	15	300	27,000	-1500	3100	15	1,600
25T 25-watt plate dissipation, radiation cooled, general purpose triode. Thoriated tungsten filament, non-emitting grid, pyrovac plate.	4.38	1.44	6.3	3.0	2,500	B Aud	...	2,000	.075	25	1,250	-42	135	.024/.130	21,400	3.4	112
						C CW	60	2,000	.075	25	2,000	-130063	...	4	100
						AM Pl	60	1,600	.060	17	1,600	-170053	...	3.1	68
35T 50-watt plate dissipation, 35TG radiation cooled, general purpose triode. Thoriated tungsten filament, non-emitting grid, pyrovac plate.	5.5	1.81	5.0	4.0	2,850	B Aud	...	2,000	.150	50	2,000	-40	130	.034/.167	27,500	4	235
						C CW	100	2,000	.150	50	2,000	-135125	...	13	200
						AM Pl	100	1,600	.120	33	1,500	-150090	...	11	105
75TH 75-watt plate dissipation, radiation cooled, general purpose triode. Thoriated tungsten filament, non-emitting grid, pyrovac plate. H version high-mu, L version low-mu.	7.25	2.81	5.0	6.25	4,150 L 3,350	B Aud	...	3,000	.225	75	2,000	-90	175	.050/.225	19,300	3	300
						C CW	40	3,000	.225	75	2,000	-190	300	.050/.250	18,000	5	350
						AM Pl	40	2,400	.180	50	2,000	-200150	...	10	225
100TH 100-watt plate dissipation, radiation cooled, general purpose triode. Thoriated tungsten filament, non-emitting grid, pyrovac plate. H version high-mu, L version low-mu.	7.75	3.19	5.0	6.3	4,500 L 3,000	B Aud	...	3,000	.225	100	2,500	-50	155	.060/.280	22,000	7.5	425
						C CW	40	3,000	.225	100	3,000	-145	290	.048/.250	...	10	400
						AM Pl	40	2,500	.180	65	2,500	-200165	...	18	20

See page 5 for explanation of class of service symbols.

Note 2: Thoriated tungsten filament, non-emitting grid, external anode.

A Concentric VHF terminals. F Flexible lead terminals.

† Typical operation, grounded grid at full rating.

‡ Bombardment heated cathode, requires 1600v. DC at 1.9 amps.

**Does not include water couplings.

†Cathode Current

BASING



6C21



25T



35T



35TG
75TH
75TL
100TH
100TL

SPECIAL

2C39A
3W5000A3
3W5000F3
3W10000A3
3X2500A3
3X2500F3
3X3000A1
3X3000F1

BASING



4-125A
4-250A
4-400A
4-1000A
4X500F



4E27A/5-125B



4-45A



4PR60A

SPECIAL

4X150A
4X150D
4X150G
4X500A
4X500A
4W20000A

VACUUM PUMPS & GAUGES · SWITCHES · SOCKETS · HEAT DISSIPATING CONNECTORS · MISC. RECTIFIERS · VACUUM CAPACITORS

TRIODES · KLYSTRONS

TRIODES



TYPE	DESCRIPTION	MAXIMUM DIMENSIONS		FILAMENT		TRANSCONDUCTANCE μmhos	CLASS OF SERVICE	Max. Frequency Full Rating Mc.	MAX. PLATE RATINGS			TYPICAL OPERATING CONDITIONS						
		Length Inches	Diameter Inches	Volts	Amps.				DC Volts	DC Amps	DC Dissipation Watts	DC Plate Volts	DC Grid Volts	Peak A.F. Grid Input Volts Per Tube	DC Plate Amps.	Plate Load Ohms	Driving Power Watts	Power Output Watts
2C39A	Forced-air cooled, planar UHF triode. Oxide coated cathode, external anode. Operates as power amplifier, multiplier, and oscillator to 2500 Mc.	2.75	1.26	6.3	1.0	22,000	C CW	2,500	1,000	.125†	100	800	-20080	...	6	27
							AM Pl											
3W5000A3	5 - Kw. water cooled, general purpose, high transconductance triode. See Note 2.	8.0**	3.0	7.5	51.0	20,000	B Aud	75	6,000	2.5	5,000	6,000	-240	390	.4/3.0	4,650	115	13,000
							C CW											
3W5000F3	cooled, general purpose, high transconductance triode. See Note 2.	8.0**	3.0	7.5	51.0	20,000	AM Pl	75	6,000	2.0	3,350	5,000	-550	...	1.45	...	76	5,580
							A F											
3W10000A3	10-Kw., water-cooled, high transconductance triode. Unipotential thoriated tungsten cathode, non-emitting grid, external anode. Concentric VHF terminals.	13.0**	5.0	10.0†	30.0	55,000	B TV	220	5,000	10	10,000	3,250	-190	...	4.25	560	400	5,500+
							A F											
3X2500A3	2.5-Kw., forced-air cooled, general purpose, high transconductance triode. See Note 2.	9.0	4.16	7.5	51.0	20,000	B Aud	40	6,000	2.5	2,500	6,000	-240	390	.4/3.0	4,650	113	13,000
							C CW											
3X2500F3	air cooled, general purpose, high transconductance triode. See Note 2.	9.0	4.16	7.5	51.0	20,000	C CW	110	4,000	2.0	2,500	4,000	-500	...	1.85	...	1,900	7,500+
							AM Pl											
3X3000A1	3 - Kw., forced-air cooled, low-mu power triode, intended for use as an audio amplifier or modulator. See Note 2.	9.0	4.16	7.5	51.0	11,000	B Aud	40	6,000	2.5	2,500	6,000	-240	390	.4/3.0	4,650	113	13,000
							C CW											
3X3000F1	air cooled, low-mu power triode, intended for use as an audio amplifier or modulator. See Note 2.	9.0	4.16	7.5	51.0	11,000	C CW	110	4,000	2.0	2,500	4,000	-500	...	1.85	...	1,900	7,500+
							AM Pl											
3X3000A1	3 - Kw., forced-air cooled, low-mu power triode, intended for use as an audio amplifier or modulator. See Note 2.	9.0	4.16	7.5	51.0	11,000	B Aud	40	6,000	2.5	2,500	6,000	-240	390	.4/3.0	4,650	113	13,000
							C CW											
3X3000F1	air cooled, low-mu power triode, intended for use as an audio amplifier or modulator. See Note 2.	9.0	4.16	7.5	51.0	11,000	C CW	110	4,000	2.0	2,500	4,000	-500	...	1.85	...	1,900	7,500+
							AM Pl											
3X3000A1	3 - Kw., forced-air cooled, low-mu power triode, intended for use as an audio amplifier or modulator. See Note 2.	9.0	4.16	7.5	51.0	11,000	B Aud	40	6,000	2.5	2,500	6,000	-240	390	.4/3.0	4,650	113	13,000
							C CW											
3X3000F1	air cooled, low-mu power triode, intended for use as an audio amplifier or modulator. See Note 2.	9.0	4.16	7.5	51.0	11,000	C CW	110	4,000	2.0	2,500	4,000	-500	...	1.85	...	1,900	7,500+
							AM Pl											
3X3000A1	3 - Kw., forced-air cooled, low-mu power triode, intended for use as an audio amplifier or modulator. See Note 2.	9.0	4.16	7.5	51.0	11,000	B Aud	40	6,000	2.5	2,500	6,000	-240	390	.4/3.0	4,650	113	13,000
							C CW											
3X3000F1	air cooled, low-mu power triode, intended for use as an audio amplifier or modulator. See Note 2.	9.0	4.16	7.5	51.0	11,000	C CW	110	4,000	2.0	2,500	4,000	-500	...	1.85	...	1,900	7,500+
							AM Pl											
3X3000A1	3 - Kw., forced-air cooled, low-mu power triode, intended for use as an audio amplifier or modulator. See Note 2.	9.0	4.16	7.5	51.0	11,000	B Aud	40	6,000	2.5	2,500	6,000	-240	390	.4/3.0	4,650	113	13,000
							C CW											
3X3000F1	air cooled, low-mu power triode, intended for use as an audio amplifier or modulator. See Note 2.	9.0	4.16	7.5	51.0	11,000	C CW	110	4,000	2.0	2,500	4,000	-500	...	1.85	...	1,900	7,500+
							AM Pl											

TYPE	DESCRIPTION	MAXIMUM DIMENSIONS		FILAMENT		FREQUENCY RANGE Mc.	MAXIMUM RATINGS		CLASS OF SERVICE	TYPICAL OPERATING CONDITIONS																				
		Length Inches	Diameter Inches	Volts	Amps		Beam DC Volts	DC Amps		Collector Dissipation Watts	Beam DC Volts	DC Amps	Driving Power Watts	Power Output Watts																
750TL	750-watt plate dissipation, radiation cooled, general purpose triode. Thoriated tungsten filament, non-emitting grid, pyrovac plate.	17.0	7.13	7.5	21.0	3,500	B Aud	...	10,000	1.0	750	6,000	-390	650	.166/.834	16,300	46	3,500												
																			C CW	40	10,000	1.0	750	6,000	-700625	...	125	3,000
																			AM Pl	40	8,000	.8	500	6,000	-950415	...	75	2,000
1000T	1000-watt plate dissipation, radiation and forced-air cooled, general purpose triode. Thoriated tungsten filament, non-emitting grid, pyrovac plate.	12.3	5.13	7.5	15.5	9,050	B Aud	...	7,500	.750	1,000	6,000	-160	335	.220/1.05	13,300	60	4,600												
																			C CW	50	7,500	.750	1,000	6,000	-350667	...	60	3,000
																			AM Pl	50	6,000	.600	665	6,000	-500600	...	75	2,935
1500T	1500-watt plate dissipation, radiation and forced-air cooled, general purpose triode. Thoriated tungsten filament, non-emitting grid, pyrovac plate.	17.0	7.13	7.5	24.0	10,000	B Aud	...	8,000	1.25	1,500	6,000	-190	570	.330/1.65	8,200	115	7,000												
																			C CW	40	8,000	1.25	1,500	7,000	-500860	...	85	4,500
																			AM Pl	40	6,000	1.00	1,000	6,000	-750835	...	120	4,000
2000T	2000-watt plate dissipation, radiation and forced-air cooled, general purpose triode. Thoriated tungsten filament, non-emitting grid, pyrovac plate.	17.75	8.13	10.0	23.5	11,000	B Aud	...	8,000	1.75	2,000	7,000	-280	600	.300/1.80	9,200	175	8,600												
																			C CW	40	8,000	1.75	2,000	7,000	-600	...	1.15	...	115	6,000
																			AM Pl	40	6,000	1.40	1,350	6,000	-800	...	1.13	...	225	5,400

KLYSTRONS

TYPE	DESCRIPTION	MAXIMUM DIMENSIONS		FILAMENT		FREQUENCY RANGE Mc.	MAXIMUM RATINGS		CLASS OF SERVICE	TYPICAL OPERATING CONDITIONS						
		Length Inches	Diameter Inches	Volts	Amps		Beam DC Volts	DC Amps		Collector Dissipation Watts	Beam DC Volts	DC Amps	Driving Power Watts	Power Output Watts		
3K20000LA	3 gap 20-KW. Collector dissipation, water and forced-air cooled Klystrons for use in UHF TV band. Use of external cavities provides coverage of entire band with three tube types.	A	50.5	9.0†	42.0	A	470-580	13,500	1.7	20,000	C CW	10,000	1.0	10	2,500	
3K20000LF		F	44.0			F	580-720									100 approx.
3K20000LK		K	36.75			K	720-890									

†Cathode bombardment power, 1600 watts (2100 Vdc, 0.75A)
 * Peak synchronizing level.

See page 5 for explanation of class of service symbols.

BASING



4S0TH
4S0TL
1000T



2S0TH
2S0TL



7S0TL
1500T
2000T



1S2TH
1S2TL
304TH
304TL



5S2 / 3-200A3

SPECIAL
 3K20000LA
 3K20000LF
 3K20000LK



4-125A
4-250A
4-400A
4-1000A
4X500F



4E27A/S-125B



4-45A



4PR60A

SPECIAL
 4X150A
 4X150D
 4X150G
 4X500A
 4W20000A



TRIODES

TYPE	DESCRIPTION	MAXIMUM DIMENSIONS		FILAMENT Volts	FILAMENT Amps.	TRANSCONDUCTANCE μ mhos	CLASS OF SERVICE	Max. Frequency Full Rating Mc.	MAX. PLATE RATINGS			TYPICAL OPERATING CONDITIONS						
		Length Inches	Diameter Inches						DC Volts	DC Amps	DC Dissipation Watts	DC Plate Volts	DC Grid Volts	Peak A.F. Grid Input Volts Per Tube	DC Plate Amps.	Plate Load Ohms	Driving Power Watts	Power Output Watts
152TH	150-watt plate dissipation, radiation cooled, general purpose triode. Thoriated tungsten filament, non-emitting grid, pyrovac plate. H version high-mu, L version low-mu.	7.63	2.56	5 or 10	12.5 or 6.25	H 8,300 L 7,150	B Aud C CW AM Pl 40 40	3,000 3,000 2,500	.450 .450 .350	150 150 100	3,000 3,000 2,000	H -150 L -260	430 675	.067/.335 .100/.500	20,300 20,400	3	700
152TL	150-watt plate dissipation, radiation cooled, general purpose triode. Thoriated tungsten filament, non-emitting grid, pyrovac plate. H version high-mu, L version low-mu.	10.13	3.81	5.0	10.5	H 5,600 L 2,650	B Aud C CW AM Pl 40 40	4,000 4,000 3,000	.350 .350 .280	250 250 165	3,000 4,000 3,000	H -65 L -170	260 400	.100/.560 .100/.500	12,250 13,000	42 16	1,180 1,000
250TH	250-watt plate dissipation, radiation cooled, general purpose triode. Thoriated tungsten filament, non-emitting grid, pyrovac plate. H version high-mu, L version low-mu.	7.63	3.56	5 or 10	25 or 12.5	16,700	B Aud C CW AM Pl 40 40	3,000 3,000 2,500	.900 .900 .700	300 300 200	3,000 3,000 2,500	H -150 L -290	210 390	.134/.667 .130/.800	10,200 9,100	6 55	1,400 1,800
304TH	300-watt plate dissipation, radiation cooled, general purpose triode. Thoriated tungsten filament, non-emitting grid, pyrovac plate. H version high-mu, L version low-mu.	12.63	5.13	7.5	12.0	H 6,650 L 5,000	B Aud C CW AM Pl 40 40	6,000 6,000 4,500	.600 .600 .500	450 450 300	5,000 5,000 4,500	H -115 L -240	267 430	.120/.620	18,600 18,500	10 28	2,200
450TH	450-watt plate dissipation, radiation cooled, general purpose triode. Thoriated tungsten filament, non-emitting grid, pyrovac plate. H version high-mu, L version low-mu.	6.0	3.41	10.0	5.0	3,600	B Aud C CW AM Pl 150 150	3,500 3,500 2,600	.250 .250 .200	200 200 130	3,000 3,500 2,500	H -90 L -270	270	.080/.400	18,000	20	820
592/3-200A3	200-watt plate dissipation, radiation cooled, general purpose triode. Thoriated tungsten filament, non-emitting grid, pyrovac plate.	6.0	3.41	10.0	5.0	3,600	C CW AM Pl	150 150	3,500 3,500	.250 .250	200 200	3,500 3,500	-270 -300	.228	18,000	15	600	
																		19

VACUUM CAPACITORS

FIXED TYPE

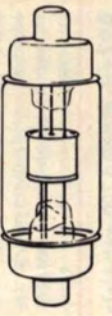

Eimac vacuum capacitors are small, vacuum-dielectric units intended principally for use as all or part of the plate tank capacitance. They are also frequently used as high-voltage coupling and by-pass capacitors at high frequencies and as high-voltage neutralizing capacitors. Overall length 6 3/4", diameter 2 1/4".

TYPE	VC6-20	VC6-32	VC12-20	VC12-32	VC25-20	VC25-32	VC50-20	VC50-32
Capacitance $\mu\mu\text{fd}$	6	6	12	12	25	25	50	50
Max. Peak volts	20,000	32,000	20,000	32,000	20,000	32,000	20,000	32,000
Max. RMS amps.	28	28	28	28	28	28	28	28

VARIABLE TYPE



Eimac variable vacuum capacitors are intended principally for use as plate tank capacitors in radio frequency amplifiers and oscillators. The capacitance variation is linear with respect to shaft rotation and return to previously indexed settings is positive. The low-torque tuning mechanism is designed with adequate bearing surfaces to provide long life.

TYPE	MAX. DIMENSIONS			CAPACITANCE $\mu\mu\text{fd}$	Max. Peak RF Voltage Volts	Max. RMS Current Amps
	Length	Height	Width			
VVC60-20	5.69	...	3.06	10-60	20,000	40
VVC2-60-20	6.28	3.13	8.13	Parallel 20-120 Split Stator 5-30	Parallel 20,000 Split Stator 40,000	Parallel 80 Split Stator 40
VVC4-60-20	6.28	7.81	7.81	40-240	20,000	160

BASING



2-25A



2-50A
8020/100R
866A



2-150D



2-240A



2-2000A



250R



253



872A



KY21A



RX21A

SPECIAL 2-01C



4-400A
4-1000A
4XS00F



4E1/A/3-129B



T-63A



T7A00A

4X150G
4X500A
4W20000A



HIGH VACUUM RECTIFIERS

TYPE	DESCRIPTION	MAXIMUM DIMENSIONS		AVERAGE PLATE CUR. Ma.	PLATE DISSIPATION Watts	PEAK INVERSE VOLTAGE Volts	FILAMENT Volts	FILAMENT Amps.
		Length Inches	Diameter Inches					
2-01C	General purpose UHF instrument diode. Accurate to 700 Mc. 5-volt oxide coated cathode. Resonant frequency 2800 Mc. Suited to probe mounting.	1.81	.563	1	0.1	1,000	5.3	0.4
2-25A	High vacuum rectifier. High voltage, medium current. Instant heating. thoriated tungsten filament. Radiation cooled pyrovac plate.	4.38	1.44	50	15	25,000	6.3	3.0
2-50A	High vacuum rectifier. High voltage, medium current. Instant heating. thoriated tungsten filament. Radiation cooled pyrovac plate.	5.50	1.82	75	30	30,000	5.0	4.0
2-150D	High vacuum rectifier. High voltage medium current. Instant heating. thoriated tungsten filament. Radiation cooled pyrovac plate.	8.88	2.50	250	90	30,000	5.0	13.0
2-240A	High vacuum rectifier. High voltage, high current. Instant heating, thoriated tungsten filament. Radiation cooled pyrovac plate.	11.2	3.82	500	150	40,000	7.5	12.0
2-2000A	High vacuum rectifier. High voltage, high current. Instant heating, thoriated tungsten filament. Radiation cooled pyrovac plate.	17.8	8.13	750	1,200	75,000	10.0	25.0
250R	High vacuum rectifier. High voltage, medium current. Instant heating. thoriated tungsten filament. Radiation cooled pyrovac plate.	10.13	3.82	250	150	60,000	5.0	10.5
253	High vacuum rectifier. High current. Instant heating, thoriated tungsten filament. Radiation cooled pyrovac plate.	8.75	2.50	350	100	15,000	5.0	10.0
8020/100R	High vacuum rectifier. High voltage, medium current. Instant heating. thoriated tungsten filament. Radiation cooled pyrovac plate.	8	2.32	100	60	40,000	5.0	6.5

MERCURY VAPOR TYPES

Peak Plate Amps.

KY21A	Grid-controlled, mercury vapor rectifier. 2.5-volt, oxide coated filament. 750-Ma. average plate current.	7.69	2.25	750	3	11,000	2.5	10.0
RX21A	Mercury vapor rectifier. 2.5-volt, oxide coated filament. 750-Ma. average plate current.	7.63	2.25	750	3	11,000	2.5	10.0
866A	Mercury vapor rectifier. 2.5 volt, oxide coated filament. 250-Ma. average plate current.	6.5	2.5	250 500	1 2	10,000 2,000	2.5	5.0
872A	Mercury vapor rectifier. 5.0-volt, oxide coated filament. 1.25 amperes average plate current.	8.5	2.31	1,250	5	10,000	5.0	7.5

AIR-SYSTEM SOCKETS

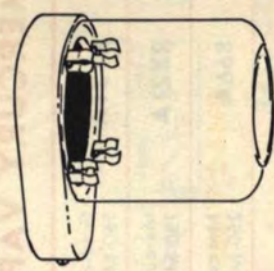

4-400A
This socket is designed to simplify cooling of the 4-400A Eimac tetrode. Its use insures distribution of the correct amount of cooling air to the various seals of the tube with the most economical blower size.

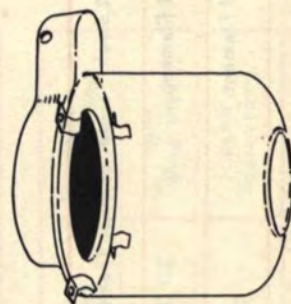

4-1000A
This socket is specifically designed for use with the Eimac 4-1000A tetrode. Its function with this tube is the same as the 4-400A socket. These sockets are supplied with all the necessary mounting screws, ground clips, and a pyrex glass chimney for cooling the plate seal area.

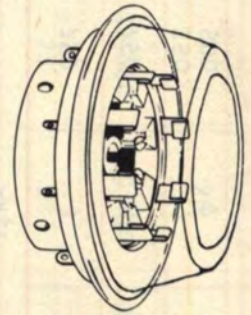

4X150A
This socket is designed for use with the Eimac 4X150A power tetrode. In addition to insuring adequate cooling, it makes possible improved circuit arrangements in high frequency applications. It employs a built-in screen to cathode bypass capacitor. Its compact construction reduces lead inductance to a minimum.

COMPLETE DATA

ON PRODUCTS LISTED IN THIS CATALOGUE ARE AVAILABLE

A complete technical data sheet for a specific tube type will be sent upon request. Such data sheets are also included in the package with each tube. The sheet contains application information in addition to electrical and mechanical data.

If you wish help in selecting the proper tube type or proper operating conditions for an application, please write for advice to:

Application Engineering Dept.
EITEL-MCCULLOUGH, INC.
S A N B R U N O , C A L I F O R N I A

HR HEAT DISSIPATING CONNECTORS

HR Heat Dissipating Connectors are machined from solid dural rod, and are supplied with the necessary machine screws. The table below lists the proper connectors for use with each Eimac tube type.

TUBE	Plate Connector	Grid Connector	TUBE	Plate Connector	Grid Connector
2-25A	HR-1	HR-1	75TH-TL	HR-3	HR-2
2-80A	HR-3	HR-3	100TH-TL	HR-6	HR-2
2-150D	HR-6	HR-6	VT127A	HR-3	HR-3
2-240A	HR-4	HR-4	152TH-TL	HR-5	HR-6
2-2000A	HR-8	HR-8	250TH-TL	HR-6	HR-3
3C24	HR-1	HR-1	250R	HR-6	HR-3
4-45A	HR-4	HR-4	253	HR-8	HR-6
4-125A	HR-6	HR-6	304TH-TL	HR-7	HR-6
4-250A	HR-6	HR-6	327A	HR-4	HR-3
4-400A	HR-6	HR-6	450TH-TL	HR-8	HR-8
4-1000A	HR-8	HR-8	592/3-200A3	HR-10	HR-5
4E77A/5-1258	HR-5	HR-5			HR-5
4PR60A	HR-8	HR-8			HR-8
6C21	HR-8	HR-8	750TL	HR-8	HR-8
KY21A	HR-3	HR-3	866A	HR-8	HR-8
RX21A	HR-3	HR-3	872A	HR-8	HR-8
25T	HR-1	HR-1	1000T	HR-9	HR-9
35T	HR-3	HR-3	1500T	HR-8	HR-8
35TG	HR-3	HR-3	2000T	HR-8	HR-8
UH50	HR-2	HR-2	8020(100R)	HR-8	HR-8

TYPE	Length	Dia.	Hole Dia.
HR-1	11/16"	1/2"	.052"
HR-2	11/16"	1/2"	.062"
HR-3	11/16"	1/2"	.070"
HR-4	7/8"	3/4"	.102"
HR-5	7/8"	3/4"	.125"
HR-6	7/8"	3/4"	.359"
HR-7	1-11/32"	1-3/8"	.125"
HR-8	1-11/32"	1-3/8"	.570"
HR-9	4-11/32"	1-3/8"	.570"
HR-10	1-11/32"	1-3/8"	.510"



HR-1-2-3



HR-4-5-6



HR-7-8-10



HR-9

VACUUM PUMP

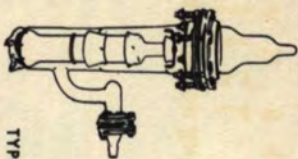

TYPE HV-1

A glass barrel, triple-jet, air-cooled vacuum pump of the oil-diffusion type. Ultimate vacuum of 4×10^{-7} mm of mercury. Speed without baffle approximately 67 liters per second. Simple to operate, requires no liquid cooling, cold trap, or charcoal trap. Can be disassembled with wrenches. Heater voltage 110 volts. Current 1.7 amperes. Overall length below high-vac manifold $1 \frac{1}{2}$ ". Shipping weight 18 pounds. Complete assembly includes flanges and nipples for connecting to high-vacuum manifold and forepump system, together with necessary gaskets and complete operating instructions.

IONIZATION GAUGE

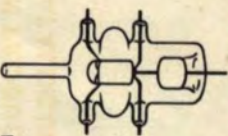

100 IG

Essentially a triode vacuum tube with a pure tungsten filament and molybdenum electrodes for measuring pressures from 10^{-7} to less than 10^{-2} mm of mercury, constructed of "hard" glass for sealing directly to nonex glass vacuum systems.

VACUUM SWITCH

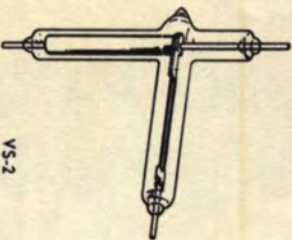

VS-2

A single pole, double throw switch with contacts in high vacuum for high voltage switching. Contact spacing .015". Switch will handle r-f potentials as high as 20 Kv. In DC switching will handle approximately 1.5 amps. at 5 Kv.



CONTACT FINGER STOCK

Eimac pre-formed contact finger stock is especially suitable for making connections to coaxially constructed tubes and those of external-anode design. The heat-treated copper alloy material is silver plated for low r-f losses. It may be bent on a one-half inch radius without breaking.

Contact finger stock may be obtained without heat treatment or silver plating upon request.

↓ TYPE	WIDTH Inches	MATERIAL THICKNESS Inches	FINGER DEFLECTION Inches
17/32"	17/32	.008	1/32
31/32"	31/32	.010	3/32
1-7/16"	1-7/16	.010	1/8

EXPLANATION OF CLASS OF SERVICE SYMBOLS

- B Aud** Class-AB or -B Audio Frequency Power Amplifier or Modulator. (Typical operations shown are for two tubes.)
- B TV** Class-B Linear Radio Frequency Power Amplifier. Visual Television Service.
- C CW** Class-C Radio Frequency Power Amplifier and Oscillator. Continuous Wave, Such as for Telegraphy and Frequency Modulated Service.
- AM P1** Amplitude Modulated Radio Frequency Power Amplifier. Plate Modulated or High Level Modulated (Plate and Screen Voltages Modulated).
- Pulse Plate** Pulsed Radio Frequency Power Amplifier. Plate and r-f Excitation Voltages Pulsed.
- Pulse Mod** Pulse Power Amplifier, Modulator, or Keyer Service.

EIMAC TUBES FOR PULSE SERVICES

Eimac tubes, with their "clean" internal construction, ample filament emission reserve, and hard-vacuum, make exceptionally fine pulse modulators, amplifiers, or oscillators. Peak voltages and currents considerably in excess of the published data for continuous operation can be used in pulse work.

Data for specific pulse applications, or our Application Bulletin No. 3 titled "Pulse Service Notes", will be supplied upon request. Our engineering services are also available. Please don't hesitate to call on us; we are anxious to work with you.

Eimac
EITEL-McCULLOUGH, INC.
SAN BRUNO, CALIFORNIA

*Simvac
Tubes*