



# Concertone

MANUFACTURERS OF THE  
WORLD'S FINEST TAPE RECORDERS

*Presents the New*

## SERIES 90

A product of 14 years of excellence in tape recorder manufacture, Concertone's new Series 90 represents a major breakthrough of the finest caliber instruments into the lower-priced equipment field. Designed for rugged reliability under continuous performance conditions the Series 90 meets exacting broadcast requirements as well as those of the finest custom installations for recording studios, industries and audiophiles. Featuring a dynamic new tape transport and advanced electronics, the Series 90 offers the revolutionary new Concertone "Edit-O-Matic" and our exclusive flutter filtering system. Available in monophonic full or half track — stereo 2- or 4-Track versions — the Series 90 brings you the ultimate in professional recorders.



*Concertone's electronic "keyboard" with illuminated mode indicator permits remote operation of the Series 90.*

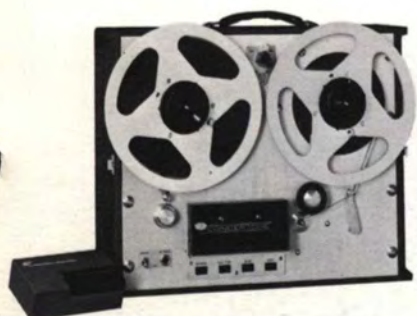

*Available in studio consoles or portable case.  
For vertical or horizontal rack mounting.*

Look at all the professional features to be found in the new Series 90... an instrument that assures recording perfection and versatility unheard of except in the costliest tape recorders.

**INTRODUCING THE CONCERTONE "EDIT-O-MATIC"** The countless advantages of high speed search, cueing and editing are demonstrated in Concertone's exclusive new EDIT-O-MATIC. High speed "SEARCH" enables quick cueing up to the approximate location desired on the tape. A flip of the "CUE" switch brings the tape into contact with the heads and simultaneously releases the brakes for easy manual cueing to the exact spot. A simple "mark and measure" scale pinpoints the precise portion of the tape to be edited.



**EXCLUSIVE CONCERTONE FLUTTER FILTERING SYSTEM** Developed by Concertone, this unique and exclusive system virtually eliminates spurious vibrations and troublesome tape flutter. A dynamically balanced flywheel combined with a viscous damped tape tension arm provides silken-smooth tape handling and recordings virtually free from variations in pitch caused by any components in the tape path.



**STEREO VERSATILITY** Accommodates up to 4 heads for maximum versatility. Stereo Models 93 two-track and 93-4 four-track each contain 4 triple-shielded magnetic heads with playback selector switch allowing user to choose correct stereo playback head for optimum performance. Multichannel erase head provides separate erase for each track affording easy monophonic and sound-on-sound recording.

- Automatic Cut-Off
- Automatic Tape Lifters
- Front Panel Equalization Control
- Cannon Connectors
- Built-in 600 Ohm Output

**2 CHANNEL INPUT MIXER** Separate gain controls for each input signal permit recording from two different sources simultaneously, mixing sounds for proper balance. Optional plug-in transformers provide flexibility in matching input impedances.



**REEL SIZES** Handles all reel sizes from 5" to 10 1/2" with torque adjustment compensating for differences in reel diameter. Torque change switch is mounted on deck front plate for easy accessibility. Changes tension on both supply and take up reels.



**VU METER** Large professional 4 1/4" VU meter with true ballistics calibrated to meet VU standards. Separate selector switch for reading Bias, Record and Output levels. Illuminated face for easy viewing.



- Record Indicator Lights
- A-B Monitoring
- Relay-Solenoid Operation
- Optional Remote Control
- Two- or four-track stereo

## Professional Specifications

<b>Tape Speeds</b>	7.5 — 15 ips or 3.75 — 7.5 ips.
<b>Timing Accuracy</b>	99.8% or better over 1 hour run.
<b>Frequency Response</b>	40 — 15000 cps ±2db at 15 ips. 40 — 12000 cps ±2db at 7.5 ips. 50 — 7500 cps ±2db at 3.75 ips.
<b>Signal-to-Noise Ratio</b>	
Full Track:	55db at 7.5 and 15 ips. 50db at 3.75 ips.
Stereo:	50db at 7.5 and 15 ips. 45db at 3.75 ips.
	Recording a 400 cps signal inducing 2% distortion, erasing the signal and playing back the erased portion of the tape.
<b>Total Harmonic Distortion</b>	Less than 2% at zero VU.
<b>Crosstalk Ratio</b>	50db.
<b>Flutter and Wow</b>	Less than .1% rms at 7.5 and 15 ips. Less than .3% rms at 3.75 ips.
<b>Rewind and Fast Forward</b>	90 seconds for 2400 ft.
<b>Start and Stop Time</b>	.5 second.
<b>Input Impedance</b>	High impedance unbalanced; 50, 250, or 600 ohm balanced or unbalanced with plug-in transformers.

<b>Output Impedance</b>	600 ohm balanced with terminating switch to allow connection to high impedance input.
<b>Output Level</b>	±4dbm at zero VU. Reserve gain to +8dbm.
<b>Dimensions</b>	Transport: 19" x 15 3/4" x 8". Amplifier: 19" x 5 1/4" x 8 1/4".
<b>Weight</b>	Transport: 48 lbs. Amplifier: 12 lbs.
<b>Power Requirements</b>	Monophonic Recorders: Approx. 280w, 115V, 60 cps. Stereo Recorders: Approx. 320w, 115V, 60 cps.



**AMERICAN CONCERTONE, INC.**

A DIVISION OF ASTRO-SCIENCE CORPORATION

9449 West Jefferson Boulevard · Culver City, California  
Telephone: UPTon 0-7245

# AMERICAN CONCERTONE

Price List #900.2  
Effective 4-1/61

DEALER NET PRICE SHEET  
SUPERCEDES ALL PREVIOUS PRICE LISTS

*tape recorders & accessories*

## CONCERTONE SERIES 90 PROFESSIONAL RECORDERS

MODEL	HEAD COMPLEMENT				USER'S NET PRICE	DEALER NET PRICE		
	Head #1 Erase	Head #2 Record	Head #3 Play	Head #4 Play		1-4	5-9	10 or more
91 Full Track Recorder	Full Track	Full Track		Full Track	\$ 845.00	\$591.50	\$549.25	\$507.00
92 Half Track Recorder	Half Track	Half Track		Half Track	\$ 845.00	\$591.50	\$549.25	\$507.00
93 Two Track Stereo Recorder	½ Track Stereo	½ Track Stereo	½ Track Stereo	¼ Track Stereo	\$1095.00	\$766.50	\$711.75	\$657.00
93-4 Four Track Stereo Recorder	¼ Track Stereo	¼ Track Stereo	½ Track Stereo	¼ Track Stereo	\$1095.00	\$766.50	\$711.75	\$657.00
94 Tape Transport Only	Less Heads and Preamplifiers				\$ 480.00	\$336.00	\$312.00	\$288.00







CONVERSION KITS		USERS Net Price	DEALERS Net Price
1.	<u>3.75 - 7.5 ips Operation</u> - - - - - Factory Installed, Specify "A" Following Model Number . . . . .	N/C	N/C
2.	<u>50 Cycle Operation</u> - - - - - Factory Installed, Specify "50 Cycles" Following Model # . . . . .	\$ 35.00	\$ 24.50
3.	<u>Extra Playback Head</u> - - - - - Two Track or Four Track Stereo Head, Factory Installed . . . . .	\$ 65.00	\$ 45.50
4.	<u>Complete Stereo Head Assembly</u> - - - - - Four Heads (Erase, Record, Play, Play) Two or Four Track Stereo, Factory Installed . . . . .	\$195.00	\$136.50

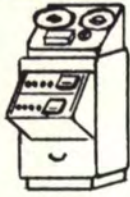

**AMERICAN CONCERTONE**

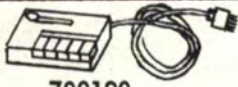
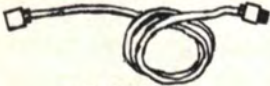
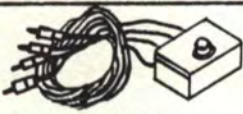
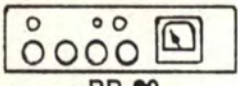
9449 WEST JEFFERSON BOULEVARD, CULVER CITY, CALIFORNIA  
UP 0-7245

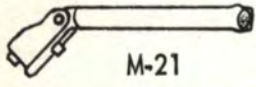
## CONCERTONE SERIES 90 ACCESSORIES

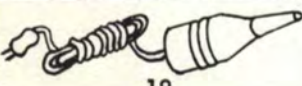
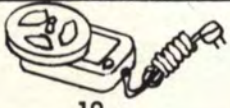
ITEM	CATALOG NUMBER	DESCRIPTION	USERS NET PRICE	DEALER NET PRICE
 700105	700105 700106 700107 700108	Transformer, 50 ohm Microphone, Input Transformer, 250 ohm Microphone, Input Transformer, 10,000 ohm Line-Level, Input Transformer, 600 ohm Line-Level, Input	\$ 29.95 29.95 29.95 29.95	\$ 20.97 20.97 20.97 20.97
 700123	700123	Studio Console Cabinet [All Metal Construction with Separate Turret Mounting for Transport and Preamplifiers.]	225.00	168.75
 700122	700122	Portable Case [For Transport or Two Preamplifiers]	60.00	42.00
 700133	700133	Portable Case [For One Preamplifier Only]	30.00	21.00
 700120	700120	Remote Control [With 8 Ft. Cord]	46.50	32.55
 700121	700121	Remote Control Extension Cord [25 Ft. Cord]	19.95	13.97
 BNCI-C	BNCI-C	Channel Integrator (For Sound-on-Sound Recording)	29.95	20.97
 RP-90	RP-90	Record-Playback Preamplifier (Specify "A" for Channel 1 or "B" for Stereo Conversion)	280.00	196.00
 TST	TST	Tape Strobe Timer	19.00	13.30
 M-21	M-21	Dynamic Microphone, High or Low Impedance	50.00	35.00
 16	16	Microphone Desk Stand	4.00	2.80
 18	18	Head Demagnetizer	5.00	3.50
 19	19	Bulk Eraser	18.00	12.60

All prices F.O.B. factory. TERMS: 2% 10 days; net 30. Prices and specifications subject to change without notice.

AMERICAN CONCERTONE, INC.  
9449 W. Jefferson Boulevard  
Culver City, California

FOR IMMEDIATE RELEASE

AMERICAN CONCERTONE ADDS NEW PROFESSIONAL STEREO TAPE RECORDER  
TO LINE

American Concertone, Inc., a Division of Astro-Science Corporation, is introducing the new Series 90, one of the finest calibre instruments in the lower priced equipment field.

The Series 90 has been designed for rugged reliability under continuous performance conditions and meets exacting broadcast requirements as well as those of the finest custom installations for recording studios, industry and audiophiles.

The Series 90 consists of three models, the Model 91, Model 92 and the Model 93.

The Series 90 features a dynamic new tape transport and advanced electronics, as well as the revolutionary new Concertone "Edit-O-Matic" and the Concertone exclusive flutter filtering system.

For further information consult your nearest Concertone dealer or write the Concertone Factory at 9449 West Jefferson Boulevard, Culver City, California.

# CONCERTONE



# 505

## STEREO RECORDER

*American  
Concertone  
Professional  
Tape  
Recorders*



AMERICAN CONCERTONE PROUDLY ANNOUNCES  
THE ACHIEVEMENT SERIES **505** STEREO  
RECORDER...IN YOUR CHOICE OF 4 TRACK  
OR 2 TRACK RECORD VERSIONS...THE ULTIMATE  
IN SOUND REPRODUCTION...MODESTLY PRICED

# THE CONCERTONE 505

Available as a two, or 4 track recorder, the 505 represents a major achievement in the manufacture of tape recorders...bringing you professional quality sound reproduction in a moderately priced instrument. Starting with a new design that embodies all the exacting features necessary for quality performance, Concertone engineers refined each precision component to *new highs in performance, and new lows in cost.*

**CONCERTONE 505 is a STEREO RECORDER**—brings you the full range of audio frequencies in dynamic stereophonic reproduction. Captures all the fire, the brilliance, the subtle moods and color of the original performance from all sources of sound.

**CONCERTONE 505 is a MONOPHONIC RECORDER**—a single flip of the record selector switch converts the 505 to a single channel recorder enabling you to obtain twice the playing time from your tape.

**CONCERTONE 505 is a SOUND-ON-SOUND RECORDER**—Hours of fun await you in the fascinating world of multiple track recordings. Through the unique concept of erase head and associated circuitry, a single performer can sound like a group merely by re-recording one part on top of another.

**CONCERTONE 505 plays BOTH 2-TRACK and 4-TRACK TAPES**—2 permanently installed playback heads assure perfect head azimuth alignment for optimum frequency response at all times. For 2 channel STEREO and half track MONAURAL playback, a 2 track stereo playback head is used. For 4 track stereo, at either 7½ IPS or 3¾ IPS, a second high quality PB head designed for slow speed, quarter track tapes is used. Separate record and playback heads permit instant monitoring of the taped signal. Compare these outstanding features of the Concertone 505 with units at twice the cost and you will realize this is truly an instrument of professional quality.

DESIGNED TO COMPLEMENT ANY SOUND INSTALLATION

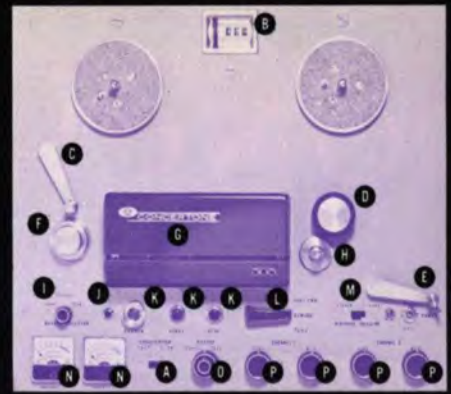

- A EQUALIZATION** permits choice of ideal playback equalization.
- B TAPE LOCATION INDICATOR** permits precise indexing of tape in either direction.
- C TAPE TENSION ARM** permits rapid starting without annoying tape bounce. Eliminates tape irregularities regardless of reel size.
- D CAPSTAN IDLER** Recorder equipped with two precision interchangeable idlers for optimum drive and contact at either speed.
- E AUTOMATIC CUT OFF SWITCH** stops recorder if tape breaks or at end of reel. Also acts as auxiliary tape tensioning device.
- F MECHANICAL FLUTTER FILTER** reduces and filters flutter.
- G AUTOMATIC TAPE LIFTER** reduces tape and head wear during rewind and fast forward modes.
- H CAPSTAN** Quick change precision made sleeves permit choice of speed.
- I RECORD SELECTOR SWITCH** Instantaneous selection of monophonic (either channel) or two channel stereo recording.
- J RECORDING INDICATOR** illuminated only when in "record" mode.
- K PUSH BUTTON CONTROLS** "Feather touch" relay-activated professional type push buttons.
- L FUNCTION SELECTOR** Electrical switching provides easy, instantaneous selection of rewind or fast forward operation with tape automatically lifted.
- M PLAYBACK SELECTOR** allows user to choose correct stereo playback head for optimum performance.
- N LEVEL INDICATORS** Calibrated meters indicate record and playback level.
- O SOURCE TAPE MONITOR** Instant source-tape comparison.
- P RECORDING LEVEL CONTROLS** Each channel has separate line and microphone controls with provision for mixing.

## MODEL 505 HEAD COMPLEMENT



STEREO ERASE	STEREO RECORD	STEREO 2 TRACK PLAYBACK	STEREO 4 TRACK PLAYBACK
-----------------	------------------	-------------------------------	-------------------------------





# THE CONCERTONE

# 505

is precision engineered to close tolerances, incorporating all the latest technological advances in the industry. Only through the quality features incorporated into the 505 can you delight in sound reproduction of such uncompromising fidelity.

## SPECIFICATIONS

<b>HEADS:</b>	Stereo erase, stereo record, two track playback, four track playback
<b>TAPE SPEEDS:</b>	3.75 and 7.5 ips
<b>FREQUENCY RESPONSE:</b>	30-20,000 cps @ 7½ ips. 30-15,000 cps @ 3¾ ips. ± 2 db 50-15,000 cps @ 7½ ips. ± 2 db 50-10,000 cps @ 3¾ ips.
<b>FLUTTER AND WOW:</b>	Less than .2% RMS @ 7½ ips. Less than .25% RMS @ 3¾ ips.
<b>SIGNAL TO NOISE:</b>	—50 db
<b>STARTING AND STOPPING TIME:</b>	0.5 second
<b>REWIND TIME:</b>	45 seconds for 1200 feet
<b>OUTPUT:</b>	Low impedance, cathode follower
<b>INPUTS:</b>	Mike (High impedance) Line (High impedance)
<b>POWER REQUIREMENT:</b>	160 Watts, 115 V AC, 60 cps.
<b>DIMENSIONS:</b>	16¼" wide, 14 ⅛" high, 6¾" deep
<b>WEIGHT:</b>	36 pounds

**A REELING MOTORS, TAKE-UP & SUPPLY**  
Rugged, capacitor type hysteresis motors with provision for torque adjustment.

**B BRAKE ADJUSTMENT** Easily accessible adjust screws with slip-proof tapered lock nuts.

**C BRAKE SOLENOIDS** Heavy duty type, assuring positive dependable action for failproof braking.

**D CAPSTAN DRIVE MOTOR** Precision made, hysteresis, synchronous type for timing accuracy.

**E POWER PACK** Compact, integrated, power pack supplies filtered D.C. for relays & solenoids.

**F CAPSTAN IDLER SOLENOID** permits split-second activation of capstan idler for instant starting.



**G VENTILATOR** High speed fan provides rapid circulation of air for effective ventilation of motors and components.

**H CAPSTAN FLYWHEEL ASSEMBLY.** Dynamically balanced flywheel of large mass for stable operation. Silk belt coupling damps out spurious vibrations affording flutter-free operation.

**I MECHANICAL FLUTTER FILTER** Heavy flywheel (not in view) rotating on ball bearings for maximum stabilization of tape movement.

**J RECORD / PLAYBACK PREAMPLIFIERS**  
Self contained electronics comprising two record and two playback preamplifiers. Separate channels, each with its own bias and equalization adjustments.

### Other Products Manufactured by Concertone

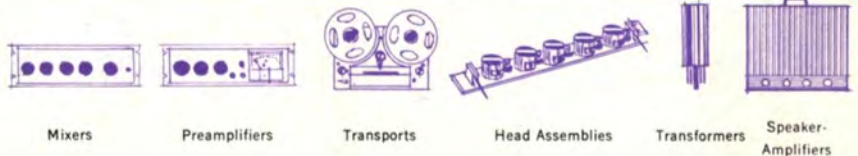

**AMERICAN CONCERTONE, INC.**

A DIVISION OF **ASTRO-SCIENCE CORPORATION**

9449 West Jefferson Boulevard · Culver City, California  
Telephone: UPTon 0-7245

*Through the years, the unmatched standard of excellence in sound reproduction.*

NOW! A HISTORY-MAKING BREAKTHROUGH IN  
STEREO-EXCLUSIVE ON THE FAMOUS 4-TRACK

# CONCERTONE 505 STEREO RECORDER

REVERSE--MATIC

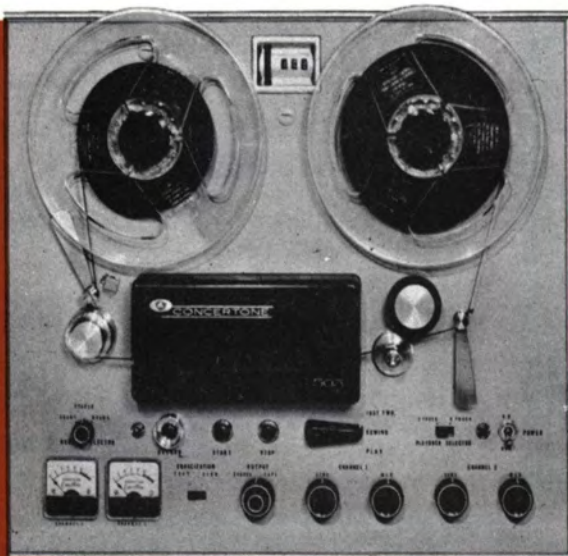

- \* Plays 4-track stereo tape from end to end and back again! No changing reels!
- \* Doubles your listening pleasure!
- \* Doubles unattended playing time!



American Concertone proudly announces another dramatic feature—one that opens new worlds of uninterrupted listening pleasure, one that makes hours of background music a practical reality at home and most business establishments. Now, Concertone Model 505-4R four-track stereo recorder has Reverse-O-Matic, the exciting playback feature that doubles your unattended listening time, doubles your convenience, automatically plays all 4 tracks on your stereo tape—plays it from end

to end and back again. No reversing of reels in the middle of a taped program, no waiting. Reverse-O-Matic back-tracks instantly, automatically!

**GOOD NEWS FOR PRESENT 505 OWNERS**—Your present Concertone 505 2-track or 4-track, can be converted to Reverse-O-Matic Stereo Recorder at your Concertone Service Center.

# CONCERTONE 505



## REVERSE-O-MATIC



### THE ULTIMATE RECORDER THAT BRINGS NEW ADVENTURE IN LISTENING AND RECORDING

Compare the outstanding performance features of the Concertone 505 Reverse-O-Matic—here's a truly professional quality instrument which matches and goes a step beyond units costing twice the price. Perfect flexibility of control makes this the universal recorder—the all-in-one instrument that records any kind of program with perfect fidelity—then plays it back faithfully. Here's what the Concertone 505 Reverse-O-Matic offers:

**REVERSE-O-MATIC**—a revolutionary exclusive, yours on the Concertone 505-4R four-track Stereo Recorder. Plays all four stereo tracks from end-to-end and back again—without interruption, without changing reels. Reverse-O-Matic senses the end of the tape, instantly and automatically switches tracks and plays right back in the other direction. Doubles unattended playing time!

In addition to the exciting Reverse-O-Matic playback feature, the Concertone 505 is the only recorder to offer 3 Hysteresis motors insuring unexcelled recording perfection.

**RECORDS STEREO**—the Concertone 505 Reverse-O-Matic records dynamic 4-track stereo, capturing the full range of audio fre-

quencies. Captures every dimensional nuance from all sources of sound, all the richness and brilliance of the original performance.

**RECORDS MONAURAL QUARTER-TRACK**—with just the flip of a switch the Concertone 505 Reverse-O-Matic converts to record a single channel. This permits you to double your monophonic recording and playing time from a single tape.

**RECORDS SOUND-ON-SOUND**—the new Concertone 505 Reverse-O-Matic permits you to enter the fascinating world of multiple-track, sound-on-sound recording. All controls and associated circuitry permit re-recording. One performance can be recorded on top of another, so a single performer sounds like a group.

For more information about the detailed specifications of the Concertone 505 Reverse-O-Matic ask or write for the complete brochure.



**AMERICAN CONCERTONE, INC.**

A DIVISION OF **ASTRO-SCIENCE CORPORATION**

9449 West Jefferson Boulevard · Culver City, California  
Telephone: UPTon 0-7245

# AMERICAN CONCERTONE

PRICE LIST #505.2-4  
EFFECTIVE 11-15-60

## tape recorders & accessories

DEALER COST PRICE SHEET  
Supersedes all previous price lists

### CONCERTONE MODEL 505 Two and Four Track Stereo Recorders

MODEL	DESCRIPTION	User's Net Price	Quantity Discount			
			1 - 4 34%	5 - 9 38%	10 - 19 40%	20 --- 41%
505	2 Track Stereo Recorder	495.00	326.70	306.90	297.00	292.05
505K	2 Track St. Rec. W/Case	550.00	363.00	341.00	330.00	324.50
505-4	4 Track Stereo Recorder	495.00	326.70	306.90	297.00	292.05
505-4K	4 Track St. Rec. W/Case	550.00	363.00	341.00	330.00	324.50
505-4R	With "Reverse-O-Matic"	579.50	382.47	359.29	347.70	341.91
505-4RK	"Reverse-O-Matic" With Case	634.50	418.77	393.39	380.70	374.36

Model 505 Recorders include 4 heads and contain three (3) hysteresis motors, including hysteresis synchronous drive. All Recorders are dual speed 3.75 - 7.5 ips., 15 - 7.5 ips operation available on special order, add \$25.00 Consumer Net. 50 cycle units available, add \$ 16.50.

### MODEL 505 ACCESSORIES

Catalog Number	Description	User's Net Price	Dealer Cost 30%
13A	Portable carrying case for recorder	\$ 55.00	\$ 38.50
11A	Rack Mount Adaptor, 19" x 16"	20.00	14.00
20A	Cabinet Adaptor, 17-1/2" x 15"	20.00	14.00
BNCI-A	Channel Integrator (for sound-on-sound)	24.95	17.47
M-21	Dynamic Microphone (Hi Z) Omni-Directional	50.00	35.00
16	Microphone Stand	4.00	2.80
50B	Adaptor for 50 cycle operation	10.50	7.35
18	Head Demagnetizer	5.00	3.50
19	Bulk Eraser	18.00	12.60

All prices F.O.B. Factory. Terms: 2% 10 days; net 30. All prices and terms subject to change without notice.



**AMERICAN CONCERTONE, INC.**

9449 WEST JEFFERSON BOULEVARD, CULVER CITY, CALIFORNIA

# AMERICAN CONCERTONE

*tape recorders & accessories*

## Dealer News Letter

### CONCERTONE INTRODUCES THE EXCLUSIVE REVERSE-O-MATIC

The new Concertone Model 505-4R Stereo Recorder with "Reverse-O-Matic" is the freshest, most exciting, new idea to hit the tape recorder market since the introduction of four track stereo. Now for the first time, four track stereo tapes can be played from end-to-end and back again. No reels to turn over, no buttons to push . . . . everything is done automatically.

In order to capitalize successfully on this engineering break-through, Concertone dealers should move quickly to give "Reverse-O-Matic" maximum exposure to their customers. The "Reverse-O-Matic" will virtually sell itself provided a simple demonstration is given to your end user customer. The more demonstrations you make . . . the greater the pay-off in sales and profits.

#### IMPORTANT THINGS TO REMEMBER ABOUT "REVERSE-O-MATIC" IN SELLING YOUR CUSTOMERS:

- 
- . . . . . Plays four track stereo tapes from end-to-end and back again and stops automatically! No reels to turn over!
  - . . . . . Doubles your customer's stereo listening pleasure!
  - . . . . . Doubles unattended listening time!

Concertone is first in its price class with this sensational feature and we have been able to do it only because of our superior three (3) hysteresis motor complement and three (3) solenoid operation. And last but not least . . . the "Reverse-O-Matic" uses two separate four track playback heads, one for each direction of tape movement. There is no head switching or dual function heads.

Order a "Reverse-O-Matic" today and demonstrate it to all of your four track recorder customers. Call in former customers who have purchased inexpensive recorders for a complete demonstration and you will be amazed by the number of your customers who will want to trade up to a Concertone 505-4R "Reverse-O-Matic."



**AMERICAN CONCERTONE, INC.**

9449 WEST JEFFERSON BOULEVARD, CULVER CITY, CALIFORNIA

# CONCERTONE



# 508

## BROADCAST RECORDER

*American  
Concertone  
500 Series  
Professional  
Tape  
Recorders*



AMERICAN CONCERTONE PROUDLY ANNOUNCES  
THE **508** BROADCAST TAPE RECORDER.  
DESIGNED WITH PROFESSIONAL RELIABILITY  
...HANDSOMELY STYLED...MODESTLY PRICED.  
AVAILABLE WITH LOW IMPEDANCE INPUTS  
AND OUTPUTS...MODEL 507 FOR FULL STEREO.



**PORTABLE**



**RACK MOUNT**



**REMOTE**

**ADVANCED DESIGN** The brilliant 508 embodies all the exacting professional features required for broadcast performance. Relay-activated push button control with automatic tape lifters... separate electronics incorporating latest concept in printed circuitry... mixing of microphone and line... low impedance transformers for input and output... classic styling... triple-check quality control.

**PROFESSIONAL RELIABILITY** Rugged tape transport features 3 ultra-quiet hysteresis motors built for maximum timing accuracy, stability of tape movement and years of continuous use. World-famous Concertone heads, precision-engineered to critical tolerances, assure finest performance attainable.

**PROFESSIONAL FIDELITY** Incomparable sound reproduction of the 508 meets the most exacting requirements of the broadcast and recording industry. Dual speeds, full range frequencies, and unique mechanical features match those found only in the costliest instruments.

**OPERATING, TAPE-HANDLING EASE** Dynamically balanced flywheel dampens spurious vibration, assures gentle, flutter-free tape handling. Instant start/stop, "source/tape" output volume control, and "fail-safe", self-energizing brakes enable silken smooth action without tape stretching or fouling.

**CONVENIENT TO USE** Tape transport and separate electronic pre-amplifier are integrated in one lightweight carrying case for easy portability, digital counter and... large illuminated recording meter... monitor facilities in both record and play-back through earphones and/or monitoring equipment... rack mounting via optional accessory... make the 508 the most versatile recorder in its field.

**COMPLETE SERVICE** Immediate supply of factory parts and complete service are backed by a nationwide network of Factory Authorized Service Depots.

## SPECIFICATIONS

<b>Head Complement</b>	Standard with three ½ track or three full track heads. Space for a 4th head.
<b>Reel Size</b>	5" and 7"
<b>Speeds</b>	3¾ - 7½ ips Standard. 7½ - 15 ips available on special order.
<b>Frequency Response</b>	15 ips, 40-15,000 cps ±2db; 7½ ips, 40-12,000 cps ±2db; 3¾ ips, 40-7,500 cps ±2db.
<b>Signal to Noise</b>	55 db Full track; 50 db ½ track at 2% distortion.
<b>Timing Accuracy</b>	99.8%
<b>Wow and Flutter</b>	15 ips, 0.15%; 7½ ips, 0.25%; 3¾ ips, 0.35% RMS.
<b>Fast Transport Time</b>	45 seconds for 1200 feet
<b>Mode Controls</b>	"Feather Touch" push button for start, stop, record. Positive 3 position function selection for play/record rewind-fast forward.
<b>Amplifier</b>	Separate record/play amplifier utilizing printed circuit boards and selected tubes.
<b>Inputs</b>	Separate line and microphone inputs. Lo Z line and/or microphone available with accessory plug-in transformers.
<b>Output</b>	a. Cathode follower 0.5V. b. With accessory transformer 600 ohm balanced or unbalanced (0 dbm full track — minus 4 dbm ½ track or stereo) from program level tapes
<b>Level Controls</b>	Separate microphones and line record level controls for mixing and fading. Source-tape output fader pot for quick "AB".
<b>Meter</b>	VU type meter with separate meter selector switch for source or output during any mode of operation.
<b>Motors</b>	Three — 1 hysteresis synchronous capstan drive and 2 rugged capacitor-type hysteresis torque motors in a most effective indirect drive assembly.
<b>Monitor</b>	Monitor output for phones or line amplifier
<b>Dimensions</b>	Cased: 18" w x 18" h x 11"; Rack: 19" w x 19¼" h x 9"
<b>Weight</b>	Cased: 49 lbs.
<b>Power</b>	160 watts 115V 60 cps; 50 cps available.
<b>Accessories</b>	Carrying case. Input mike XF — 50 or 250 ohm, 600 ohm line input XF, 600 ohm line output, 50 cps transport, 7½ - 15 ips model.



**AMERICAN CONCERTONE, INC.**

A DIVISION OF **ASTRO-SCIENCE CORPORATION**

9449 West Jefferson Boulevard • Culver City, California  
Telephone UPTon 0-7245

DEALER NET PRICE SHEET  
SUPERCEDES ALL PREVIOUS PRICE LISTS

*tape recorders & accessories*

## CONCERTONE SERIES 500 RECORDERS

MODEL	HEAD COMPLEMENT				USERS NET PRICE	DEALER NET PRICE		
	Head #1 Erase	Head #2 Record	Head #3 Play	Head #4 Play		1-4	5-9	10 or more
506 STEREO PLAYER			½ Track STEREO	¼ Track STEREO	\$349.50	\$244.65	\$227.17	\$209.07

[ ABOVE MODELS NOT AVAILABLE WITH CASE ]

507 2-T Stereo Recorder	½ Track STEREO	½ Track STEREO	¼ Track STEREO	½ Track STEREO	\$655.00	\$458.50	\$425.75	\$393.00
507-4 4-T Stereo Recorder	¼ Track STEREO	¼ Track STEREO	½ Track STEREO	¼ Track STEREO	\$655.00	\$458.50	\$425.75	\$393.00
For portable case, specify K following Model #, & add					\$ 60.00	\$ 42.00	\$ 39.00	\$ 36.00

508-1 Full Track Recorder	Full TRACK	Full TRACK		Full TRACK	\$520.00	\$364.00	\$338.00	\$312.00
508-2 Half Track Recorder	Half TRACK	Half TRACK		Half TRACK	\$520.00	\$364.00	\$338.00	\$312.00
For portable case, specify K following Model #, & add					\$ 50.00	\$ 35.00	\$ 32.00	\$ 30.00

CONVERSION KITS		USERS Net Price	DEALERS Net Price
1.	<u>7.5 – 15 ips Operation</u> --- Factory Installed . . . . .	\$ 30.00	\$ 21.00
	Kit only . . . . .	\$ 20.00	\$ 14.00
2.	<u>50 Cycle Operation</u> ----- Factory Installed . . . . .	\$ 16.50	\$ 11.55
	Kit only . . . . .	\$ 10.50	\$ 7.35
3.	<u>Extra Playback Head</u> ----- Two Track Stereo playback		
	Factory Installed . . . . .	\$ 60.00	\$ 42.00
	Four Track Stereo playback		
	Factory Installed . . . . .	\$ 60.00	\$ 42.00







**AMERICAN CONCERTONE**

9449 WEST JEFFERSON BOULEVARD, CULVER CITY, CALIFORNIA

If You Didn't Get This From My Site,  
Then It Was Stolen From...

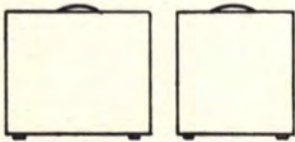
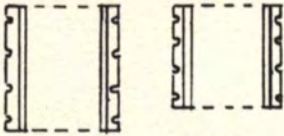
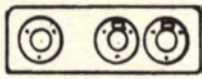

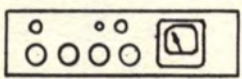
## CONCERTONE SERIES 500 ACCESSORIES

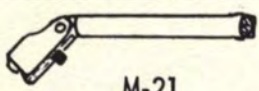
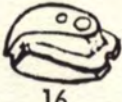
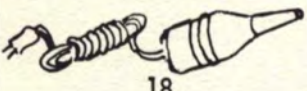
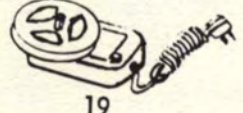
ITEM	CATALOG NUMBER	DESCRIPTION	USERS NET PRICE	DEALER NET PRICE
 700105	700105	Transformer, 50 ohm Microphone, Input	\$ 29.95	\$ 20.97
	700106	Transformer, 250 ohm Microphone, Input	29.95	20.97
	700107	Transformer, 10,000 ohm Line-Level, Input	29.95	20.97
	700108	Transformer, 600 ohm Line-Level, Input	29.95	20.97
	700109	Transformer, 600 ohm Line-Level, Output	29.95	20.97
 700125      700126	700125	Portable Case for Model 507	60.00	42.00
	700126	Portable Case for Model 508	50.00	35.00
 700127      700128	700127	Rack Mount Adapter (Model 507)	23.00	16.10
	700128	Rack Mount Adapter (Model 508)	20.00	14.00
 700129	700129	Cannon Connector Adapter Plate	15.00	10.50
 BNCI-A	BNCI-A	Channel Integrator (For Sound-on-Sound Recording)	24.95	17.47
 RP-50	RP-50	Record-Playback Preamp (Specify "A" for Channel 1 or "B" for Mono and Stereo Conversion)	159.50	111.65
 TST	TST	Tape Strobe Timer	19.00	13.30
 M-21	M-21	Dynamic Microphone, High or Low Impedance	50.00	35.00
 16	16	Microphone Desk Stand	4.00	2.80
 18	18	Head Demagnetizer	5.00	3.50
 19	19	Bulk Eraser	18.00	12.60



All prices F.O.B. factory. TERMS: 2% 10 days; net 30. Prices subject to change without notice.

# AMERICAN CONCERTONE

*tape recorders & accessories*

CONSUMER PRICE SHEET

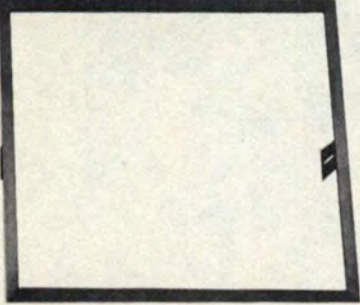
## CONCERTONE MODEL 505 ACCESSORIES

ACCESSORY	DESCRIPTION	FUNCTION	PRICE
 <p>20A-CABINET ADAPTOR</p>	<p>Attractive brushed aluminum picture-frame type adaptor. Dimensions 15" high, 17½" wide.</p>	<p>For easy mounting of Model 505 into cabinets, consoles or custom installations. Vertical or horizontal mountings.</p>	<p>\$ 20.00</p>
 <p>BNCI-A CHANNEL INTEGRATOR</p>	<p>Compact, easy to use, channel integrator equipped with four jacks and four cables. Three position master control switch indicates input and output positions on both channels.</p>	<p>Simplifies sound-on-sound recordings with Model 505. Eliminates interchanging of cables and permits sound-on-sound recordings to be made by using one master control switch.</p>	<p>\$ 24.95</p>
 <p>16-MICROPHONE STAND</p>	<p>Desk stand for Concertone M-21 Microphone.</p>	<p>Permits desk top or conference table recording.</p>	<p>\$ 4.00</p>

SEE YOUR NEAREST CONCERTONE DEALER OR CONSULT YOUR YELLOW PAGES



**AMERICAN CONCERTONE, INC.**



9449 WEST JEFFERSON BOULEVARD, CULVER CITY, CALIFORNIA

# AMERICAN CONCERTONE

CONSUMER PRICE SHEET

*tape recorders & accessories*

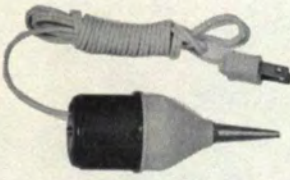
## CONCERTONE MODEL 505 ACCESSORIES

ACCESSORY	DESCRIPTION	FUNCTION	PRICE
 <p>8-HEAD DEMAGNETIZER</p>	<p>Compact and easy to use pencil-type head demagnetizer.</p>	<p>Demagnetizes any tape recorder heads for cleaner recording and reproduction.</p>	<p>\$ 5.00</p>
 <p>19-BULK ERASER</p>	<p>Professional-type bulk eraser. Highly efficient and easy to use.</p>	<p>Erases recorded and unwanted signals and reduces background noise levels below normal erase head. Handles all reel sizes up to 10½". Professional quality, precision engineered.</p>	<p>\$ 18.00</p>
 <p>TAPE TIMER-STROBE</p>	<p>Precision-made timing instrument measuring minutes and seconds. Chrome-plated with resetting device. Built-in strobe.</p>	<p>For determining accuracy of tape speed. Uses dial and features strobe for instant visual speed check. Times length of tape in minutes and seconds.</p>	<p>\$ 19.00</p>

SEE YOUR NEAREST CONCERTONE DEALER OR CONSULT YOUR YELLOW PAGES



**AMERICAN CONCERTONE, INC.**



9449 WEST JEFFERSON BOULEVARD, CULVER CITY, CALIFORNIA

# AMERICAN CONCERTONE

*tape recorders & accessories*

CONSUMER PRICE SHEET

## CONCERTONE MODEL 505 ACCESSORIES

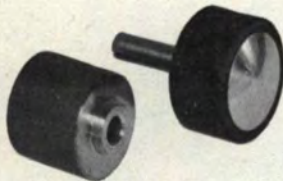
ACCESSORY	DESCRIPTION	FUNCTION	PRICE
 M-21 MICROPHONE	All-directional 'Slimair' dynamic microphone. Wire mesh blast-filter. 90° swivel. 150 ohm or high impedance. Output -58 db. On-off switch.	For P.A. use and tape recording of individual and group singers and speakers, choirs and orchestras.	\$ 50.00
 50B-ADAPTOR FOR 50 CYCLE OPERATION	Machine-tooled motor pulley adaptor. Slips on Model 505 drive motor shaft.	Installation of this simple adaptor permits model 505 to be used in foreign countries where 50 cycle operation is standard.	\$ 10.50
 715-ADAPTOR FOR 15 IPS OPERATION	Combination Capstan bushing sleeve and precision-made rubber pressure roller, both installed from front panel of recorder.	Converts standard 3 3/4-7 1/2 ips operation of Model 505 to 15 ips to satisfy professional requirements.	\$ 25.00

SEE YOUR NEAREST CONCERTONE DEALER OR CONSULT YOUR YELLOW PAGES



**AMERICAN CONCERTONE, INC.**

9449 WEST JEFFERSON BOULEVARD, CULVER CITY, CALIFORNIA

# AMERICAN CONCERTONE

CONSUMER PRICE LIST

*tape recorders & accessories*

## CONCERTONE MODEL 505 ACCESSORIES

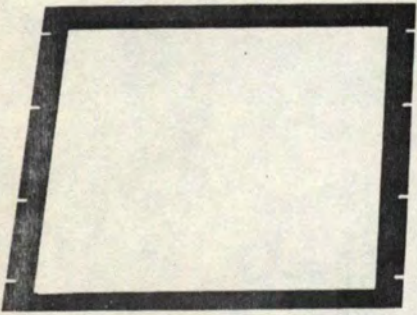
ACCESSORY	DESCRIPTION	FUNCTION	PRICE
 <p>13A CARRYING CASE</p>	<p>Rugged, lightweight all-magnesium carrying case with vinyl covering. Matches Model 250 case.</p>	<p>Permits on-the-spot or remote recording with Model 505. Also attractively styled for interior installations</p>	<p>\$ 55.00</p>
 <p>11A RACK MOUNT</p>	<p>Professional gray aluminum picture-frame type adaptor. Dimensions 15-3/4" high, 19" wide.</p>	<p>For easy mounting of Model 505 into standard professional broadcast racks. Vertical or horizontal mounting</p>	<p>\$ 20.00</p>

For Further Information See Your Nearest Concertone Dealer or Consult Your Yellow Pages.



**AMERICAN CONCERTONE, INC.**

9449 WEST JEFFERSON BOULEVARD, CULVER CITY, CALIFORNIA

# AMERICAN CONCERTONE

PRECISION MAGNETIC TAPE RECORDER / REPRODUCERS

General Specification:

Model C-540-1

Background Music Tape Player

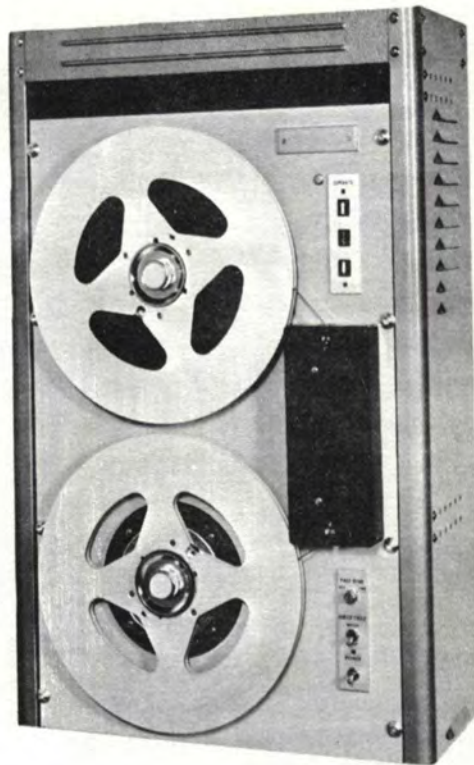

## General Description:

The Background Music Magnetic Tape Transport Model C-540-1 was designed to reproduce Background Music previously recorded on 1/4" magnetic tape on 10 1/2" or 14" reels. The transport may function in one of two ways. (1) Single cycle operation, which consists of playing an entire track in one direction automatically reversing and playing the other track to the opposite end of the tape and stopping. (2) Continuous operation, the machine repeats continuously the single cycle operation, without stopping, until switched off. A total of 8 hours of non-repetitive program material can be played when using 14" reels at a tape speed of 3 3/4 ips.

## Applications:

The Model C-540-1 was specifically designed as a background music tape player, but may be used as a playback device for automatic check-out devices etc. and may be provided with record facilities.



**AMERICAN CONCERTONE, INC.**

A DIVISION OF **ASTRO-SCIENCE CORPORATION**

9449 West Jefferson Boulevard · Culver City, California

Telephone: UPTon 0-7245

## Dimensions:

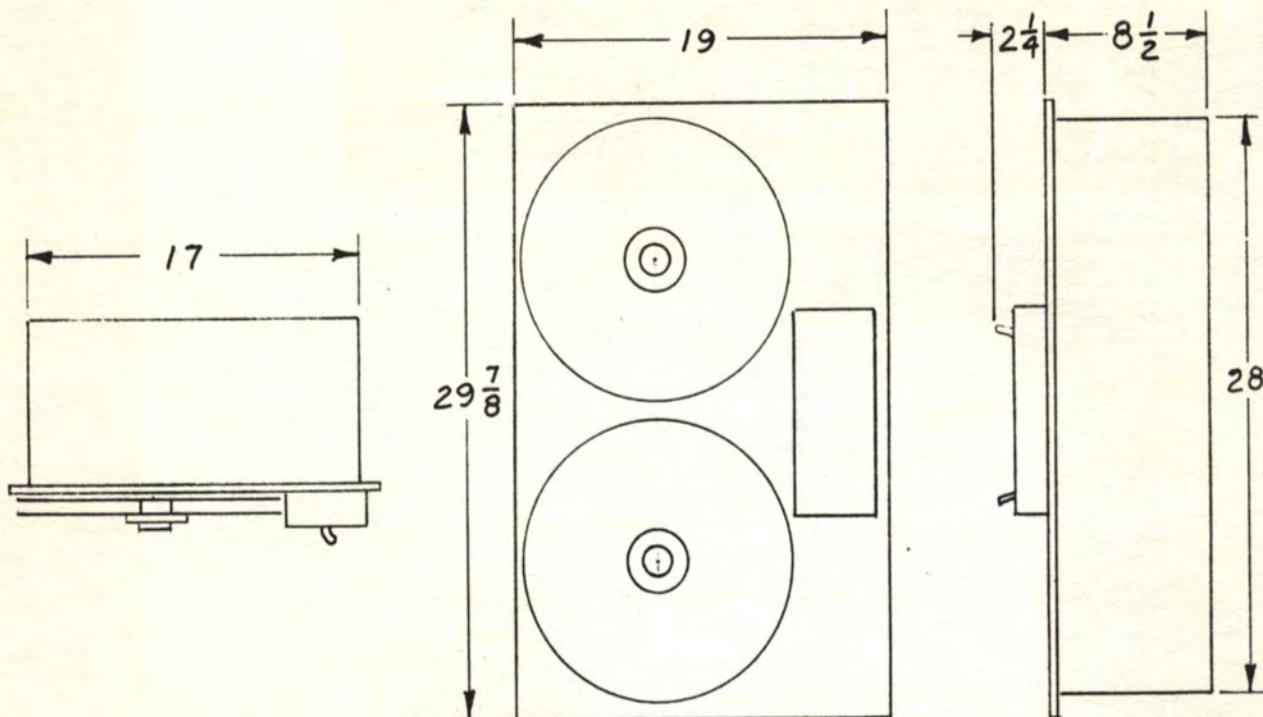

## Specifications:

<b>Reel Size:</b>	Up to and including 14" reels with the standard NAB hub
<b>Tape Width:</b>	$\frac{1}{4}$ "
<b>Heads:</b>	Two half-track playback heads
<b>Motors:</b>	Two induction reeling motors, one hysteresis-synchronous capstan motor.
<b>Frequency response:</b>	50 to 7,500 cps $\pm$ 3 db at $3\frac{3}{4}$ ips.
<b>Signal to noise ratio:</b>	45 db or better
<b>Tape Reversing mechanism</b>	Uses metal foil applied to the oxide side of the tape, reverses in less than 2 seconds. Indicator lights provide visual indication of the direction of tape travel.
<b>Mounting:</b>	Transport is slotted to permit mounting in standard 19" equipment racks.

**Note:** The purpose of this specification is to describe a typical piece of equipment that American Concertone has designed and manufactured for a specific application.

Since American Concertone specializes in producing equipment to customer order for specific requirements, contact us for information on how this equipment may be modified or similar equipment may be designed to suit your needs.

Specifications subject to change without notice

# Concertone

WORLD'S FINEST TAPE RECORDERS



## *The exciting new Series 90 professional tape recorders*



The advanced Series 90, created in the tradition of quality established by the famous Series 30, satisfies the most critical needs of the professional and audiophile. New exclusive Concertone features such as "Edit-o-matic" for high speed tape cueing and editing...exclusive Flutter-Filtering System...combine with the maximum in wide stereo-mono versatility and automatic-remote capabilities...to make the sophisticated Series 90 the most complete and distinguished-performing instrument yet attained. From \$845.

## *World famous 505 - unequalled stereo performance*

The superb Concertone 505 brings you professional reproduction plus unlimited versatility. Available as a 2- or 4-track recorder, and now with exclusive Reverse-O-Matic® permitting 4-track stereo tapes to be played from end to end and back again - unattended. From \$495.



## *Transicorder - the DeLuxe miniature tape recorder*



"Book size" - all-transistorized - the Concertone Transicorder has big tape recorder features in precision-made miniature form. Lightweight, under 4 lbs., the Transicorder fits in a brief case or glove compartment - yet offers amazing fidelity for on-the-spot recordings anywhere - at home, office or travel. \$169.95.

## *New 500 Series - professional quality, modest price*

Incorporating today's most advanced recorder design with professional reliability, extreme fidelity and tape-handling ease, the brilliant 500 Series has no equal for flawless broadcast performance or custom installation. 3 silent, heavy-duty hysteresis motors assure maximum timing accuracy, tape stability and years of use. Triple shielded heads afford incomparable sound reproduction. Available as a precision tape player or with separate electronics to be added for mono or stereo record and playback applications - Concertone's new 500 Series is matched only by the costliest instruments. From \$349.50.



At Better Dealers Everywhere

See **CONCERTONE**

at your dealer. Mail

coupon for

name of nearest

dealer and

complete information.

Dealer inquiries invited.



### **AMERICAN CONCERTONE, INC.**

A DIVISION OF **ASTRO-SCIENCE CORPORATION**  
9449 West Jefferson Boulevard • Culver City, California

Please send detailed information on **CONCERTONE**

Series 90  505 Stereo Recorder  Transicorder   
Reverse-O-Matic  Series 500

Name \_\_\_\_\_

Address \_\_\_\_\_

City \_\_\_\_\_ Zone \_\_\_\_\_ State \_\_\_\_\_



# Look First to Concertone

FOR YOUR MILITARY AND INDUSTRIAL RECORDER NEEDS\*

American Concertone, the pioneer producer of quality magnetic recorders for the military and industry, has developed a series of basic recorder/reproducers and transports which can rapidly be modified for a wide range of military and industrial magnetic tape applications. These versatile high-performance units may be combined in many ways to economically and rapidly meet the exacting requirements of your system or application. Whatever your project in communications, data handling or instrumentation, if quality tape handling is required, you can confidently turn to the Concertone engineers for assurance of economical solution, on-target performance and maximum reliability ■ For either a bid or an analysis of your requirements, please contact Frank Bumb, Vice President, Engineering. For illustrated brochure, please write Dept. SAN 161



**AMERICAN CONCERTONE, INC.**

A DIVISION OF **ASTRO-SCIENCE CORPORATION**

9449 West Jefferson Boulevard · Culver City, California

Telephone: Upton 0-7245



14-INCH REEL BI-DIRECTIONAL TAPE PLAYER

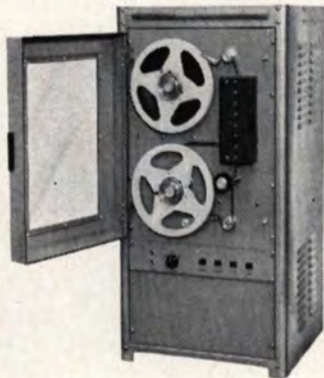

MULTI-SPEED ANALOG TAPE TRANSPORT

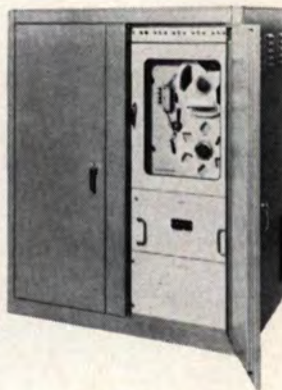

MACHINE TOOL CONTROL TAPE TRANSPORT



SERIES 90, 3-SPEED, 2 OR 3-CHANNEL RECORDER FOR BROADCAST AND INDUSTRIAL APPLICATIONS



SLOW SPEED DIGITAL TAPE READER WITH 30 IPS FORWARD AND REVERSE SEARCH, COMPATIBLE WITH IBM TAPES



NARROW BAND PULSE-CODE RECORDER/REPRODUCER



SPECIAL PURPOSE TAPE TRANSPORT USING 1-INCH TAPE ON 8-INCH REELS



AIRBORNE OR MOBILE RECORDER WITH TRANSISTORIZED RECORD/REPRODUCE AMPLIFIERS



VARIABLE LENGTH, CONTINUOUS LOOP RECORDER/REPRODUCER WITH TRANSISTORIZED AMPLIFIERS



HEART OF CONCERTONE'S MARK IV DIGITAL TAPE HANDLER

*\*Concertone is proud of its reputation among its industrial and military customers as one of the recorder industry's most competitive bidders.*

Introducing..... **THE NEW**.....



**STEREO PLAYER**

**MODEL 201**



Ideal as your first step to stereo tape enjoyment ... or as a companion to your stereo recorder for tape copying use .... The **GALAXY** Model 201 plays two or four track stereo tapes as well as full or half track .... at either  $3\frac{3}{4}$  or  $7\frac{1}{2}$  ips

Available in two models ..... the 201 or 201A (includes built-in preamplifier) ..... The **GALAXY** Stereo Player offers you the finest stereo reproduction, modestly priced.

**GALAXY**

**MODEL 201 ..... \$84.50**

**MODEL 201A ..... \$159.50  
(with preamp)**

# GALAXY STEREO PLAYER

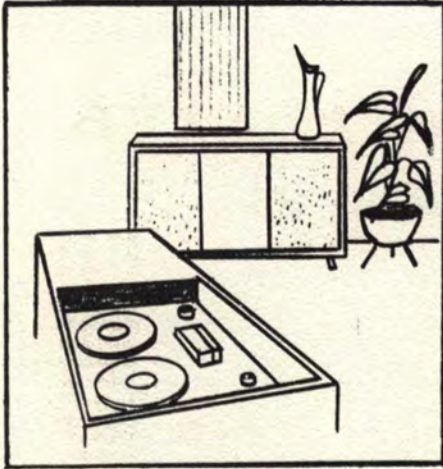

**PRESENT SYSTEMS**

Designed for installation into your present hi-fi system for low-cost, high quality stereo tape enjoyment.

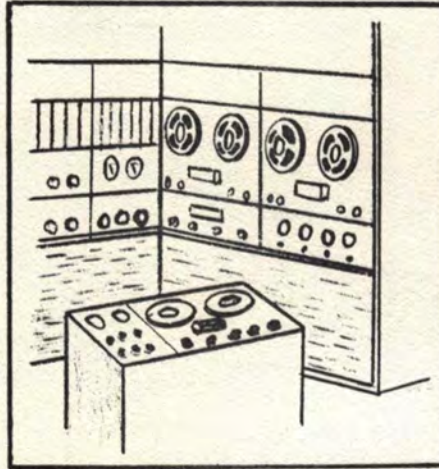

**TAPE COPYING**

A companion to your stereo recorder. Use the GALAXY to make stereo tape copies for your friends.



**NEW SYSTEMS**

Ideal for new systems, the GALAXY integrates easily with basic components.

## SPECIFICATIONS 201 AND 201A

### MODEL 201

Tape Speed . . . . .	3.75 - 7.5 ips
Reel Size . . . . .	3", 5", or 7"
Wow and Flutter . . . . .	Better than .30% RMS at 7.5 ips
Timing Accuracy . . . . .	99.5% (Hysteresis-synchronous Drive)
Frequency Response . . . . .	
When connected to a suitable tape head input of a stereo preamplifier, will have response characteristics similar to the 201A	
Signal to Noise . . . . .	50 db at 7.5 ips 46 db at 3.75 ips
Power . . . . .	117 VAC, 60 cycles, 26 watts
Weight . . . . .	14.5 lbs
Dimensions . . . . .	Height 6-3/8" Width 14-1/2" Depth 10-3/8"
Output . . . . .	1.5 V

### MODEL 201A

Tape Speed . . . . .	3.75 - 7.5 ips
Reel Size . . . . .	3", 5", or 7"
Wow and Flutter . . . . .	Better than .30% RMS at 7.5 ips
Timing Accuracy . . . . .	99.5% (Hysteresis-synchronous Drive)
Frequency Response . . . . .	7½ - 40 - 12,000 cps (Down no more than 3 db at 15 kc) 3¾ - 40 - 8,500 cps (Down no more than 3 db at 10 kc)
Signal to Noise . . . . .	50 db at 7.5 ips 46 db at 3.75 ips
Power . . . . .	117 VAC, 60 cycles, 26 watts
Weight . . . . .	16 lbs
Dimensions . . . . .	Height 6-3/8" Width 14-1/2" Depth 10-3/8"

# GALAXY

9449 West Jefferson Boulevard · Culver City, California  
Telephone: UPTon 0-7245

DEALER COST PRICE SHEET

All Prices Subject to Change without Notice

GALAXY STEREO PLAYER

MODEL	DESCRIPTION	User Net Price	Dealer Net Price		
			1 - 2	3 - 5	6 - More
TP-201	STEREO PLAYER - Two or four track stereo playback Less Preampfier	\$ 84.50	59.00	55.00	51.10
TP-201A	STEREO PLAYER - Two or four track stereo playback <u>Includes Transistorized Stereo Preampfier</u>	159.50	112.00	104.00	95.62

All Model TR-201 and TP-201A STEREO PLAYERS operate at 3-3/4 - 7-1/2 ips. All players contain a stereo playback head and a track selector for two or four track stereo tapes.  
All Model P-201 and TP-201A STEREO PLAYERS contain a hysteresis-synchronous drive motor.

ITEM NUMBER	ACCESSORIES	User Net Price	Dealer Net Price
AM-201	Transistorized Stereo Preampfier..... (For Model TP-201 - Playback Only)	\$ 69.95	\$ 48.80
18	Head Demagnetizer .....	5.00	3.50
19	Bulk Eraser .....	18.00	12.00

SHIPPING: All shipments will be made via best and cheapest way.  
Drop shipments will be made at discretion of the Factory.

TERMS: 2% 10 days -- Net 30 days from date of invoice. All prices F.O.B. Factory.  
2% for cash discount applies to current open accounts, not C.O.D., or Proforma Invoices.

GALAXY

9449 West Jefferson Boulevard, Culver City, California  
VERMONT 9-7568 - UPTON 0-7245

CONCERTONE QUALITY SUPPORTED BY .....

- . PUBLICITY RELEASES
- . GLOSSY PHOTOS
- . AD MATS



POINT-OF-SALE MATERIAL

- . EASEL CARDS
- . WINDOW STREAMERS
- . WIRE BANNERS



LITERATURE

- . BROCHURES ON ALL CONCERTONE PRODUCTS
- . SPEC SHEETS
- . PRICE SHEETS FOR CONSUMER AND DEALER

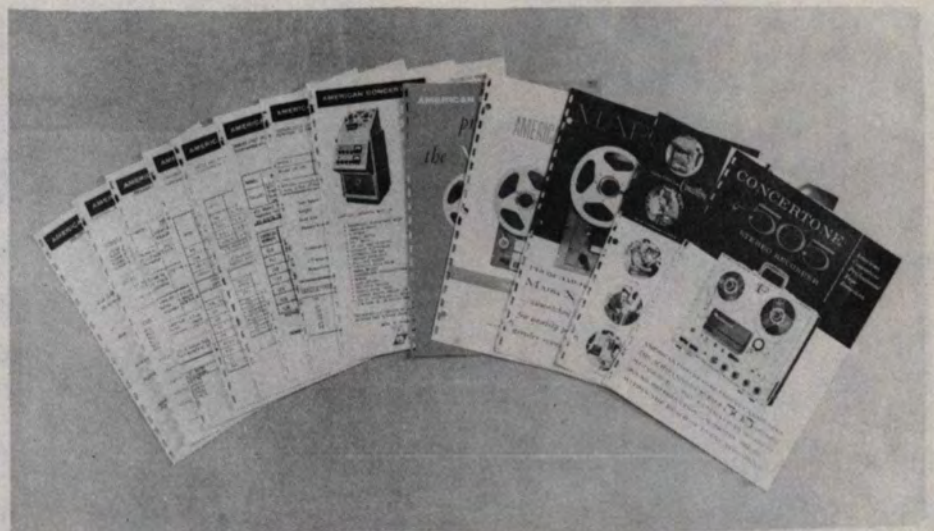

OUTSTANDING EXAMPLES OF  
ADVANCED *Concertone Quality* FEATURES

to help you sell

PROFESSIONAL SPECIFICATIONS - Far advanced design, ultra-critical component standards and unfailing reliability enable Concertone to meet the highest professional specifications. Years of continuous use by recording studios and broadcast stations testify to the professional standards built into all Concertone instruments.

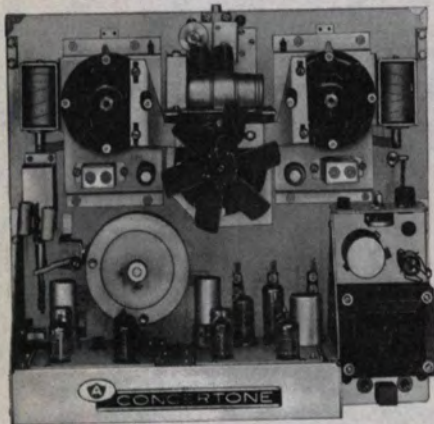

MOTORS

MOTORS - Hysteresis synchronous capstan motor... rugged ultra quiet hysteresis reeling motors... are built for years of continuous use. Precision engineering to tolerances of 2 millionths of an inch serves to make Concertone drive systems the most dependable and longest-lasting known.

---

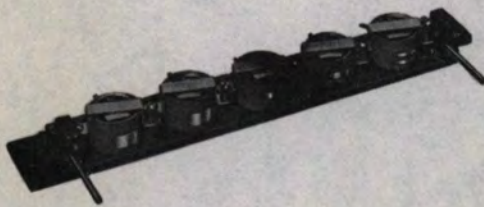

HEADS

HEADS - World famous Concertone heads, brilliantly designed and manufactured to microscopic tolerances guarantee the finest performance attainable. Separate heads are used for each function - record, playback, and erase. Unique Concertone heads show negligible wear even after thousands of hours of operation.

TAPE HANDLING - Concertone handles tape more gently than any other recorder. Dynamically balanced flywheels assure super-smooth, flutter-free, faster tape handling. Self-energizing, silken-smooth, brake action enables fast stopping without tape stretching.

CONCERTONE QUALITY - in each component part makes strong selling points.

# AMERICAN CONCERTONE

C-540-1  
Dealer Cost Sheet  
Effective 2-17-61

*tape recorders & accessories*

## DEALER COST SHEET

Model	Description	User's Price	QUANTITY DISCOUNT		
			30% 1 - 3	35% 4 - 7	8 or more
C-540-1	Background Music Tape Player	\$695.00	\$486.50	\$451.75	Contact Factory

### SPECIFICATIONS:

<u>Reel Size:</u>	Up to and including 14" reels with NAB hub.
<u>Heads:</u>	Two half-track playback heads.
<u>Motors:</u>	Two induction reeling motors, one hysteresis-synchronous capstan motor.
<u>Fast Wind:</u>	Less than 5 minutes for 14" reel. Automatic tape lifter.
<u>Brakes:</u>	Self-energized.
<u>Electronics:</u>	Playback pre-amplifier produces frequency response of from 50 to 7500 cycles $\pm$ 3 db at 3-3/4 ips.
<u>Output:</u>	Cathode follower 2 volts nominal.
<u>Reversing Mechanism:</u>	Uses metal foil applied to the oxide side of the tape, reverses in less than two seconds. Indicator lights provide visual indication of the direction of tape travel.
<u>Power Required:</u>	115 VAC, 60 cycle, 160 watts maximum.
<u>Mounting:</u>	Transport is slotted to permit mounting in standard 19" equipment rack. Equipped with protective metal enclosure and AC power cord interlock.



**AMERICAN CONCERTONE, INC.**

9449 WEST JEFFERSON BOULEVARD, CULVER CITY, CALIFORNIA

If You Didn't Get This From My Site,  
Then It Was Stolen From...

[www.SteamPoweredRadio.Com](http://www.SteamPoweredRadio.Com)