

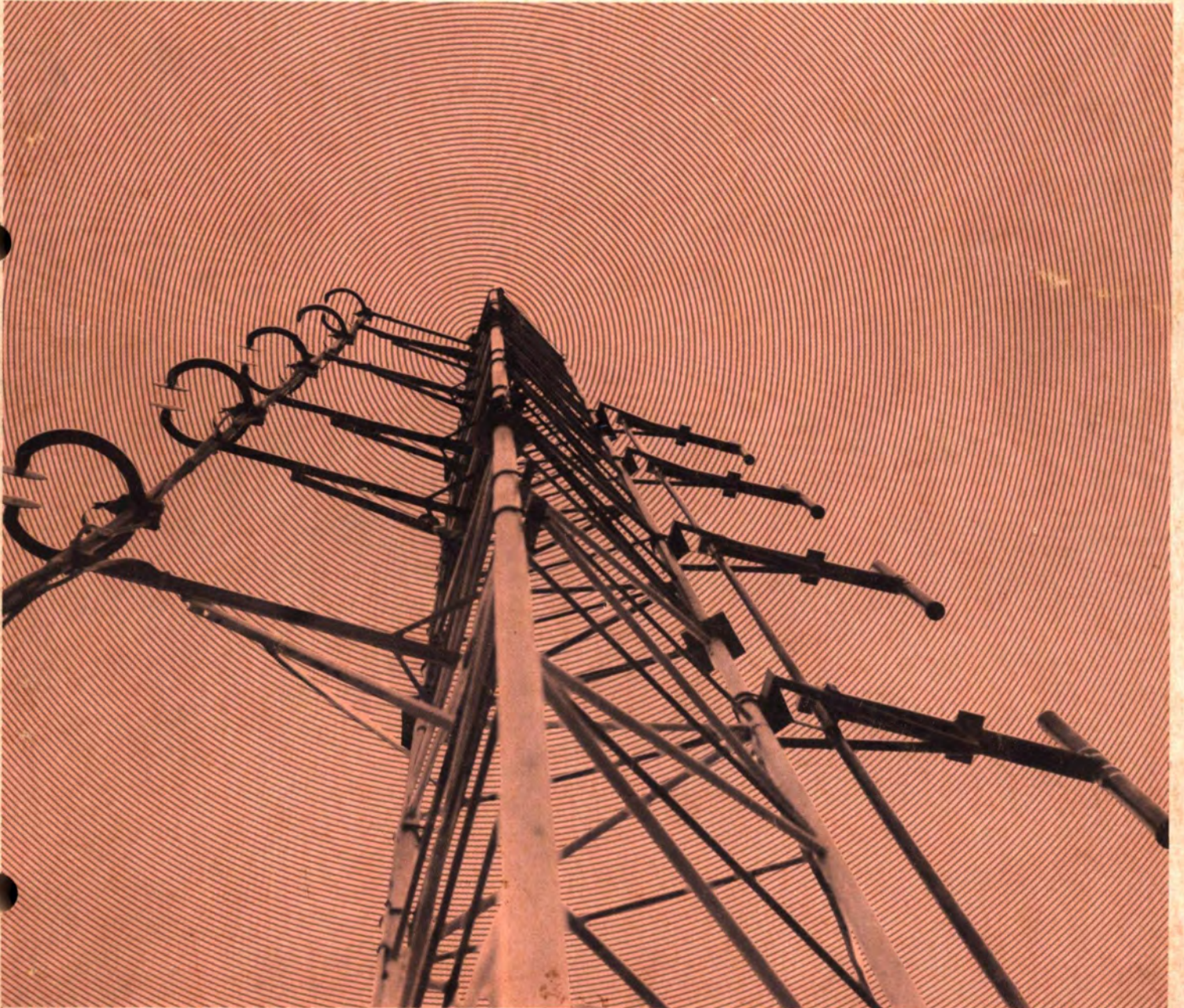

BROADCAST EQUIPMENT



COLLINS BROADCAST EQUIPMENT

TABLE OF CONTENTS:

AM Transmitters	2	Tape Equipment	109
Phasing	12	Microphones	121
FM Transmitters	17	Studio Accessories	124
Antennas	32	Measuring, Monitoring	135
Towers	35	Remote Control	142
Transmission Lines	38	STL Microwave	143
Audio Facilities	92	Tables, Charts, Graphs	145
Disc Equipment	102	Indices	164

Collins Sales Policy is found at the back of this catalog.

Equipment descriptions in this catalog are necessarily condensed so that the complete line of broadcast units supplied by Collins Radio Company could be shown. For more information on any of these units, you are invited to contact your Collins Broadcast Sales Engineer or Collins Radio Company, Broadcast Communication Division, Dallas, Texas.



The reputation of Collins Radio Company has been built on more than a quarter of a century of research, development and manufacture of distinctive electronic equipment. To assure broadcasters of the very finest equipment, Collins engineers and technicians follow without exception this company-wide philosophy:

Design and build equipment based on technical ingenuity, unique function and quality of craftsmanship, rather than solely on the grounds of price and sales effort.

Whatever the field — broadcast, amateur radio, aviation electronics, military or industrial communication, or space communication—Collins adheres strictly to its basic code that there is no substitute for quality.

Collins research and development, its staff of highly competent field technicians and the Company's never ending stress on quality control assure each Collins broadcast equipment owner that he has the most advanced, thoroughly tested equipment available, and that it will retain its value through the years.

In this catalog is the latest equipment of the complete broadcast line that has earned Collins its unparalleled reputation in the field. Collins famous quality and reliability are integral parts of all these units.

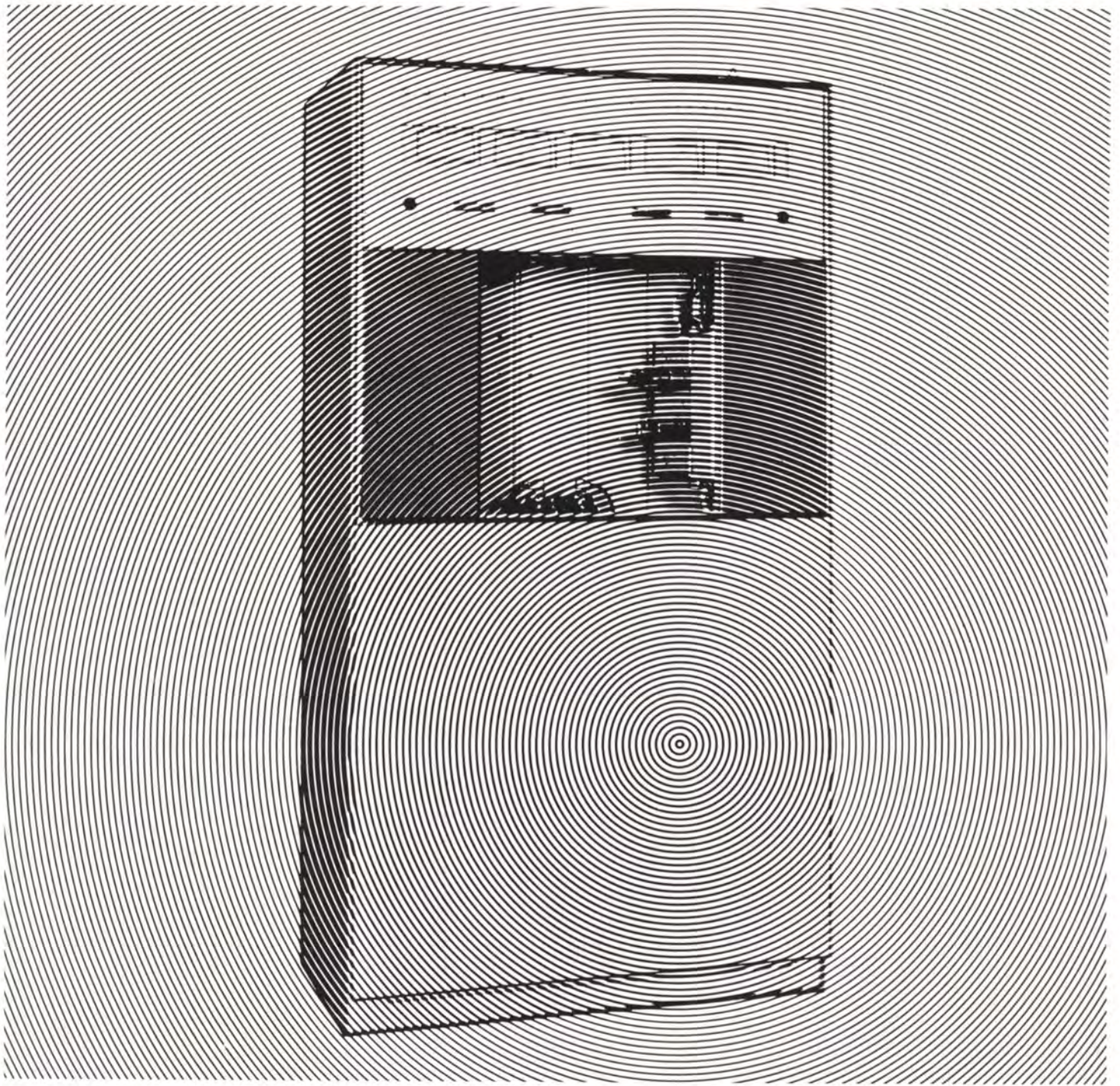

AM TRANSMITTERS AND PHASING

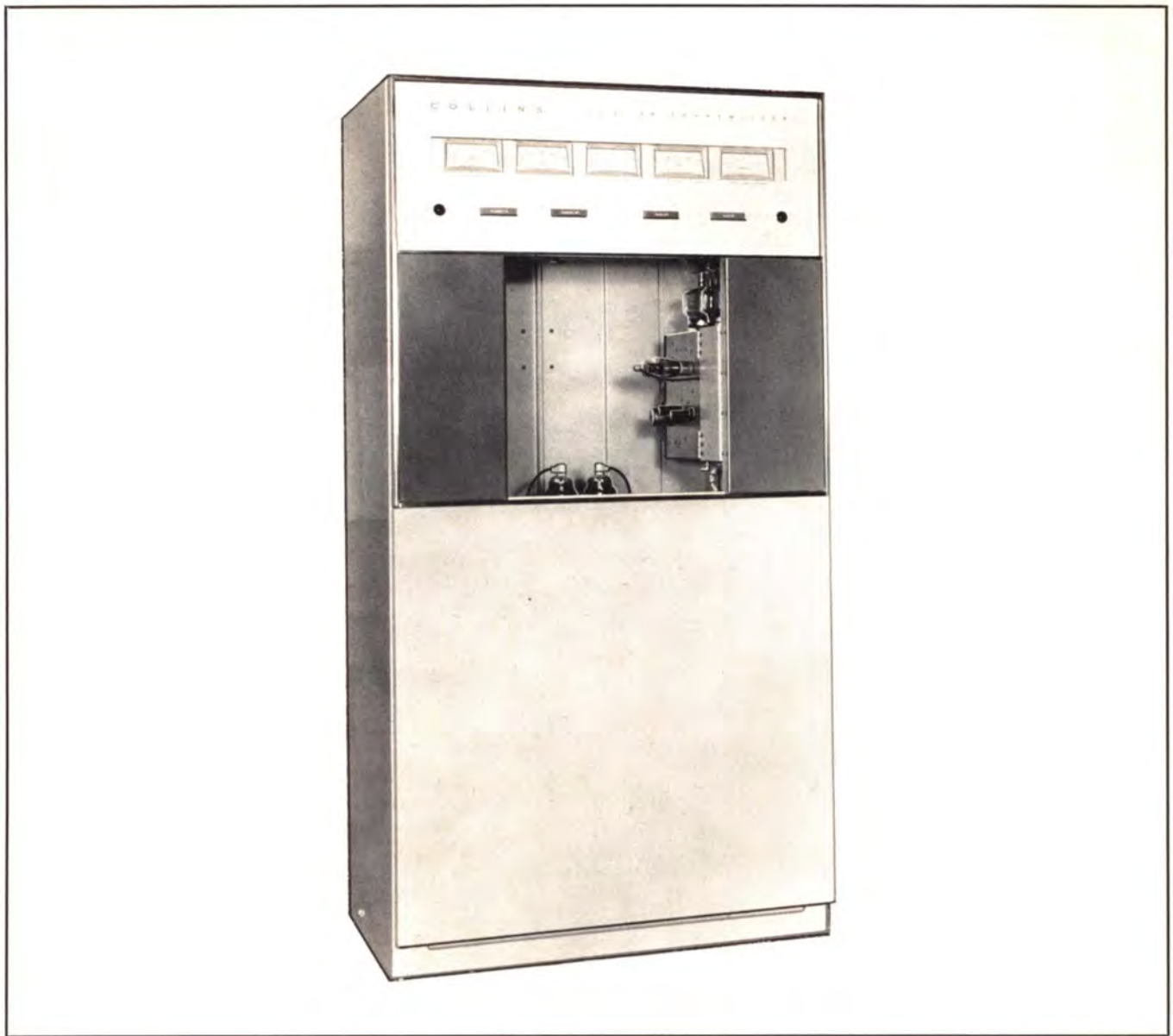

COLLINS 20V-3 1,000/500/250-WATT AM TRANSMITTER

The Collins 20V-3 1,000/500/250-watt AM transmitter, designed for reliable, high fidelity broadcasting at any specified frequency from 540 to 1600 kc or in any of the high frequency broadcast bands up to 12 mc, has many features that make it one of the most advanced transmitters on the market.

The bold, clean-cut styling of the cabinet is in keeping with the modern design of the transmitter circuitry. Streamlined, brushed chrome trim and white meters add to the attractive appearance of the cabinet, which is finished in a high gloss gray, blue-gray and off-white baked enamel. The cabinet and circuitry provide unparalleled accessibility for operation, maintenance and inspection.

The RF and audio chassis swing out and the power supply tilts up so that all components are exposed. Mounted on the RF and audio chassis are quiet, high capacity

blowers which force air directly on the tubes to give an extra assurance of long tube life.

Pushbutton control of filament and plate power is provided and may be extended to a remote position. Automatic sequencing of the power control circuits is incorporated. Filament voltage control and power circuit controls may be adjusted while the transmitter is operating.

A typical stability of ± 2 cps is attained by using a highly perfected oscillator design in conjunction with very stable, low temperature coefficient crystals — a concept pioneered by Collins to eliminate the troublesome crystal oven.

Thermal time delay circuitry selects the optimum time interval before the transmitter can be returned to the air after a power line failure. After an instantaneous power interruption the carrier can be returned to the air

immediately, cutting off-the-air time to a minimum. Overload relays are adjustable and are provided for the RF driver, audio driver, power amplifier and modulator stages. These relays are connected so that an overload removes plate power and the equipment must be re-energized manually.

The 20V-3 power supplies are heavy duty and conservative. One high voltage power supply is used for the modulator and final amplifier. A separate low voltage supply feeds the modulator screen grids, as well as the plates and screen grids of the other RF and audio tubes. Bias supply provides voltages for the modulator, power amplifier and other biasing throughout the transmitter.

The Collins 20V-3 uses four, Type 4-400A tetrodes in the modulator and final amplifier. The use of the 4-400A tetrodes is another concept pioneered by Collins and now widely accepted as the best in transmitter design.

Frequency Range: 540-1600 kc standard. Frequencies to 12 mc available.

Power Output: 1,000/500/250 watts.

Frequency Stability: Better than ± 5 cps. (Typical—Better than ± 2 cps.)

Audio Frequency Response: Within ± 2 db, 50-10,000 cps.

Audio Frequency Distortion: Less than 3%, 50-7,500 cps up to 95% modulation level. (Typical—Less than 3%, 30-15,000 cps.)

Residual Noise Level: 60 db or better below 100% modulation.

Carrier Shift: Less than 3%, 0-100% modulation. (Typical—Less than 2%.)

RF Output Impedance: 50-70 ohms unbalanced. Others, including balanced, available on order.

Audio Input Impedance: 150/600 ohms balanced.

Audio Input Level: +10 dbm, ± 2 db.

Power Source: 208-240 v ac, single phase 50/60 cps.

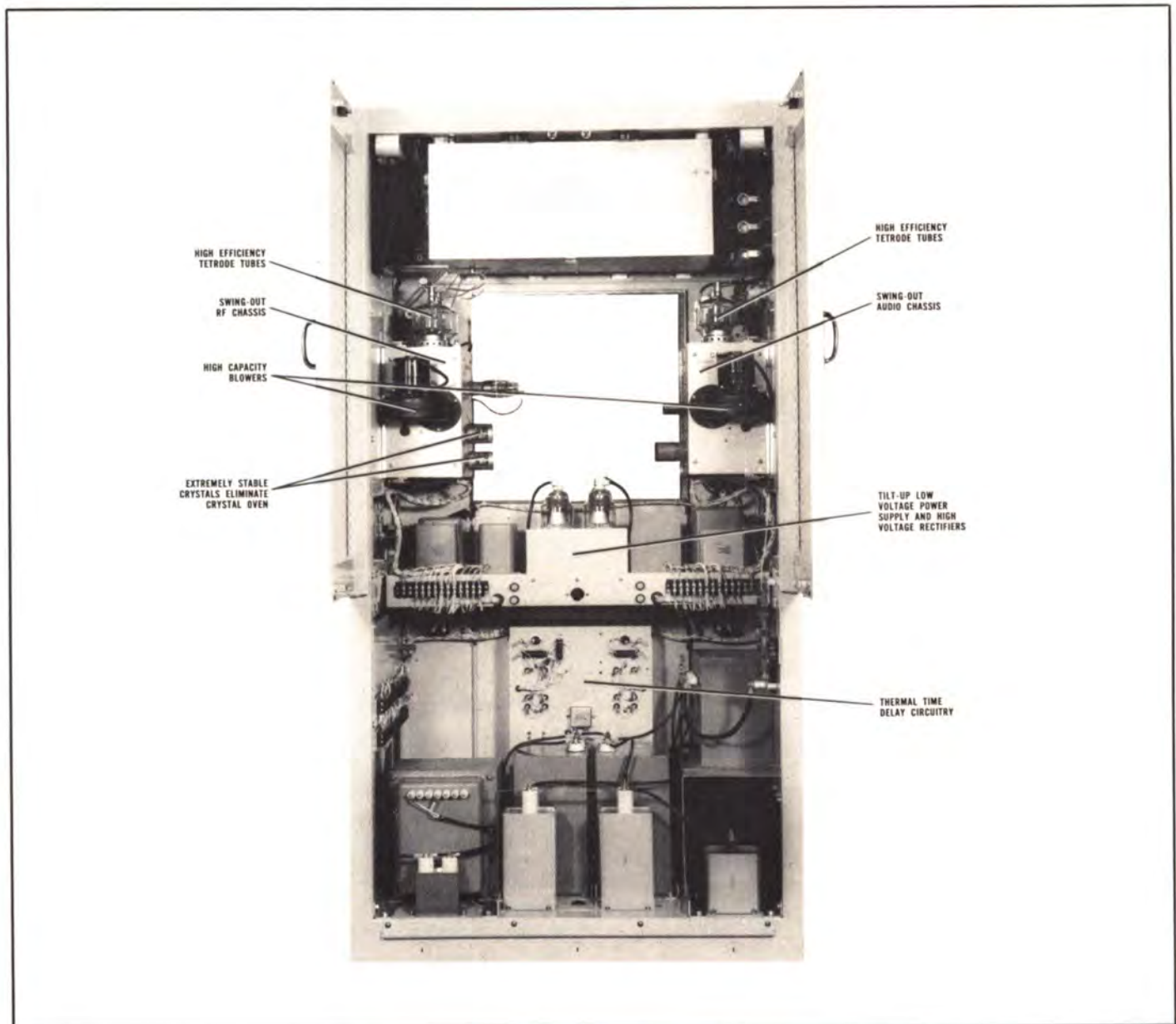

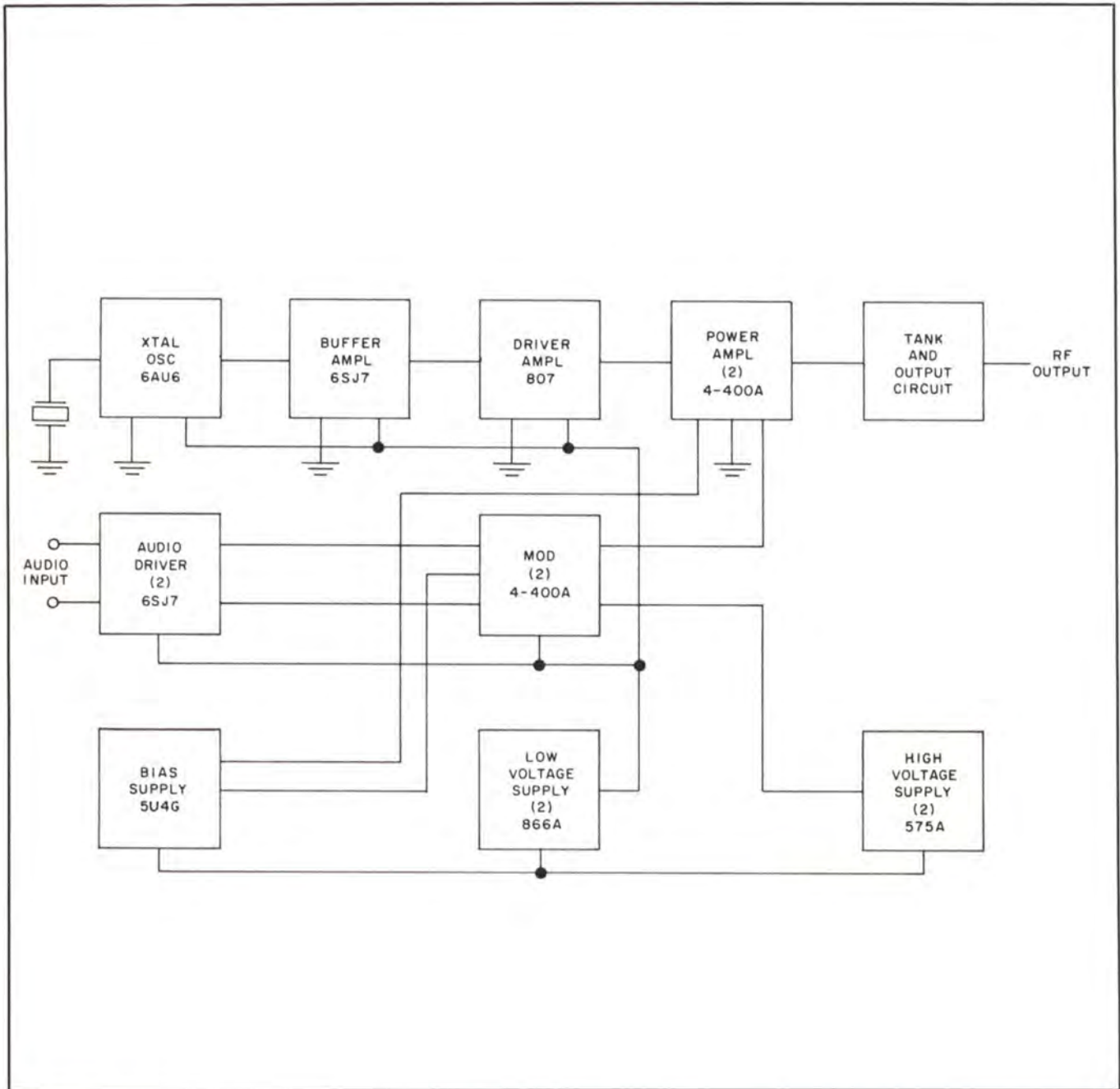

BLOCK DIAGRAM 20V-3

Power Demand (at 1,000 watts output):

Filaments	660 watts	85% pf
0% modulation	2,950 watts	80% pf
30% modulation	3,250 watts	83% pf
100% modulation	4,150 watts	83% pf

Tube Complement:

4	4-400A	2 — Final Amplifier
1	807	2 — Modulator
3	6SJ7	Driver Amplifier
1	6AU6	1 — Buffer Amplifier
2	575A	2 — Audio Amplifier
2	866A	Crystal Oscillator
1	5U4G	High Voltage Rectifier
		Low Voltage Rectifier
		Bias Rectifier

Ambient Temperature Range: +15°C to +45°C.

Size: 38" W, 76" H, 27" D (96.52 cm W, 103.04 cm H, 68.58 cm D).

Weight: Approx. 1,295 lbs (587.41 kg).

Part No. 522 2480

Includes one set of tubes, one crystal and one instruction book.

No Part Number

Complete set of spare tubes.

No Part Number

FCC set of spare tubes.

No Part Number

Factory short wave conversion, 1.6 mc-12 mc.

No Part Number

Spare crystal for 20V and 550A transmitters.



COLLINS 21E/M 5/10 KW AM TRANSMITTER

The 5,000-watt 21E and 10,000-watt 21M transmitters permit operation at any frequency from 540 kilocycles to 10 megacycles. A convenient power increase package converts the 5 kw 21E into a 10 kw 21M readily.

Straightforward styling of the transmitter cabinets is in keeping with the modern design of the transmitter circuitry. The cabinets are finished in high gloss, blue-gray baked enamel with polished chrome trim. Easy access to relays and contactors for inspection and adjustment is possible while the transmitter is on the air.

Pushbutton control of filament and plate power is provided. Automatic sequencing is supplied so that all filament bias and plate voltages are applied in correct sequence and with proper time delays. If desired, the pushbutton and indicating light circuits may be extended to a remote position.

A thermal time delay circuit is employed which gives the transmitter the ability to select the optimum time interval before it can be returned to the air after a power interruption. When a short power interruption occurs, the delay circuit allows only enough time for the filaments to reach operating temperature before the transmitter can be returned to the air. An arc-suppression circuit protects the final amplifier and RF driver tank circuits against arcs to ground due to lightning or other causes. Should an arc occur, this circuit removes plate power until the arc is extinguished and then returns the equipment to normal operation. Class AB₁ high level modulation is used to eliminate the audio driver transformer and its attendant problems. Adjustable overload relays are furnished for the RF driver, audio driver, power amplifier and modulator stages. Power supplies are heavy duty and conservative.

Plate voltage for the modulator and final amplifier is furnished by a common high voltage supply using six Type 575A rectifiers in a full-wave, 3-phase circuit. Bias for the modulator and final amplifier is provided by a common low voltage supply using two Type 866A rectifiers in a full-wave, 1-phase circuit. Driver unit has separate power supplies for high voltage, low voltage and bias.

The driver high voltage supply employs two Type 872A mercury vapor rectifiers in a single-phase, full-wave circuit. It supplies dc voltage for the plates of the audio drivers and the plates and screens of the RF driver tubes. The low voltage supply uses two Type 866A mercury vapor rectifiers in a single-phase, full-wave circuit to provide dc voltage for plates and screens of the low power stages and for screens of the audio driver tubes. The bias supply employs a 5U4G high vacuum rectifier in a single-phase, full-wave circuit. It supplies bias to the 807 amplifier, audio driver, and RF driver amplifier tubes, and dc

voltage for the arc-suppression circuit. The entire RF network is double shielded to reduce spurious radiation. RF circuits are completely independent of the cabinet proper.

A highly perfected oscillator design in conjunction with extremely stable, low temperature coefficient crystals has resulted in a frequency stability of better than ± 5 cps (typical performance is better than ± 2 cps) and has eliminated the troublesome crystal oven and its associated thermostats, relays and other controls.

Frequency Range: 540-1600 kc standard, frequencies to 10 mc available.

Power Output: 21E — 5,500/1,100 watts; 5,500/550 watts on order.

21M — 10,600/5,500 watts; 10,600/1,110 watts on order.

Power Increase Package: Converts 21E to a 21M.

Frequency Stability: Better than ± 5 cps. (Typical — Better than ± 2 cps.)

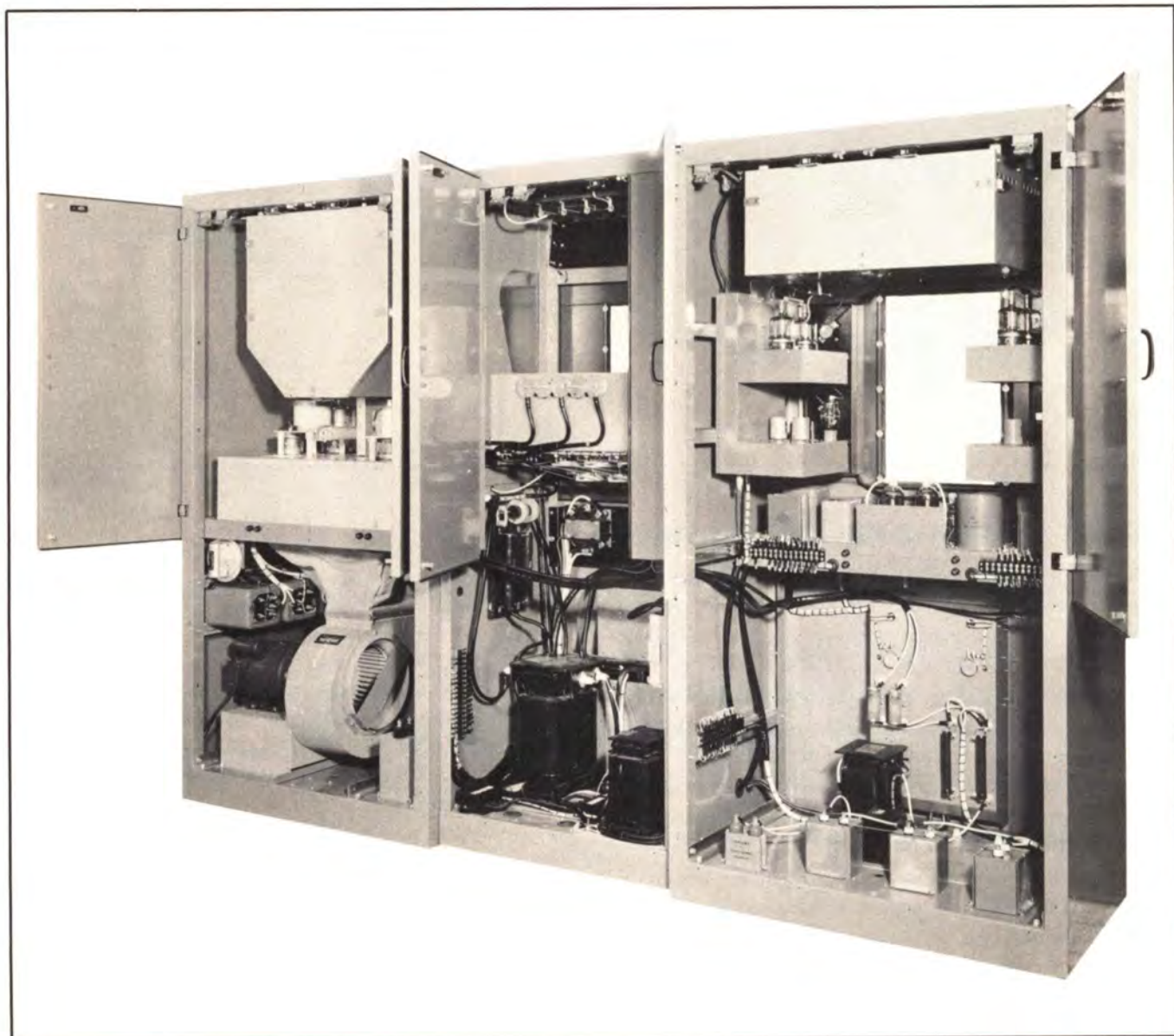

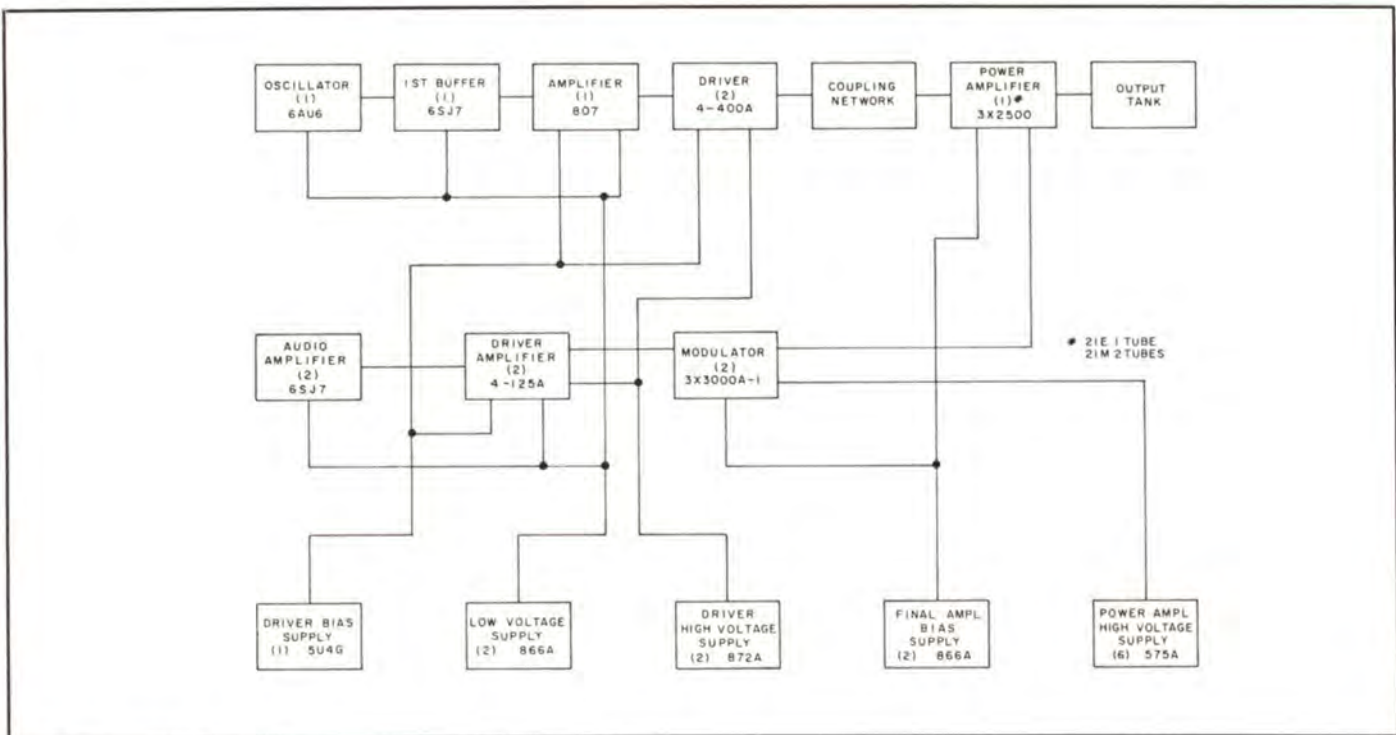

BLOCK DIAGRAM 21E/M

Audio Frequency Response: Within ± 2 db from 30-10,000 cps. (Typical — Within ± 1.5 db from 30-15,000 cps.)

Distortion: Less than 3% from 50-10,000 cps for 95% modulation, including all harmonics up to 16 kc. (Typical — Less than 3% from 30-15,000 cps.)

Residual Noise Level: 60 db or better below 100% modulation.

Carrier Shift: Less than 3%. (Typical value less than 2%.)

RF Output Impedance: 50 ohms unbalanced, 40-600 ohms unbalanced on order.

Audio Input Impedance: 150/600 ohms balanced.

Audio Input Level: +10 dbm, ± 2 db, 600 ohms input with built-in input pad. With the input pad removed, -5 dbm is sufficient for 100% modulation. 150 ohm connection of input transformer is possible when desired.

Power Source: 208/230 v, 50/60 cps, 3 phase; 50 cps on special order.

Power Demand:

	Power (kw)	Power Factor (%)
*5,000 watts		
Filaments and Blowers	2.64	—
Output — 0% Modulation	12.8	90.0
— 30% Modulation	13.8	90.0
— 100% Modulation	18.5	90.0
*10,000 watts		
Filaments and Blowers	3.28	—
Output — 0% Modulation	21.2	90.5
— 30% Modulation	23.6	90.1
— 100% Modulation	32.8	91.5

Tube Complement:

21E		21M
1 6AU6	Crystal Oscillator	1 6AU6
1 6SJ7	Buffer or Multiplier	1 6SJ7
1 807	Amplifier	1 807
2 4-125A	Driver	2 4-125A
1 3X2500A3	Final Amplifier	2 3X2500A3
2 6SJ7	Audio Amplifier	2 6SJ7
2 4-125A	Driver Amplifier	2 4-125A
2 3X3000A1	Modulator	2 3X3000A1
1 5U4G	Exciter Bias	1 5U4G
2 866A	Final Amplifier Bias	2 866A
2 866A	Low Voltage Plate	2 866A
2 872A	Intermediate Plate	2 872A
6 575A	High Voltage Plate	6 575A

Ambient Temperature Range: Up to 45°C.

Size: 105 1/4" W, 76" H, 28" D (267.34 cm W, 193.04 cm H, 71.12 cm D). (Plate transformer external.) Occupies 21 square feet of floor space.

Weight: 21E — Approx. 2,700 lbs. (1224.72 kg).

21M — Approx. 3,000 lbs. (1360.8 kg).

*21E capable of 5,500 watts output; 21M capable of 10,600 watts output.

Part No. 505 9578 (Type 21E)
Includes one set of tubes, one crystal and one instruction book.

No Part Number
Complete set of spare tubes for 21E.

No Part Number
FCC set of spare tubes for 21E.

No Part Number
5,000/500-watt 21E transmitter on special order. Price in addition to basic 5,000/1,000-watt unit.

Part No. 505 9580 (Type 21M)
Includes one set of tubes, one crystal and one instruction book.

No Part Number
Complete set of spare tubes for 21M.

No Part Number
FCC set of spare tubes for 21M.

No Part Number
10,000/1,000-watt 21M transmitter on special order. Price in addition to basic 10,000/5,000-watt unit.

No Part Number
Factory short wave conversion, 1.6 mc-10 mc.

No Part Number
Spare crystal for 21E/M.



CHA-250 CONSOLE

COLLINS CHA-250 kw HF TRANSMITTER

Collins type CHA-250 is a high-frequency broadcast transmitter having a minimum carrier output of 250 kilowatts. The CHA-250 represents advanced state-of-the-art techniques which have been adapted to serve the needs of the international broadcaster. The trouble-free tuning and control techniques used in thousands of transmitters built by Collins Radio Company in the past few years were applied during the design of the CHA-250, resulting in a transmitter of extraordinary operating simplicity.

The CHA-250 transmitter has two features never before offered in a transmitter of this power level:

- (1) The ability to tune to any frequency in the 3.95- to 26.5-mc band in 20 seconds or less
- (2) An r-f power amplifier low-loss output tank circuit having no rolling, sliding, or switching contacts.

In broadcasting, on-the-air time is of utmost importance. The Collins CHA-250 transmitter can perform a complete tuning sequence in 20 seconds or less. This feature not only provides a considerable savings in off-the-air time, but it permits a frequency change to be per-

formed in the time normally allocated for a station break. For example, assume the use of a conventional transmitter operating on an r-f circuit requiring an average of four frequency changes daily. Further, assume that the time required to change frequencies on the conventional transmitter to be 5 minutes and that the station programs in 15-minute increments. A comparison of the conventional transmitter and the CHA-250 transmitter tuning times reveals the great advantage the CHA-250 has over any conventional transmitter.

One CHA-250 transmitter, with the ability to change frequency during station break, can provide 1 hour more on-the-air time daily than the conventional transmitter.

A further advantage offered by the CHA-250 is a pre-set feature to permit programming the automatic tuning circuits of the transmitter in advance of the next frequency change while the transmitter is in operation. This is accomplished by pre-setting the transmitter controls, which provide direct digital readout of the operating frequency, and the exciter crystal selector control for the correct crystal frequency. At the time for frequency

change, depressing the TUNE START pushbutton starts the tuning sequence, which is accomplished in 20 seconds or less. Automatic dissipation protection circuitry protects the r-f driver and power amplifier tubes against over-dissipation during any condition of tune-up. It is evident from the above description that a frequency change can easily be accomplished on the CHA-250 transmitter by one operator with a minimum of training.

The pi-line low-loss r-f power amplifier tank circuit and harmonic filter represents a major engineering breakthrough, which is exclusive to the CHA-250 transmitter. It not only obviates the requirement for any rolling, sliding, or switching contacts in this high-power circuit, but it provides a reduction in power loss of more than 50 percent over the equivalent circuit offered by any other transmitter of this power level.

ELECTRICAL SPECIFICATIONS.

Emission: High-level amplitude modulation (A3), Frequency Shift Keying (F1).

Frequency Range: 3.95 to 26.5 mc, continuous coverage.

Frequency Control: By oven controlled crystal oscillator (two each furnished), or by either of two customer-furnished external signal sources.

Frequency Stability with Type CR-27/U Crystals: From +5° to +50°C and primary voltage variation ±10%, less than 5 parts per million frequency change per 24-hour period. Greater stabilities obtainable with higher quality crystals.

Tuning Time: Frequency change accomplished in 20 seconds, maximum.

Tuning Mode: Automatic.

Power Output: At least 250-kw unmodulated carrier power.

Carrier Shift: Less than 5%, exclusive of that caused by primary power.

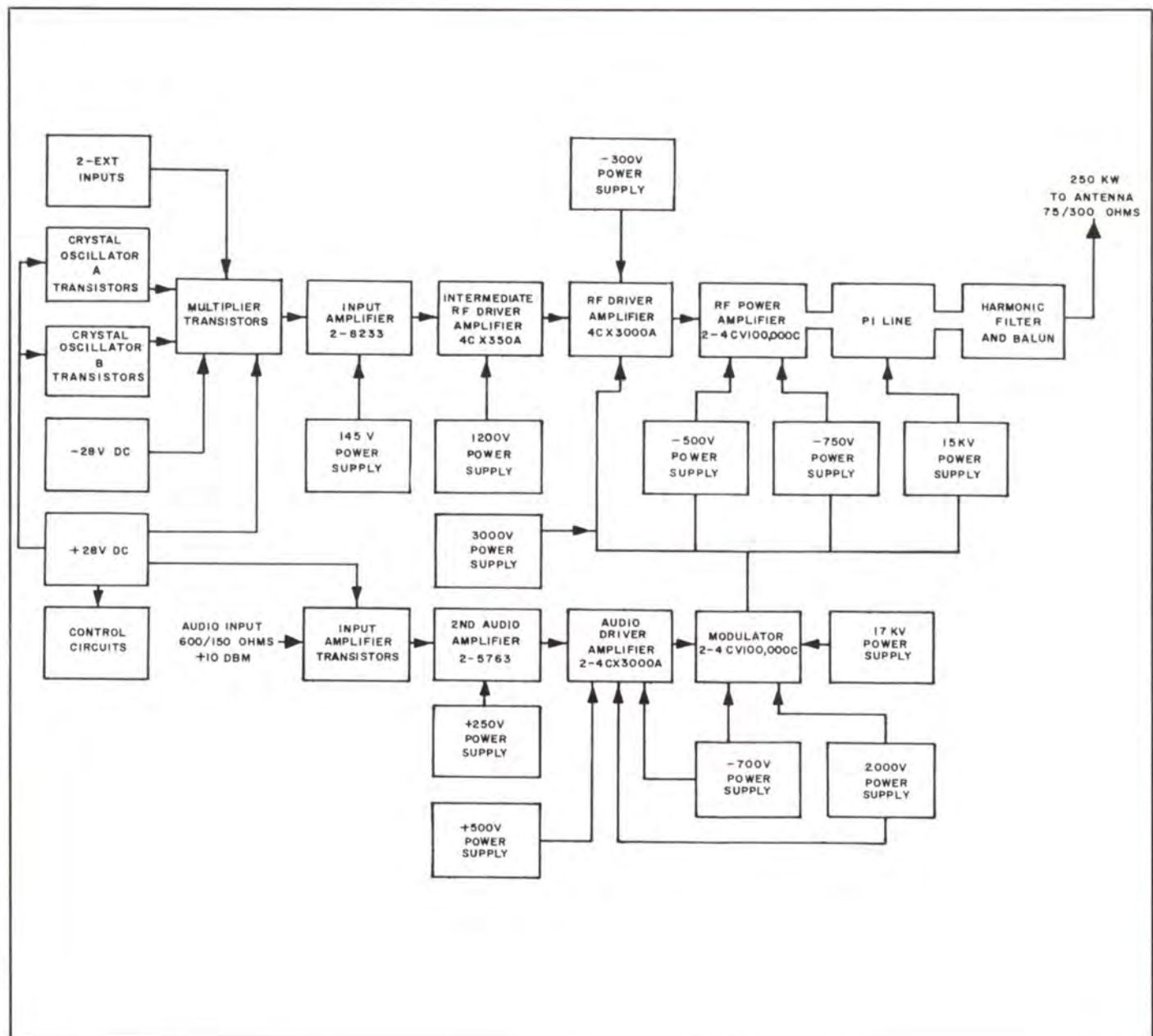

SIMPLIFIED BLOCK DIAGRAM

Output Impedance: 300 ohms, balanced; 75 ohms, unbalanced.

VSWR: 1.5:1, maximum.

Type of Modulation: High-level AM, FSK.

Modulation Capability: Capable of 100% sine wave or clipped sine wave. Less than 5% tilt or overshoot for trapezoidal waveform from 100 to 3000 cps.

Modulation Duty Factor: Continuous at 100% sine wave; 5 minutes at 100%, clipped sine wave.

Audio Input for 100% Modulation: +10 dbm, ± 2 db.

Audio Input Impedance: 600/150 ohms, balanced or unbalanced.

Audio Response: Within 1 db from that at 1000 cps between 100 and 7500 cps and within 2 db between 50 to 10,000 cps, at all modulation levels up to 95%.

Audio Distortion: Not more than 4% distortion when modulated 100% over the frequency range of 100 to 5000 cps; and not more than 5% from 50 to 100 cps and from 5000 to 7500 cps.

Noise Level: Carrier hum and extraneous noise is at least 50 db (unweighted) below 100% modulation.

Harmonic and Spurious: All harmonics and harmonically related spurious emissions are at least 80 db below carrier level. Incidental phase modulation products that occur close to the carrier and are a result of (1) random crystal variations, (2) power supply ripple, (3) power supply regulation during modulation, (4) mechanical vibration of the crystal, and which appear in the output of the transmitter are at least 43 db below 1 radian.

Power Input:

At Rated Carrier Output: 455 kw at 85% pf

At 100% Sine Wave: 682 kw at 85% pf

Power Source: 4160 volts, $\pm 3\%$; 60 cps, $\pm 5\%$, 3-phase, 3-wire (50 cps optional).

Altitude: 0 to 6000 feet.

Temperature: +5° to +50°C at sea level; +5° to +38° at 6000 feet.

Humidity: 0 to 95% relative humidity.

Storage: -35° to +60°C.

Power Source: 4160 volts $\pm 3\%$ (steady state) $\pm 33\%$ (instantaneous); 60 cps $\pm 5\%$ (steady state); $\pm 3\%$ (instantaneous) (50 cps optional)

No Part Number

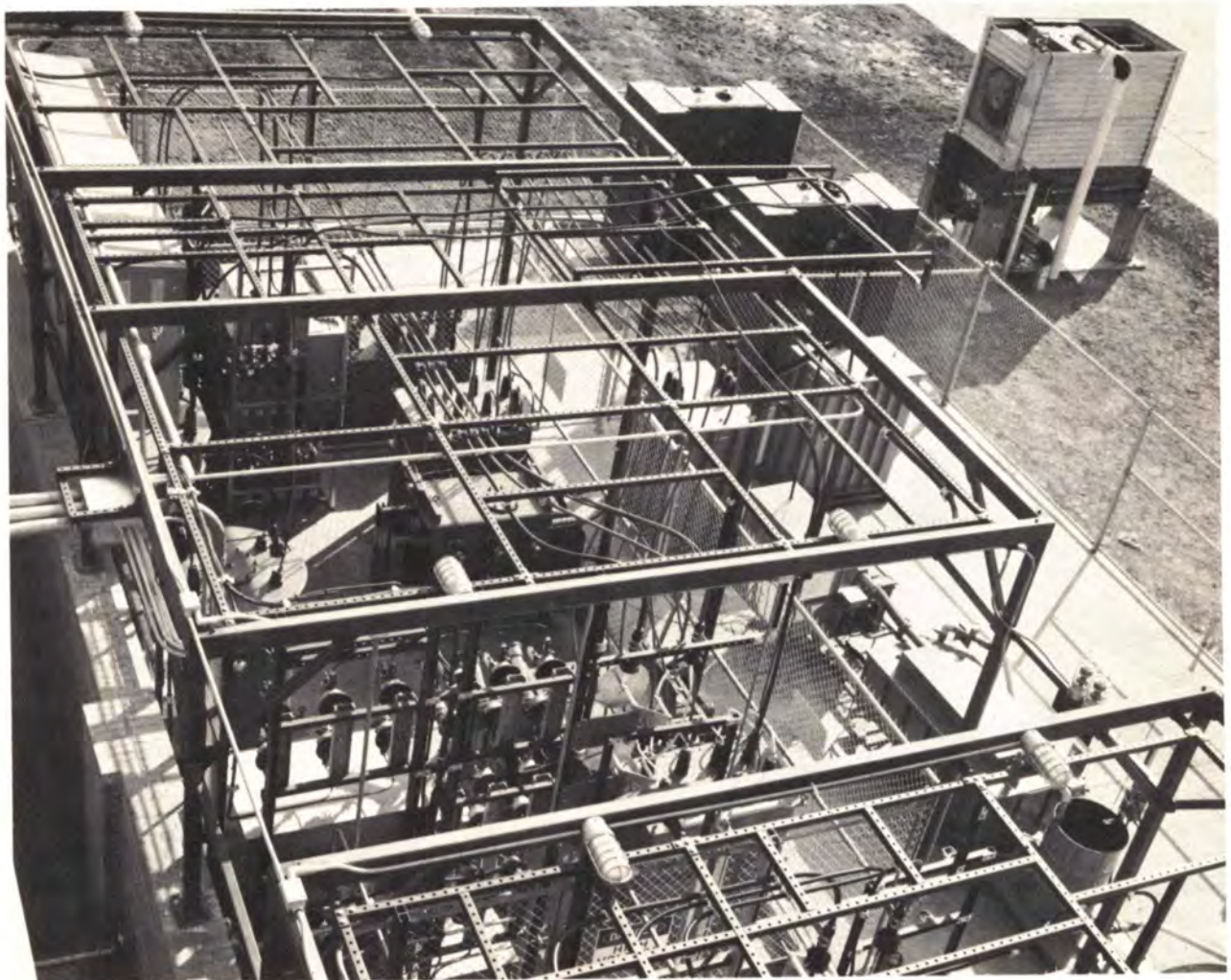

OUTSIDE PORTION CHA-250

COLLINS AM TRANSMITTER CONVERSION KITS

The conversion kits listed below for the various Collins AM transmitters include all transformers, meters and necessary capacitors for the same frequency. Crystals are not included. One set of tubes is included for the final RF and audio stages only and any necessary rectifiers. Components for frequency change are additional.

No Part Number
300J-2 to 550A.

No Part Number
550A to 20V-2.

No Part Number
330J-2 to 20V-2.

No Part Number
21E to 21M.

COLLINS 172G DUMMY ANTENNA

This air-cooled unit provides a load to dissipate transmitter output for off-the-air testing. Consisting of 8 ferrule type, non-inductive resistors, with insulated end brackets and clips, it may be mounted on the transmitter or adjacent wall. The 172G-1 has an impedance of 52 ohms; the 172G-2, 73 ohms.

Power Rating: 1 kw.

Size: Approx. 6" W, 9" H, 12½" D (15.24 cm W, 22.86 cm H, 31.75 cm D).

Weight: 5 lbs. (2.27 kg).

Part No. 522 1410 014 (Type 172G-1)
Part No. 522 1411 014 (Type 172G-2)

STATES WG-52 DUMMY ANTENNA

An air-cooled dummy load to dissipate output of the Collins 21E AM Transmitter. The WG-52 has an impedance of 52 ohms and a peak of 7.5 kw.

Part No. 097 8138 00

COLLINS TOWER LIGHTING FILTER CHOKES



These solenoid wound 2- and 3-wire chokes provide high impedance throughout the broadcast band for isolation of the ac power lines from the antenna. Coils are wound of #10 wire and are rated at 2,000 watts, 120

v ac, single phase. Provided with mounting brackets and standoff insulators for mounting in 42E-7/8 antenna coupling units.

Part No. 543 3927
Unhoused, 2-wire, 2,000 watts.
Part No. 543 3926
Unhoused, 3-wire, 2,000 watts.

COLLINS 42E ANTENNA COUPLING UNITS

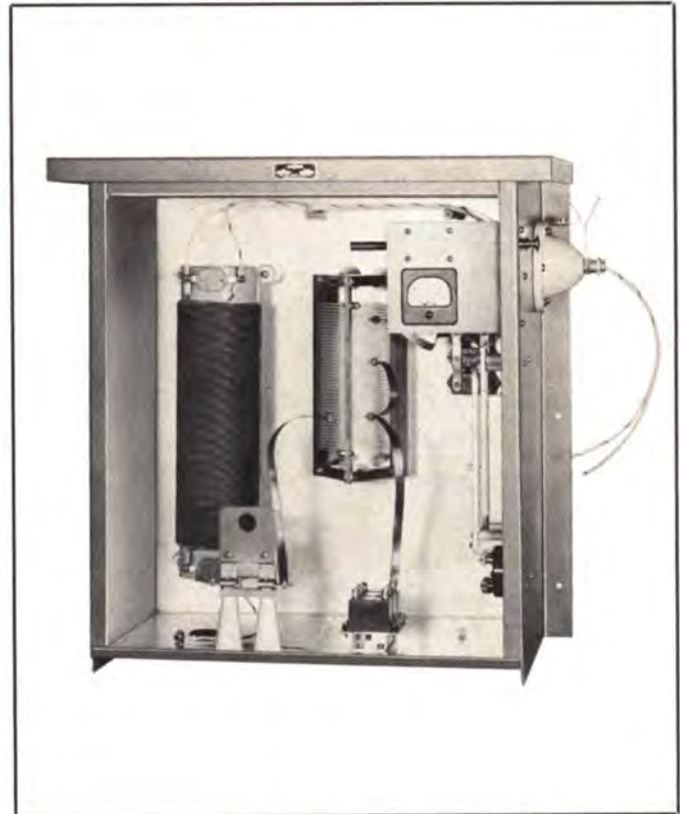

These specially constructed units match a series-fed vertical radiator to an unbalanced transmission line. Intended for continuous, unattended duty in conjunction with transmitters having emission type A0, A1, A2 or A3, the 42E-7 operates with transmitters of carrier power output of 250-1,000 watts. The 42E-8A operates with transmitters of 5,000 watts and the 42E-8B operates with transmitters of 10,000 watts.

The electrical circuit of the 42E Antenna Coupling Units is a low-pass "T" network with good harmonic attenuating properties. A three-wire or two-wire tower lighting filter choke and remote antenna current sampling transformer may be mounted in the cabinet, and an antenna current meter and line current meter jack are provided.

A horn gap furnishes lightning protection. The antenna connection is made by an insulated feed-through bushing on the side of the cabinet and the bushing has a hollow stud for the lighting circuit. The transmission line comes through the base of the cabinet. Gray weatherproof aluminum housing. Remote antenna current metering kit and antenna current transformer

for remote reading of antenna current up to 25 amps available for all Collins AM Transmitters.

Size: 42E-7 — 29" W, 28" H, 18" D (73.66 cm W, 71.12 cm H, 45.72 cm D).

Weight: 64 lbs. (29.03 kg).

Size: 42E-8A/B — 36" W, 28" H, 22" D (91.44 cm W, 71.12 cm H, 55.88 cm D).

Weight: 124 lbs. (56.25 kg).

Part No. 522 1028 (Type 42E-7)
Part No. 522 1029 (Type 42E-8A)
Part No. 522 1029 (Type 42E-8B)

COLLINS REMOTE ANTENNA METERING KIT

The Collins remote antenna current metering kit is designed for the Collins series of AM transmitters. The kit for the 20V-3 includes RF transformer, thermocouple, remote meter and meter mounting bracket. Specify type of tuner, base current of tower, base resistance or complete description of antenna system.

The kit for the 21E and 21M transmitters includes RF transformer and thermocouple. (Remote meter is included in transmitter.) Specify type of tuner, base current of tower, base resistance or complete description of antenna system.

No Part Number
For 20V-3 Transmitters.

No Part Number
For 20V-3 Transmitters. Same as above but with expanded scale and matching thermocouple.

No Part Number
For 21E/M Transmitters.

COLLINS ANTENNA CURRENT TRANSFORMER



Used with remote thermocouple and meter for remote monitoring of antenna current. For currents up to 25 amps. Thermocouple not included.

Part No. 543 3917

PHASING

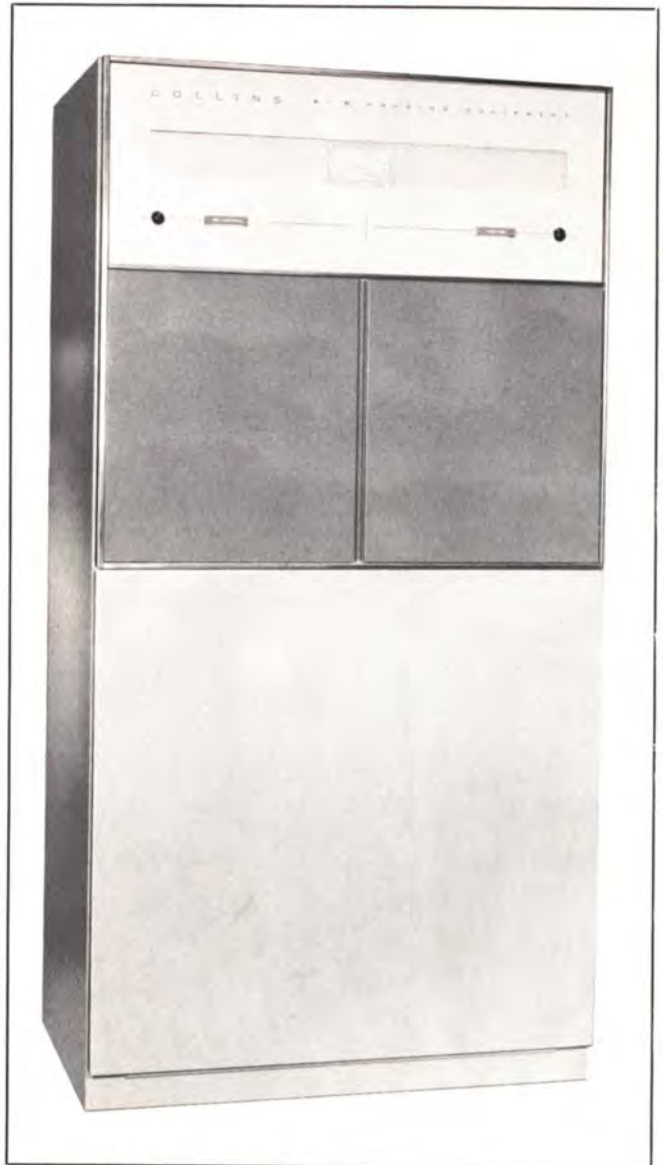

COLLINS 81M PHASOR

Collins Radio Company maintains a research and development staff which devotes its full efforts to custom design and manufacture of phasing and tuning equipment that will meet critical operating parameters with a minimum of maintenance and adjustment. By instituting its own design and construction, Collins can offer fastest possible delivery, maintain its famous standard of quality and sell at the lowest possible cost.

Engineered into each installation are easily-adjusted networks, highest stability, adequate voltage and current safety factors and maximum economy. A customer's requirements, as specified by his consulting engineer, are strictly adhered to and designs are submitted for approval before construction is started.

After the consulting engineer has made channel studies for an available frequency, he will design an array to fit the location, frequency and other requirements. He will

determine the pattern shape and size in both the vertical and horizontal planes, the maximum expected operating values of fields in both the nulls (minimum signal areas) and the lobes (maximum signal areas), the proper size, shape, height, spacing, and orientation of the antenna towers, and the phase relationships and amplitude ratios of the radiation fields of the individual antennas. This information is then submitted to the FCC with the application for a construction permit.

A Collins 81M directional antenna phasing and branching system consists of: a branching circuit in which the

power is divided in precisely the amounts of power necessary to give the proper ratio of fields from the individual antennas; an impedance matching circuit to match the power divider input impedance to the common point impedance at which the power input is measured; phase shifting networks in series with each of the transmission lines going to the individual antenna towers; the transmission lines themselves; and the impedance matching network between each of the transmission lines and its associated antenna tower.

The power divider in Collins 81M equipment is usually

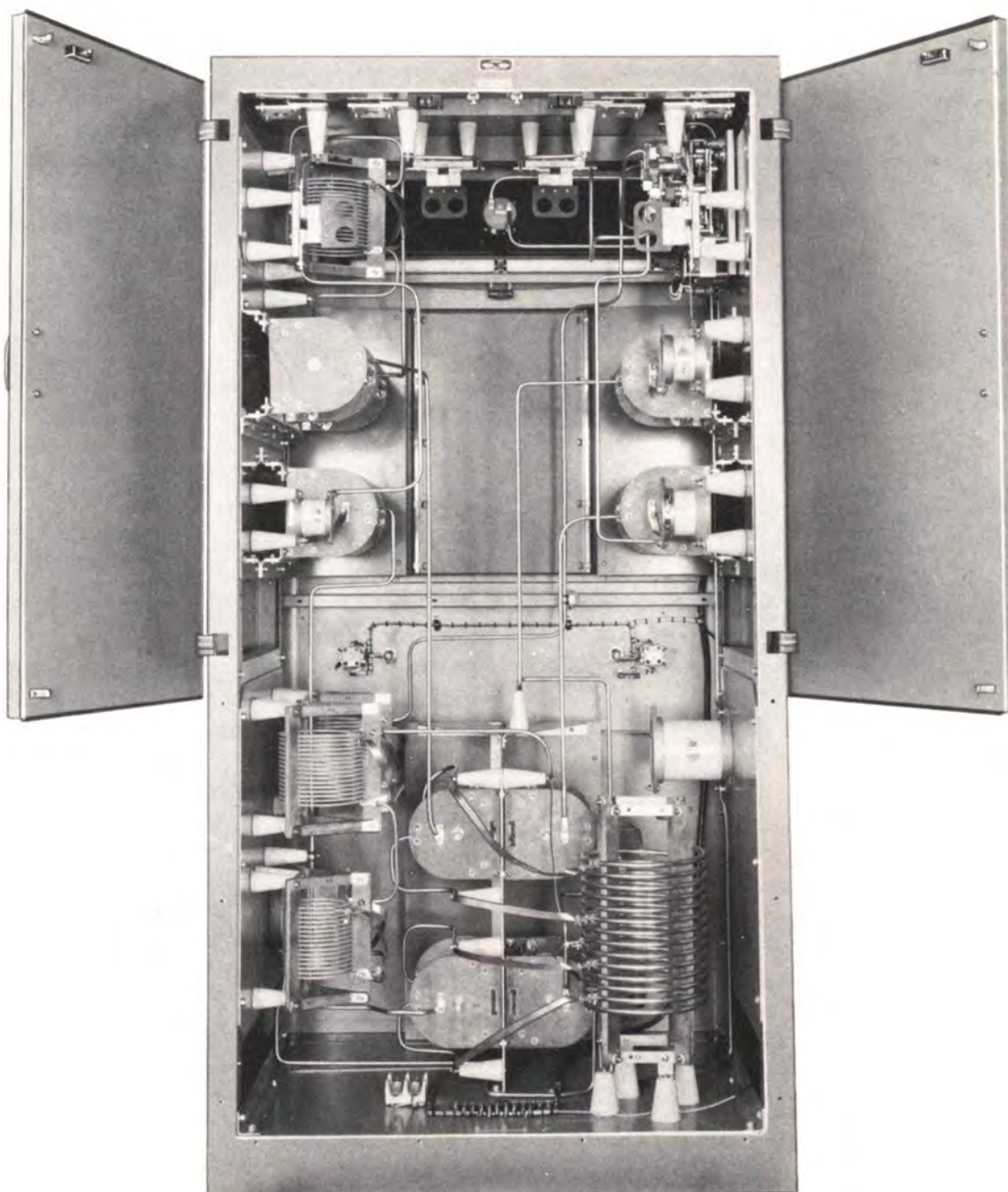

a resonant tank circuit consisting of a large fixed coil tapped with smaller variable coils for power adjustment. An alternate design uses a group of variable coils, each one feeding a tower; this group then becomes the tank coil of the circuit.

For 1 kw or lower, the capacitive arm of the tank circuit is a capacitor and variable coil connected in series. The variable coil provides tuning adjustment by varying the over-all negative reactance in this branch of the tank. In higher powers, the tank capacitance is usually a variable vacuum capacitor in parallel with one or more fixed capacitors.

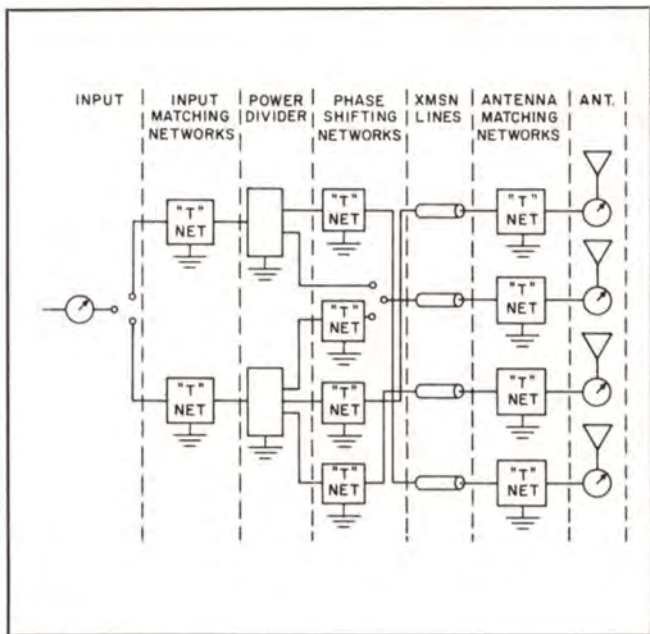

TYPICAL PHASING SYSTEM

Phase shifting networks are "T" designed, with variable coils mechanically connected in tandem for the series arms and a coil and capacitor in series for a shunt arm. Wherever possible, 90° networks — capable of being adjusted $\pm 30^\circ$ from the design value — are supplied.

Wherever a phase shift network is not required, a series variable coil and capacitor are used to supply variation of $\pm 20^\circ$ around a 0° setting. They are used for trimming phase shift of current in the towers in which they are used.

"T" networks are also used for impedance matching at the tower base. The network has sufficient latitude of adjustment to match the transmission line impedance to any expected base operating impedance and still permit adjustment of phase shift.

Switching of circuits for day and night operation or directional and non-directional operation is accomplished by impulse-type, toggle-operated RF relays, energized by pushbutton switches on the front panel. The pushbutton automatically removes the plate voltage of the transmitter before pattern switching and restores it when switching is completed. Interlocks on the cabinet doors also remove the plate voltage when doors are opened.

Amplitude and phase controls have counters to assure accurate resetability. In complex arrays requiring additional controls, the controls and counters are behind the tilt-out panel in the lower half of the cabinet.

Power dividing circuits and phase shift networks utilize heavy edge-wound copper ribbon inductors and ceramic cased mica capacitors. Vacuum capacitors are used where made necessary by high circulating currents.

Plated 5/16" copper tubing is used for all RF busses and insulation is steatite or Mycalex.

Input and output connections are provided at the top of the phasing cabinet unless otherwise specified. Special terminations are provided for solid dielectric cables in both the phasing cabinet and antenna coupling units.

An input common point RF ammeter is supplied along with line current meter jacks. Antenna current meters have make-before-break switches, which can be operated without opening the cabinet door on the weatherproof coupling units.

Extensive descriptions of typical systems are available upon request of CDS-377.

Power: 1, 5 and 10 kw in 2-, 3-, 4-, 5-, and 6-tower arrays.

Patterns: Directional day and night, same pattern; directional nighttime only; or different pattern day and night.

Size: 38" W, 76" H, 27" D (96.52 cm W, 193.04 cm H, 68.58 cm D). (Complex Collins 81M phasing systems may require two cabinets totaling 76" W.)

No Part Number

COLLINS 564A-1 PHASE SAMPLING LOOP



Designed to sample the relative phase relationship of radio frequency energy from 550-1600 kc antenna towers

in directional antenna arrays, the Collins 564A-1 is made of two loops of #10 copper wire which may be connected either in series or in parallel. The wires are contained within a loop of 7/8" painted, copper tubing which serves as an electrostatic shield.

A universal coupling permits the loop to be connected to any type of pressurized or unpressurized air or solid dielectric transmission line. The loop offers a good match to lines of 50-75 ohms impedance. A universal mounting bracket allows the loops to be mounted on any part of the antenna structure.

Size: Approx. 30" W, 7' 6" H (76.2 cm W, 228.6 cm H).
Weight: 50 lbs. (22.68 kg).

Part No. 522 1518 004

COLLINS 564A-2 PHASE SAMPLING LOOP

An unshielded loop of galvanized iron pipe.

Size: Approx. 42" W, 7' 2" H (106.68 cm W, 218.44 cm H).

Weight: 35 lbs. (15.88 kg).

Part No. 522 1519 004

COLLINS 144A-1 ISOLATION COIL



Coil provides isolation for the sampling line in directional arrays, presenting a high impedance for the line across the base insulator. Unit consists of a phenolic coil form which will accommodate 37 turns of RG8/U or similar solid dielectric sampling line. May be mounted on wall of tuning shack or in housing (pictured).

Inductance: Approx. 180 microhenrys.

Size: 10" diameter, 18" L (25.4 cm diameter, 45.72 cm L).

Weight: 6 lbs. (2.72 kg).

Part No. 522 1520 (Type 144A-1)

JOHNSON RF CONTACTORS

The 145-100 and 145-200 contactors are especially designed for high voltage radio frequency switching and dc voltage switching in high voltage rectifier circuits. They require no "holding" power and will operate with a momentary application of voltage.

Standard contactors are supplied with four auxiliary switches: two "normally closed" for control of solenoid voltage and two "normally open" for operation of signal lamps or other related functions. Solenoids are wired for 220 v, 50-60 cps or 110 v, 50-60 cps on special order.

Part No. 410 0209 00 (Type 145-101-13)
Part No. 410 0210 00 (Type 145-102-13)
Part No. 410 0211 00 (Type 145-201-13)
Part No. 410 0212 00 (Type 145-202-13)



Type No.	Maximum Current	Contacts	Maximum Contact Rating (at 2 mc)	Size
145-101-13	4 amps	SPDT	17 kv, 25 amps	(20.0 cm W, 13.97 cm H, 16.51 cm D)
145-102-13	4 amps	DPDT	17 kv, 25 amps	(20.0 cm W, 13.97 cm H, 16.51 cm D)
145-201-13	8 amps	SPDT	22 kv, 25 amps	(26.67 cm W, 15.88 cm H, 20.96 cm D)
145-202-13	8 amps	DPDT	22 kv, 25 amps	(26.67 cm W, 15.88 cm H, 20.96 cm D)

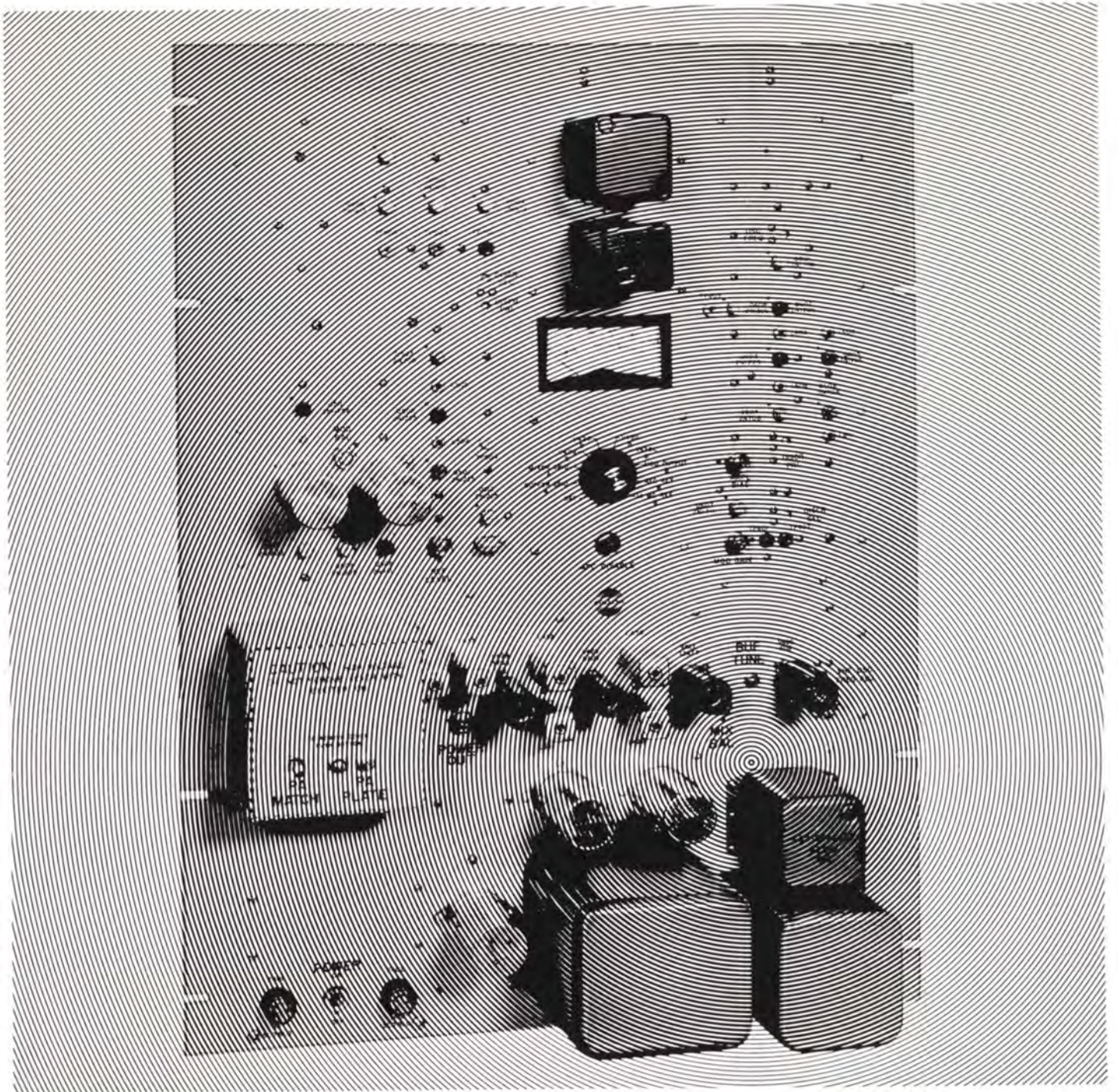

FM TRANSMITTERS

WHAT'S THE MYSTERY ABOUT STEREO?

The mystery of stereophonic FM broadcasting is wiped away with the new, straightforward Collins approach. Not only does Collins equipment faithfully reproduce "live" sound in both direction and dimension, it also assures the stereo broadcaster a stable system of transmission. The Collins method of composite signal generation does away with the costly and unstable equipment needed in conventional double-injection system of stereo broadcasting.

Amplitude differences result from the directional characteristics of the human ear and the baffle effect produced by the head. The time differences result from the difference in path length to each ear from a sound source which is off to one side.

To provide a realistic stereo effect, the time delay and amplitude differences between the signal received by the left and right ears must be maintained from the original sound source to the ear of the listener. The problem becomes one of maintaining amplitude and phase differences to provide adequate channel separation.

Left and right channels must have proper *balance* to give the listener faithful reproduction of a live presentation. If the source of sound moves to the left on the program stage, the left channel's volume must increase and the right channel's volume decrease proportionately to convey accurately the change of direction of the sound source.

Adequate channel separation — at least 30 db — must be maintained. Lack of adequate *separation* would permit "bleeding" of one channel's sound into the other, thus moving the sound source to an apparent center from the listener's point of view.

Finally, *compatibility* is required. The transmitted stereo signal must be capable of being received not only by the stereo FM receiver, but by existing monaural receivers as well.

To comply with FCC requirements, a signal which can be received by monaural receivers must be transmitted. This signal is the combination of the left and right channels, or L+R. To achieve stereo broadcasting, a subcarrier FM signal provides the vehicle for the third dimensional sound. This is the L-R channel.

The Collins 786M-1 FM Stereo Multiplex Generator achieves this L-R signal by a mathematical system of

time division. More of this later. Basically, then, the stereo FM receiver gets two signals, an L+R and an L-R. To feed the left channel and the receiver's left speaker, the receiver adds the L+R and L-R signals and derives 2L. The same process by subtraction yields 2R in the right speaker. Since the figure 2 represents a volume control setting, the receiver in effect recovers the L and R sound originally produced at the left and right microphones on the program stage.

Returning to the time division principle, it is this factor which makes the Collins Stereo Generator a standout unit in operation and maintenance. In the conventional stereo generation system, two channels are required to feed L+R and L-R to the exciter. This technique, known as matrixing, requires gain and phase shift between the two channels be maintained within close tolerances to maintain adequate channel separation throughout the system.

Collins' new approach eliminates the need for continual surveillance of time delay shifting between the two channels by eliminating the double-injection system entirely.

Instead, the direct FM wide band exciter is fed a *single, composite signal on one wire*. Any shift in gain or phase will affect both channels equally, thus maintaining the 35 db channel separation. Not only does this assure the broadcaster an inherently stable method of stereo transmission, but greatly simplifies both operation and maintenance.

The rather expensive matrix networks needed in the dual channel system are eliminated as are the time delay switches needed to match the channels when a shift in gain or phase occurs.

The Collins time division system of stereo signal generation is nothing more than a sampling at a 38 kc rate of left and right audio inputs. The output from the switch is equivalent to L+R plus the L-R double sideband components centered on the switching frequency (38 kc) and its odd harmonics.

The composite wide band spectrum accepted by the exciter would include the L+R signal, a 10% 19 kc pilot carrier inserted for phasing reference, the L-R DSB components centered on the 38 kc subcarrier, and the 67 kc SCA channel when an auxiliary SCA generator is installed.

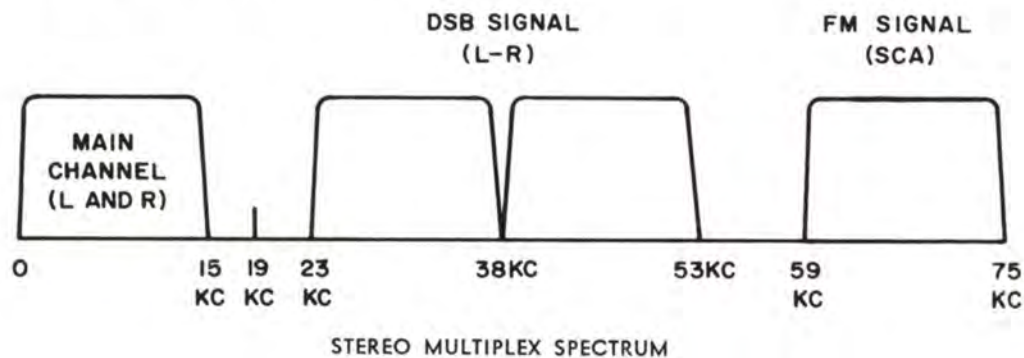

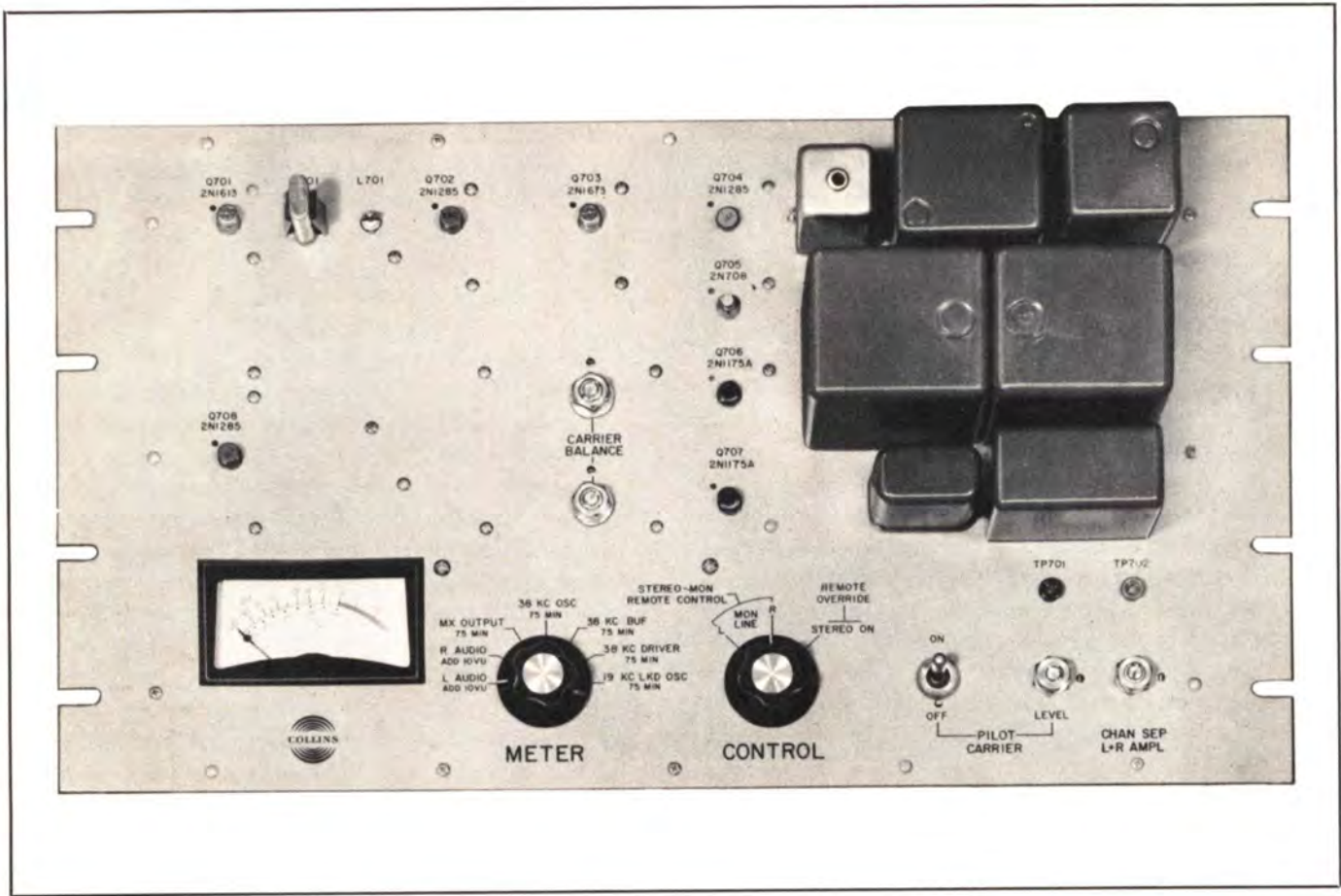

786-1 FM STEREO MULTIPLEX GENERATOR

A stable and reliable method of stereophonic FM broadcasting is now available through the new time division system where both stereo channels are integrated into a composite signal which is fed to a wide band exciter (Collins A830-2) on a single line.

The Collins 786M-1 FM Stereo Multiplex Generator does away with the inherent instability of the conventional dual channel method of stereo injection.

Instead, the Collins 786M-1 feeds monaural audio and the subchannel, required for stereo operation, to the exciter on a single, composite signal. The time division system eliminates the costly and unstable dual channels which require matrix networks. L + R and L - R outputs of the matrix networks must be compensated to make up time differences in the two channels. Also, accurate amplitude balance between the two channels must be maintained. In the Collins system, this problem is eliminated by using a wide band direct FM exciter. With a system of this type, any gain changes or time delays will affect the main and sub-channels equally.

The Collins time division system is nothing more than a sampling at a 38 kc rate of the left and right audio inputs. After transmission, a corresponding component in the FM receiver demodulates the composite signal in

synchronism with the sampling, converting it to left and right audio through the respective speakers.

The composite stereo signal (L + R and L - R) is achieved by filtering out unwanted harmonics created in the function of the four-diode time division switching circuit. The resulting spectrum shows only the main channel (L + R) which is the monaural signal; a 10% 19 kc pilot carrier; the subchannel (L - R) which is the stereo signal on a 38 kc carrier. An SCA channel may be placed on a 67 kc carrier by addition of an auxiliary SCA generator.

Features of the 786M-1 are:

SIMPLE CIRCUITS — The single line, time division system eliminates matrixing components, greatly simplifying circuitry.

STABLE — All components are temperature-compensated to provide long-term stability. The unit is completely transistorized.

SELF-METERED — An audio VU meter monitors both audio inputs and interior circuit points for rapid maintenance.

EASILY INSTALLED — The Collins 786M-1 may be installed in the 830B-1A, 830D-1A or 830E-1A FM, 830F-1A, 830F-2A, 830H-1A, 830N-1A.

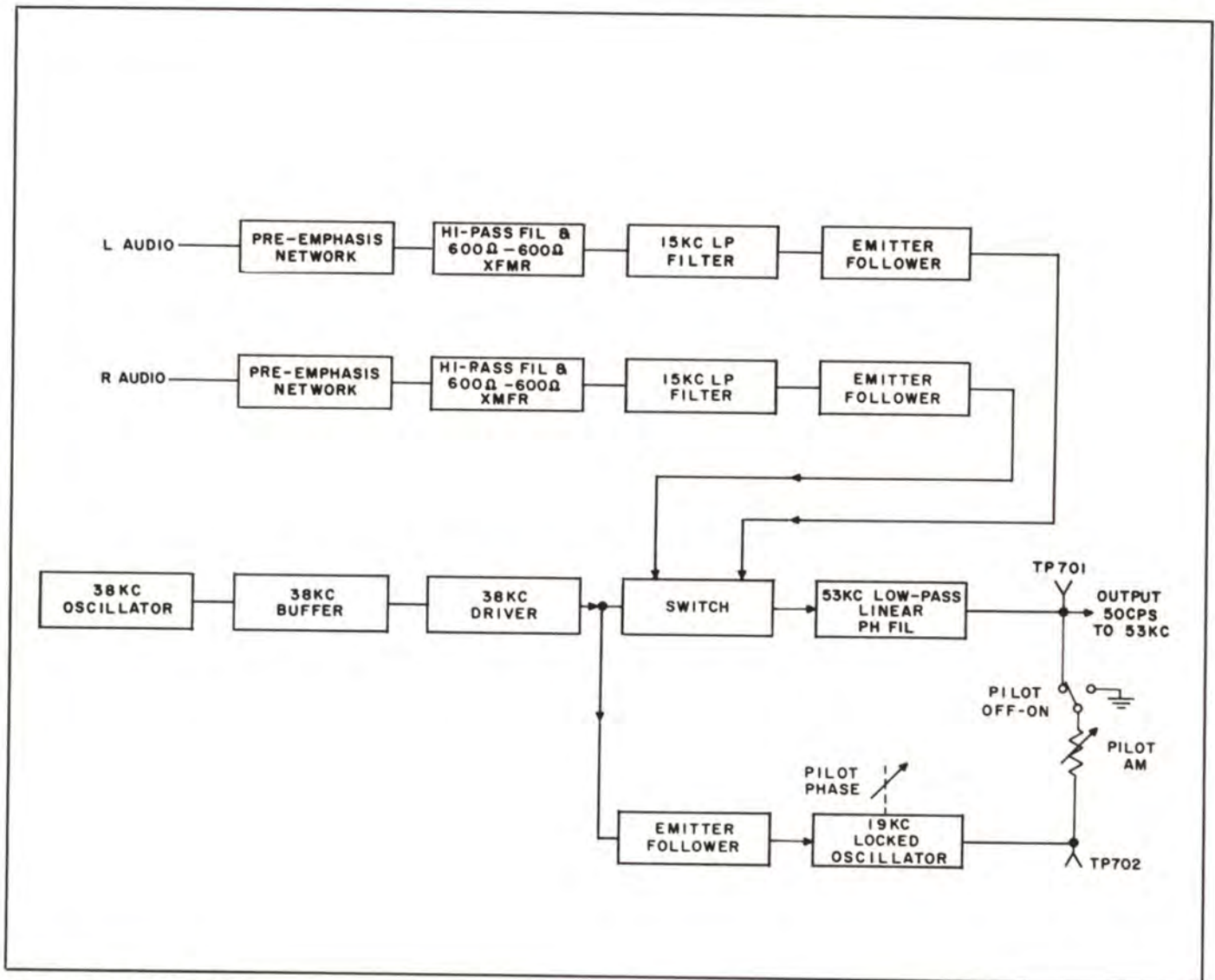

BLOCK DIAGRAM 786M-1

Pre-emphasis networks are plug-in type; can be replaced with 20 db flat pad for testing. *Hi-pass filter and 600 ohm-600 ohm transformers* prevent interference with exciter AFC circuits by any 5 cps components in input. Transformers convert from balanced to unbalanced inputs. *15 kc low pass filters* limit bandwidth to 15 kc to prevent cross-talk between main and sub-channels. Filters provide over 60 db attenuation for frequencies above 19 kc. *Emitter followers* provide isolation between left and right audio inputs and stereo switch. *38 kc oscillator, buffer and driver* provide 38 kc drive signal to the stereo switch. When 38 kc carrier goes positive, upper pair of diodes in *switch* conduct and connect left channel to output; when carrier goes negative, lower pair of diodes connect right channel to output. L+R correction is obtained by feeding left and right signals around switch through two resistors. *The 53 kc low pass linear phase filter* removes high frequency switching components which would fall outside the assigned bandwidth. The

filter meets the requirement of constant time delay for all frequencies up to 53 kc. Main channel audio and sub-channel DSB crossings thus occur simultaneously. The filter also has flat frequency response to 53 kc. These two factors are held to tolerances which provide over 35 db channel separation for 50-15,000 cps audio input frequencies rising to 38 db at 5 kc. *The emitter follower and 19 kc locked oscillator* provide a 19 kc pilot carrier in phase with the 38 kc subcarrier at the output of the linear phase filter.

Distortion (either channel): Less than 1%, 50-15,000 cps.
Channel Separation: 35 db or greater, rising to 38 db at approx. 5 kc.

Pilot Carrier Stability: ± 2 cps at 19,000 cps.

Output Impedance: 600 ohms unbalanced.

Size: 19" W, 8 $\frac{3}{4}$ " H, 3 $\frac{1}{8}$ " D.

Weight: 14 lbs.

Part No. 522 2914 00

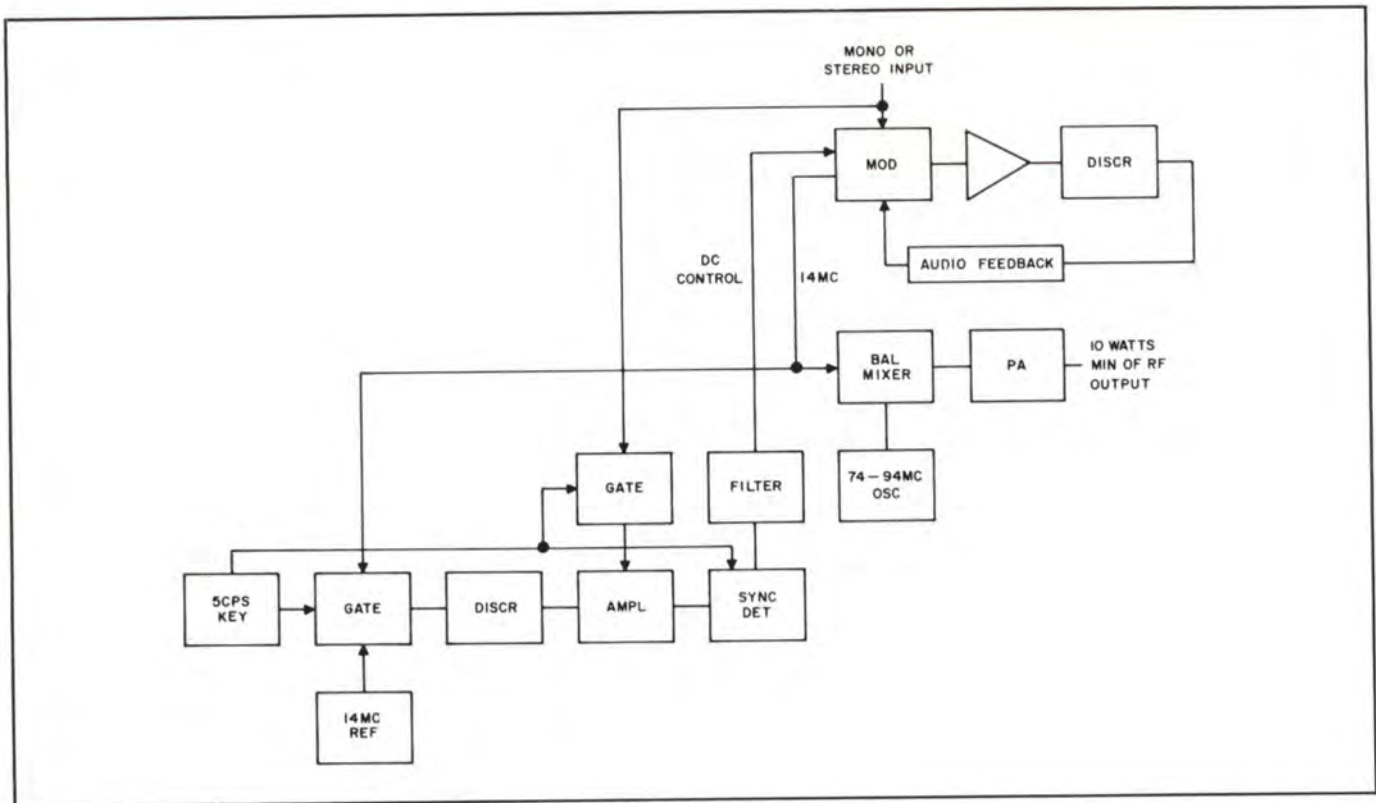

BLOCK DIAGRAM A830-2

COLLINS A830-2 10-WATT DIRECT FM EXCITER

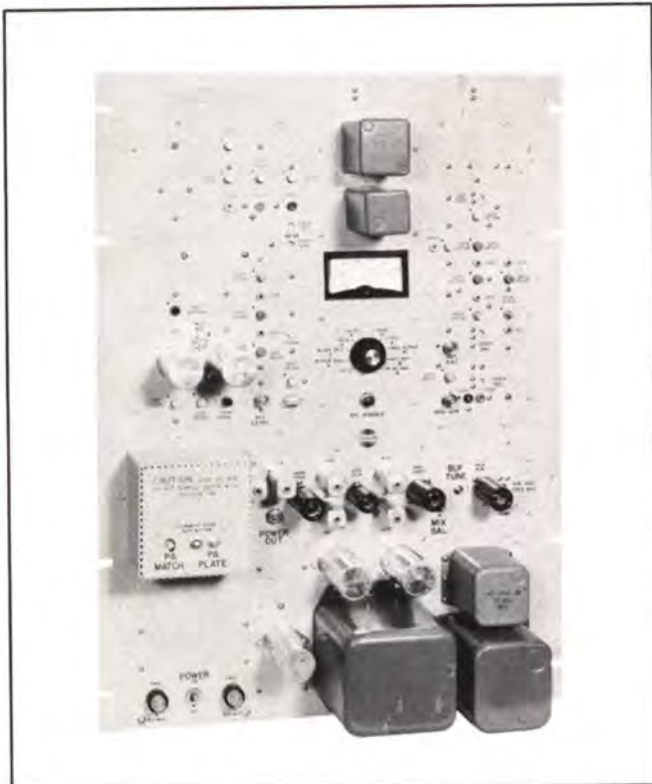

An ideal, independent unit that may be used in educational stations or for other similar low power applica-

tions, the Collins A830-2 is a 10-watt direct FM exciter that accepts audio inputs from a monophonic, stereo (see Collins FM Stereo Multiplex Generator description, or SCA source by telephone lines or direct connection and modulates an existing carrier to provide an RF drive signal for direct transmission or further amplification. The unit serves as the exciter portion of the Collins 830B-1A and 830E-1A FM Transmitters (see descriptions) and may be rack mounted in 10-watt installations.

Power Source: 117 v ac $\pm 5\%$, 50-60 cps, single phase.

Power Supply Voltages:

+ 20 v dc ± 0.1 v, regulation ± 0.1 v; ripple 0.5%.

- 10 v dc ± 0.1 v, regulation ± 0.1 v; ripple 0.5%.

+ 300 v dc ± 5.0 v, regulation ± 10 v; ripple 1%.

Carrier Frequency Stability: Not more than $\pm 2,000$ cps.
FM Noise Level: 65 db below 100% modulation (± 75 kc).

AM Noise Level (RMS): 55 db below 100% AM level.

Tube Complement (one each):

6U8 6AU6

12AT7 5763

2E26

Size: 19" W, 26 $\frac{1}{4}$ " H, 3 $\frac{3}{8}$ " D (48.26 cm W, 66.68 cm H, 8.57 cm D).

Weight: 42 lbs. (19.05 kg).

Part No. 522 2714

Consists of 10-watt exciter, set of tubes, transistors, power rectifiers, crystal and instruction book. Rack mounted unit.

No Part Number

Complete set of spare tubes, plug-in transistors plus power rectifiers for 830A-2.

No Part Number

FCC set of spare tubes, plug-in transistors plus power rectifiers for 830A-2.

No Part Number

Spare crystal operating frequency for A830-2 10-watt exciter.

Part No. 289 2743 00

Spare 14 mc crystal.



COLLINS 830B-1A FM TRANSMITTER

Designed for top reliability and superior quality sound, the Collins 830B-1A 250 Watt FM Transmitter not only affords the broadcaster an economical, self-contained unit, but also is readily adaptable to a variety of uses, including stereophonic FM and increased station power.

Clean, sharp lines plus "humanized" engineering for both operation and maintenance make the Collins 830B-1A an attractive, integrated unit in the most modern broadcast station.

Other quality features of the Collins 830B-1A which underscore its superior performance include:

SELF-CONTAINED — Transformers for the all solid state power supply as well as the harmonic filter are housed

inside the cabinet. Self-contained multiplexing equipment, including the Collins 786M-1 Stereo Generator, also may be installed inside. Space is provided for power transformers when the unit is used as a driver for the 830E-1A 5,000 Watt Transmitter.

SIMPLE OPERATION — The 830B-1A is pushbutton operated, featuring a "step-start" system in which starting sequences are fully automatic. All RF circuits are tuned from the front panel. Adequate metering is provided for rapid operation analysis. All adjustments can be made while the transmitter is on the air.

DEPENDABLE — The compact transmitter uses space-saving silicon rectifiers which generate a minimum of

heat. Spurious radiation is minimized and the unit has a high degree of stability.

MAINTENANCE EASE — Vertical panel construction eliminates hidden components and allows rapid inspection and maintenance. Cabinet interlocks minimize danger during circuitry inspection and maintenance. A grounded shorting stick is readily accessible to discharge capacitors before transmitter servicing.

RIGID TESTING — In accordance with rigid Collins standards, the 830B-1A is tested on the broadcaster's channel under proper load conditions prior to shipment.

The 830B-1A can meet a variety of power situations. Only the blower motor need be changed to convert from the nominal 60 cycle to 50 cycle operation.

Frequency Range: 88-108 mc.

Power Output: 250 watts.

Carrier Frequency Stability: ± 1000 cps.

Audio Frequency Response: ± 1 db, 50-15,000 cps.

Distortion: Less than 1%, 50-15,000 cps.

FM Noise Level: 65 db below ± 75 kc.

AM Noise Level: -55 db rms.

Harmonic Attenuation: At least -67 db.

Modulation Capability: ± 100 kc.

RF Output Impedance: 50 ohms; SWR not to exceed 2:1.

Audio Input Level: +10 dbm, ± 2 db.

Power Source: 230 v ac nominal, 60 cps, 1 phase (tapped for 200-250 v in 10 v steps).

Input Power Requirement: 860 watts, 90% power factor.

Power Line Regulation: 3%.

Variations: Slow line, $\pm 5\%$; rapid line, $\pm 3\%$.

Tube Complement:

2 OD3	1 5763
1 6U8	1 2E26
1 12AT7	1 4CX250B
1 6AU6	

Temperature Range: 15° - 45°C.

Humidity: 0% - 95%.

Altitude: 6000 ft. (1828.8 m).

Size: 38" W, 76" H, 27" D (96.52 cm W, 193.04 cm H, 68.58 cm D).

Weight: 638 lbs. (289.4 kg).

Part No. 522 2871

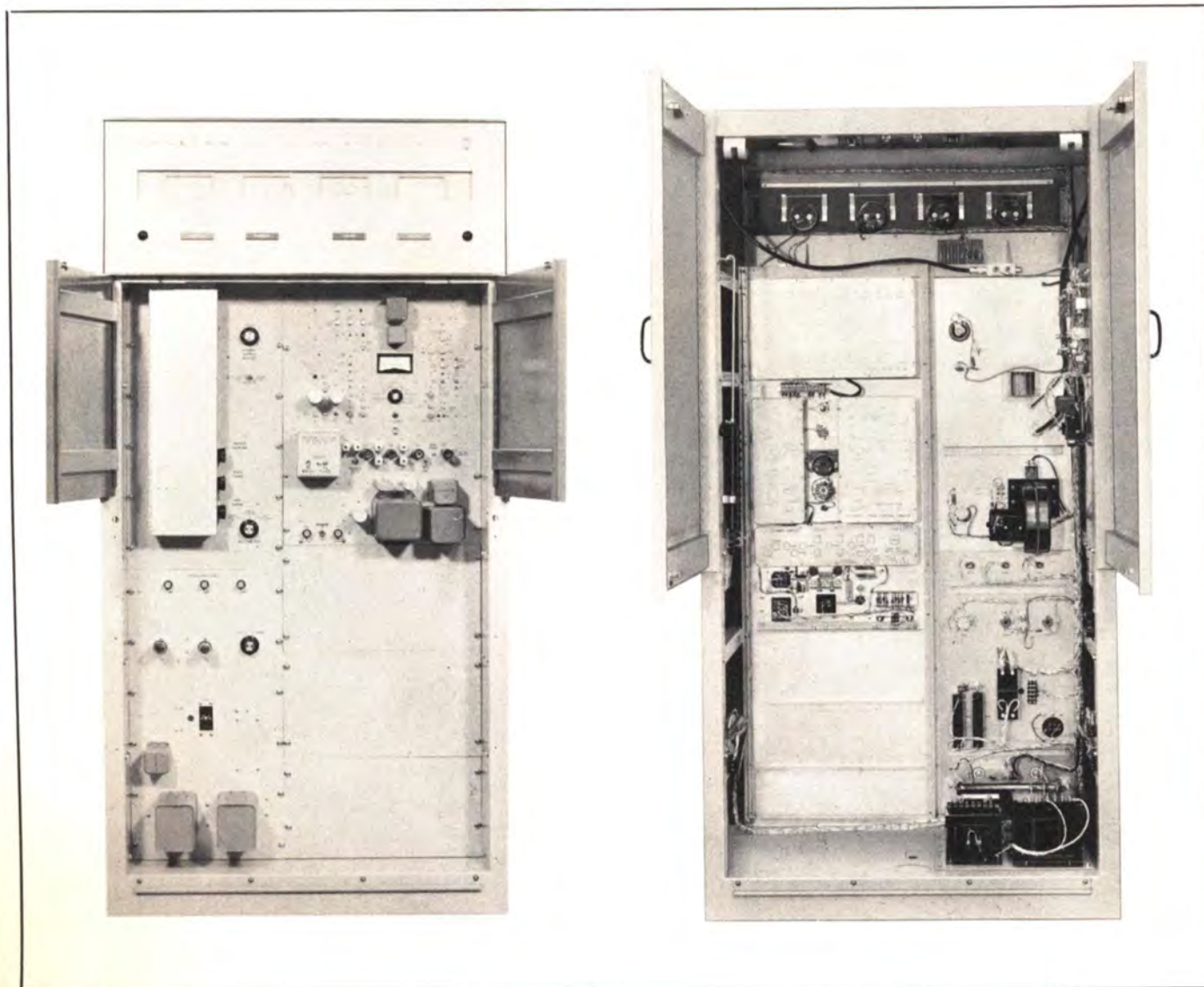

830B-1A FM TRANSMITTER

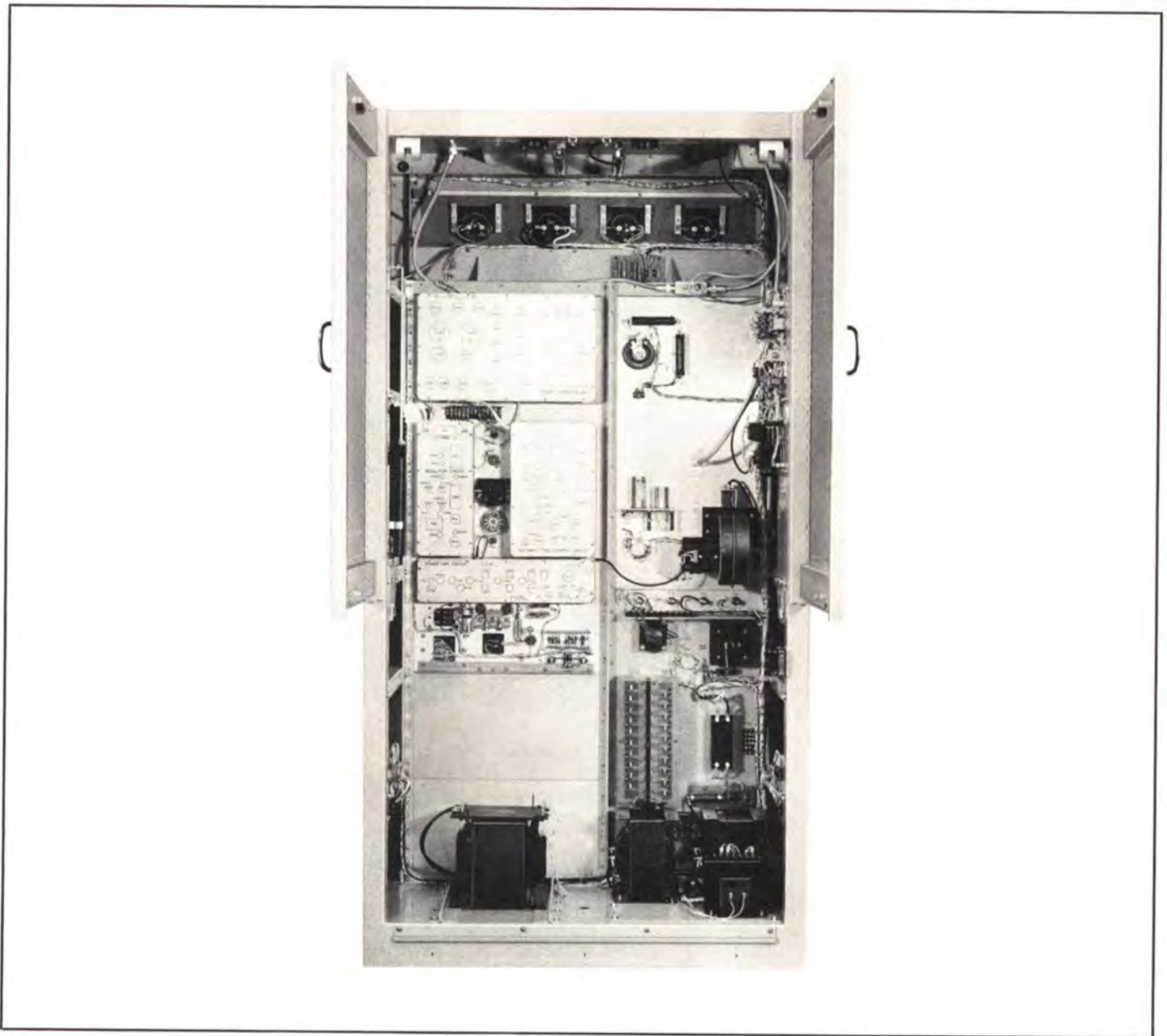

COLLINS 830D-1A FM TRANSMITTER

Carefully-engineered design, straight-forward circuitry, clean-line cabinetry all make the Collins 830D-1A FM Transmitter a powerful and versatile installation in the most modern station.

The self-contained 1,000 watt unit achieves a new degree of reliability and operational ease never before obtainable by the FM broadcaster.

The new approach A830-2 10 Watt Exciter is the heart of the 830D-1A. This wide band direct FM unit accepts a composite stereo signal directly without using auxiliary modulators for either the stereo or SCA channels.

Operation and maintenance of the Collins 830D-1A is simplicity itself. Fewer components and fewer tuned circuits enhance the dependability and operational ease of the transmitter.

Some of its features are:

SELF-CONTAINED — Transformers for the all solid state power supply as well as the harmonic filter are enclosed in the cabinet. Self-contained multiplexing equipment, including the Collins 786M-1 Stereo Generator, also may be mounted inside.

SIMPLE OPERATION — The 830D-1A is pushbutton operated, featuring a "step-start" system in which starting sequences are fully automatic. All RF circuits are tuned from the front panel. Adequate metering is provided for rapid operational analysis. All adjustments can be made while the transmitter is on the air.

DEPENDABLE — Space-saving silicon rectifiers which generate a minimum of heat are employed. A regulated

filament transformer prolongs tube life. Stability is enhanced through the neutralized final power amplifier. Spurious radiation is held to a minimum; the entire unit has a high degree of stability.

MAINTENANCE EASE — Vertical panel construction eliminates hidden components and allows rapid inspection and maintenance. Cabinet interlocks minimize danger during circuitry inspection and maintenance. A grounded shorting stick is readily accessible to discharge capacitors before transmitter servicing.

RIGID TESTING — In accordance with rigid Collins standards, the 830D-1A is tested on the broadcaster's channel under proper load conditions *before* shipment is made.

The 830D-1A can meet a variety of power situations. Not a single component need be changed to convert from nominal 60 cycle operation to 50 cycle.

Frequency Range: 88-108 mc.

Power Output: 1000 watts.

Carrier Frequency Stability: ± 1000 cps.

Audio Frequency Response: ± 1 db, 50-15,000 cps.

Distortion: Less than 1%, 50-15,000 cps.

FM Noise Level: 65 db below ± 75 kc.

AM Noise Level: -55 db rms.

Harmonic Attenuation: -73 db.

Modulation Capability: ± 100 kc.

RF Output Impedance: 50 ohms; SWR not to exceed 2:1.

Audio Input Level: +10 dbm, ± 2 db.

Power Source: 230 v ac nominal, 50-60 cps, 1 phase (tapped for 200-250 v in 10 v steps).

Input Power Requirement: 2300 watts, 90% power factor.

Power Line Regulation: 3%.

Variations: Slow line, $\pm 5\%$, rapid line, $\pm 3\%$.

Tube Complement:

1 6U8	1 5763
1 12AT7	1 2E26
1 6AU6	1 4CX1000A

Temperature Range: 15° - 45°C.

Humidity: 0% - 95%.

Altitude: 6000 ft. (1828.8 m).

Size: 38" W, 76" H, 27" D (96.52 cm W, 193.04 cm H, 68.58 cm D).

Weight: 776 lbs. (351.99 kg).

Part No. 522 2969

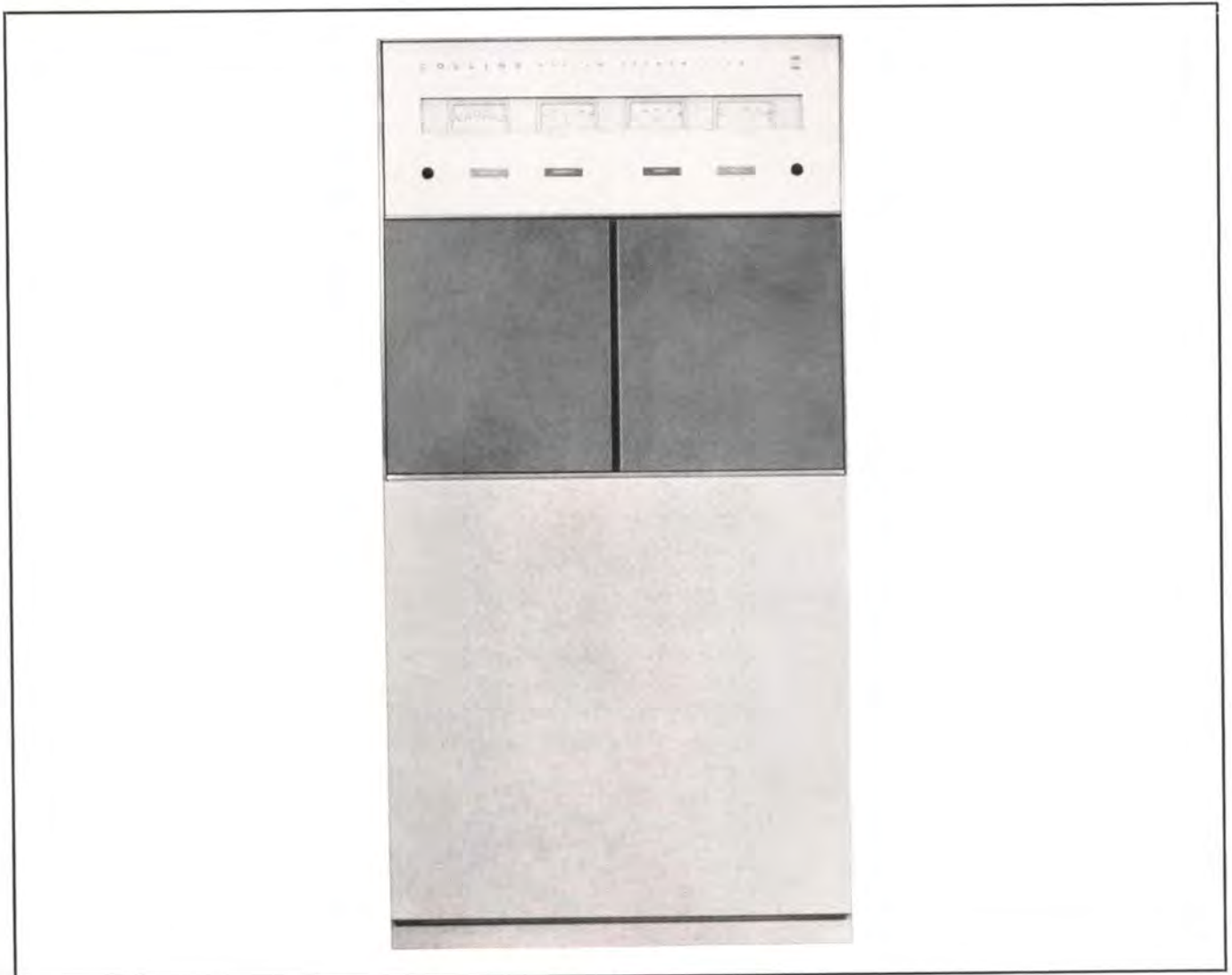

830D-1A FM TRANSMITTER



COLLINS 830E-1A 5,000 WATT FM TRANSMITTER

Award-winning design and "humanized" engineering, hallmarks of Collins quality, are reflected in the Collins 830E-1A 5,000 Watt FM Transmitter.

One cabinet houses the A830-2 Direct FM Exciter and the 250 watt B830-1 Driver Unit; the other houses the 5,000 watt, single stage transmitter.

Features of the Collins 830E-1A are:

SELF-CONTAINED—Every component is housed inside the two cabinets, including power transformers, harmonic filter and directional coupler. An optional accessory is the Collins 786M-1 Stereo Generator which fits inside the driver unit cabinet. Installation of the 786M-1 is a matter of minutes.

SIMPLE OPERATION—The transmitter is pushbutton operated, featuring a "step-start" system in which starting sequences are fully automatic. Highly stable RF circuits

are tuned and metered from the front panel, and all adjustments can be made while the transmitter is on the air. No tuning or trimming of the harmonic filter is required. The PA stage is easily neutralized and is not critical in adjustment.

DEPENDABLE—Grounded screen, eliminating the screen bypass capacitor, does away with a common source of failure. Driver power supply uses silicon rectifiers which take little space and generate a minimum of heat. Efficient blowers force air directly on the 4CX250B and 4CX5000A power amplifier tubes. Power supply is all solid state with the exception of the final amplifier plate voltage supply which uses mercury vapor rectifiers.

MAINTENANCE EASE—Vertical panel construction eliminates hidden components and allows rapid inspection and maintenance. Cabinet interlocks minimize danger during

circuitry inspection and maintenance. A grounded shorting stick is readily accessible to discharge capacitors before transmitter servicing.

RIGID TESTING—In keeping with rigid Collins standards, the 830E-1A is tested on the broadcaster's channel under proper load conditions *before* the unit is shipped.

While the transmitter nominally operates on 60 cycle power, only the two blower motors need be changed to convert to 50 cycle operation.

Frequency Range: 88-108 mc.

Power Output: 5000 watts.

Carrier Frequency Stability: ± 1000 cps.

Audio Frequency Response: ± 1 db, 50-15,000 cps.

Distortion: Less than 1%, 50-15,000 cps.

FM Noise Level: 65 db below ± 75 kc.

AM Noise Level: -55 db rms.

Harmonic Attenuation: -80 db.

Modulation Capability: ± 100 kc.

RF Output Impedance: 50 ohms; SWR not to exceed 2:1.

Audio Input Level: +10 dbm, ± 2 db.

Power Source: 230 v ac, 60 cps, 3 phase (tapped for 200-250 v in 10 v steps).

Input Power Requirement: 11 kw, 90% power factor.

Power Line Regulation: 3%.

Variations: Slow line, $\pm 5\%$; rapid line, $\pm 3\%$.

Tube Complement:

2 OD3	1 2E26
1 6U8	1 4CX250B
1 12AT7	6 872A*
1 6AU6	1 4CX5000A
1 5763	

Temperature Range: 15° - 45°C.

Humidity: 0% - 95%.

Altitude: 6000 ft. (1828.8 m).

Size: 76" W, 76" H, 27" D (193.04 cm W, 193.04 cm H, 68.58 cm D).

Weight: 1800 lbs. (816.48 kg).

*Not used if silicon diode rectifiers are employed.

Part No. 522 2872

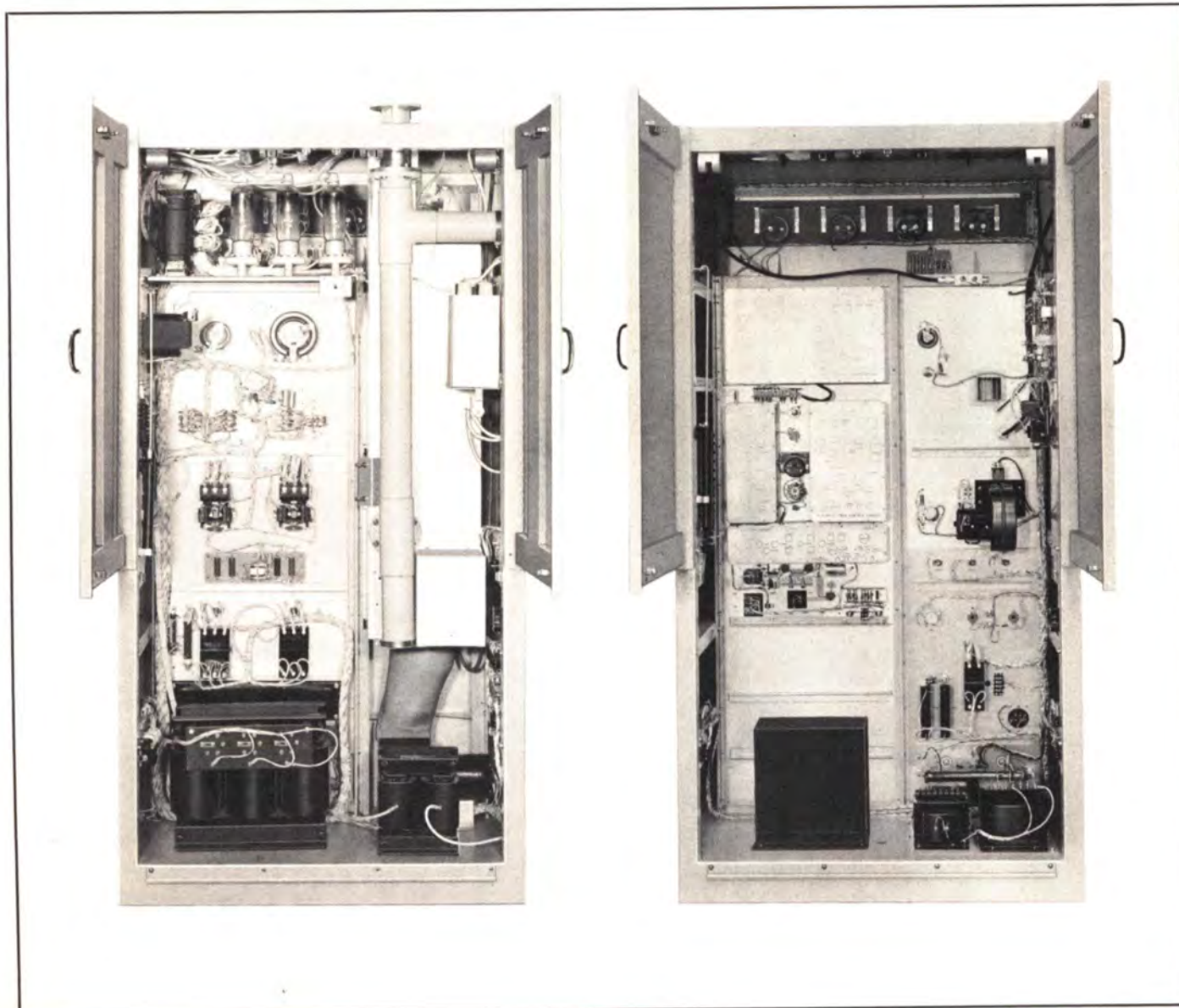

POWER AMPLIFIER REAR VIEW

DRIVER REAR VIEW

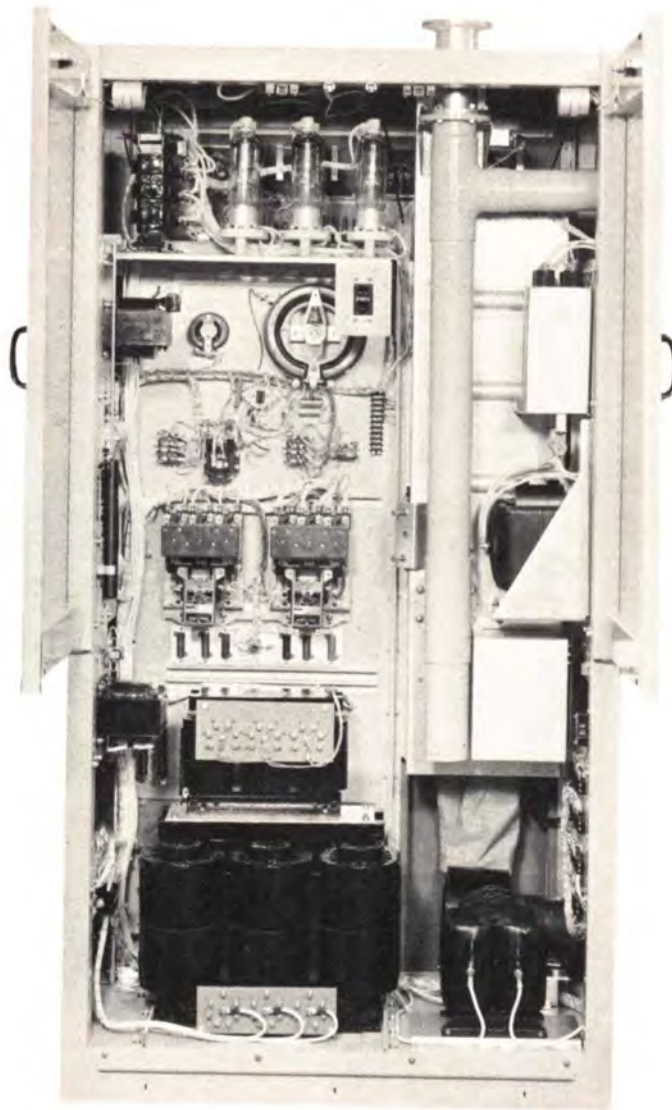

POWER AMPLIFIER REAR VIEW

COLLINS 830F-1A/10 KW FM TRANSMITTER

The Collins 830F-1A 10 KW FM Transmitter assures the broadcaster the clean, strong signal he needs to make his programming outstanding in a highly competitive market area and the extended coverage required to build and maintain an audience.

Like all Collins FM transmitters, the two-cabinet 10,000 watt model is carefully engineered and manufactured to a quality level that is a hallmark at Collins.

SELF-CONTAINED — Every component is housed within the two cabinets, including power transformers, harmonic filters and directional coupler. An optional feature is the Collins 786M-1 Stereo Generator which mounts in minutes in the 250 watt driver cabinet.

EASE OF OPERATION — Pushbutton operated, the transmitter starting sequences are fully automatic by the “step-

start” system. RF circuits are tuned and metered at the front panel. All adjustments can be made while the transmitter is on the air. No tuning or trimming of the harmonic filter is required. The PA stage is easily neutralized and is noncritical in adjustment.

DEPENDABLE — Grounded screen eliminates the bypass capacitors, doing away with a common source of failure. The driver power supply uses solid state silicon rectifiers which generate little heat and require a minimum of space. The final amplifier plate voltage supply uses mercury vapor tubes or optional silicon diode rectifiers. Efficient blowers force cooling air directly on the power tubes.

MAINTENANCE EASE — All components are easily accessible and may be rapidly inspected through the use of

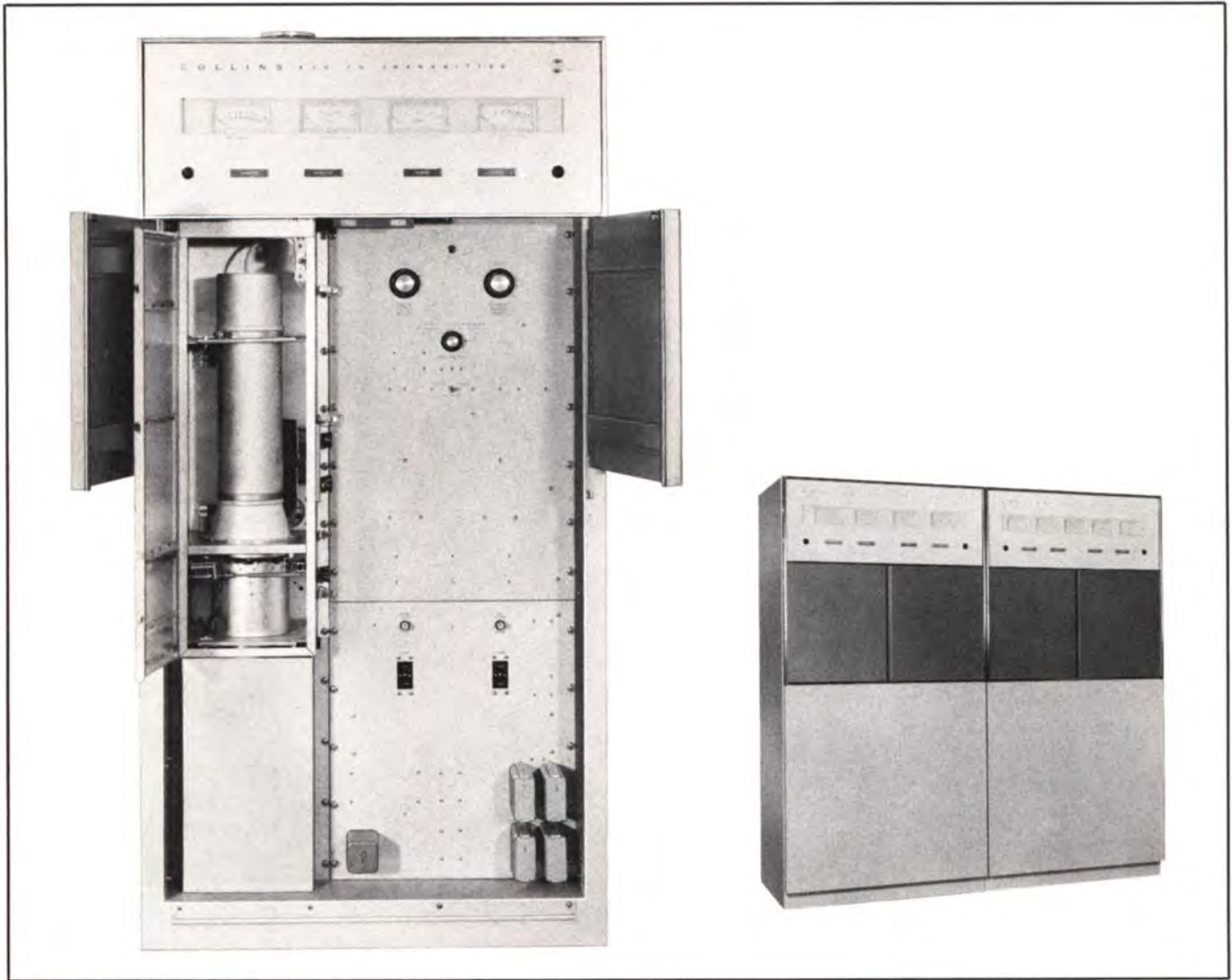

POWER AMPLIFIER FRONT VIEW

vertical panels. All panels are interlocked for safety; a grounded shorting stick is provided.

RICID TESTING — In keeping with rigid Collins standards, the transmitter is tested under actual load conditions on the broadcaster's channel before the unit is shipped.

While the transmitter is designed for 60 cycle operation, only the blower motors and plate contactors need be changed for 50 cycle use.

Collins also manufactures the 830F-2A transmitter. This unit uses an 830D-1A 1,000 watt driver, required when the additional PA is installed for 20,000 watt operation. If an eventual increase to 20KW is planned, the 830F-2A should be installed initially.

Frequency Range: 88-108 mc.

Power Output: 3,000-10,000 watts nominal.

Carrier Frequency Stability: $\pm 2,000$ cps.

Audio Frequency Response: ± 1 db, 50-15,000 cps.

Distortion: Less than 1%, 50-15,000 cps.

FM Noise Level: 65 db below ± 75 kc.

AM Noise Level: -55 db rms.

Harmonic Attenuation: -80 db.

Modulation Capability: ± 100 kc.

RF Output Impedance: 50 ohms; SWR not to exceed 2:1.

Audio Input Level: +10 dbm, ± 2 db.

Power Source: 230 v ac, cps (50 cps optional), 3 phase (tapped for 200-250 v in 10 v steps).

Input Power Requirement: 20 kw, 90% power factor.

Power Line Regulation: 3%.

Variations: Slow line, $\pm 5\%$; rapid line, $\pm 3\%$.

Tube Complement:

2 OD3	1 2E26
1 6U8	1 4CX250B
1 12AT7	6 872A*
1 6AU6	1 4CX5000A
1 5763	

Temperature Range: 20° - 45°C with mercury vapor rectifiers. 10° - 45°C with silicon diode rectifiers.

Humidity: 0% - 95%.

Altitude: 6,000 ft. (1828.8 m).

Size: 76" W, 76" H, 27" D (193 cm W, 193 cm H, 68.6 cm D).

Weight: 1,900 lbs. (861.8 kg).

*Not used if silicon diode rectifiers are employed.

Part No. 522 3054

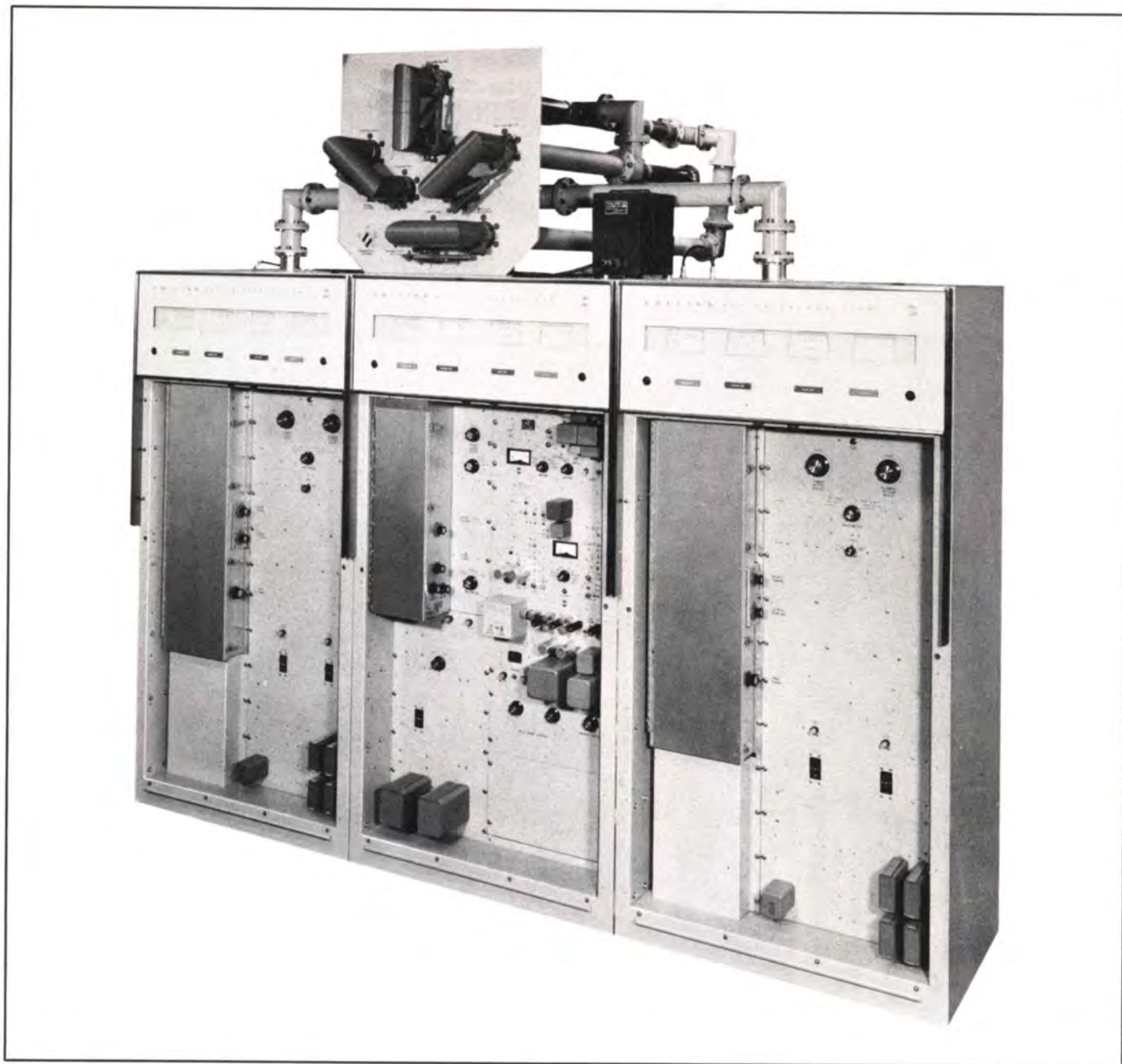

COLLINS 830H-1A/20 KW FM TRANSMITTER

For the broadcaster requiring extended coverage in major markets, Collins offers the 830H-1A, a 20,000 watt FM transmitter contained in only three cabinets. Use of a diplexing system assures continuous duty even though one of the two power amplifiers is removed from service for routine maintenance or repair.

Careful engineering, use of conservatively-rated components and precision manufacturing techniques assure the broadcaster of quality upon which he can depend.

Outstanding benefits of the 830H-1A are:

SELF-CONTAINED — Every component, including power transformers, harmonic filters and directional couplers, are housed within the three cabinets. Only the diplexer

assembly is mounted on the exterior. While the photograph shows a top mounted diplexer, this assembly may be located anywhere convenient to the broadcaster. An optional accessory is the 786M-1 Stereo Generator, which mounts in minutes inside the driver cabinet.

SIMPLE OPERATION — A pushbutton-operated "step-start" system assures automatic starting sequencing. RF circuits, tuned and metered at the front panel, may be adjusted while the transmitter is on the air. The harmonic filter requires no tuning or trimming. The PA stage is neutralized easily and is noncritical in adjustment.

DEPENDABLE — In event of a PA outage, the transmitter remains on the air at 6 db lower output until the an-

tenna is patched to one amplifier to permit half-power (-3 db) operation while the disabled PA is being restored to service. The transmitter is not off the air during this operation. A grounded screen eliminates the bypass capacitors, common trouble points. Independent driver power supply is solid state, requiring little space and generating little heat. The PA power supply consists of mercury vapor tubes, with a solid state supply an optional feature. Efficient, quiet blowers force air directly on the 4CX1000A and two 4CX5000A power amplifier tubes.

MAINTENANCE EASE — All components are easily accessible for inspection and maintenance through vertical panel construction. All cabinet panels are interlocked for safety; a grounded shorting stick is installed in each cabinet to discharge capacitors before servicing.

RIGID TESTING — The 830H-1A, like all Collins transmitters, is tested on the broadcaster's channel under actual load conditions *before* shipment.

While the transmitter nominally operates on 60 cycles, only the blower motors and plate contactors need be changed for 50 cycle operation.

Frequency Range: 88-108 mc.
Power Output: 6,000-20,000 watts nominal.
Carrier Frequency Stability: $\pm 2,000$ cps.
Audio Frequency Response: ± 1 db, 50-15,000 cps.
Distortion: Less than 1%, 50-15,000 cps.
FM Noise Level: 65 db below ± 75 kc.
AM Noise Level: -55 db rms.
Harmonic Attenuation: -80 db.

Modulation Capability: ± 100 kc.
RF Output Impedance: 50 ohms; SWR not to exceed 2:1.
Audio Input Level: +10 dbm, ± 2 db.
Power Source: 230 v ac, 60 cps (50 cps optional), 3 phase (tapped for 200-250 v in 10 v steps).
Input Power Requirement: 40 kw, 90% power factor.
Power Line Regulation: 3%.
Variations: Slow line, $\pm 5\%$; rapid line, $\pm 3\%$.

Tube Complement:

1 6U8	1 2E26
1 12AT7	1 4CX1000A
1 6AU6	12 872A*
1 5763	2 4CX5000A

Temperature Range: 20° - 45°C with mercury vapor rectifiers; 10° - 45°C with silicon diode rectifiers.

Humidity: 0% - 95%.

Altitude: 6,000 ft. (1828.8 m).

Size: 114" W, 76" H, 27" D (289.6 cm W, 193 cm H, 68.6 cm D).

Weight: 2,900 lbs. (1315 kg).

*Not used if silicon diode rectifiers are employed.

Part No. 522 3055

830N-1A FM TRANSMITTER

For the broadcaster whose market includes extensive mobile reception, Collins sells the 830N-1A, a dual 10,000 watt transmitter. This unit transmits 10,000 watts through vertically polarized antennas for automobile receivers and 10,000 watts to the horizontally-polarized antennas for home receivers.

Part No. 522 3592

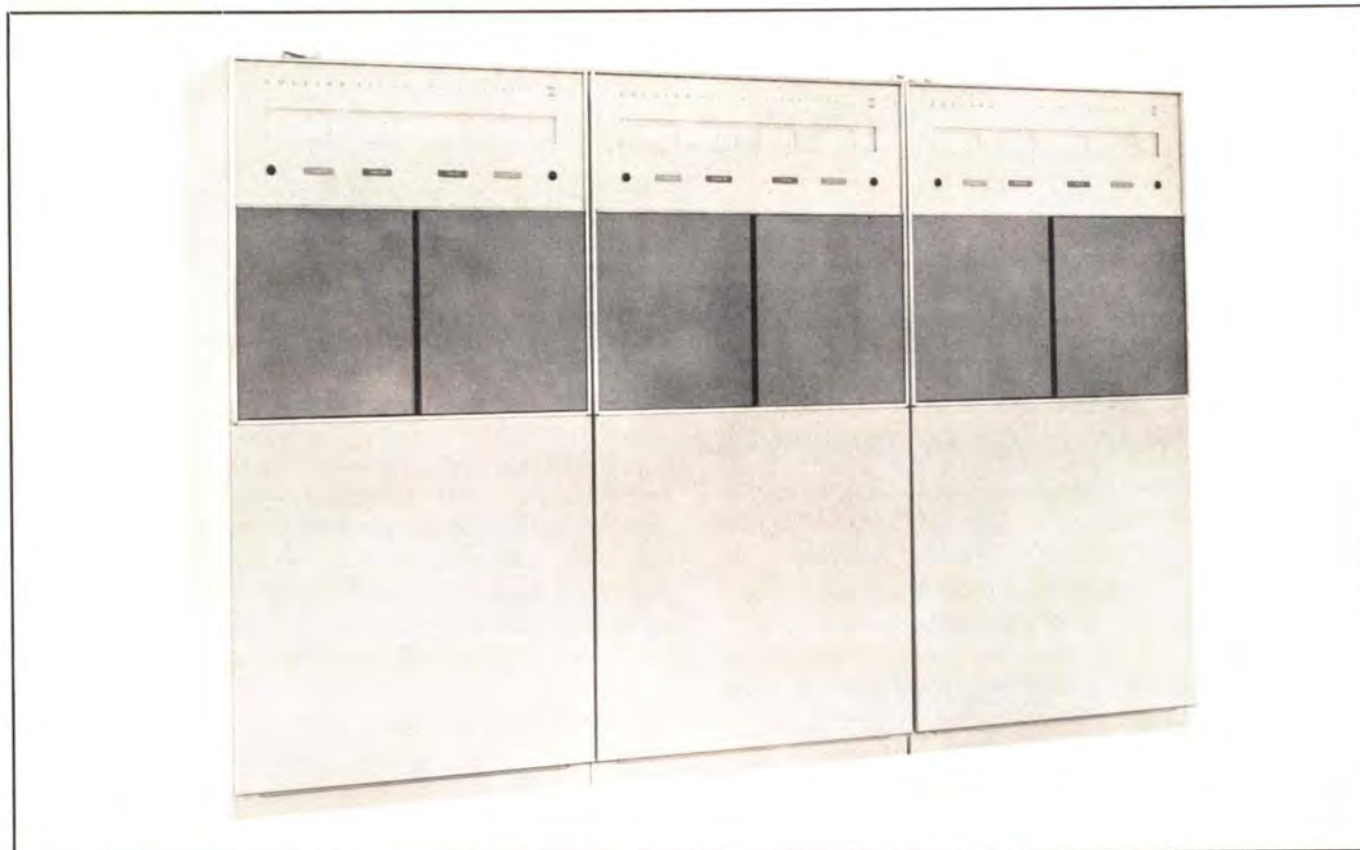

830H-1A FM TRANSMITTER

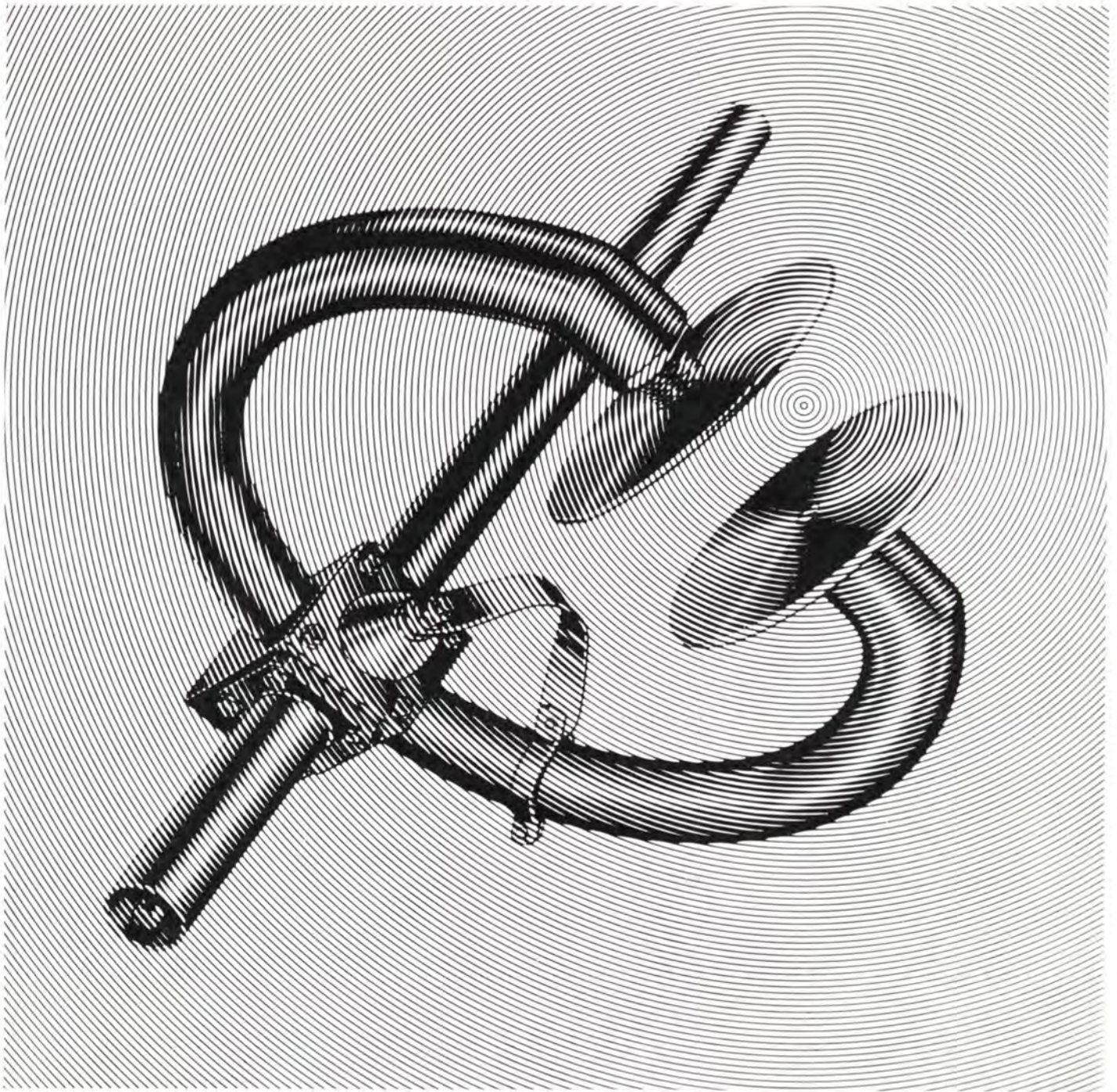

ANTENNAS, TOWERS, TRANSMISSION LINES

If You Didn't Get This From My Site,
Then It Was Stolen From...

www.SteamPoweredRadio.Com

COLLINS 37M FM ANTENNA



A proven design that has been imitated but never duplicated in efficiency during the past decade, the Collins 37M Antenna still maintains its position of leadership in FM broadcasting.

The advanced design features of the unit make it an ideal antenna for stereo and multiplex operations. The aerodynamic simplicity and low weight of the 37M provide greater efficiencies and savings in new tower costs, erection time and maintenance expense. These features also eliminate undue oscillating and weaving of the tower and antenna.

The Collins 37M Ring Antenna consists of only two basic parts: the radiating ring and the connecting inter-ring transmission line. Any number of rings, either odd or even, may be used to provide maximum flexibility in high power gain.

Antenna arrays mounted on $1\frac{5}{8}$ " or $3\frac{1}{8}$ " line are available for handling transmitter powers up to 20 kw. Antenna assemblies on $1\frac{5}{8}$ " line are rated for power inputs at base of antenna up to 3 kw for a single ring array; 10 kw for four or more rings. Antenna assemblies on $3\frac{1}{8}$ " line are rated for power inputs up to 3 kw per ring at base of antenna with maximum of 20 kw for seven or more rings.

Only one inter-element transmission line is required to feed all rings in a multiple element array. The individual radiating rings are identical mechanically and electrically. They are both shunt fed and supported by a single interconnecting feed line, which consists of modified lengths of standard EIA rigid coaxial line insulated with Teflon. The Collins 37M FM Antenna feed system has a stub at the top of the array which is capacitive and adequately removes the inductive reactance created by the shunt feed on the ring. The 37M terminates in a standard EIA 50 ohm flange connection on the bottom element of

the array for coupling directly to $1\frac{5}{8}$ " or $3\frac{1}{8}$ " transmission line.

The horizontal radiation pattern of the Collins 37M FM Antenna is essentially circular for both top mounting and side mounting arrays. A maximum deviation of only 1 db is obtained in the top mounted arrangement, while the circular pattern of the side mounted array will generally equal that of the top mounted antenna. The extent of deviation from a circular pattern in the side mounted antenna is dependent on the type and size of tower on which the antenna is mounted. In cases of very large supporting structures and in all cases where guy wires are used, expert recommendations should be requested on spacing of insulators and guy wires and mounting of the antenna. Insulators should be placed where the guys attach to the tower and guys should also be broken with insulators approximately every three feet for 15 feet in the immediate area of the antennas.

The voltage standing wave ratio of the Collins 37M Antenna can be maintained at better than 1.1:1 due to the inherently high stability of the tuning system. The capacitor plates of the 37M are adjustable for optimum performance and equal power distribution through all rings. These features allow an accurate prediction of the gain from the given number of loops in the array. Adequate bandwidth virtually eliminates detuning effects caused by changes in atmospheric conditions. The bandwidth and linearity of the antenna are more than adequate for multiplexing service.

The compactness and simplicity of the 37M allow maximum efficiency in ice removal. Each ring may be equipped with an internally mounted, 200-watt heating unit which consists of a cartridge type element inside each of the tuning capacitor plates and an additional flexible heating element extending the full circumference of the inside of the ring. The simplicity of the heating arrangement makes it possible to replace the elements in the field if necessary. The absence of large masses of metal assures efficient and practical deicing of the antenna and capacitor, which is the most critical part of the antenna when icing occurs.

The 37M Antenna is easy and quick to erect. There are no heavy hoisting problems so that many hours of erection time can be saved. Support brackets are specially fabricated for each installation to match the tower and mounting arrangement, thus minimizing erection problems at the site.

Either guyed or self-supporting towers will in nearly all cases support the side mounting 37M. Towers which support top mounting television antenna arrays increase their usefulness with the addition of a side mounting 37M Antenna.

Top or pole mounting design is available on special order for installation on towers where no TV antenna is present or planned. This type of mounting provides the maximum in height and coverage. The light weight and windloading of the top mounting series allows erection on

most guyed and self-supporting towers without extensive tower modification.

Further information and quotations on the 37M FM Directional Antenna will be supplied upon request.

Part No.	Type and Number of Rings	Part No.	Type and Number of Rings
013 0020	37M-1	013 0070	37M-6
013 0030	37M-2	013 0080	37M-7
013 0040	37M-3	013 0090	37M-8
013 0050	37M-4	097 1693	37M-10
013 0060	37M-5	097 1528	37M-12

For top mounted, with mast rings mounted on 1 1/8" Line or 3 1/8" Line, Part Number remains the same for the specified number of rings.

No Part Number
37M FM Antennas for power inputs over 20 kw.
Part No. 013 0099
Deicer per bay installed at the factory.
Part No. 099 0005 00
Replacement heating element. Two required per ring.

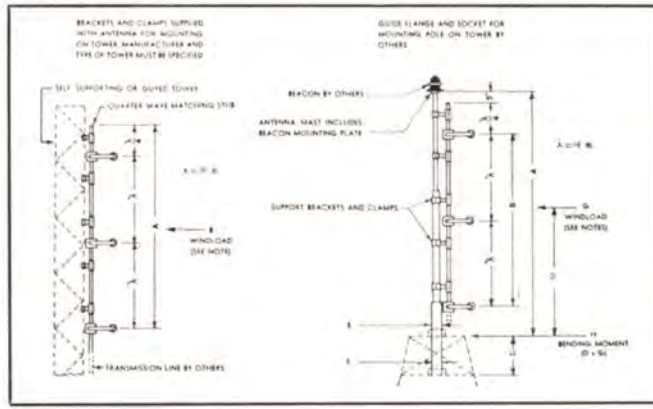

COLLINS 37-M ANTENNA — SIDE MOUNTED

Collins Type	No. of Rings	Power Gain	Field Gain	db Gain	A**		On 1 1/8" Line		On 3 1/8" Line	
					Feet	Inches	B***	Weight (lbs.)	B***	Weight (lbs.)
37M-1	1	0.9	.95	- 0.45	2'	5"	43	42	81	69
37M-2	2	2.0	1.41	3.01	12	3	125	91	234	155
37M-3	3	3.0	1.73	4.77	22	1	206	140	386	241
37M-4	4	4.1	2.02	6.13	31	10	288	189	538	327
37M-5	5	5.2	2.28	7.16	41	8	370	238	691	413
37M-6	6	6.3	2.51	7.99	51	5	451	287	843	499
37M-7	7	7.3	2.70	8.63	61	3	533	336	996	585
37M-8	8	8.4	2.90	9.24	71	0	614	385	1148	671
37M-9*	9	9.4	3.07	9.73	80	10	696	434	1300	757
37M-10*	10	10.5	3.24	10.21	90	7	778	483	1453	843
37M-12*	12	12.5	3.54	10.97	110	3	941	581	1758	1015
37M-14*	14	14.5	3.81	11.61	129	10	1104	679	2062	1187
37M-16*	16	16.5	4.06	12.17	149	5	1267	777	2367	1359

* Antennas of over 8 bays are center fed with even numbers of bays or at 1/2 bay separation below center with odd numbers of bays.
** Computed for 100 Mc. For other frequencies multiply by 100 divided by frequency in Mc/s.
*** Wind loads based on 60 pounds on flat surfaces, 40 pounds per square foot on projected areas of cylindrical surfaces with all sections considered round.

COLLINS 37-M ANTENNA — TOP MOUNTED

Collins Type	No. of Rgs.	Pwr. Gn.	On 1 1/8" Line										On 3 1/8" Line				
			A Fr.	B Fr.	C Fr.	D Fr.	E Dia.	F Dia.	G Lbs.	H Fr.-Lbs.	Dead Wt.	D Fr.	E Dia.	F Dia.	G Lbs.	H Fr.-Lbs.	Dead Wt.
37M-1	1	.9	6		3	4-7	3 1/8"	3 1/8"	50	230	223	4-7	3 1/8"	3 1/8"	68	312	250
37M-2	2	2.0	16	10±	4	10	4 1/2"	4 1/2"	239	2,390	305	12-3	4 1/2"	4 1/2"	291	3,565	360
37M-3	3	3.0	26	20±	7	14-5	6 3/8"	6 3/8"	403	5,803	736	14-4	6 3/8"	6 3/8"	486	6,950	825
37M-4	4	4.1	36	30±	10	19	7 7/8"	7 7/8"	564	10,716	1169	18-9	7 7/8"	7 7/8"	678	12,713	1290
37M-5	5	5.2	46	40±	12	23	8 5/8"	7 7/8"	747	17,181	1652	22-8	9 3/8"	9 3/8"	919	20,769	2128
37M-6	6	6.3	56	50±	14	27-2	9 3/8"	8 5/8"	951	25,867	2285	26-7	10 3/8"	9 3/8"	1173	31,260	2770
37M-7	7	7.3	66	60±	15	31	10 3/8"	8 5/8"	1175	36,425	3218	31-3	10 3/8"	8 5/8"	1388	43,375	3485
37M-8*	8	8.4	76	70±	16-6	34-9	11 3/8"	9 3/8"	1417	49,241	4051	34-8	12 3/8"	11 3/8"	1696	58,682	4650

* up to 12 bays on application

ANDREW FITTINGS FOR COLLINS 37M-FM ANTENNA

The following end terminals and fittings are required for connection of various types of transmission line to Collins 37M FM Antenna. The 37M is supplied with 1 5/8" or 3 1/8" line. The following lists only Andrew fittings for antenna end of transmission line to antenna line. Be sure to specify correct fitting for transmitter end.

- ANDREW H5, 7/8" Heliax to 1 5/8" 37M: 75AR EIA Flange and 1860 Reducer (inner connectors supplied with 75AR and 1860).
- ANDREW H7, 1 5/8" Heliax to 1 5/8" 37M: 87R EIA Flange (with inner connector).
- ANDREW H7, 1 5/8" Heliax to 3 1/8" 37M: 87R EIA

- Flange (with inner connector) and 1861 Reducer.
- ANDREW H2, 3 1/8" Heliax to 3 1/8" 37M: 22R EIA Flange and 15093 Inner Connector.
- AMPHENOL RG 17U, 7/8" Solid to 1 5/8" 37M: 12418-1 Plug, 15069 Inner Connector and 2361 Adapter.
- ANDREW 740, 7/8" Semi-flexible to 1 5/8" 37M: 1860 Reducer (with inner connector).
- ANDREW 560, 7/8" Rigid to 1 5/8" 37M: 1860 Reducer (with inner connector).
- ANDREW 561, 1 5/8" Rigid to 1 5/8" 37M: 15069 Inner Connector.
- ANDREW 562A, 3 1/8" Rigid to 1 5/8" 37M: 1861 Reducer (with inner connector).
- ANDREW 562A, 3 1/8" Rigid to 3 1/8" 37M: 15093 Inner Connector.

COLLINS 300C VERTICALLY POLARIZED FM ANTENNA



SEE COVER ILLUSTRATION

Collins 300C vertically polarized FM antenna can significantly improve your FM coverage. Here's how:

FCC regulations permit simultaneous FM radiation in both horizontal and vertical planes. For example, if your

station is authorized for 5 kw ERP (horizontal), vertical radiation can be added up to the same power. Stations now operating with greater ERP than specified in new FCC rules for their classification may radiate vertically up to the maximum ERP specified in the rules.

Two methods are commonly used:

(1) A single power amplifier and transmission line to provide power for each antenna.

(2) Two power amplifiers fed from a common exciter-driver and two transmission lines. The antennas are fed separately.

The preferred method will be dictated by your power situation. If minimum initial investment is your primary concern, the first method is preferred. If redundancy is important, the second method permits either amplifier to be operated individually or both simultaneously. The recommended ratio of vertical to horizontal ERP is unity.

Collins Type 300C costs no more than your present horizontal bays, can be installed on your present tower and is compatible with your FM transmitter.

Vertical polarization with Collins 300C:

- * fills in shadow areas
- * reduces null effects
- * improves fringe area reception
- * vastly improves car FM radio reception
- * maintains FM stereo quality
- * improves SCA operation

TYPE 300C ANTENNA — SIDE MOUNTED

Type	No. of Dipoles	Power Gain	Field Gain	DB Gain	Power Rating		Length	
					On 1 3/8" Line	On 3 1/8" Line	Feet & Inches	
300-1	1	.950	.975	-.002	3	3	3	9
300-2	2	1.969	1.400	2.942	6	6	13	7
300-3	3	3.120	1.767	4.942	9	9	23	4
300-4	4	4.198	2.045	6.230	10	12	33	2
300-5	5	5.310	2.305	7.251	10	15	42	11
300-6	6	6.393	2.528	8.057	10	18	57	9
300-7	7	7.500	2.738	8.751	10	21	62	7
300-8*	8	8.571	2.926	9.330	20	24	72	4
300-9*	9	9.755	3.124	9.892	20	27	82	2
300-10*	10	10.960	3.311	10.398	20	30	91	11
300-12*	12	13.195	3.633	11.204	20	36	111	7
300-14*	14	15.290	3.910	11.844	20	42	131	2
300-16*	16	17.483	4.181	12.426	20	48	150	9

Type	Weight		Wind Load**		Over Turning Moment***	
	On 1 3/8" Line	On 3 1/8" Line	On 1 3/8" Line	On 3 1/8" Line	On 1 3/8" Line	On 3 1/8" Line
300-1	50	55	104	104	0	0
300-2	111	135	259	307	1,190	1,430
300-3	171	215	414	510	3,900	4,840
300-4	232	295	569	713	8,350	10,200
300-5	292	375	724	916	14,300	17,600
300-6	353	455	879	1119	21,100	27,000
300-7	413	535	1034	1322	29,900	38,400
300-8*	474	615	1189	1525	40,200	51,700
300-9*	534	695	1344	1728	52,100	67,100
300-10*	595	775	1499	1931	65,400	84,400
300-12*	716	935	1809	2337	96,600	125,000
300-14*	837	1095	2119	2743	133,965	173,000
300-16*	958	1255	2429	3149	177,000	230,000

* Antennas of eight bays and over are center fed with even numbers of bays or at a point 1/2 bay below center with odd numbers of bays.

** Wind load in the direction through the mounting toward the tower computed for 60 lbs. on flat surfaces and 40 lbs. on projected areas of cylindrical surfaces.

*** For 60 lbs. wind loading direction through the mounting toward the tower and referred to the center line of the bottom bay.

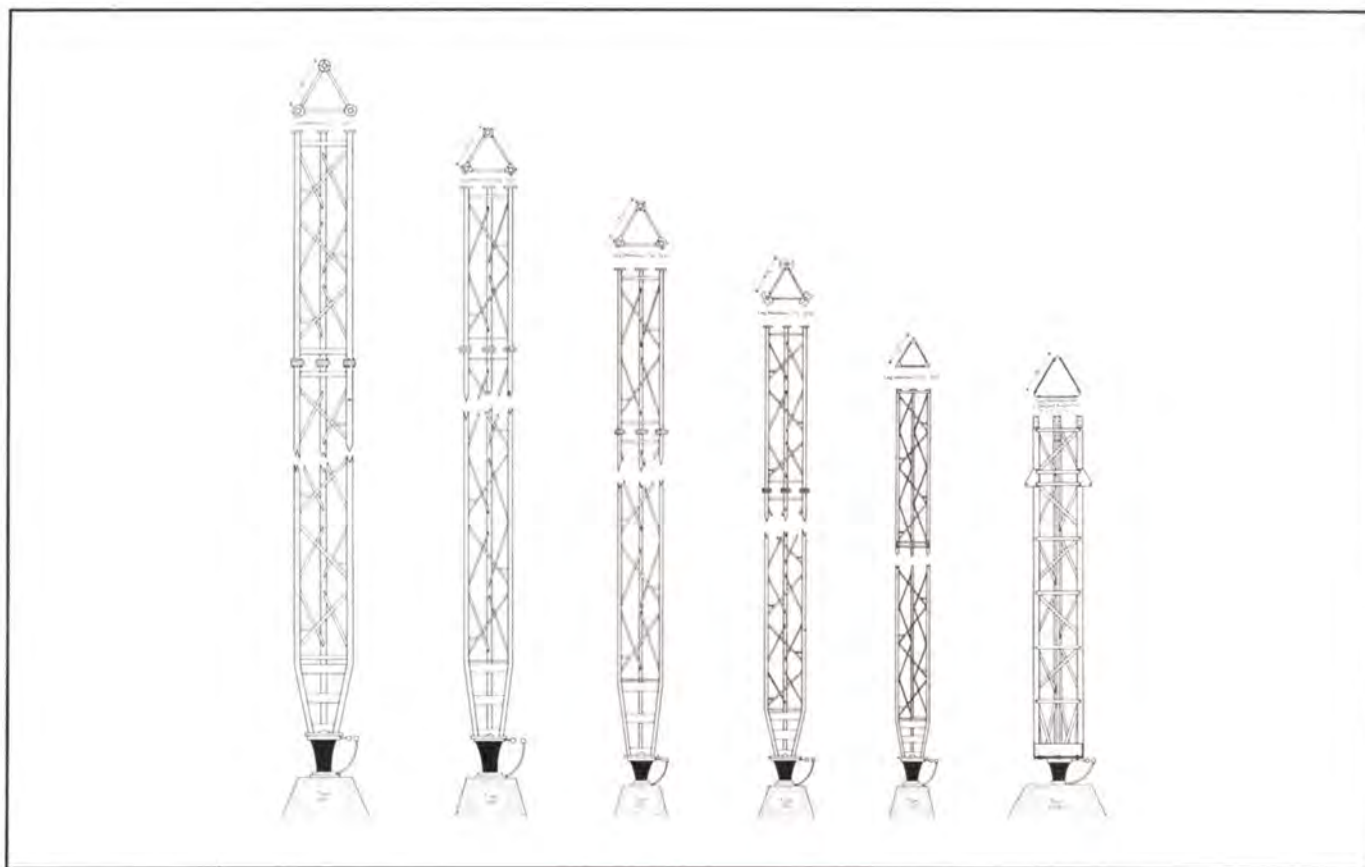

AM AND FM TOWERS

Collins furnishes a wide selection of both self-supporting and guyed antenna towers to meet the requirements of any AM or FM installation.

Towers are normally supplied with a protective coating of rust inhibitive paint prior to shipment, although they can be supplied with a galvanized finish at a slightly higher price. Galvanized is recommended in locations where the tower will be subjected to salt water spray, extreme humidity or other corrosive conditions. The finish coat is normally supplied by the tower erector and is in keeping with FAA requirement.

All hardware, fittings, guy insulators, anchor steel and base insulator (where required) are supplied with each tower. The applicable FCC (FAA) lighting kit and wiring are also provided.

UTILITY TOWERS

Available in six basic designs shown, Utility towers meet or exceed RETMA specifications. In the five standard models, steel pipe members are welded together in 20-foot sections, except for the top section length which is according to individual specification. The Type 170 KD tower is of bolted angle-iron construction in 10-foot sections.

Anchors are individually designed to meet the requirements of each tower installation. The I-beam used is imbedded in a concrete slab re-inforced with steel rods and with an earth fill on top.

Each section receives one coat of rust inhibitive, primer paint. Guy lines are galvanized and have a minimum breaking strength of at least twice the maximum calculated loads.

No Part Number

Tower Type	Maximum Recommended Height	Tower Width	Weight Per Foot*	Type of Base Insulation
480	480 ft. (146.3 m)	33 in. (83.82 cm)	28 lbs. (12.7 kg)	Locke or Lappe
340	350 ft. (106.68 m)	19 7/8 in. (50.48 cm)	17 lbs. (7.71 kg)	Utility 3401
220	250 ft. (76.2 m)	19 7/16 in. (49.37 cm)	12 1/2 lbs. (5.67 kg)	Utility 3401
180	200 ft. (60.96 m)	16 7/8 in. (41.12 cm)	10 lbs. (4.54 kg)	Utility 2201
120	200 ft. (60.96 m)	13 1/4 in. (33.34 cm)	8 lbs. (3.63 kg)	Utility 2201
170KD	320 ft. (97.54 m)	18 in. (45.72 cm)	17 lbs. (7.71 kg)	Utility 3401

*Tower steel only. Weight of guys, insulators, etc., not included.

FOOTAGE TABLE FOR BROADCAST TOWER HEIGHTS

550 KC TO 1070 KC					1080 KC TO 1600 KC				
KC	METERS	1 WAVE	1/2 WAVE	1/4 WAVE	KC	METERS	1-WAVE	1/2 WAVE	1/4 WAVE
550	545	1787.6	893.8	446.8	1080	277.8	911.1	455.5	227.7
560	536	1758.0	879.0	439.5	1090	275.2	902.6	451.3	225.6
570	526	1725.3	862.6	431.3	1100	272.7	894.4	447.2	223.6
580	517	1695.7	847.8	423.9	1110	270.3	886.5	443.2	221.6
590	509	1669.5	834.7	417.3	1120	267.9	879.0	439.5	219.7
600	500	1640.0	820.0	410.0	1130	265.5	870.8	435.4	217.7
610	492	1612.7	806.3	403.1	1140	263.2	862.6	431.3	215.6
620	484	1587.5	799.7	396.8	1150	260.9	855.7	427.8	213.9
630	476	1561.2	780.6	390.3	1160	258.6	847.8	423.9	211.9
640	469	1546.3	773.1	386.5	1170	256.4	840.9	420.4	210.2
650	462	1515.3	757.6	378.8	1180	254.2	834.7	417.3	208.6
660	455	1492.4	746.2	373.1	1190	252.1	826.8	413.4	206.7
670	448	1469.4	734.7	367.3	1200	250.0	820.0	410.0	205.0
680	441	1446.4	723.2	361.1	1210	247.9	813.1	406.5	203.2
690	435	1426.8	713.4	356.2	1220	245.9	806.3	403.1	201.5
700	429	1407.1	703.5	351.2	1230	243.9	799.1	399.5	199.7
710	423	1387.4	693.7	346.8	1240	241.9	793.7	396.8	198.4
720	417	1367.7	683.8	341.9	1250	240.0	787.2	393.6	196.8
730	411	1348.0	674.0	337.0	1260	238.1	780.9	390.4	195.2
740	405	1328.4	664.2	332.1	1270	236.2	774.7	387.3	193.6
750	400	1312.0	656.0	328.0	1280	234.4	768.8	384.4	192.2
760	395	1295.6	647.8	323.4	1290	232.6	762.9	381.4	190.7
770	390	1279.2	639.6	319.8	1300	230.8	757.0	378.5	189.2
780	385	1262.8	631.4	315.7	1310	229.0	751.1	375.5	187.7
790	380	1246.4	623.2	311.6	1320	227.3	746.2	373.1	186.5
800	375	1230.0	615.0	307.5	1330	225.6	739.9	369.9	184.9
810	370	1213.6	606.8	303.4	1340	223.9	734.7	367.3	183.6
820	366	1200.4	600.2	300.1	1350	222.2	728.8	364.4	182.2
830	361	1184.0	592.0	296.0	1360	220.6	723.2	361.1	180.5
840	357	1170.9	585.4	292.7	1370	219.0	718.3	359.1	179.5
850	353	1157.8	578.9	289.4	1380	217.4	713.4	356.2	178.1
860	349	1144.7	572.3	286.1	1390	215.8	707.8	353.1	176.5
870	345	1131.6	565.8	282.9	1400	214.3	703.5	351.2	175.6
880	341	1118.4	559.2	279.6	1410	212.8	696.9	348.4	174.2
890	337	1105.3	552.6	276.3	1420	211.3	693.7	346.8	173.4
900	333	1092.2	546.1	273.0	1430	209.8	688.1	344.0	172.0
910	330	1082.4	541.2	270.6	1440	208.3	683.8	341.9	170.9
920	326	1069.2	534.6	267.3	1450	206.9	678.6	339.3	169.6
930	323	1059.4	529.7	264.8	1460	205.5	674.0	337.0	168.5
940	319	1046.3	523.1	261.5	1470	204.1	669.4	334.7	167.3
950	316	1036.4	518.2	259.1	1480	202.7	664.2	332.1	166.5
960	313	1026.6	513.3	256.6	1490	201.3	660.2	330.1	165.0
970	309	1013.5	506.7	253.3	1500	200.0	656.0	328.0	164.0
980	306	1003.6	501.8	250.9	1510	198.7	651.7	325.8	162.9
990	303	993.8	496.9	248.4	1520	197.4	647.8	323.4	161.7
1000	300	984.0	492.0	246.0	1530	196.1	643.2	321.6	160.8
1010	297	974.1	487.5	243.7	1540	194.8	639.6	319.8	159.9
1020	294.1	964.6	482.3	241.1	1550	193.5	634.6	317.3	158.6
1030	291.3	955.3	477.6	238.8	1560	192.3	631.4	315.7	157.8
1040	288.5	946.2	473.1	236.5	1570	191.1	626.8	313.4	156.7
1050	285.7	937.1	468.5	234.2	1580	189.9	623.2	311.6	155.8
1060	283.0	928.2	464.1	232.0	1590	188.7	618.9	309.4	154.7
1070	280.4	919.7	459.8	229.9	1600	187.5	615.0	307.5	153.7

WIND VELOCITIES AND CORRESPONDING PRESSURES

TRUE "EXTREME" VELOCITY MILES PER HOUR	CYLINDRICAL SURFACES Pressure in Lbs./Sq. Ft. of Projected Area $P = 0.0025V_s^2$	FLAT SURFACES Pressure in Lbs./Sq. Ft. of Projected Area $P = 0.0042V_s^2$
10	.25	.42
15	.56	.95
20	1.00	1.7
25	1.6	2.6
30	2.3	3.8
35	3.1	5.2
40	4.0	6.7
45	5.1	8.5
50	6.3	10.5
55	7.6	12.7
60	9.0	15.1
65	10.6	17.8
70	12.3	20.6
75	14.1	23.6
80	16.0	26.9
85	18.1	30.4
90	20.3	34.0
95	22.6	37.9
100	25.0	42.0
105	27.6	46.3
110	30.3	50.8
115	33.1	55.5
120	36.0	60.5
125	39.1	65.6
130	42.3	70.9
135	45.6	76.5
140	49.0	82.3
145	52.6	88.3
150	56.3	94.5
155	60.1	100.9
160	64.0	107.5
165	68.1	114.3
170	72.3	121.4
175	76.6	128.6
180	81.0	136.1
185	85.6	143.7
190	90.3	151.6
195	95.1	159.7
200	100.0	168.0
205	105.1	176.5
210	110.3	185.2
215	115.6	194.1
220	121.0	203.3
225	126.0	212.6

HUGHEY & PHILLIPS RING TRANSFORMER



For use wherever 60 cps energy must be transferred across two points with very low capacitance or at very high voltages. Provides a highly reliable, low capacity means of supplying power across base insulator or insulated radio towers employed as radiators. Their relatively large spacing and low capacity between windings make these isolation transformers desirable for use in directional arrays, and especially with radiators which develop very high voltages across the base insulators. No tuning or RF adjustments are necessary. Available in load capacities of 1750 watts (Model TI 2017) and 3500 watts (Model TI 2035).

Part No. 097 6920 00 (Type TI 2017)
Part No. 099 0365 00 (Type TI 2035)

FISHER-PIERCE 63305-C BEACON LIGHT CONTROL



Designed to be mounted on either curved or flat surfaces, the 63305-C will automatically control broadcast tower, billboard or street lighting system directly or with auxiliary controllers. Operated by stable phototube with high sensitivity to north sky illumination, which is predictable and smooth in decline to darkness.

Power Requirements: 105-130 v, 50-60 cps.
Built-in Load Contactor: Single Pole, Single Throw and Single Break.
Load Rating: 3,000 watts normally closed. Closed at night.

Part No. 097 1698 00

COPPER GROUND WIRE

Bare #10 copper ground wire is used for ground radials. Wire attaches to mesh ground screen.

Weight: 31.8' per lb.

Part No. 421 1010 001

COPPER GROUND STRAP

This fine quality copper ground strap is available in two sizes: 2" x .032" (4.02' per lb.), and 4" x .032" (2.01' per lb.).

Part No. 097 1445 00 (2" strap)
Part No. 097 0811 00 (4" strap)

TRUSCON MESH GROUND SCREEN

Expanded copper mesh ground screen is for use beneath base of antenna tower to increase soil conductivity. Available in 8' x 24' sheets.

Part No. 013 0107 00

FOAM HELIAX

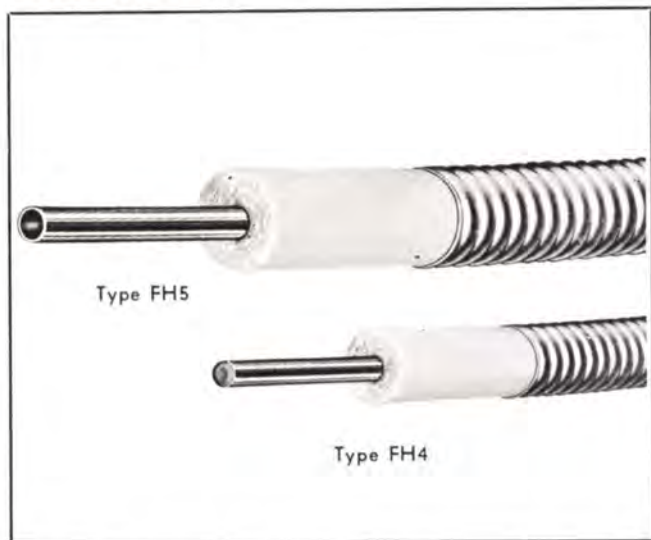

Foam HeliAx provides an economical low loss, high strength, corrosion resistant, long life, flexible connection between transmitter and antenna or other RF components.

The low density (approximately 0.45) and closed cell construction of the foamed insulation together with the high conductivity of both all-copper conductors results in minimum attenuation.

The corrugated outer conductor provides maximum resistance to crushing, kinking or denting.

The corrugated outer conductor also provides greater flexibility. Specifically, foam HeliAx can be formed to any given radius with approximately one-fourth the effort required to form cables with smooth wall aluminum outer conductors. The flexibility and kink resistance of foam HeliAx enable it to be pulled through conduits, around obstructions and through paths in which smooth wall tubing could not be installed.

CHARACTERISTICS

Nominal Size	1/2"	7/8"
Type No. Plain	FH4 (099 2454 00)	FH5 (099 1950—)
Type No. Jacketed	FHJ4 (099 2642 00)	FHJ5 (099 2625 00)

ELECTRICAL

Characteristic Impedance, Ohms	50	50
Velocity, per cent	79	79

MECHANICAL

Length	Cut to order	
Insulation	Foamed Polyethylene	
Major Diameter, Plain	0.540"	0.980"
Major Diameter, Jacketed	0.660"	1.000"
Inner Conductor, Diameter	0.158"	0.3125"

Average Bending Torque for Minimum Radius

Plain	5.7 ft./lbs.	14.0 ft./lbs.
Jacketed	7.7 ft./lbs.	20.0 ft./lbs.
Minimum Radius, Inches	5	10
Net Weight, Pounds per Foot		
Plain	0.19	0.35
Jacketed	0.24	0.42

PACKAGING INFORMATION

Type FH4, Part No. 099 2454 00, 1/2" foam HeliAx: Lengths up to 500 feet shipped in cardboard carton. Over 500 feet shipped on no deposit, no return reels.

Type FH5, Part No. 099 1950—, 7/8" foam HeliAx: Lengths up to 200 feet shipped in cardboard carton. Over 200 feet shipped on no deposit, no return reel.

CABLE FITTINGS



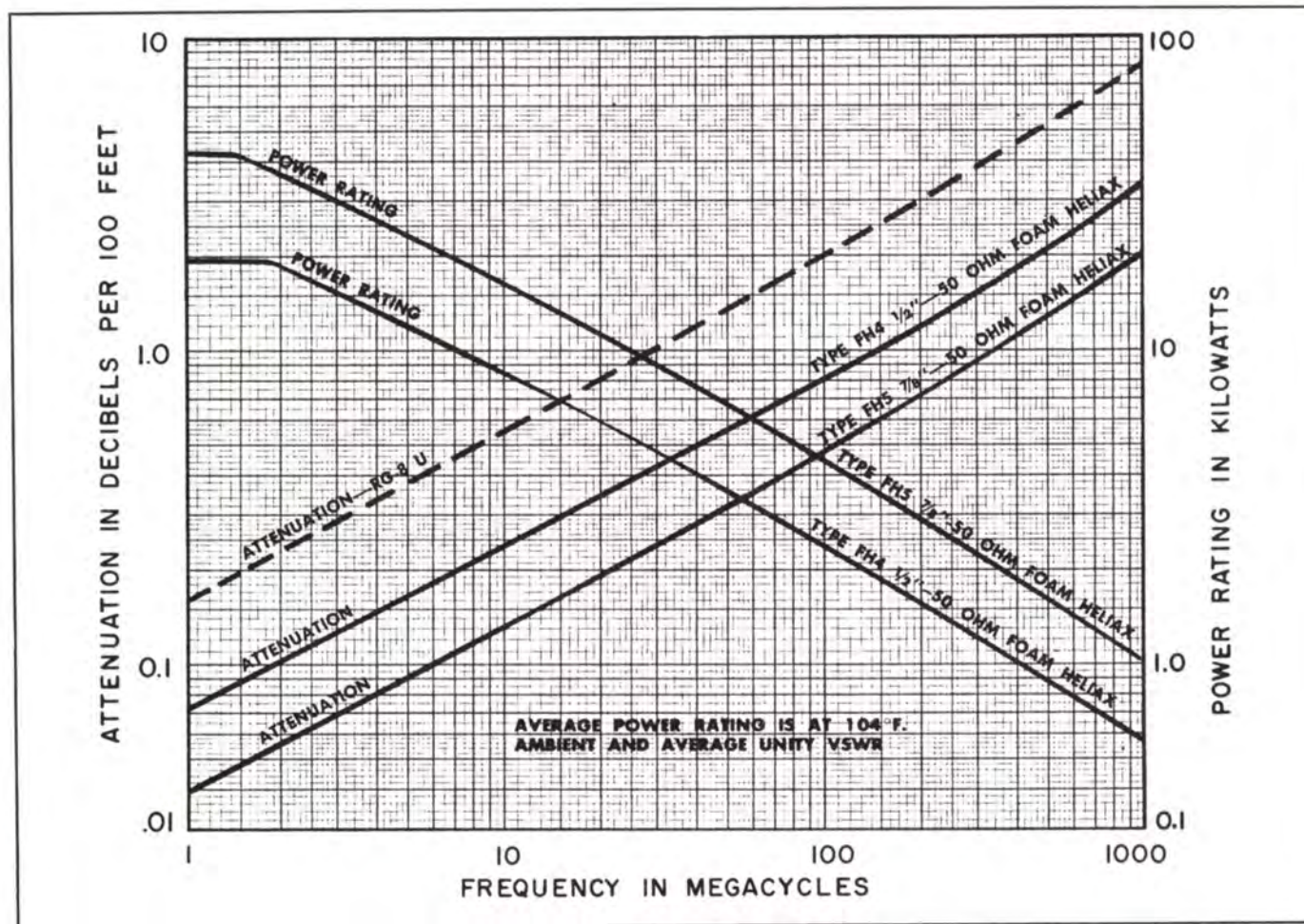

FLEXIBLE HELIAX COAXIAL CABLE

Helix is a low loss flexible cable produced in continuous splice-free lengths. Electrically and mechanically superior to rigid lines of comparable size, Helix is uniquely suited to modern communications systems. Helix cables are produced in 50, 75 and 100 ohms impedances with matching connectors. These connectors are easily attached with common hand tools and are fully compensated to assure excellent electrical performance.

TYPE H3-50

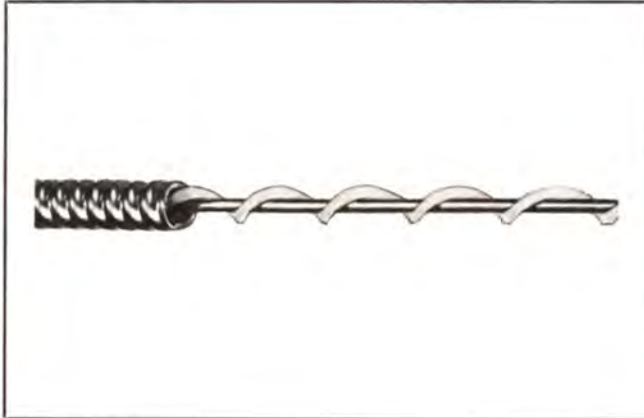

Type H3-50 Helix, Part No. 099 0008—, is a low loss highly flexible coaxial cable suited for VHF communica-

tions, aircraft and missile applications, low power signal measurements and RF instrumentation systems.

TYPE H5-50

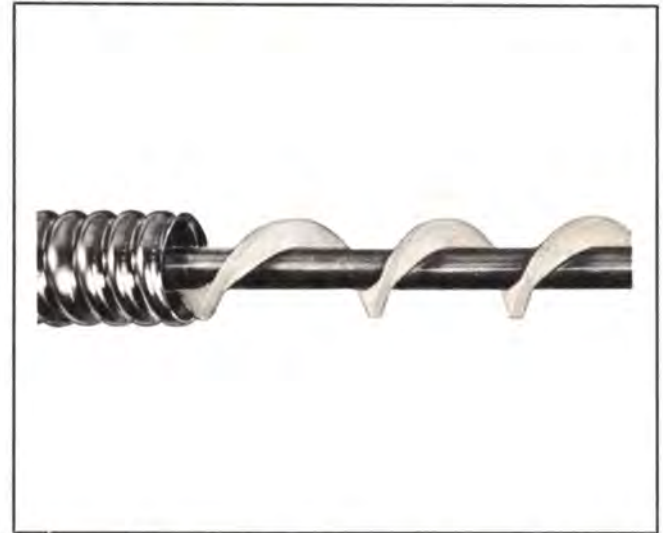

Andrew Type H5-50, Part No. 099 0204—, is the preferred RF cable for VHF/UHF communications. Produced in continuous splice-free lengths, the H5 series features inherently low SWR up to 3000 mc.

Also available are:

H5-75 (RG284/U) 75 ohm cable

H5-100 (RG285/U) 100 ohm cable

CHARACTERISTICS

SIZE	3/8"	7/8"	1 5/8"	3"
Type No. Plain	H3-50 099 0008—	H5-50 099 0204—	H7-50 099 0235—	H8-50A 099 2311—
RG Number, Plain	RG268/U	RG269/U	RG270/U	—
Type No., Jacketed	HJ3-50 099 2527 00	HJ5-50 099 1188—	HJ7-50 099 0890—	HJ8-50A 099 2312—
RG Number, Jacketed	—	RG318/U	RG319/U	—
ELECTRICAL				
Characteristic Impedance, ohms	50	50	50	50
Maximum Frequency, Mc	10800	5200	2800	1600
Velocity, per cent	89.5	91.6	92.1	93.3
Peak Power Rating, kw	10.0	44.0	145	315
MECHANICAL				
Insulation	POLYETHYLENE			
Copper Outer Conductor, Major Diameter, Inches	0.500	1.005	1.830	2.850
Jacketed Cable Outer Diameter, Inches	.620	1.125	2.000	3.020
Copper Inner Conductor, Major Diameter, Inches	0.162	0.358	0.688	1.140
Recommended Minimum Bending Radius, Inches	5	10	20	30
Net Weight, pounds per foot	0.200	0.444	1.000	1.200
Jacketed Cable, net weight, pounds per foot	0.250	0.520	1.313	1.700

JACKETED HELIAX

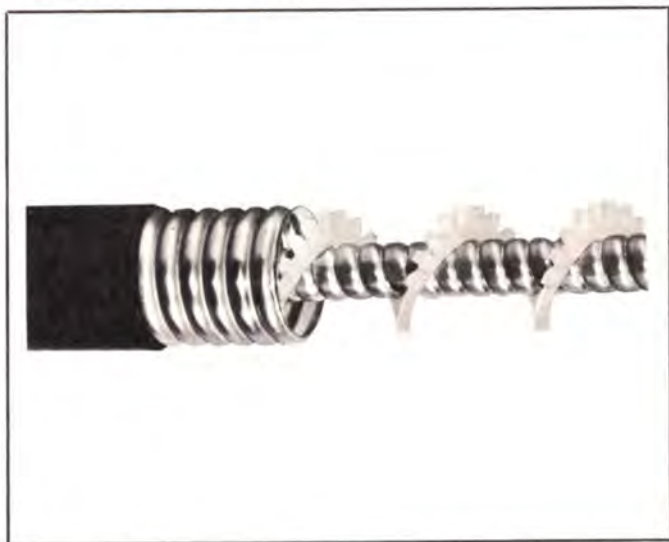

Because of the strength and corrosion resistance of the corrugated copper outer conductor, Heliac cables do not normally require jacketing. However, for direct burial in acid soil, very rough handling, or when the outer conductor must be insulated, jacketing is available. Both flooding compound and jacket thickness are closely controlled to provide a tough, abrasion resistant covering. Jacketing is recommended for extreme environments and direct burial.

HELIAX CONNECTORS

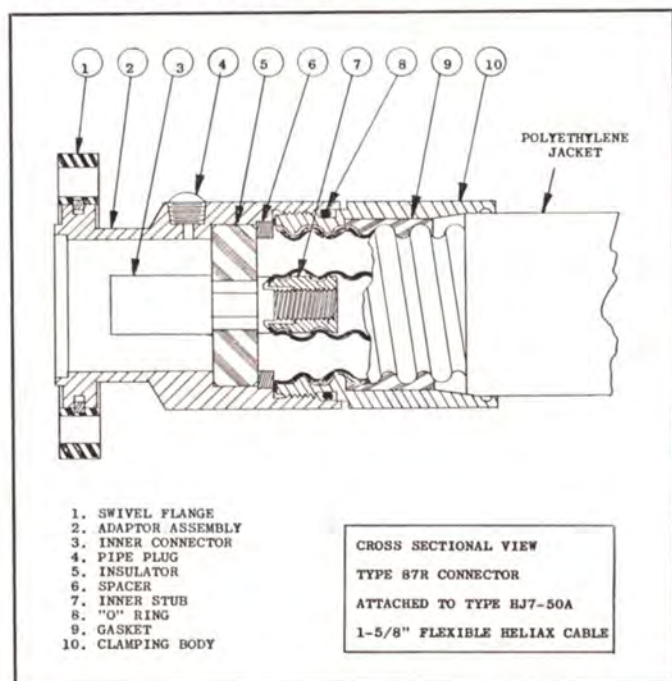

The cutaway view shows typical features common to most air dielectric Heliac connectors. These connectors feature Teflon anchor insulators for positive location of inner and outer conductors. There is no differential expansion problem in Heliac cables because of the contin-

uous self compensating corrugated construction. These connectors are used for both plain and jacketed cables.

TYPE H7-50



Type H7-50, Part No. 099 0235—, is the specified cable for FM and high frequency installations. Its very low attenuation and VSWR have made H7 popular at microwave frequencies.

Part No. 099 0235—

Also available:

Type H7-75 75 ohm cable

Type H7-100 100 ohm cable

TYPE H8-50A

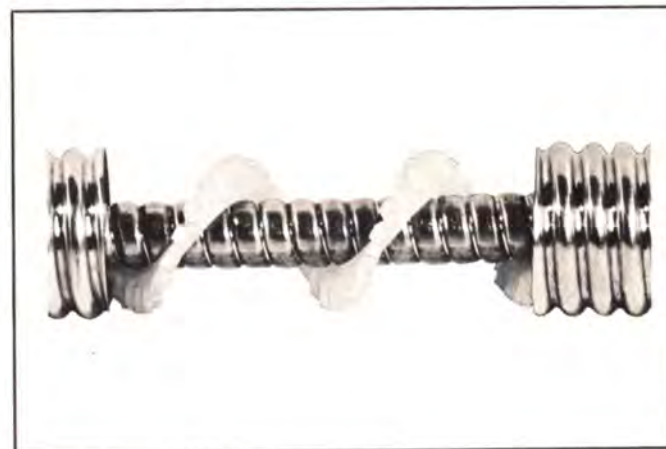

This nominal 3-inch low loss cable is extremely flexible and is available in continuous splice free, lengths to serve long and complex installations. End terminations of H8-50A cable mate with 3 1/8 inch EIA standard fittings.

Part No. 099 2311—

Also available: H8-75, 75 ohm cable

CABLE ASSEMBLIES

Although Heliac fittings are easily attached with common hand tools, factory attachment using production equipment is even more economical. We suggest that you order assemblies with fittings attached whenever possible.

ANDREW 50 OHM ACCESSORIES

EIA FLANGE



TYPE	SIZE	FOR TYPE
75AR (Part No. 099 0283 000)	7/8"	H5
87R* (Part No. 097 3002 00)	1 5/8"	H7
78R (Part No. 099 2314 000)	3"	H8

TYPE N JACK



TYPE	SIZE	FOR TYPE
73N (Part No. 099 0396 00)	3/8"	H3
75AN (Part No. 099 0400 000)	7/8"	H5
87N* (Part No. 099 3003 000)	1 5/8"	H7
78R (Part No. 099 2314 000) plus 2262 (Part No. 099 0445 00)	3"	H8

UHF JACK



TYPE	SIZE	FOR TYPE
73U (Part No. 099 0397 00)	3/8"	H3
75AU (Part No. 099 0401 000)	7/8"	H5
87U* (Part No. 099 3004 000)	1 5/8"	H7

* When ordering non-corrugated inner conductor, order older 77 series.

END TERMINAL

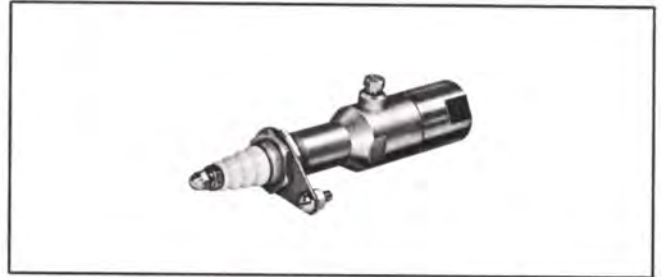

TYPE	SIZE	FOR TYPE
75AT (Part No. 099 0281 000)	7/8"	H5
87T* (Part No. 099 3005 000)	1 5/8"	H7
78R (Part No. 099 2314 000) plus 2062 (Part No. 099 0144 00)	3"	H8

REDUCER CONNECTOR



TYPE	SIZE	FROM TO
87S* (Part No. 099 3006 000)	1 5/8"	7/8" EIA
78S (NPN)	3"	1 5/8" EIA

MITER ELBOW



TYPE	FOR EIA FLANGE
1060 (Part No. 099 0404 000)	7/8"
1061 (Part No. 097 5620 000)	1 5/8"
1062 (Part No. 097 5621 00)	3 1/8"

ANDREW 50 OHM ACCESSORIES

GAS BARRIER



TYPE	FOR EIA FLANGE
1260A (Part No. 099 0203 000)	1 7/8"
1261B (Part No. 099 0238 000)	1 5/8"
1262A (Part No. 097 5754 00)	3 1/8"

EIA INNER CONNECTOR



TYPE	FOR SIZE	TYPE
18275 (Part No. 099 0406 000)	7/8"	H5
15069 (NPN)	1 5/8"	H7
15093 (NPN)	3"	H8

HOISTING KIT

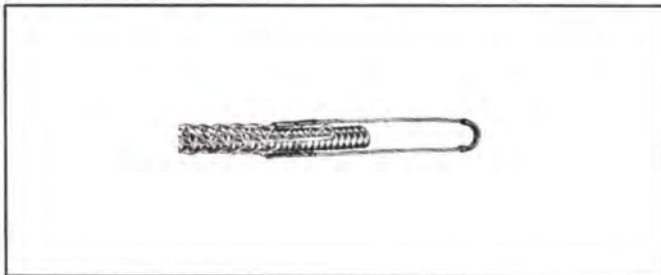

TYPE	FOR SIZE	TYPE
19256A (Part No. 099 0408 000)	7/8"	H5
24312 (Part No. 099 0420 00)	1 5/8"	H7
26985 (Part No. 099 2316 00)	3"	H8

INSULATED HANGERS



TYPE	FOR SIZE	TYPE
11662-2 (Part No. 099 0410 000)	7/8"	H5
24622 (Part No. 099 0124 00)	1 5/8"	H7
22418 (NPN)	3"	H8

MALE TO MALE ADAPTOR



Type No. 23187 (Part No. 097 7262 00) 3 1/8" EIA male to male adaptor.

OTHER ACCESSORIES

Type No. 12395-1
(Part No. 097 5010 000)
Wrap Lock

Type No. 24810
(Part No. 099 0109 000)
7/8" Ground Kit

Type No. 24811
(Part No. 099 0419 00)
1 5/8" Ground Kit

AVERAGE POWER RATINGS AND ATTENUATIONS FOR 50 OHM HELIAX CABLES

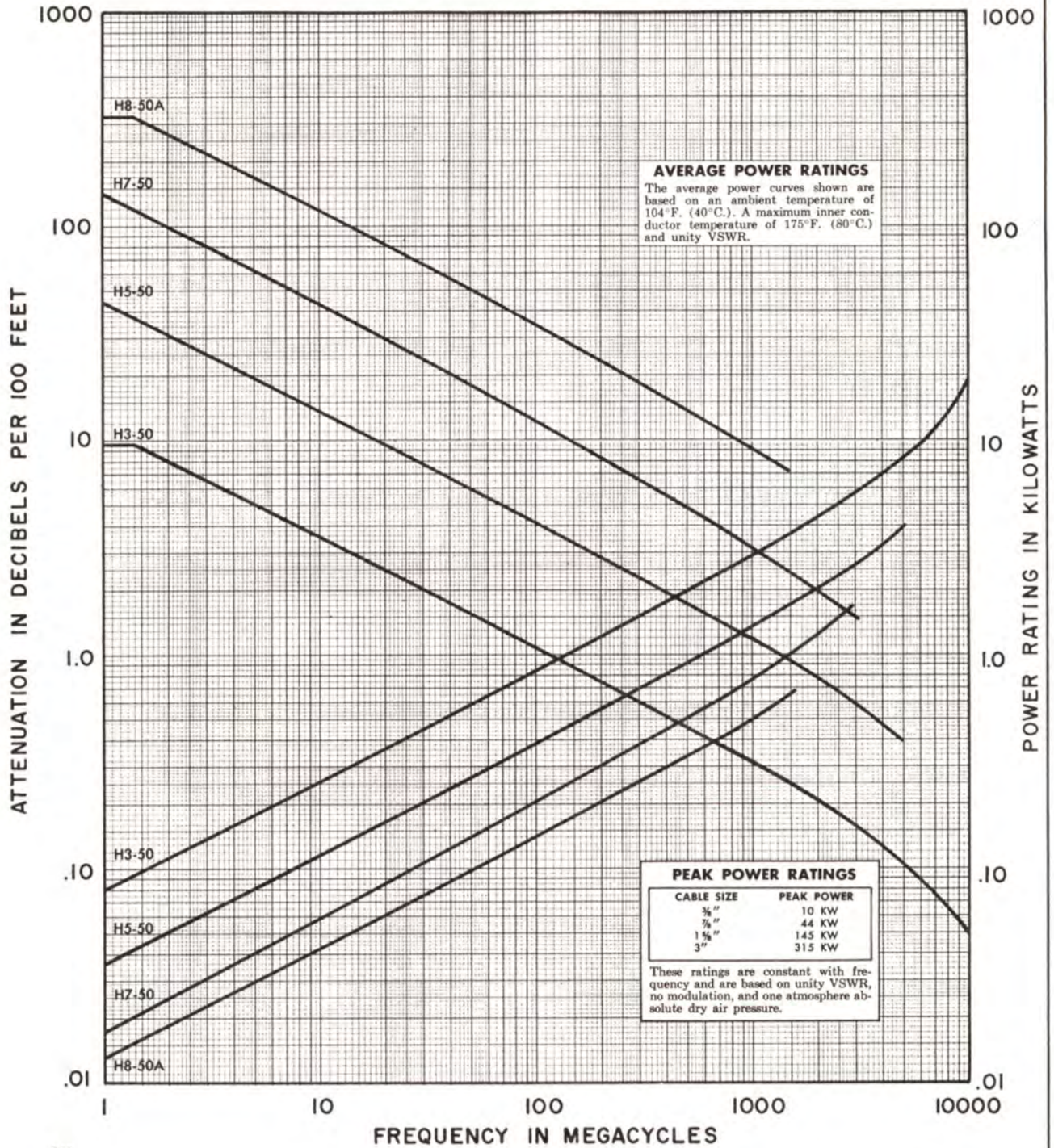

S18

EXTRA HIGH TEMPERATURE HELIAX

These low loss, high temperature air dielectric cables were developed for use in high ambient temperatures, such as in aircraft, missiles and space vehicles. Special dielectric materials were developed for low loss, high temperature properties. The flexible corrugated outer conductor uses silver clad materials that assure a high conducting level at maximum operating temperatures along with good mechanical properties.

Swivel flange fittings are available for both cables. These through type connectors incorporate metallic gas seals and anchor insulators as integral parts of the assemblies. A separate flanged gas barrier for Type 26445 cable is available.

Andrew's extensive development background is available to assist in your high temperature cable requirements. Andrew applications engineers are prepared to discuss your specific problem.

CHARACTERISTICS

Temperature Range	-100 to 825°C	-65 to 350°C
Size	3/8"	7/8"
Type Number	26459 (NPN)	26445 (NPN)
Characteristic Impedance, Ohms	50	50
Maximum Frequency, mc	5000	5000
Attenuation-db/100		
500 mc @ 25°C	2.6 db	.8 db
1000 mc @ 25°C	4.2 db	1.8 db
5000 mc @ 25°C	14.0 db	8.6 db
Attenuation-db/100		
500 mc @ 825°C	9.2 db	1.7 db
1000 mc @ 825°C	12.0 db	2.4 db
5000 mc @ 825°C	31.0 db	0.8 db
Velocity, per cent	89.5	90.8
Outer Conductor O.D. in.	.500	1.000
Recommended Minimum Bending Radius, inches	5	10

SOLID DIELECTRIC CABLES

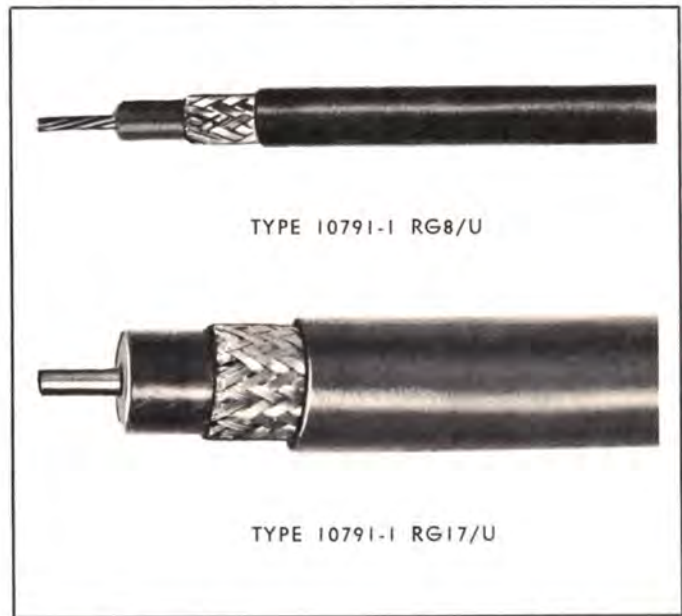

A wide variety of cables and fittings are stocked for prompt delivery. Cable assemblies and harnesses for interconnecting antennas and transmitters are in regular production. RG8/U, Part No. 099 0146—, and RG17/U, Part No. 099 0137—, cables have non-contaminating jackets for long useful life. Bulk quantities are shipped in cartons or disposable reels.

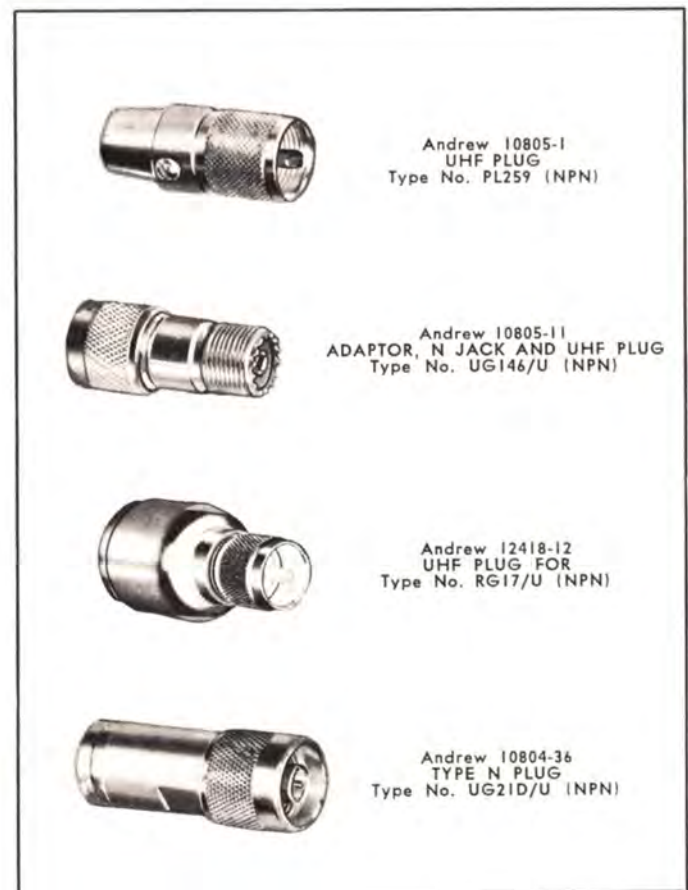

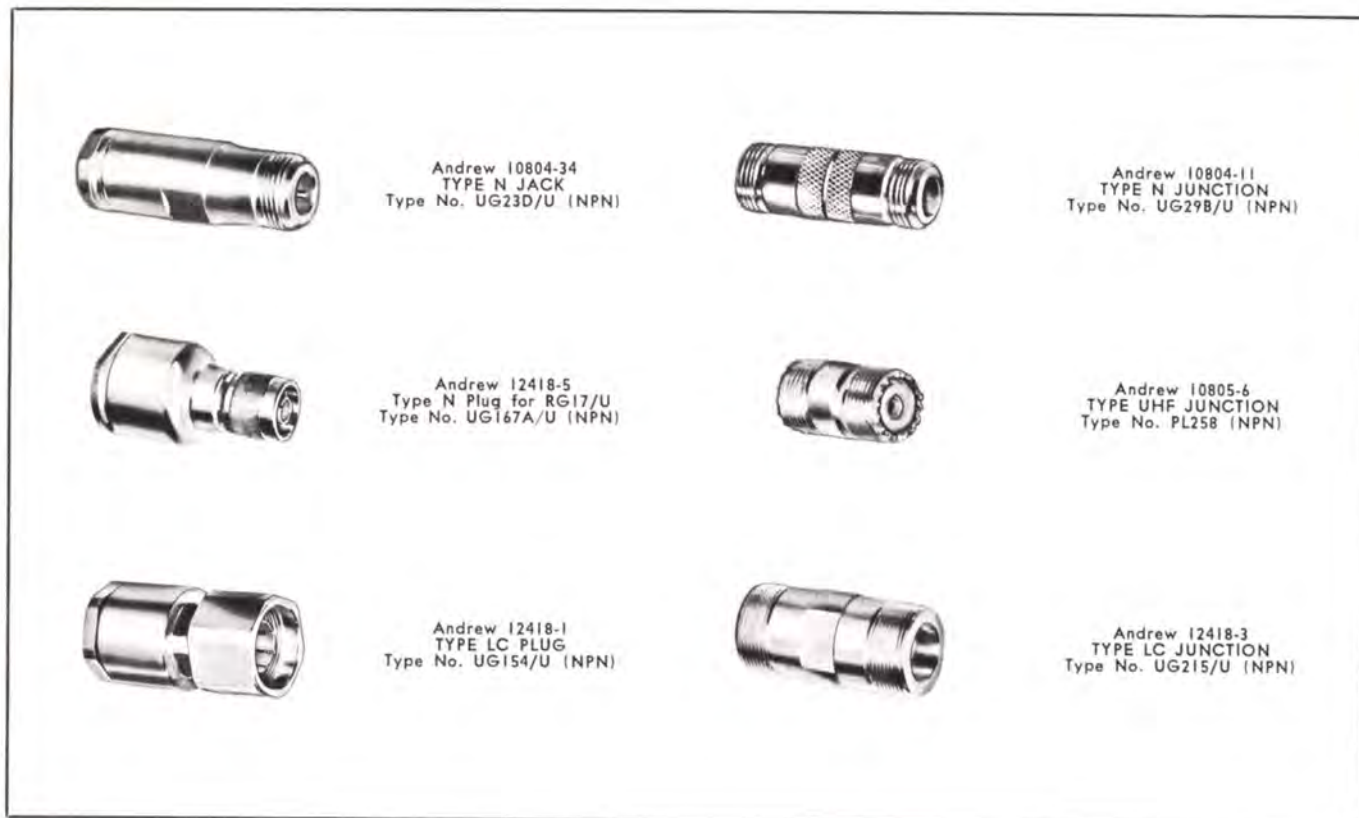

ANDREW RIGID TRANSMISSION LINES

Collins offers a complete selection of Andrew transmission lines and accessories matched for optimum system performance. All transmission lines and fittings are fully compatible with EIA standard RS-225. Equipments described are representative of current production designs.

Copper, the preferred choice for electrical and mechanical performance, is standard in all Andrew transmission lines. However, when weight is an important considera-

tion, chromate conversion coated aluminum lines and compatible fittings, are available.

Significant contributions have been made in the field of high peak power lines by Andrew engineers. Their high performance, critical designs receive special handling in manufacture to hold deviations to a minimum. A high voltage laboratory and stringent quality control assure maximum peak power service from every component in an Andrew system.

CHARACTERISTICS — ANDREW RIGID TRANSMISSION LINES

Size	7/8"	1 5/8"	3 1/8"	6 1/8"	9"
Type No.	560	561	562A	573	586
Part No.	(NPN)	(099 7096 00)	(097 7283 00)	(NPN)	(NPN)
Electrical					
Characteristic Impedance, ohms	50	50	50	50	50
Frequency Range, Mc	0-3000	0-2700	0-1600	0-750	0-440
Velocity, Per Cent	99.8	99.8	99.8	99.8	99.8
Peak Power Rating, kw	43	110	400	1500	3000
Average Power Rating					
Mechanical					
Outer Conductor, O.D. Inches	0.875	1.625"	3.125	6.125	9.000
Inner Conductor, O.D. Inches	0.341	0.664	1.315	2.6000	3.820
Net Weight, lbs.	13	25	55	135	310
No. of sections in crate	12	6	4	1	1
Shipping Weight, lbs.	400	290	425	305	340
Shipping Dimensions, in.	14x13x245	12x8x245	13x14x245	12x12x245	14 dia.x245

TYPE 562A 3 1/8" TEFLON INSULATED TRANSMISSION LINE

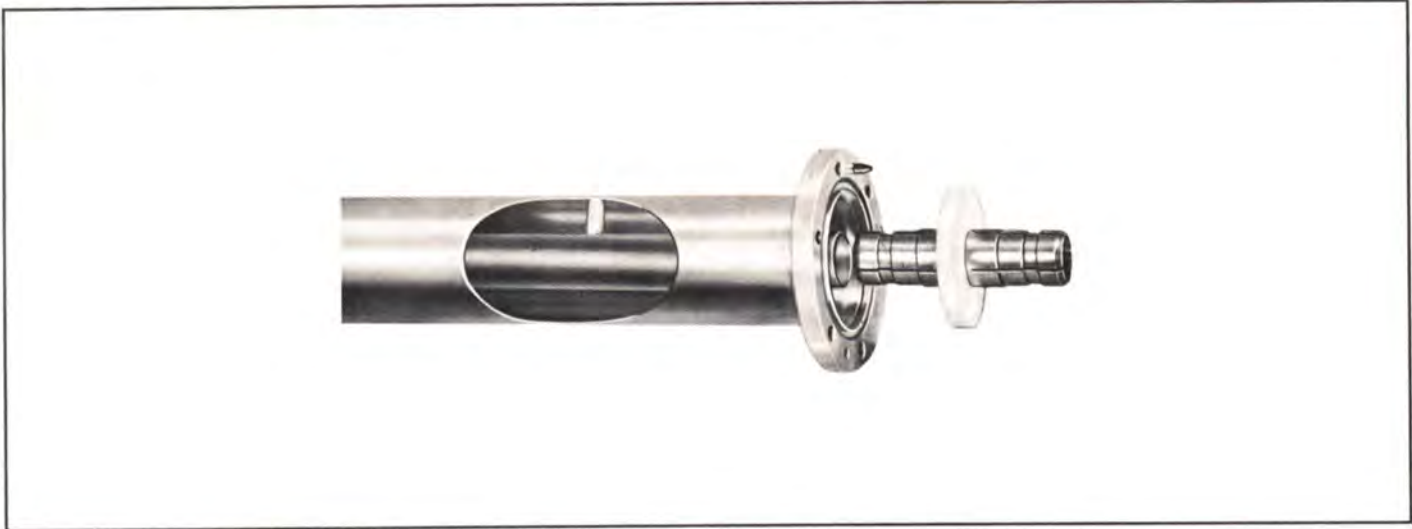

ANDREW 50 OHM ACCESSORIES — RIGID TRANSMISSION LINES

MITER ELBOW



TYPE	SIZE	FOR TYPE
1060 (Part No. 099 0404 000)	7/8"	560
1061 (Part No. 097 5620 000)	1 5/8"	561
1062 (Part No. 097 5621 00)	3 1/8"	562A
1073 (NPN)	6 1/8"	573
1086 (NPN)	9"	586

REDUCER



TYPE	FROM	TO
1860 (Part No. 097 5405 000)	560	561
1861 (NPN)	561	562A
1872 (NPN)	562A	573
18362 (NPN)	573	586

GAS BARRIER



TYPE	SIZE	FOR TYPE
1260A (Part No. 099 0203 000)	7/8"	560
1261B (Part No. 099 0238 000)	1 5/8"	561
1262A (Part No. 097 5754 00)	3 1/8"	562A
1273 (NPN)	6 1/8"	573
1286 (NPN)	9"	586

TYPE N ADAPTER



TYPE	SIZE	FOR TYPE
2260 (NPN)	7/8"	560
2261 (Part No. 097 7544 00)	1 5/8"	561
2262 (Part No. 099 0445 00)	3 1/8"	562A
1872 (NPN) plus 2262 (Part No. 099 0445 00)	6 1/8"	573

SPIR-O-LINE COAXIAL CABLE

Spir-O-line was designed and developed to replace sectional air or solid dielectric transmission line. Spir-O-line has been in production for more than five years, successfully performing in critical communication systems throughout the world. Spir-O-line possesses excellent broadband characteristics insuring reliable, trouble-free performance in AM, FM, VHF, UHF, television, microwave, radar, telemetering, missiles, rockets, data processing, patching circuits, delay lines, and many other applications.

Shipped on non-returnable reels.

FEATURES:

- Low Attenuation
- Fastest Installation
- Broadband
- Low V.S.W.R.
- No Periodicity
- Maximum Power Handling
- Minimum Maintenance
- No special installation tools required

Fabrication — The outer conductor is a commercially pure aluminum sheath. In addition to the natural strength of the sheath, additional crush resistance is obtained

through the support of the six polyethylene tubes which are in tangential contact with the high conductivity copper inner conductor. The intimate positioning of the cable's components ensures accurate centering of the inner conductor regardless of the length of cable.

Through the intimate positioning of the high density polyethylene tubes the individual air cells in the dielectric are further compressed such that they eliminate a direct air path between the inner and outer conductor. This design feature increases the breakdown voltage of Spir-O-line coaxial cable and also reduces the attenuation, thereby enabling Spir-O-line to surpass stringent cable system requirements.

Spir-O-line *eliminates* "Helical off-centering" and "slippage" of the inner conductor and cable core in vertical runs and is the only cable so designed.

Bending Radii are shown in table Pg. 49; however, more intricate bending is possible with tooling.

Spir-O-line is manufactured in various sizes and impedance for diversified applications, and is available in continuous lengths up to 1,000 feet or in shorter lengths as required.

Optional Jacket — The commercially pure aluminum sheath possesses excellent corrosion resistance; however, an optional polyethylene jacket is available for direct burial, corrosive atmospheres, or submarine applications.

DESCRIPTION

PART NO.	TYPE NO.	NOMINAL SIZE IN INCHES	OHMS	SPIR-O-LINE CABLE
099 0448—	259/U	3/8	50	Plain Aluminum Sheath
099 0451—	260/U	3/8	50	Polyethylene Jacketed
NPN		3/8	75	Plain Aluminum Sheath
NPN		3/8	75	Polyethylene Jacketed
099 0449—	252/U	1/2	50	Plain Aluminum Sheath
097 7023	253/U	1/2	50	Polyethylene Jacketed
NPN		1/2	75	Plain Aluminum Sheath
NPN		1/2	75	Polyethylene Jacketed
099 0450	255/U	7/8	50	Plain Aluminum Sheath
097 7527	254/U	7/8	50	Polyethylene Jacketed
NPN		7/8	75	Plain Aluminum Sheath
NPN		7/8	75	Polyethylene Jacketed
097 7078	257/U	1 1/8	50	Plain Aluminum Sheath
097 8131	258/U	1 1/8	50	Polyethylene Jacketed
NPN		1 1/8	75	Plain Aluminum Sheath
NPN		1 1/8	75	Polyethylene Jacketed

MECHANICAL AND ELECTRICAL PROPERTIES — SPIR-O-LINE

Characteristic Imped., Ohms	Nominal Size Inches	Effective Dielectric Constant	Velocity %	60 Cycle Peak Test Voltage KV	Outer Conductor		Inner Conductor		Polyethylene Jacket Wall	Minimum Radius Bending Inches	Shipping Length Feet	Maximum Pulling Tension Pounds	Net Weight per 1000 Ft. Pounds
					O.D.	I.D.	O.D.	Wall					
50	3/8	1.44	85.5	2.2	.390	.316	.115	Solid	.030	4	1000	210	100
	1/2	1.44	85.5	3.4	.530	.456	.165	Solid	.050	5	1000	270	175
	7/8	1.44	85.5	6.0	.953	.833	.311	Solid	.070	10	1000	770	555
	1 1/8	1.44	85.5	11.0	1.786	1.622	.606	.060	.070	25	1000	1850	1200
75	3/8	1.44	85.5	2.2	.390	.316	.071	Solid	.030	4	1000	210	100
	1/2	1.44	85.5	3.4	.530	.456	.104	Solid	.050	5	1000	270	175
	7/8	1.44	85.5	6.0	.953	.833	.191	Solid	.070	10	1000	770	555
	1 1/8	1.44	85.5	11.0	1.786	1.622	.372	.060	.070	25	1000	1850	1200

SHIPPING INFORMATION

Characteristic Imped.-Ohms	Nominal Size Inches	Reel Flange Dia.	Reel Drum Dia.	Reel Traverse	Tare Wt.-lbs.	Approx. Net Weight Pounds per 1000 ft.		Approx. Shipping Weight Pounds per 1000 ft.	
						Plain	Polyethylene Jacket	Plain	Polyethylene Jacket
50, 75	3/8	28"	20"	18"	35	100	140	135	175
	1/2	38"	32"	18"	45	175	225	220	270
	7/8	60"	48"	24"	100	555	655	655	755
	1 1/8	94"	80"	54"	1893	1200	1380	3093	3273

Spir-O-line cable, in lengths of 500 ft. and longer, is shipped on non-returnable reels* at no extra charge, thereby eliminating two-way freight charges and laborious records. Lengths less than 500 ft. are normally shipped in coils packed in cartons.
 *1 1/8" size Spir-O-line is shipped on a returnable reel.

SPIR-O-LINE HI-TEMP COAXIAL CABLE

High temperature Spir-O-line was specifically designed to accommodate ambient temperature applications of 180°C. This temperature is based on the maximum of 250°C. Spir-O-line Hi-Temp Cable is especially applicable in providing reliable service in rockets, missiles, aircraft, satellites and other high temperature coaxial requirements.

FEATURES:

- High Power
- Low Attenuation
- Fast Installation
- Minimum Maintenance
- Low VSWR
- Maximum Life
- No Radiation

Fabrication — Spir-O-line Hi-Temp is a modification of standard Spir-O-line Coaxial Cable. The high temperature cable is of the same design; however, two of the

cable's components were replaced with materials which were capable of retaining the same broadband, low loss characteristics of regular Spir-O-line, while now achieving the ability to withstand greater power and higher temperatures than standard Spir-O-line Coaxial Cable. These outstanding properties were obtained by manufacturing the supporting tubes from Teflon® instead of the usual Polyethylene. The high conductivity copper inner conductor was manufactured in tube-form rather than the usual copper rod, except for the 3/8" cable. The characteristics of the inner conductor were further improved by applying silver plating to the outer surface of the copper inner conductor. The light-weight aluminum sheath and the hollow inner conductor are very important in accommodating the weight requirements of the space age. Spir-O-line Hi-Temp is available in 100 ft. lengths and shorter.

DESCRIPTION

PART NO.	TYPE NO.	IN INCHES NOMINAL SIZE	OHMS	CABLE
NPN		3/8	50	Spir-O-line, Hi-Temp, Plain Aluminum sheath, Solid Inner Conductor
NPN		1/2	50	Spir-O-line, Hi-Temp, Plain Aluminum sheath, Tubular Inner Conductor
NPN	256/U	7/8	50	Spir-O-line, Hi-Temp, Plain Aluminum sheath, Tubular Inner Conductor
NPN		1 1/8	50	Spir-O-line, Hi-Temp, Plain Aluminum sheath, Tubular Inner Conductor

MECHANICAL AND ELECTRICAL PROPERTIES — SHIPPING INFORMATION

Characteristic Impedance Ohms	Nominal Size Inches	Effective Dielectric Constant	Velocity %	60 Cycle Peak Test Voltage KV	Outer Conductor		Inner Conductor		Minimum Bending Radius Inches	Shipping Length Feet	Maximum Pulling Tension Pounds	Net Weight per 100 Feet	Shipping Weight per 100 Feet
					O.D.	I.D.	O.D.	Wall					
50	3/8	1.44	85.0	2.2	.390	.316	.115	Solid	4	100	210	10 lbs.	27 lbs.
	1/2	1.44	85.0	3.4	.530	.456	.165	.020	5	100	270	17 lbs.	34 lbs.
	7/8	1.44	85.0	6.0	.953	.833	.311	.028	10	100	770	55 lbs.	77 lbs.
	1 5/8	1.44	85.0	11.0	1.786	1.622	.606	.060	25	100	1850	120 lbs.	220 lbs.

AVERAGE POWER RATINGS IN AIR AT 40°C. — SPIR-O-LINE

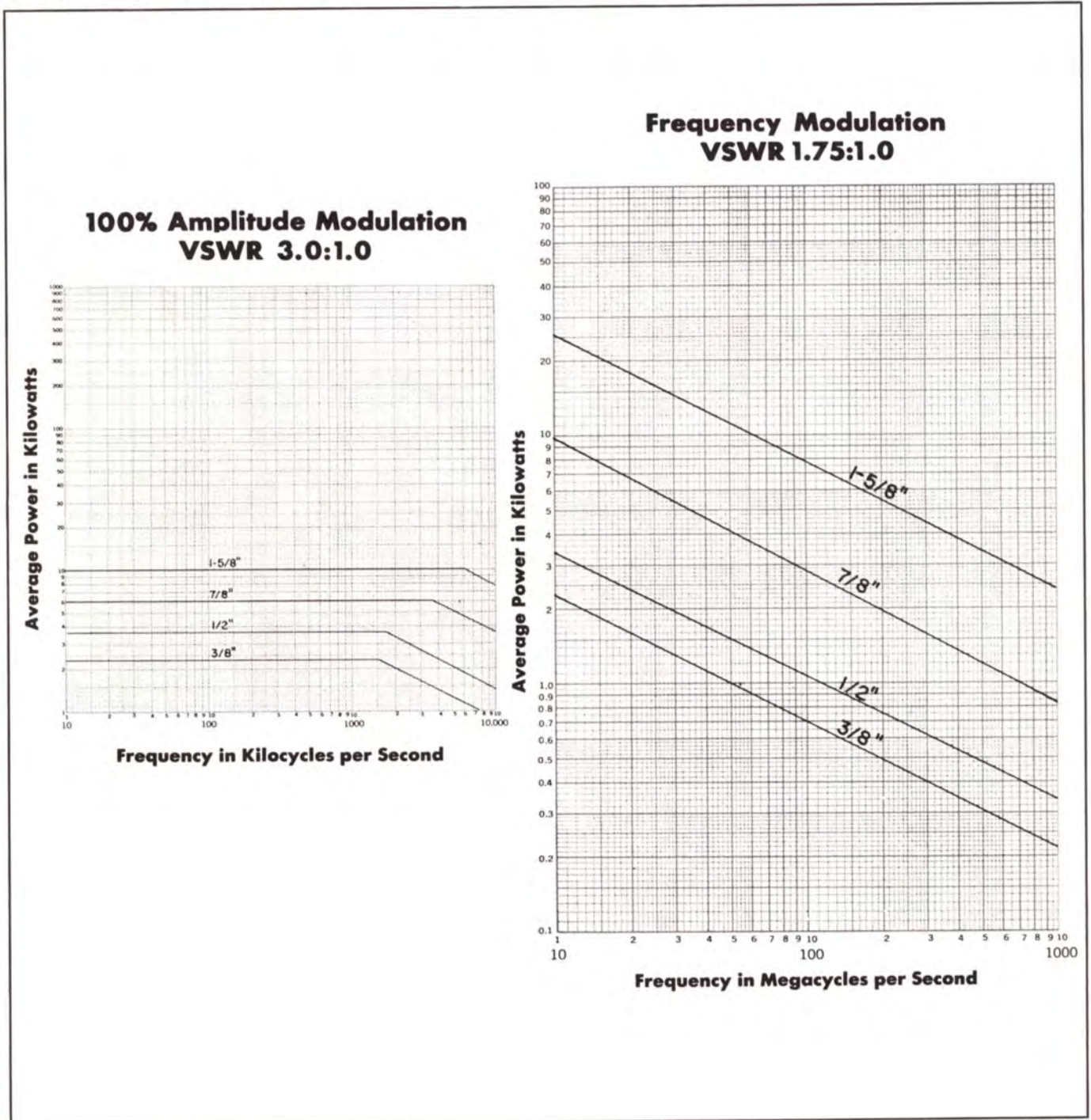

ATTENUATION VS. FREQUENCY (KILOCYCLES) — SPIR-O-LINE

50 OHM

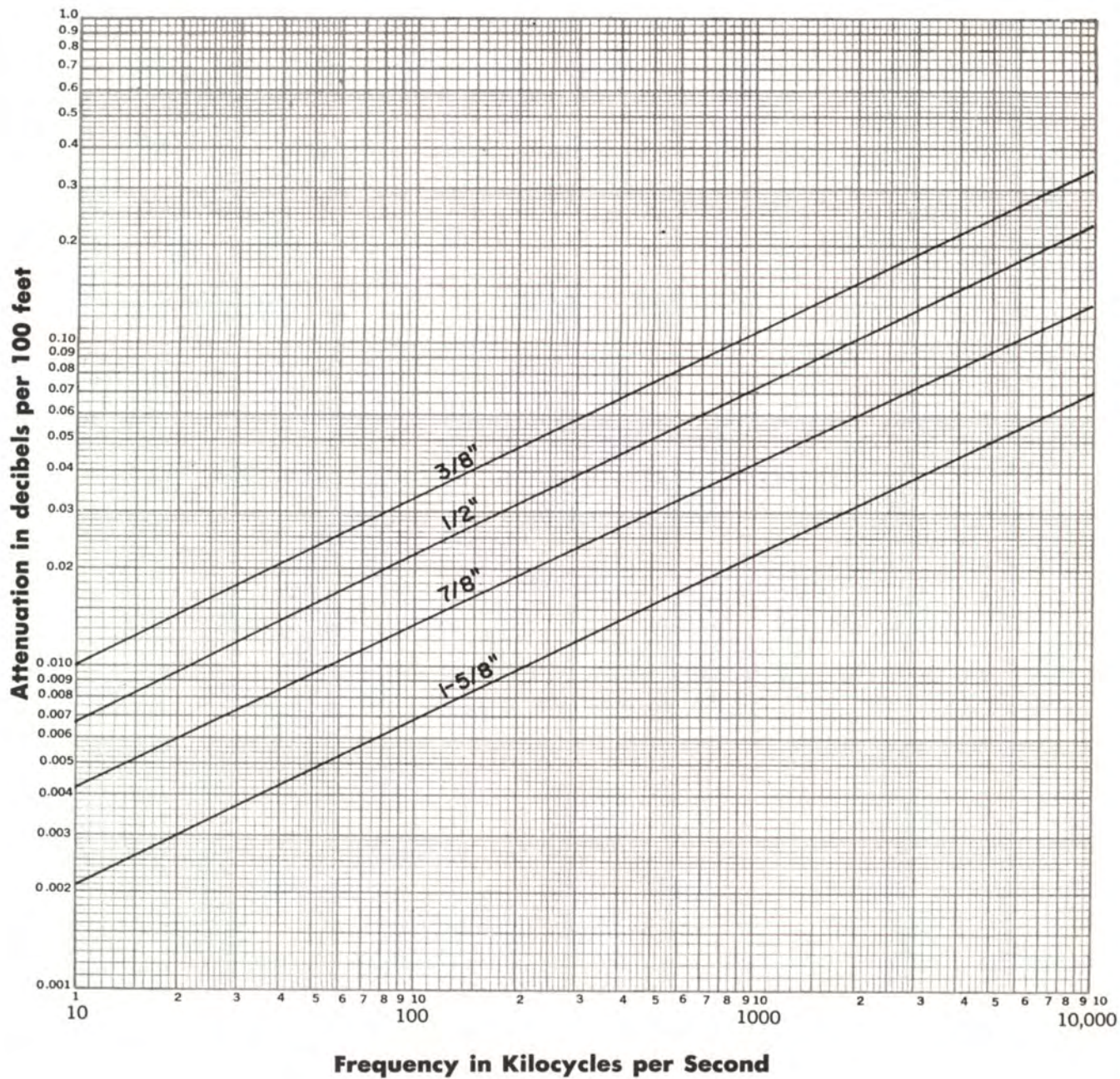

ATTENUATION VS. FREQUENCY (MEGACYCLES) — SPIR-O-LINE

50 OHM

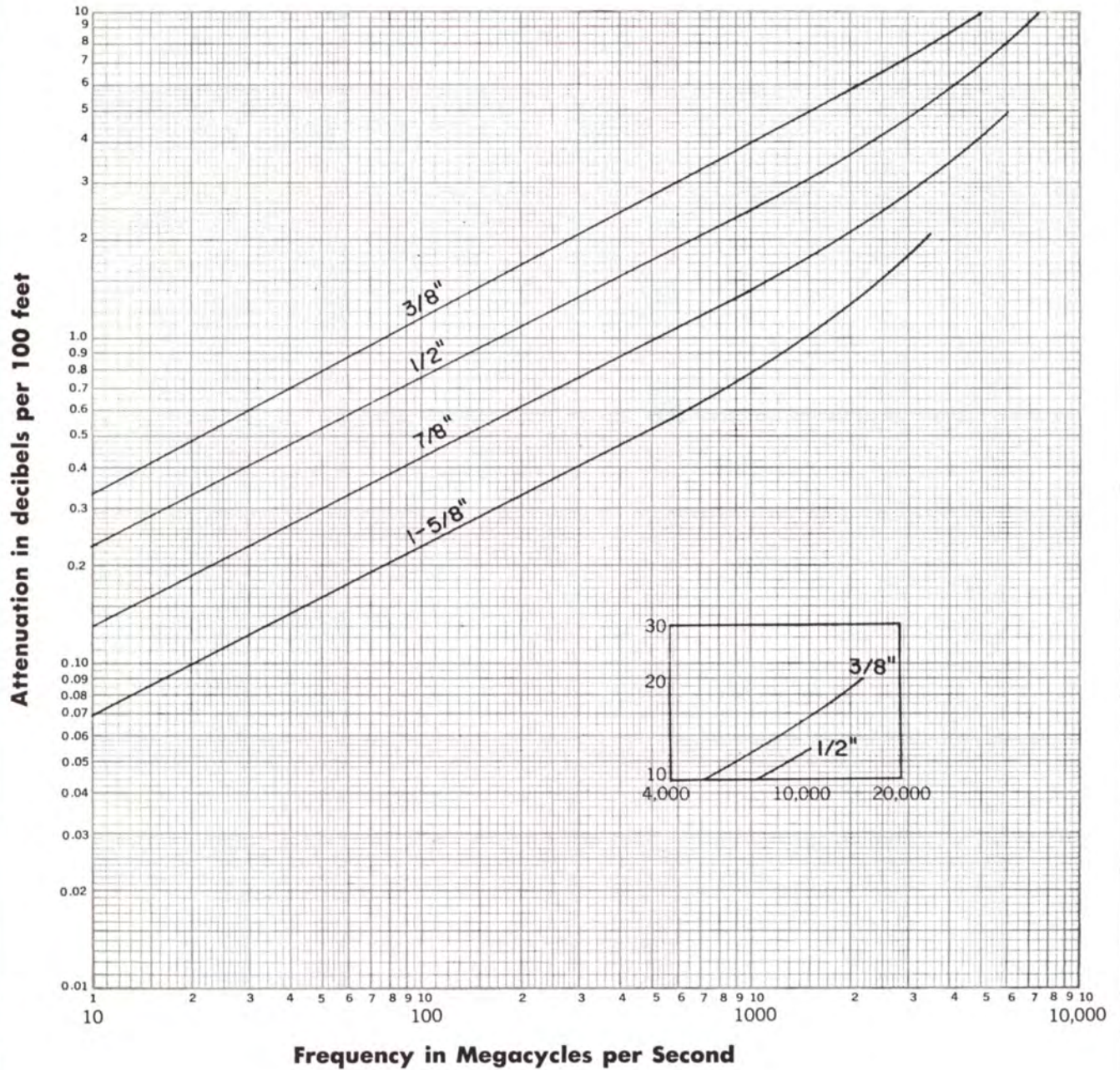

AVERAGE POWER RATINGS IN AIR AT 40°C. (KILOCYCLES) — SPIR-O-LINE

50 OHM

VSWR 1.1:1.0

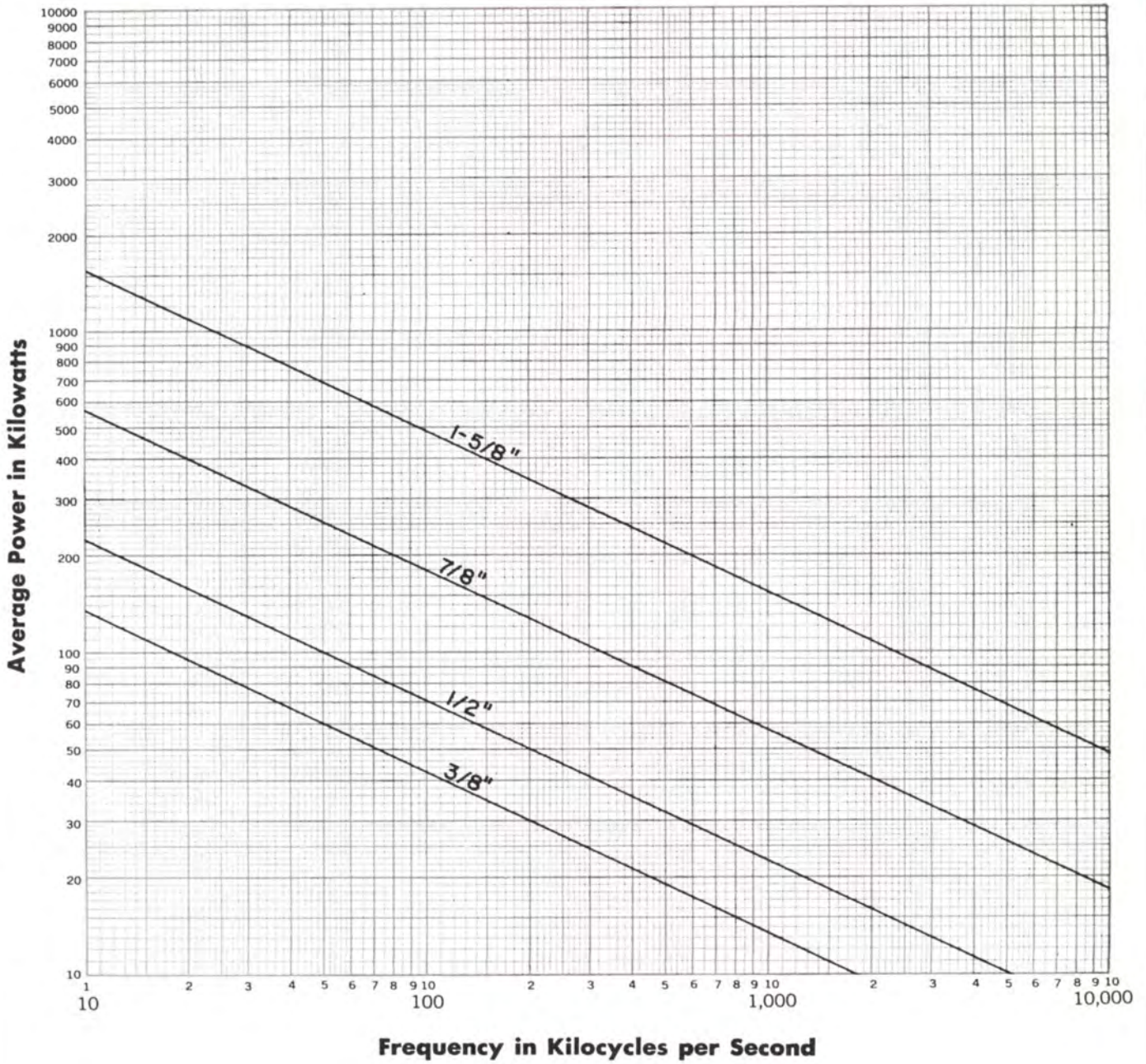

AVERAGE POWER RATINGS IN AIR AT 40°C. (MEGACYCLES) — SPIR-O-LINE

50 OHM

VSWR 1.1:1.0

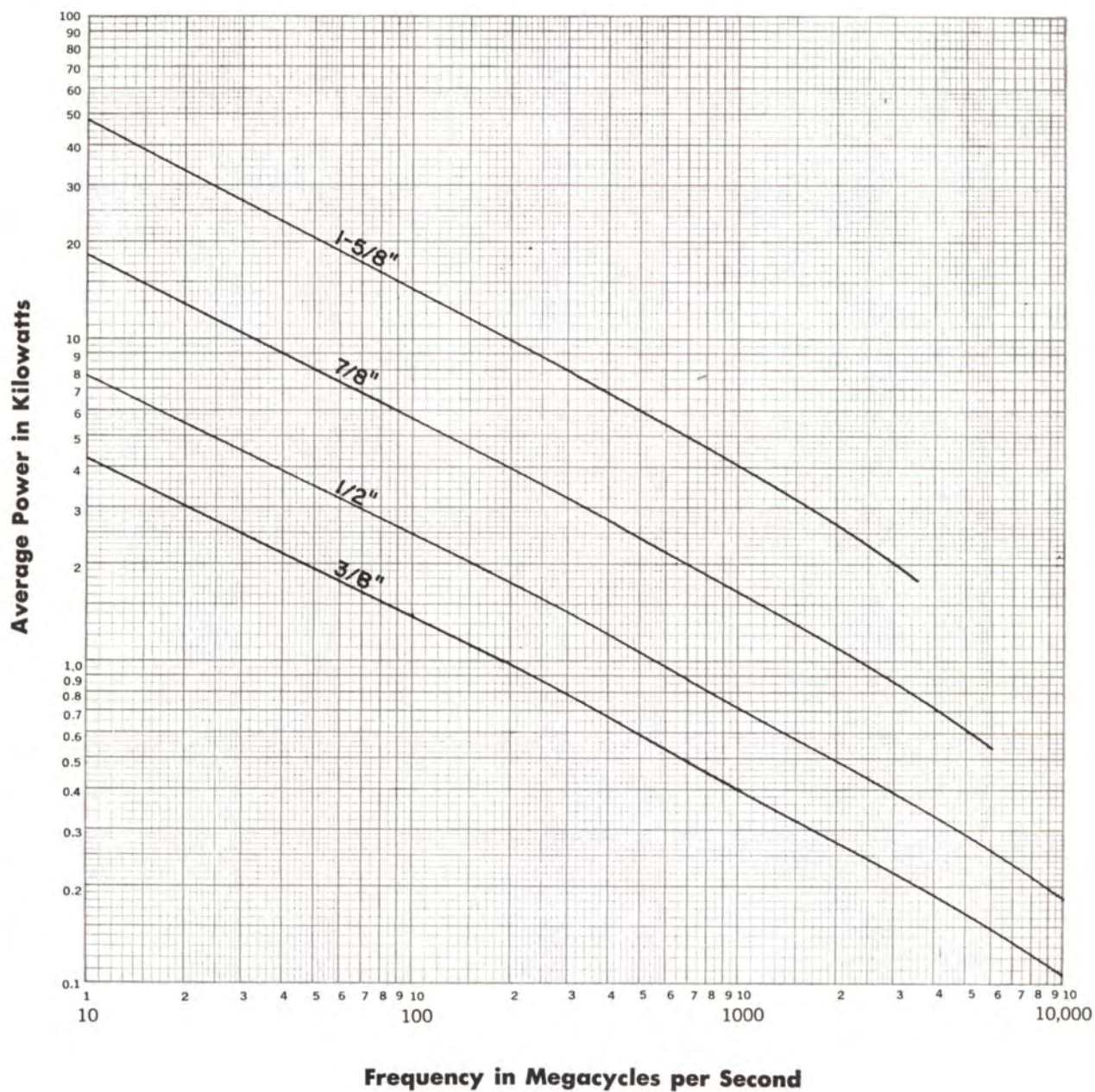

SPIR-O-LOK CONNECTORS

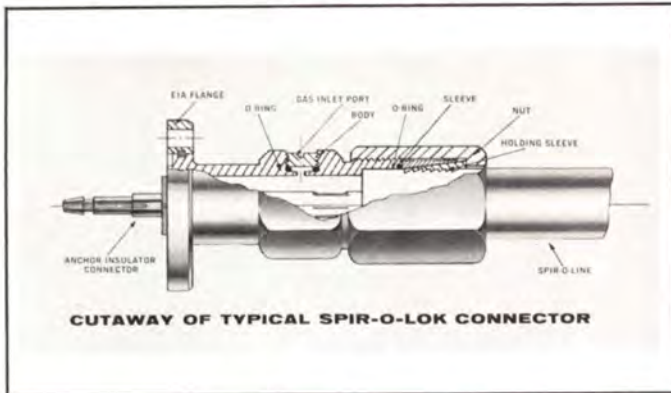

The Prodelin Spir-O-lok* Connector has been designed to facilitate the attachment of connectors to coaxial cable — eliminating special tooling and permitting rapid, trouble-free field assembly. The Spir-O-lok Connectors can be attached in minutes by inexperienced personnel with simple pocket tools. These connectors have been acclaimed the world over — achieving the fastest, simplest, and most positive air dielectric connection available. Regardless of the number of times the cable connection is assembled or dis-assembled, the Spir-O-lok Connector does not distort the cable sheath — mechanically or electrically.

All illustrated Spir-O-lok Connectors are available in a Hi-Temp version for use with Spir-O-line Hi-Temp coaxial cable. To order, merely add 1000 to the prefix of the desired connectors. For example:

75-500 — Standard Spir-O-lok Connector
 Becomes 1075-500 — Hi-Temp Spir-O-lok Connector.

FEATURES:

- No special application tools.
- Positive grip without distortion to cable sheath.
- Pressure-tight.
- Irridite finish for corrosion protection.
- Low VSWR.
- Connection can be made over and over again without replacing parts.
- Fastest connector to apply.

*U.S. Patent No. 3010747

50 OHM ADAPTERS

SPIR-O-LINE TO TYPE N FEMALE
 (CONNECTS TO UG-21/U)



Uncoupled Length is determined by adding 1/2" to the Coupled Length for each Spir-O-lok Nut to be uncoupled.

Type No.	Cable Size	Weight	Coupled Length Inches	Increases Cable Length Inches	Wrenches Required
75-375	3/8 in.	2 oz.	2 3/16	1 1/16	3/4 & 7/8
75-500	1/2 in.	2 oz.	2 7/8	1 1/16	7/8
75-875	7/8 in.	5.5 oz.	4 1 1/32	2 2 3/32	1 3/8
75-1625	1 1/8 in.	1 lb.	5 2 1/32	2 5/8	2

SPIR-O-LINE TO TYPE N MALE
 (CONNECTS TO UG-23/U)



Type No.	Cable Size	Weight	Coupled Length Inches	Increases Cable Length Inches	Wrenches Required
76-375	3/8 in.	2.5 oz.	2 3/4	1 1/32	3/4 & 7/8
76-500	1/2 in.	2.5 oz.	2 2 1/32	1 1/32	7/8
76-875	7/8 in.	6 oz.	4 1 1/32	2 5/16	1 3/8
76-1625	1 1/8 in.	1 lb.	5 1 1/32	2 3/4	2

SPIR-O-LINE TO TYPE LC MALE
 (CONNECTS TO UG-352/U)



Type No.	Cable Size	Weight	Coupled Length Inches	Increases Cable Length Inches	Wrenches Required
77-500	1/2 in.	7 oz.	4	2 2 3/32	7/8 & 1 1/4
77-875	7/8 in.	6 oz.	4 1 1/32	2 5/32	1 3/8
77-1625	1 1/8 in.	1 lb. 2 oz.	6 1/8	2 1 1/32	2

**SPIR-O-LINE TO TYPE LC FEMALE
(CONNECTS TO UG-154/U)**



Type No.	Cable Size	Weight	Coupled Length Inches	Increases Cable Length Inches	Wrenches Required
78-375	3/8 in.	3 oz.	3 3/4	2 5/8	3/4 & 1 1/4
78-500	1/2 in.	5 oz.	3 31/32	2 11/16	7/8 & 1 1/4
78-875	7/8 in.	9 oz.	4 11/16	3 1/8	1 3/8
78-1625	1 5/8 in.	1 lb. 2 oz.	6 1/32	3 1/32	2

SPIR-O-LINE TO PL-258 (CONNECTS TO PL-259)



Type No.	Cable Size	Weight	Coupled Length Inches	Increases Cable Length Inches	Wrenches Required
84-375	3/8 in.	2 1/2 oz.	3 11/32	2 2 5/32	3/4 & 7/8
84-500	1/2 in.	4 oz.	3 21/32	2 2 5/32	7/8
84-875	7/8 in.	7.5 oz.	5 1/2	3 7/8	1 3/8
84-1625	1 5/8 in.	1 lb.	6 3/4	3 2 3/32	2

SPIR-O-LINE TO TNC FEMALE



Type No.	Cable Size	Weight	Coupled Length Inches	Increases Cable Length Inches	Wrenches Required
112-375	3/8 in.	2.5 oz.	2 27/32	1 1 5/32	3/4 & 7/8
112-500	1/2 in.	3 oz.	3 23/64	1 4 3/64	7/8
112-875	7/8 in.	7 oz.	4 1/8	1 1/8	1 3/8

SPIR-O-LINE TO EIA



Type No. (Part No.)	Cable Size	Weight	Coupled Length Inches	Increases Cable Length Inches	Wrenches Required
81-875 (097 7529 00)	7/8 in. to 7/8 in. (EIA) Male	7.5 oz.	2 1/4	1 1/2	1 3/8
81-1625 (097 7079 00)	1 1/8 in. to 1 1/8 in. (EIA) Male	1 lb. 6 oz.	4 23/32	1 1/4	2
82-375 (NPN)	3/8 in. to 3/8 in. (EIA) Male	6.5 oz.	2 1/4	1 1/4	3/4 & 1 3/8
82-500 (099 0484 00)	1/2 in. to 3/8 in. (EIA) Male	7 oz.	2 11/32	1 1/4	7/8 & 1 3/8
82-875 (097 7528 00)	7/8 in. to 1 1/8 in. (EIA) Male	1 lb. 3 oz.	3 7/8	2 1/4	1 3/8 & 2
82-1625 (099 0485 00)	1 1/8 in. to 3 1/8 in. (EIA) Male	2 lb. 4 oz.	6 3/4	1 3/8	2
85-500 (099 0486 00)	1/2 in. to 7/8 in. (EIA) Female	9.5 oz.	4 1/2	3	3/4 & 1 3/8
85-875 (099 0487 00)	7/8 in. to 7/8 in. (EIA) Female	6.5 oz.	3 11/16	2 1/2	1 3/8
85-1625 (097 7080 00)	1 1/8 in. to 7/8 in. (EIA) Female	1 lb. 2 oz.	6 11/32	3	2
124-1625 (099 0488 00)	1 1/8 in. to 1 1/8 in. (EIA) Female	1 lb. 7.5 oz.	6 1/2	3 3/4	2
142-875 (NPN)	7/8 in. to 1 1/8 in. (EIA) Female	1 lb. 3 oz.	4 1/2	2 7/8	1 3/8 & 2

SPIR-O-LINE TO TYPE HN MALE



Type No.	Cable Size	Weight	Coupled Length Inches	Increases Cable Length Inches	Wrenches Required
103-375	3/8 in.	2.5 oz.	3	1 5/16	3/4 & 7/8
103-500	1/2 in.	2.5 oz.	3 1/8	1 7/8	7/8
103-875	7/8 in.	6 oz.	4 1 3/32	2 11/32	1 3/8
103-1625	1 5/8 in.	1 lb.	5 2 3/32	2 3/8	2

Uncoupled Length is determined by adding 1/2" to the Coupled Length for each Spir-O-lok Nut to be uncoupled.

SPIR-O-LINE TO GR-874 UNPRESSURIZED

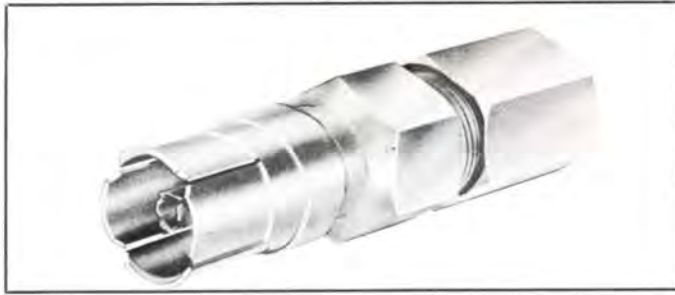

Type No.	Cable Size	Weight	Coupled Length Inches	Increases Cable Length Inches	Wrenches Required
122-375	3/8 in.	2 oz.	3 3/8	1 1/16	3/4
122-500	1/2 in.	2.5 oz.	3 9/16	1 1/16	7/8
122-875	7/8 in.	5 oz.	4 7/16	2 1/16	1 3/8

SPIR-O-LINE TO TYPE N MALE 90°
(CONNECTS TO UG-23/U)



Type No.	Cable Size	Weight	Coupled Length Inches	Increases Cable Length Inches	Wrenches Required
100-375	3/8 in.	3 oz.	2 5/16	5/16	3/4
100-500	1/2 in.	5 oz.	2 5/16	1 1/16	7/8
100-875	7/8 in.	6 oz.	3 1/16	1 3/4	1 3/8

SPIR-O-LINE TO TYPE N FEMALE 90°
(CONNECTS TO UG-21/U)



Type No.	Cable Size	Weight	Coupled Length Inches	Increases Cable Length Inches	Wrenches Required
101-375	3/8 in.	4.5 oz.	2 5/16	5/16	3/4
101-500	1/2 in.	4.5 oz.	2 5/16	1 1/16	7/8
101-875	7/8 in.	11.5 oz.	3 1/16	1 3/4	1 3/8

SPIR-O-LINE TO EIA MALE (90°)



Type No.	Cable Size	Weight	Coupled Length Inches	Increases Cable Length Inches	Wrenches Required
106-875	7/8 in.	9 oz.	4 3/8	2 1/16	1 3/8

SPIR-O-LINE TO TYPE HN MALE (90°)



Type No.	Cable Size	Weight	Coupled Length Inches	Increases Cable Length Inches	Wrenches Required
107-375	3/8 in.	3 oz.	2 3/16	1 1/16	3/4 & 7/8
107-500	1/2 in.	5 oz.	2 5/16	5/16	7/8
107-875	7/8 in.	6 oz.	3 1/16	1 3/4	1 3/8

50 OHM — COUPLINGS — REDUCERS

SPIR-O-LINE TO SPIR-O-LINE COUPLING



Type No. (Part No.)	Cable Size	Weight	Coupled Length Inches	Increases Cable Length Inches	Wrenches Required
79-375 (099 0489 00)	3/8 in.	2.5 oz.	3 3/4	1 1/2	3/4
79-500 (099 0490 00)	1/2 in.	3 oz.	3 15/16	1 1/2	7/8
79-875 (099 0116 00)	7/8 in.	7 oz.	5 1/4	2	1 3/8 & 1 1/4
79-1625 (099 0491 00)	1 1/8 in.	1 lb. 9 oz.	8 3/16	2	2

Uncoupled Length is determined by adding 1/2" to the Coupled Length for each Spir-O-lok Nut to be uncoupled.

SPIR-O-LINE TO SPIR-O-LINE REDUCER



Type No.	Cable Size	Weight	Coupled Length Inches	Increases Cable Length Inches	Wrenches Required
71-500	1/2 in. to 3/8 in.	3 oz.	3 ²⁷ / ₃₂	1 ⁵ / ₈	3/4 & 7/8
71-875	7/8 in. to 1/2 in.	5.5 oz.	4 ²⁷ / ₃₂	2	7/8 & 1 ³ / ₈
71-1625	1 ¹ / ₂ in. to 7/8 in.	2 oz.	6 ²⁷ / ₃₂	2 ¹ / ₄	1 ³ / ₈ & 2
72-1625	1 ¹ / ₂ in. to 1/2 in.	1 oz.	6 ⁵ / ₁₆	2 ¹ / ₈	7/8 & 2

50 OHM BULKHEAD AND END SEALS
SPIR-O-LINE TO SPIR-O-LINE BULKHEAD

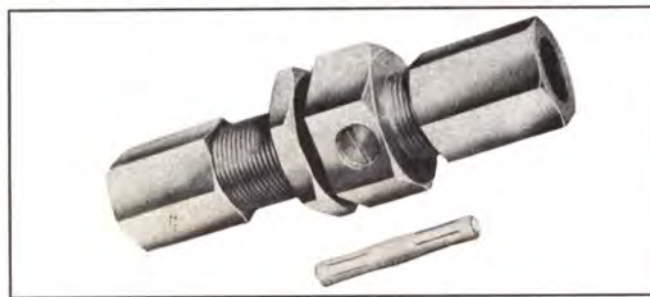

Type No.	Cable Size	Weight	Coupled Length Inches	Increases Cable Length Inches	Wrenches Required
80-375	3/8 in.	2.5 oz.	3 ¹⁵ / ₁₆	1 ¹ / ₂	3/4, 7/8 & 1 ¹ / ₈
80-500	1/2 in.	3 oz.	3 ¹⁵ / ₁₆	1 ¹ / ₂	7/8 & 1 ¹ / ₄
80-875	7/8 in.	8.5 oz.	5 ¹ / ₄	2	1 ³ / ₈ & 1 ³ / ₄
80-1625	1 ¹ / ₂ in.	1 lb 12 oz.	8 ¹ / ₁₆	2	2 & 2 ³ / ₄

SPIR-O-LINE TO TYPE N MALE BULKHEAD
 (CONNECTS TO UG-23/U)



Type No.	Cable Size	Weight	Coupled Length Inches	Increases Cable Length Inches	Wrenches Required
96-375	3/8 in.	3 oz.	2 ³ / ₄	1 ⁷ / ₃₂	3/4 & 1 ³ / ₈
96-500	1/2 in.	4 oz.	2 ¹³ / ₁₆	1 ¹³ / ₃₂	7/8 & 1 ³ / ₈
96-875	7/8 in.	9 oz.	4 ¹ / ₄	2 ⁷ / ₃₂	1 ³ / ₈ & 1 ³ / ₄
96-1625	1 ¹ / ₂ in.	16 oz.	6 ⁵ / ₁₆	2 ³ / ₄	2

SPIR-O-LINE TO TYPE N FEMALE BULKHEAD
 (CONNECTS TO UG-21/U)

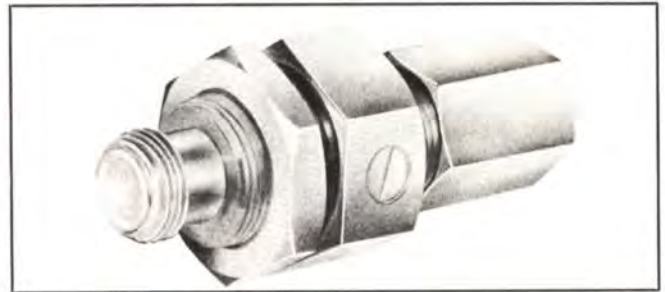

Type No.	Cable Size	Weight	Coupled Length Inches	Increases Cable Length Inches	Wrenches Required
97-375	3/8 in.	2.9 oz.	2 ⁵³ / ₆₄	1 ⁴ / ₄	3/4 & 1 ¹ / ₄
97-500	1/2 in.	3.5 oz.	2 ¹¹ / ₁₆	1 ⁴ / ₄	7/8 & 1 ³ / ₈
97-875	7/8 in.	8.8 oz.	4 ¹¹ / ₃₂	2 ² / ₃₂	1 ³ / ₈ & 1 ³ / ₄
97-1625	1 ¹ / ₂ in.	1 lb. 2 oz.	5 ²⁷ / ₃₂	2 ⁷ / ₈	2

SPIR-O-LINE TO TYPE HN FEMALE BULKHEAD

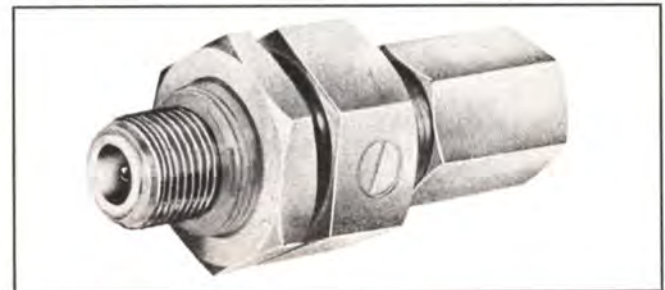

Type No.	Cable Size	Weight	Coupled Length Inches	Increases Cable Length Inches	Wrenches Required
109-375	3/8 in.	2.9 oz.	2 ⁵³ / ₆₄	1 ⁴ / ₄	3/4 & 1 ¹ / ₄
109-875	7/8 in.	8.9 oz.	4 ¹¹ / ₁₆	2 ⁷ / ₈	1 ³ / ₈ & 1 ³ / ₄

END SEALS



Type No. (Part No.)	Cable Size	Weight	Coupled Length Inches	Increases Cable Length Inches	Wrenches Required
95-375 (099 0492 00)	3/8 in.	3 oz.	6 ⁵ / ₈	5 ¹ / ₄	3/4
95-500 (099 0493 00)	1/2 in.	4 oz.	6 ¹ / ₄	5	7/8
95-875 (099 0494 00)	7/8 in.	8.5 oz.	7 ⁵ / ₈	6 ⁵ / ₁₆	1 ¹ / ₄ & 1 ³ / ₈
95-1625 (099 8132 00)	1 ¹ / ₂ in.	1 lb. 13 oz.	6 ⁷ / ₁₆	3 ⁷ / ₁₆	2

Uncoupled Length is determined by adding 1/2" to the Coupled Length for each Spir-O-lok Nut to be uncoupled.

POWER RATING COMPUTATIONS FOR SPIR-O-LINE AND SPIR-O-FOAM COAXIAL CABLES

POWER LIMITATIONS DUE TO VOLTAGE BREAKDOWN AND TEMPERATURE

To compute breakdown voltage using RF power when:

E = breakdown voltage in KV at sea level

S = Factor of safety

D = OD of the inner conductor in inches

C = Constant

50Ω Spir-o-line: C = 34

75Ω Spir-o-line: C = 46

50Ω Spir-o-line: Hi-Temp = C = 34

50Ω Spir-o-foam: C = 60

75Ω Spir-o-foam: C = 92

The formula is as follows: $E = \frac{CD}{S} \text{ KV}$

To determine the peak power based on voltage breakdown the following applies:

F = Constant

Pv = Peak power in KW based on voltage breakdown
 VSWR = Maximum Voltage Standing Wave Ratio anticipated. In AM service the value of Pv must be reduced by a factor of 4. There is also one additional limiting factor in coaxial cable. That, is maximum average power as limited by temperature rise, Pt.

$$P_t = \frac{\text{average power from page 54}}{(\text{SWR}) (\text{Duty Factor})}$$

Duty factor is applicable only in pulse applications. Pv and Pt must be computed to determine which is the limiting factor. The lowest value should be used as the maximum power handling capability of the transmission line.

$$P_v = \frac{FE, \text{ KW}}{(V\text{WSR})}$$

50Ω Spir-O-line F = 10

75Ω Spir-O-line F = 7

50Ω Spir-O-line Hi-Temp F = 10

50Ω Spir-O-foam F = 10

75Ω Spir-O-foam F = 7

EXAMPLES:

Problem: To find the maximum peak power of 7/8" 50Ω Spir-O-line, unpressurized at 60,000 ft. altitude, using a safety factor of 2 and a VSWR 2.0:1.0.

Solution: $E = \frac{34 (.311)}{2} = 5.31 \text{ KV}$

from the curve we note the cable will handle 6.5% of the Sea Level Voltage.

$E_{60,000} = .065 (5.31) = .345 \text{ KV}$

Peak power is

$$P_v = \frac{10 (.345)^2}{2} = 590 \text{ watts}$$

Problem: To find the maximum input power of 1/2" Spir-

O-Line Cable at 4 Kmc with a duty cycle of 0.01 and a VSWR of 2.0:1.

Solution: From curve on Page 54 at 4 Kmc the maximum average power (limited by temperature rise) is 330 W. The peak power by the above formula is:

$$P_T = \frac{\text{Average Power}}{(\text{SWR}) (\text{Duty factor})} = \frac{330}{2 \times 0.01} = 16.5 \text{ KW}$$

The peak power limited by temperature rise is 16.5 KW. The peak power limited by voltage breakdown is computed as follows:

$$E = \frac{34 (0.165)}{2} = 2.8 \text{ KV}$$

$$P_v = \frac{10 (2.8)^2}{2} = 39.2 \text{ KW}$$

The peak power limited by voltage breakdown is 39.2 KW.

Since the peak power due to temperature rise is lower, the maximum input power is 16.5 KW.

DETERMINATION OF OVERALL TRANSMISSION LINE EFFICIENCY

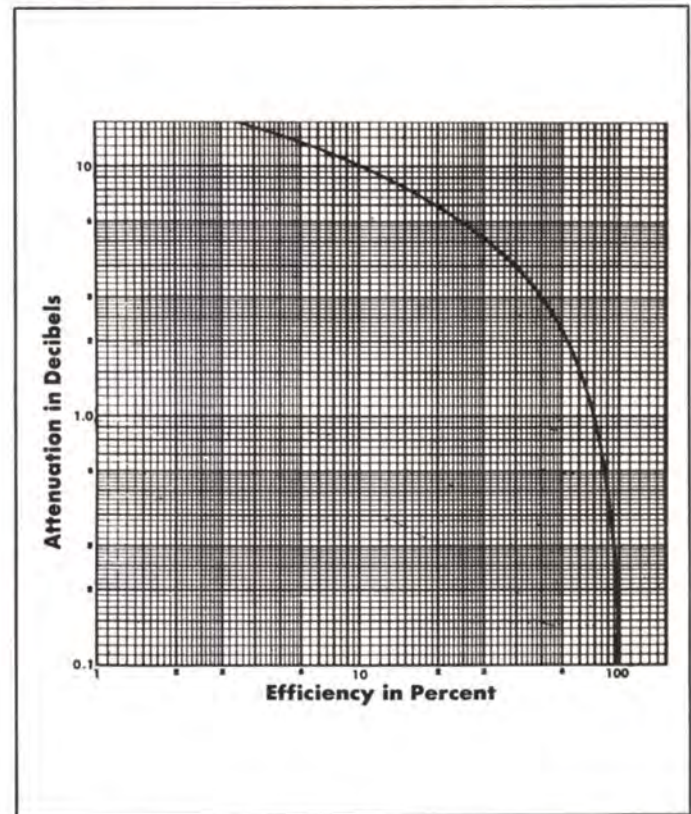

To obtain total loss in a given transmission line, multiply the attenuation in db per 100 ft. by the number of 100 foot lengths of line to be used. By referring to the curve on this page, the overall transmission efficiency may be determined.

ALTITUDE VS VARIATION IN PEAK VOLTAGES (for unpressurized cable)

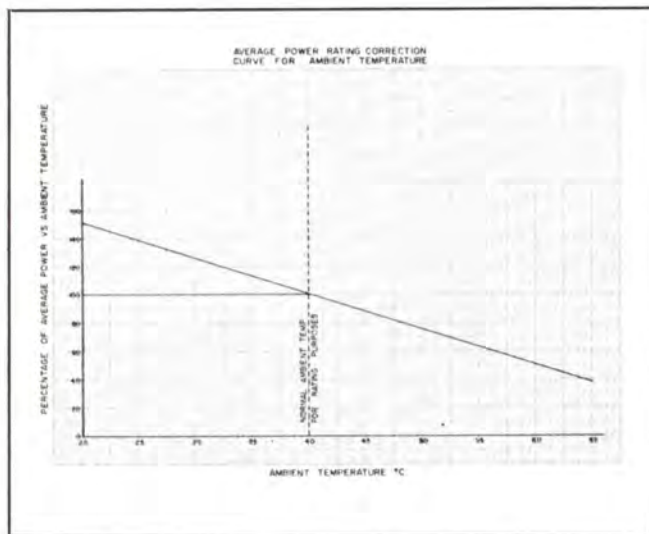
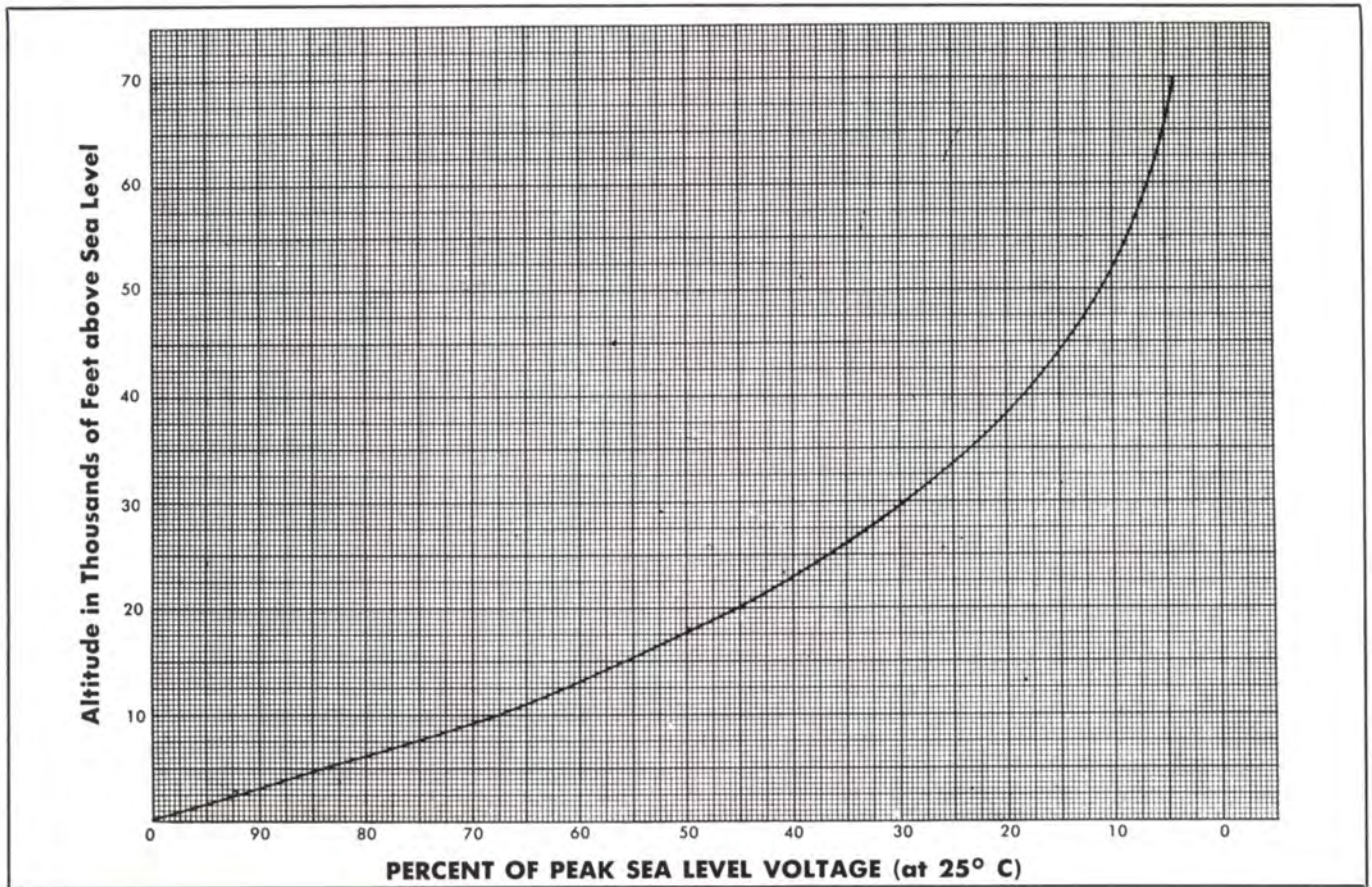

AVERAGE POWER RATING CORRECTION FOR AMBIENT TEMPERATURE—The maximum allowable temperature of the inner conductor of coaxial cable determines the average power rating. For Spir-O-line, using polyethylene dielectric, the maximum allowable temperature is 85°C. The temperature of the center conductor depends upon the power losses of the cable and the ambient temperature. The average power vs frequency curves shown for Spir-O-line and Spir-O-foam are based upon

an ambient temperature of 40°C and a temperature rise of 45°C. The power rating at ambient temperatures other than 40°C may be calculated by the above curve.

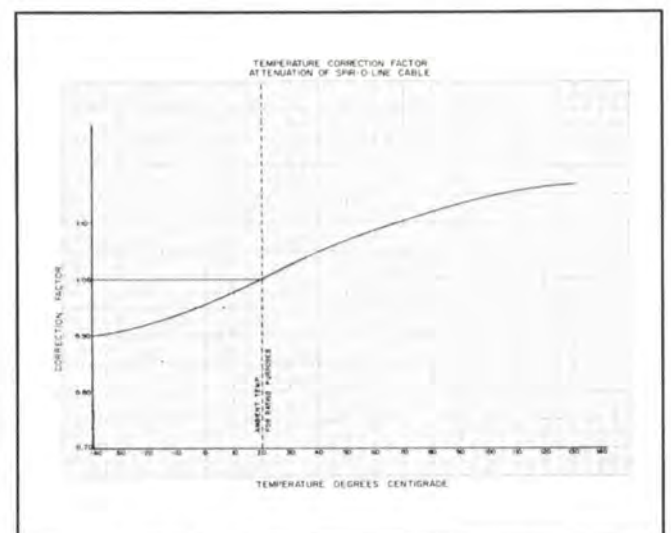

ATTENUATION CORRECTION FACTOR FOR TEMPERATURE—The attenuation vs frequency curves for Spir-O-line and Spir-O-foam are based upon an ambient temperature of 20°C. Attenuation at temperatures other than 20°C may be calculated by the above curve.

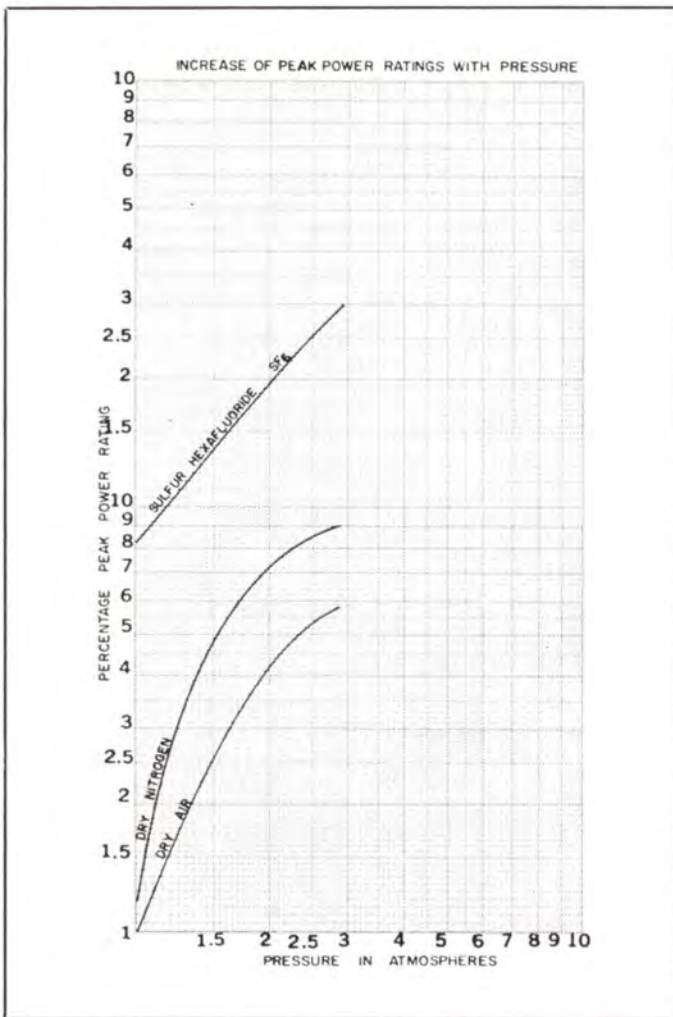

INCREASE OF PEAK POWER RATINGS WITH PRESSURE—The peak power ratings for Spir-O-line Cable can be increased by pressurization and/or the use of high dielectric strength gases. Curves showing the variation of peak power ratings vs pressure for dry air, sulfur hexafluoride (SF₆), and dry nitrogen (N₂) are shown in the above curve. Other gases may be used but their characteristics should be carefully investigated before using.

SPIR-O-LINE ACCESSORIES



Type No. 26-150 FLARE FITTING, 1/4" OD copper tube, 1/4" IPS male (includes flare nut). (NPN).



Type No. 27-150 FLARE FITTING, 1/4" OD copper tube, 1/8" IPS female (includes flare nut). (NPN).



Type No. 28-150 FLARE NUT, 1/4" OD copper tube size for use on flare fittings. (NPN).



Type No. 29-150 FLARE ELBOW, 1/4" OD copper tube, 1/8" IPS male (includes flare nut). (NPN).



Type No. 30-150 DEHYDRATOR, hand pump consists of blue indicating gel, and will pressurize up to 1000 ft. of 7/8" or 250 ft. of 1 5/8" Spir-O-line. (Part No. 099 0517 00).

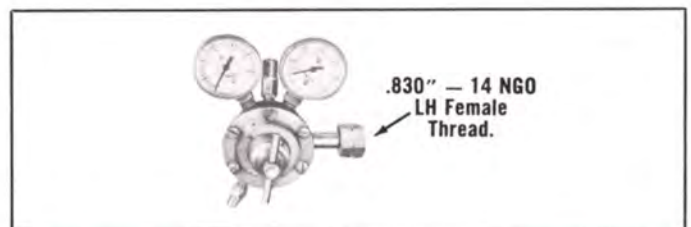

Type No. 31-150 PRESSURE REGULATOR, for use with cylinder Type No. 43-150. (NPN).

Type No. 44-150 PRESSURE REGULATOR, equipped with yoke for use with cylinder Type No. 41-150. (NPN).

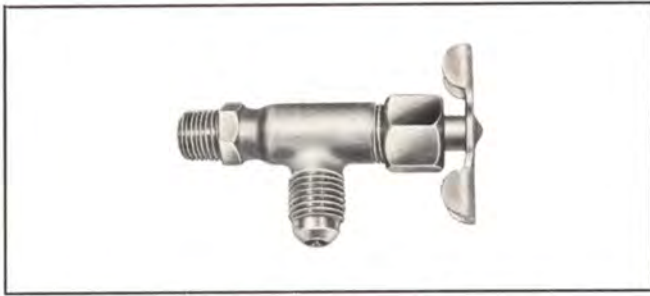

Type No. 32-150 NEEDLE VALVE, right angle type, has $\frac{1}{8}$ " IPS male thread, and side outlet is $\frac{1}{4}$ " OD copper tube. (NPN).



Type No. 33-150 BLEEDER VALVE, with key has $\frac{1}{8}$ " IPS male thread used wherever necessary when purging transmission line. (NPN).



Type No. 34-150 NIPPLE, close, $\frac{1}{8}$ " IPS, brass. (NPN).



Type No. 35-150 TUBE CUTTER, for tube sizes $\frac{1}{4}$ " OD to $1\frac{3}{8}$ " OD. (NPN).

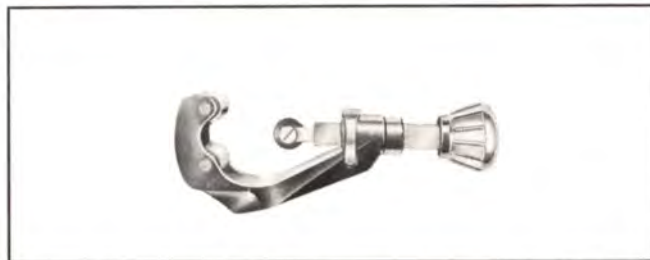

Type No. 36-150 TUBE CUTTER, for tube sizes $\frac{3}{4}$ " OD to $2\frac{1}{4}$ " OD. (NPN).



Type No. 38-150 POLYETHYLENE TAPE ($\frac{3}{4}$ " wide x 20 ft.) used for weather-proofing connectors. Polyethylene tape is the only plastic which should be used on Spir-O-line cable and connectors. (NPN).

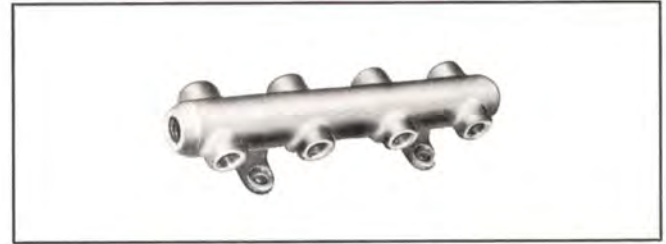

Type No. 39-150 MANIFOLD, has 10 ports $\frac{1}{8}$ " IPS female. (NPN).



Type No. 40-150 PIPE PLUG, hex head, $\frac{1}{8}$ " IPS male thread. (NPN).



Type No. 41-150 NITROGEN CYLINDER, 6.2 cu. ft., dry oil pumped nitrogen. (NPN).

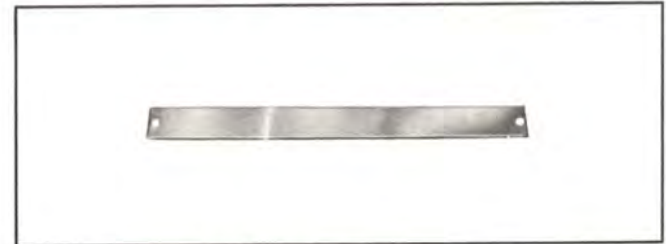

Type No. 42-150 GROUNDING STRAP, this consists of 12" of copper equipped with a hole in each end used to ground Spir-O-line from flanged type connector to tower. (NPN).



Type No. 43-150 NITROGEN CYLINDER, 112 cu. ft., dry oil pumped nitrogen. (NPN).



Type No. 45-150 FLARE FITTING, 1/4" OD copper tube, 1/8" IPS male includes flare nut. (Part No. 097 7583 00).



Type No. 47-150 NEEDLE VALVE, equipped with 1/8" IPS male thread. (NPN).



Type No. 48-150 PIPE PLUG, hex head, 1/4" IPS male thread. (NPN).



Type No. 93-500 MOUNTING SLEEVE, split, 1/2" size, used when fastening plain cable with wraplock to tower leg. (NPN).

Type No. 93-875 MOUNTING SLEEVE, split, 7/8" size, used when fastening plain cable with wraplock to tower leg. (NPN).

Type No. 93-1625 MOUNTING SLEEVE, split, 1 5/8" size, used when fastening plain cable with wraplock to tower leg. (NPN).



Type No. 50-150 ASSEMBLY for grounding 7/8" Spir-O-line at base of tower; Copper ground rod is 1/2" dia. and 6 feet long, copper wire is #10 AWG and 10 feet long. (NPN).

Type No. 59-150 ASSEMBLY for grounding 1 5/8" Spir-O-line. (NPN).



Type No. 24-150 PRESSURE GAUGE, 0-30 PSI with 1/8" IPS male thread. (Part No. 099 6723 00).



Type No. 21-150 GAS INLET VALVE has 1/8" IPS male thread. (Part No. 097 6901 00).

Type No. 70-150 GAS INLET ASSEMBLY — Includes Type No. 24-150 Pressure Gauge, Type No. 22-150 Tee, Type No. 34-150 Nipple, and Type No. 21-150 Gas Inlet Valve. (NPN).

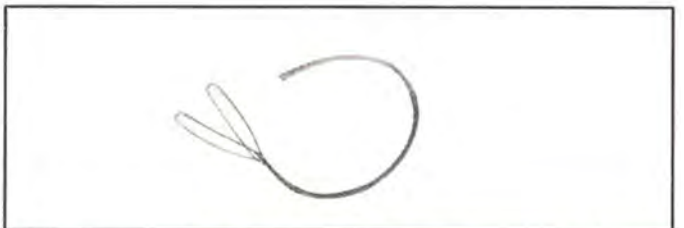

Type No. 90-875 CABLE GRIP, stainless steel, 7/8" size, for use on either plain or jacketed Spir-O-line. (NPN).

Type No. 90-1625 CABLE GRIP, stainless steel, 1 5/8" size, for use on either plain or jacketed Spir-O-line. (NPN).



Type No. 22-150 TEE, all outlets 1/8" IPS female. (NPN).



Type No. 308-375 $\frac{3}{8}$ " "O" RING GASKET, for Spir-O-lok Connectors. (NPN).

Type No. 308-500 $\frac{1}{2}$ " "O" RING GASKET, for Spir-O-lok Connectors. (NPN).

Type No. 308-875 $\frac{7}{8}$ " "O" RING GASKET, for Spir-O-lok Connectors. (NPN).

Type No. 308-1625 $1\frac{5}{8}$ " "O" RING GASKET, for Spir-O-lok Connectors. (NPN).



Type No. 19-150 WRAPLOCK, stainless steel $\frac{1}{2}$ " wide x 50 feet, used for attaching Spir-O-line and Spir-O-foam cables to tower or supporting members.

Type No. 20-150 WRAPLOCK, 100 feet. (Part No. 099 0501 00).



Type No. 91-1625 ANCHOR, vertical, $1\frac{5}{8}$ " size, plain sheath, for anchoring cable at top of tower. (NPN).

Type No. 91-875 for $\frac{7}{8}$ ". (NPN).



Type No. 143-375 $\frac{3}{8}$ " SPIR-O-LOK NUT ASSEMBLY. (NPN).

Type No. 143-500 $\frac{1}{2}$ " SPIR-O-LOK NUT ASSEMBLY. (NPN).

Type No. 143-875 $\frac{7}{8}$ " SPIR-O-LOK NUT ASSEMBLY. (NPN).

Type No. 143-1625 $1\frac{5}{8}$ " SPIR-O-LOK-NUT ASSEMBLY. (NPN).



Type No. 94-875 ANCHOR, horizontal, $\frac{7}{8}$ " size, plain sheath, for anchoring cable at building. (NPN).

Type No. 94-1625 ANCHOR, horizontal, $1\frac{5}{8}$ " size, plain sheath, for anchoring cable at building. (NPN).

Type No. 92-875 ANCHOR, horizontal, $\frac{7}{8}$ " size, jacketed sheath, for anchoring cable at building. (NPN).

Type No. 92-1625 ANCHOR, horizontal, $1\frac{5}{8}$ " size, jacketed sheath, for anchoring cable at building. (NPN).



Type No. 196-875 GROUNDING CLAMP ASSEMBLY, $\frac{7}{8}$ " size, for grounding cable at base of tower. (NPN).

Type No. 196-1625 GROUNDING CLAMP ASSEMBLY, $1\frac{5}{8}$ " size, for grounding cable at base of tower. (NPN).

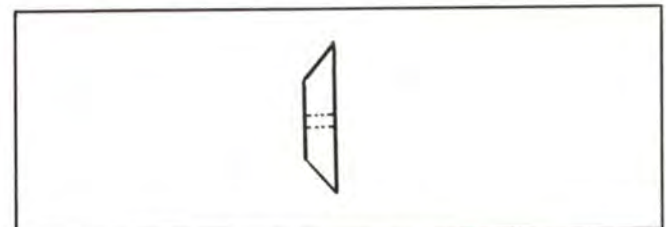

Type No. 83-150 SINGLE SIDED CUTTING WHEEL, for special applications. $\frac{7}{8}$ " for use with Type No. 35-150. (NPN).

Type No. 84-150 Same as above except $1\frac{5}{8}$ " with Type No. 36-150. (NPN).



Type No. 62-150 CABLE CLIP, for use with $\frac{1}{2}$ " Spir-O-foam. (NPN).

Type No. 64-150 CABLE CLIP, for use with $\frac{7}{8}$ " Spir-O-foam. (NPN).



Type No. 23-150 MANIFOLD, has 6 ports, 1/8" IPS female. (NPN).



Type No. 25-150 COPPER TUBE, soft, 1/4" OD (specify length). Comes in 25' coils. (NPN).

**PRODELIN RIGID "800" 7/8" — 50 OHM
COPPER TRANSMISSION LINE AND ACCESSORIES**

In Accordance With EIA Standard RS-225

7/8" — 50 OHM CHARACTERISTICS

Outer Conductor: High Conductivity Copper Tube — .875 O.D. x .785 I.D.

Inner Conductor: High Conductivity Copper Tube — .341 O.D. x .291 I.D.

Velocity — Percent: 99.7

60 cycle, Peak Test Voltage, KV: 6

Insulator Supports: Teflon Pins, 15" spacing

Weight/20 ft. lgth: 11 lbs. 10 oz.

Shipping Weight: 245 lbs.

No. Lines/Carton: 16

Carton Size: 12" x 12" x 243"

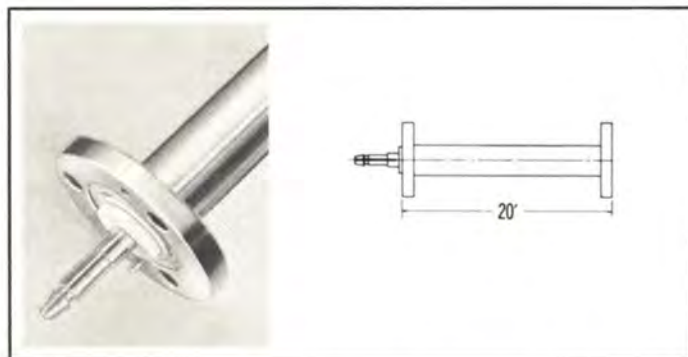

TYPE NO. 100-815 (NPN) — Line assembly, 20 ft. exact length, flanged both ends. Includes anchor insulator connector assembly, "O" ring and hardware. Weight: 11 lbs. 10 oz.

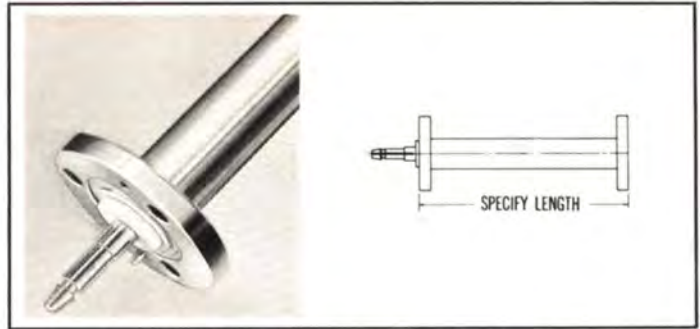

TYPE NO. 102-815 (NPN) — Line assembly, length to be specified, flanged both ends. Includes anchor insulator connector assembly, "O" ring and hardware. Weight: 10 oz. + 5 1/2 oz./ft.



TYPE NO. 103-815 (NPN) — Line assembly, length to be specified, no flanges, hardware or connector. Weight: 5 1/2 oz./ft.

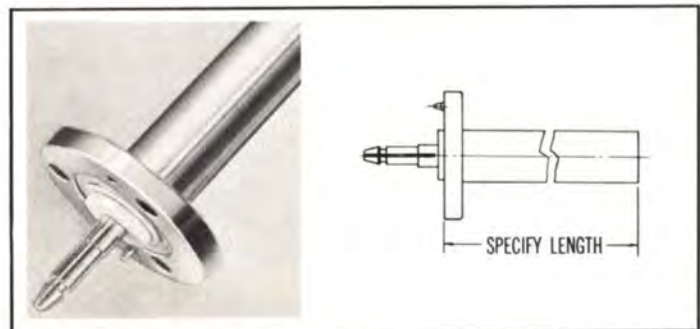

TYPE NO. 105-815 (NPN) — Line assembly, length to be specified, flanged one end. Includes anchor insulator connector assembly, "O" ring and hardware. Weight: 5 1/2 oz. + 5 1/2 oz./ft.

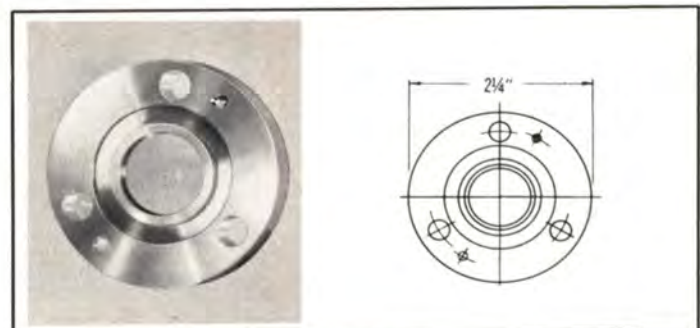

TYPE NO. 300-815 (NPN) — Flange, fixed, for silver brazing. Includes silver solder ring insert. Weight: 4 oz.

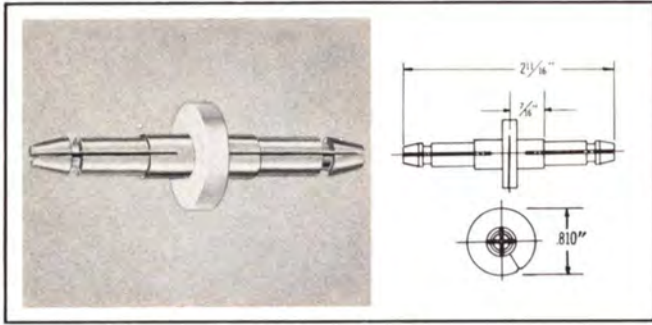

TYPE NO. 302-815 (NPN) — Anchor insulator connector assembly, silver plated. Weight: 1/2 oz.

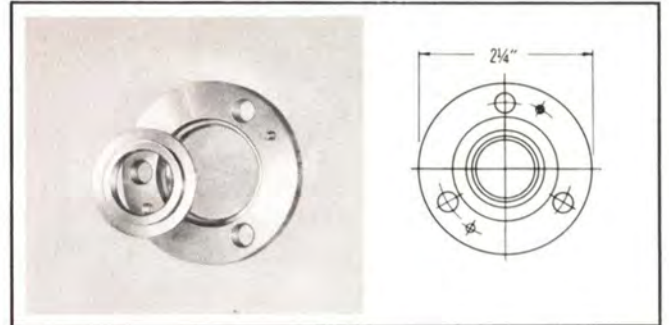

TYPE NO. 324-815 (NPN) — Flange, swivel, for silver brazing. Includes silver solder ring insert. Weight: 4 3/4 oz.



TYPE NO. 308-815 (NPN) — "O" ring for 7/8" flanges Type No. 300-815 and Type No. 324-815.

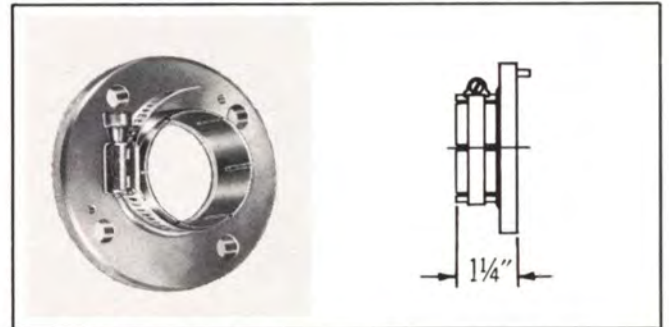

TYPE NO. 325-815 (NPN) — Adapter assembly, flanged to unflanged line, unpressurized, clamp type, for indoor use. Includes hardware. Weight: 8 oz.



TYPE NO. 315-815 (NPN) — Hardware set for 7/8" flange. Consists of 3 each stainless steel bolts, nuts and lockwashers, 1/4-20 x 1" lg. Weight: 1 oz.

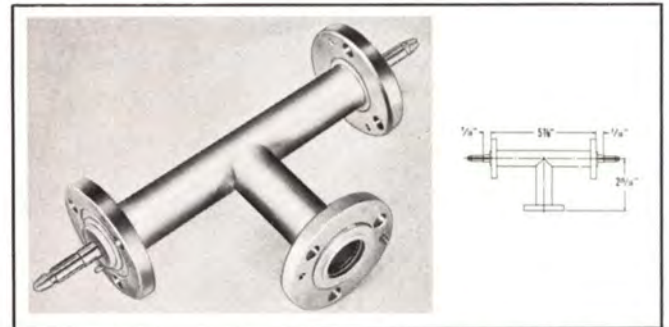

TYPE NO. 420-815 (NPN) — Tee assembly, swivel flanges all legs, two anchor insulator-connectors, "O" ring and hardware. Weight 1 lb. 9 oz.

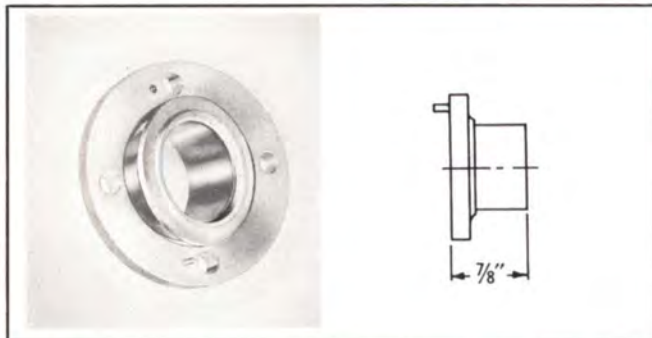

TYPE NO. 322-815 (NPN) — Adapter assembly, flanged to unflanged line, soft solder type, pressurized. No anchor insulator-connector, "O" ring or hardware. Weight: 5 1/2 oz.



TYPE NO. 448-815 (NPN) — Elbow assembly, miter, 45 degree, swivel flanged, male-female. Includes one anchor insulator-connector, "O" ring and hardware. Weight: 1 lb. 1 oz.

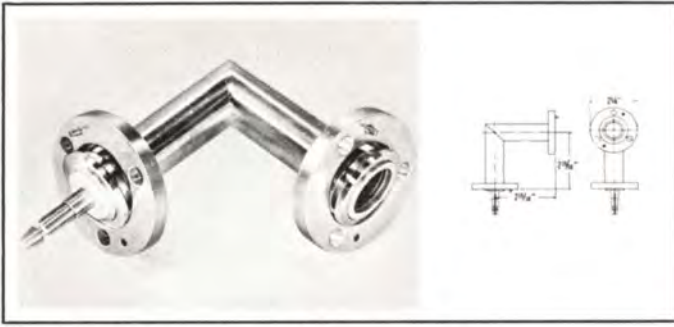

TYPE NO. 494-815 (NPN) — Elbow, miter, 90 degree, male-female, swivel flanged. Includes one anchor insulator-connector, "O" ring and hardware. Weight: 1 lb. 1 oz.

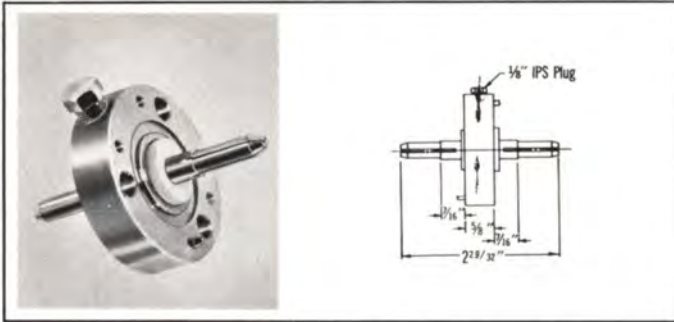

Type No. 500-815 (NPN) — Gas barrier, with "O" ring and extra long hardware. Incorporates 1/8" IPS gas inlet port. Weight: 13 oz.

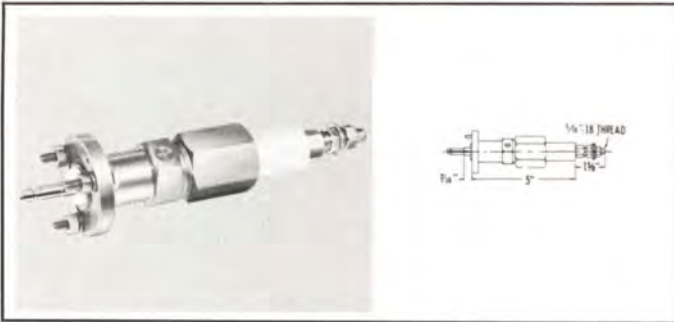

TYPE NO. 505-815 (NPN) — End seal assembly, flanged with gas inlet port, includes "O" ring and hardware. Weight: 1 lb.

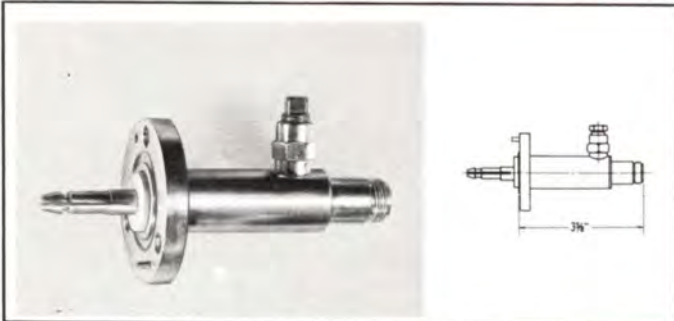

TYPE NO. 521-815 (NPN) — Adapter, EIA flange to type "N" female (UG-23D/U). Includes anchor insulator-connector, "O" ring and hardware. Incorporates 1/8" IPS port. Weight: 11 oz.

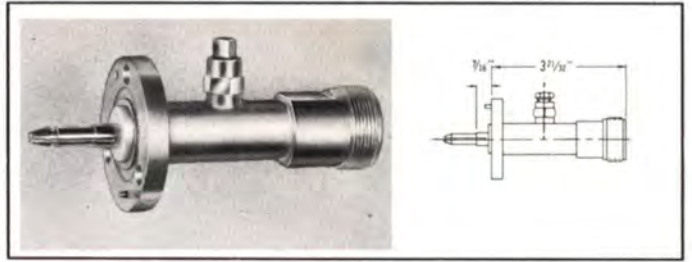

TYPE NO. 536-815 (NPN) — Adapter, EIA flange to "LC" female (UG-215/U). Includes one anchor insulator-connector, "O" ring and hardware. Incorporates 1/8" IPS port. Weight: 14 oz.

PRODELIN RIGID "800" 1 5/8" — 50 OHM
COPPER TRANSMISSION LINE AND ACCESSORIES
 In Accordance With EIA Standard RS-225

1 5/8" — 50 OHM CHARACTERISTICS
Outer Conductor: High Conductivity Copper Tube — 1.625 O.D. x 1.527 I.D.
Inner Conductor: High Conductivity Copper Tube — .664 O.D. x .588 I.D.
Velocity — Percent: 99.7
60 cycle, Peak Test Voltage, KV: 11
Insulator Supports: Teflon Pins, 30" spacing
Weight/20 ft. lgth.: 28 lbs.
Shipping Weight: 280 lbs.
No. Lines/Carion: 8
Carion Size: 12" x 12" x 243"

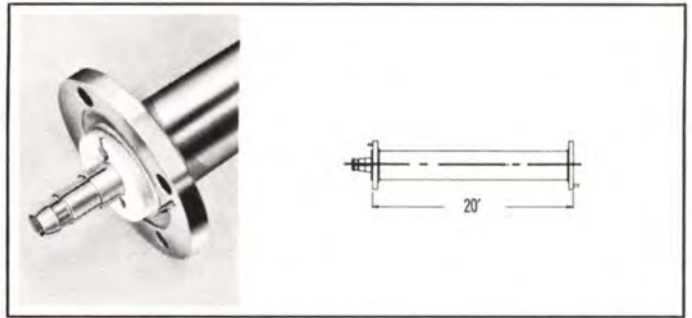

TYPE NO. 100-825 (Part No. 097 7081 —) — Line assembly, 20 ft. exact length, flanged both ends. Includes anchor insulator-connector assembly, "O" ring and hardware. Weight: 26 lbs.

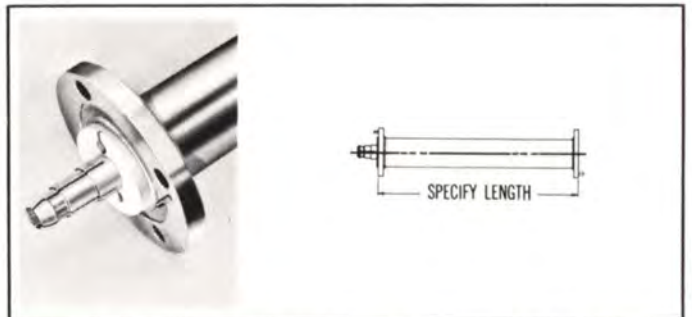

TYPE NO. 102-825 (NPN) — Line assembly, length to be specified, flanged both ends. Includes anchor-insulator connector assembly, "O" ring and hardware. Weight: 2 lbs. + 1 lb. 3 oz./ft.

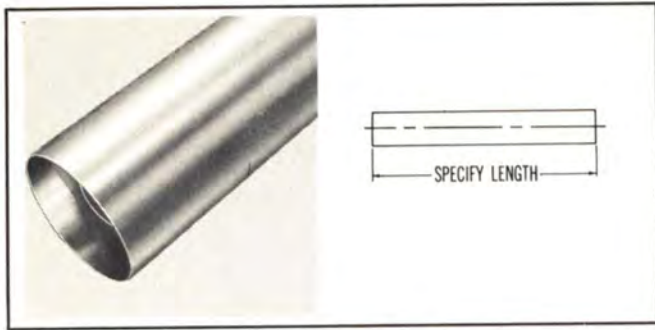

TYPE NO. 103-825 (NPN) — Line assembly, length to be specified, no flanges, hardware or connector. Weight: 1 lb. 3 oz./ft.

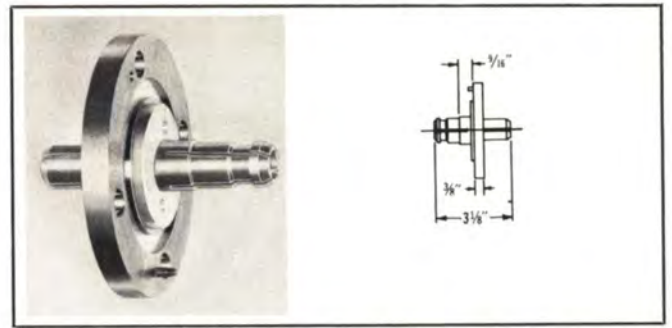

TYPE NO. 304-825 (NPN) — Adapter, flange type, includes anchor insulator-connector assembly. Used for connecting flanged 50 ohm EIA line to flanged 51.5 ohm RMA-VHF line with inner conductor .625 O.D. x .568 I.D. Supplied with "O" ring and hardware. Weight: 1 lb. 3 oz.



TYPE NO. 105-825 (NPN) — Line assembly, length to be specified, flanged one end. Includes anchor insulator-connector assembly, "O" ring and hardware. Weight: 1 lb. 3 1/2 oz. + 1 lb. 3 oz./ft.

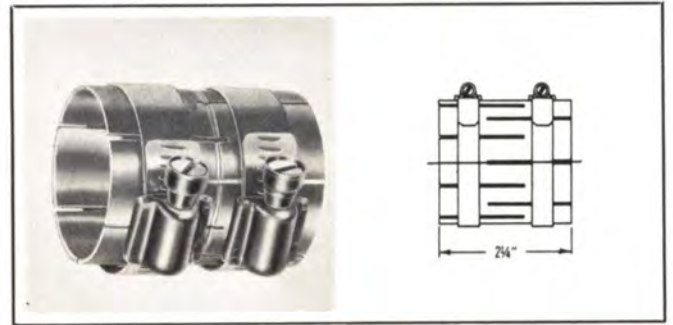

TYPE NO. 305-825 (NPN) — Coupling, straight clamp type, unpressurized. Includes 2 tube clamps. No inner conductor connector. Weight: 5 1/2 oz.

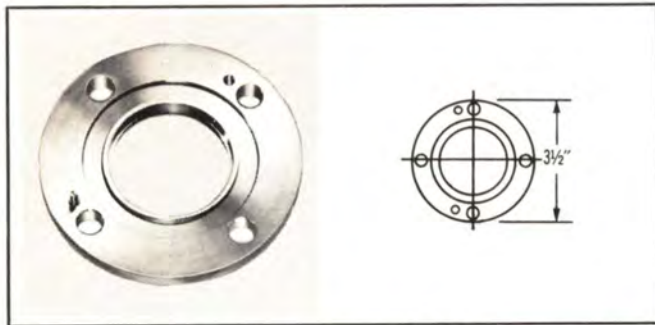

TYPE NO. 300-825 (Part No. 099 0458 00) — Flange, fixed, 3 1/2" dia., for silver brazing. Includes silver solder ring insert. Weight: 12 oz.

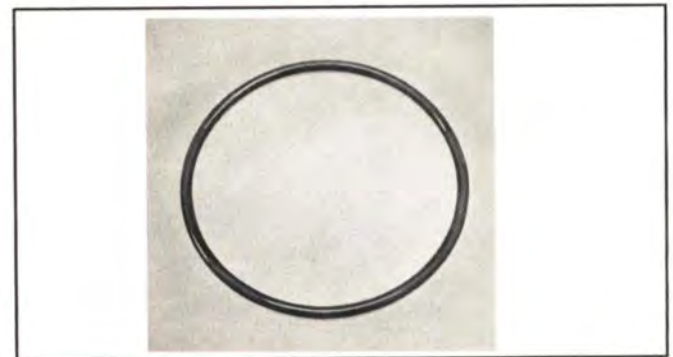

TYPE NO. 308-825 (Part No. 097 7258 00) — "O" ring gasket for 1 5/8" flanges, Type No. 300-825 and Type No. 324-825.

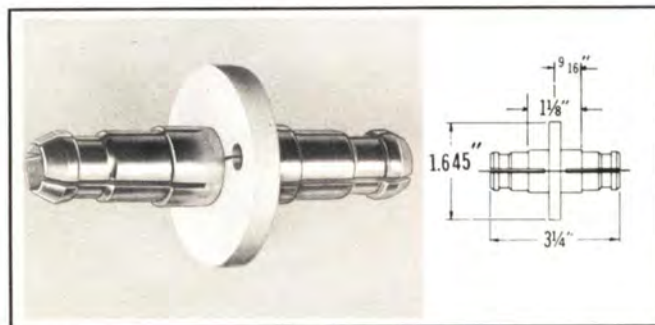

TYPE NO. 302-825 (Part No. 097 7084 00) — Anchor insulator-connector assembly, silver plated. Weight: 3 1/2 oz.

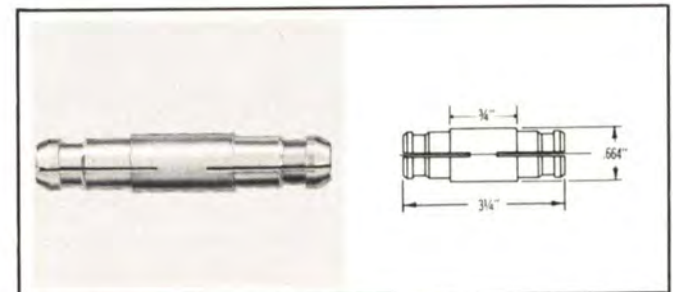

TYPE NO. 310-825 (Part No. 099 0459 00) — Inner conductor connector, silver plated. Weight: 2 1/2 oz.

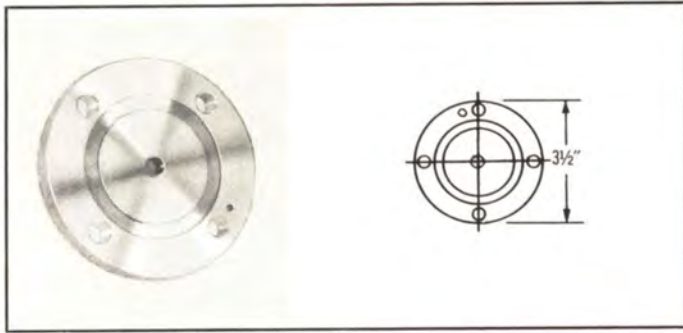

TYPE NO. 312-825 (NPN) — Cover plate, brass, with $\frac{1}{8}$ " IPS gas inlet port and plug. No hardware. Weight: 1 lb.

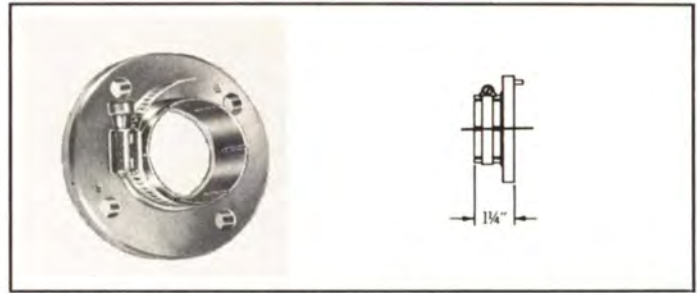

TYPE NO. 325-825 (NPN) — Adapter assembly, flanged to unflanged line, unpressurized, clamp type, for indoor use, includes hardware. Weight: 1 lb 2 oz.



TYPE NO. 315-825 (NPN) — Hardware set for $1\frac{5}{8}$ " flanges. Consists of 4 ea. stainless steel bolts, nuts and lockwashers, $\frac{5}{16}$ "-18 x $1\frac{1}{2}$ " lg. Weight: $3\frac{1}{2}$ oz.

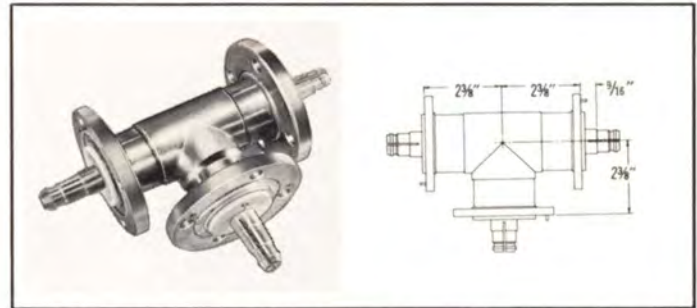

TYPE NO. 420-825 (NPN) — Tee assembly, reinforced, swivel flanges on all three legs, $2\frac{3}{8}$ " center lines, affixed male anchor insulators all legs, includes "O" rings and hardware. Weight: 4 lbs. 1 oz.

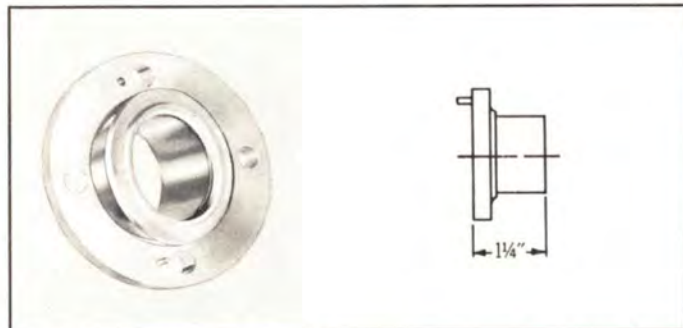

TYPE NO. 322-825 (NPN) — Adapter assembly, flange, swivel to unflanged line, soft solder type, pressurized. No anchor insulator-connector, "O" ring or hardware. Weight: 14 oz.

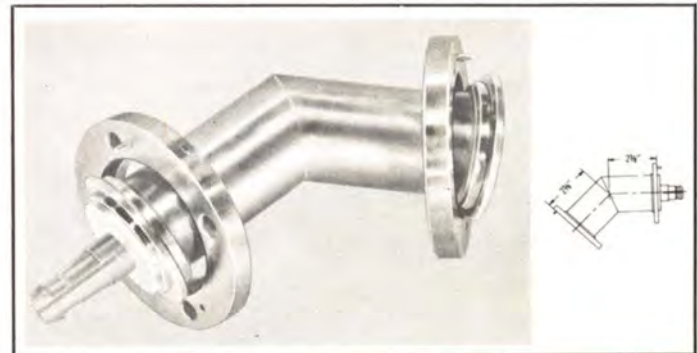

TYPE NO. 448-825 (Part No. 097 7511 00) — Elbow assembly, miter, 45 degree, female, swivel flanged. Includes one anchor insulator-connector, "O" ring and hardware. Weight: 2 lbs. 12 oz.

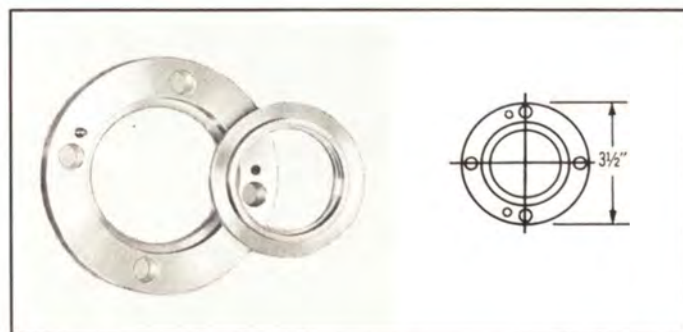

TYPE NO. 324-825 (NPN) — Flange, swivel, $3\frac{1}{2}$ " dia., for silver brazing. Includes silver solder ring insert. Weight: 13 oz.

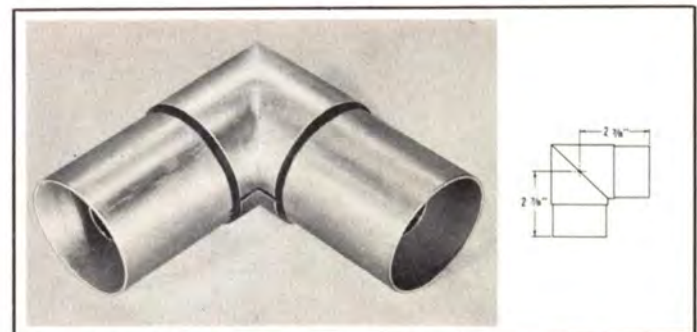

TYPE NO. 493-825 (NPN) — Elbow assembly, miter, 90 degree, female, reinforced, no flanges, equal legs. Inner conductor each leg cutback $\frac{1}{8}$ " from face of outer conductor. Weight: 15 oz.

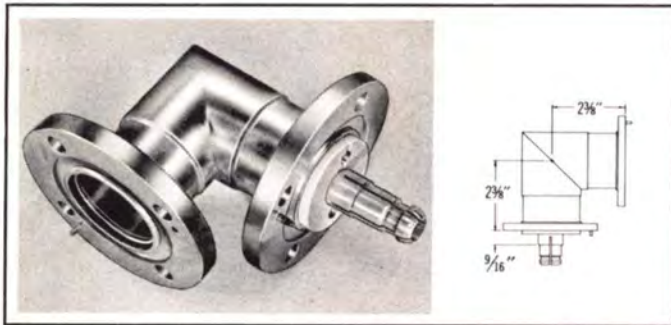

TYPE NO. 494-825 (Part No. 097 6739 00) — Elbow assembly, miter, 90 degree, male-female, reinforced, swivel flanged. Includes one affixed male anchor insulator, "O" ring and hardware. Weight: 2 lbs. 14 oz.

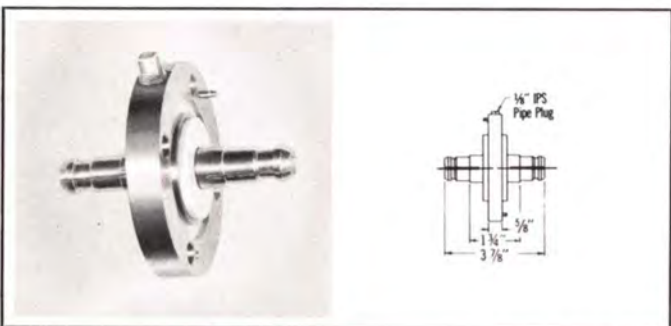

TYPE NO. 500-825 (Part No. 097 7085 00) — Gas barrier, with "O" ring and 2" long hardware. Incorporates 1/8" IPS gas inlet port. Weight: 1 lb. 10 oz.

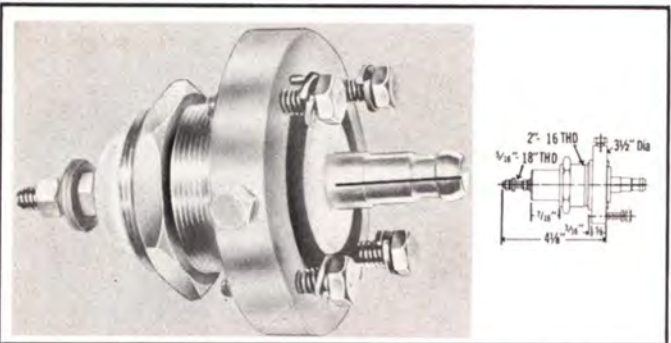

TYPE NO. 505-825 (Part No. 099 0460 00) — End seal assembly, flanged with gas inlet port, includes "O" ring and hardware. Weight: 2 lbs. 10 oz.

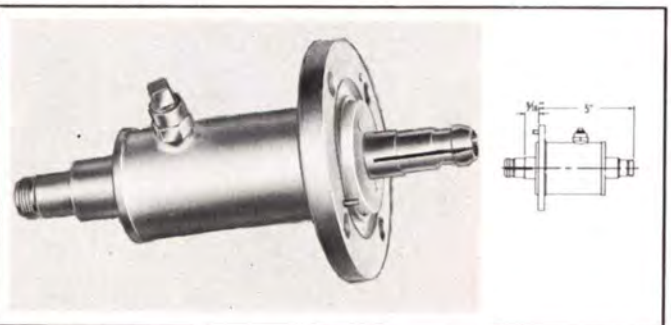

TYPE NO. 521-825 (NPN) — Adapter, EIA flange to type "N" female (UG-23D/U). Includes anchor insulator, "O" ring and hardware. Incorporates 1/8" IPS port. Weight: 2 lbs.

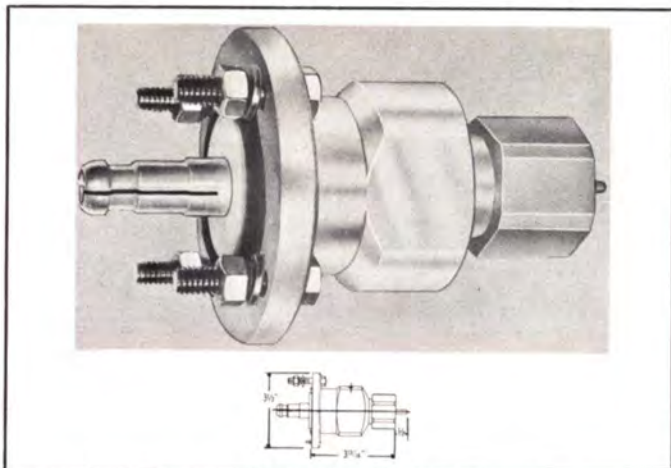

TYPE NO. 535-825 (NPN) — Adapter, EIA flange to "LC" male (UG-154/U). Includes anchor insulator, "O" ring and hardware. Incorporates 1/8" IPS port. Weight: 2 lbs. 12 oz.

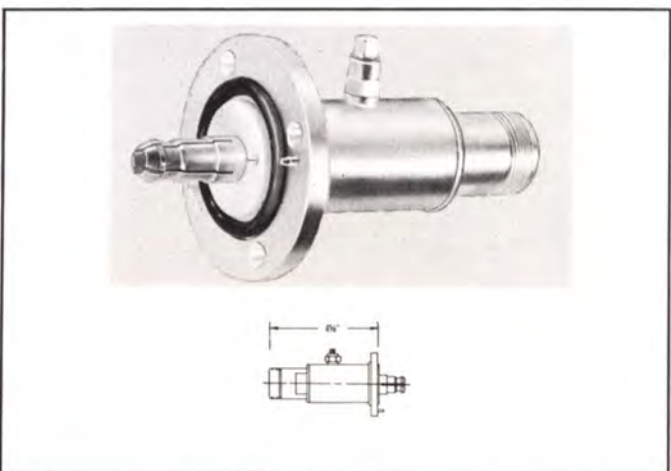

TYPE NO. 536-825 (NPN) — Adapter, EIA flange to "LC" female (UG-215/U). Includes anchor insulator, "O" ring and hardware. Incorporates 1/8" IPS port. Weight: 1 lb. 10 oz.

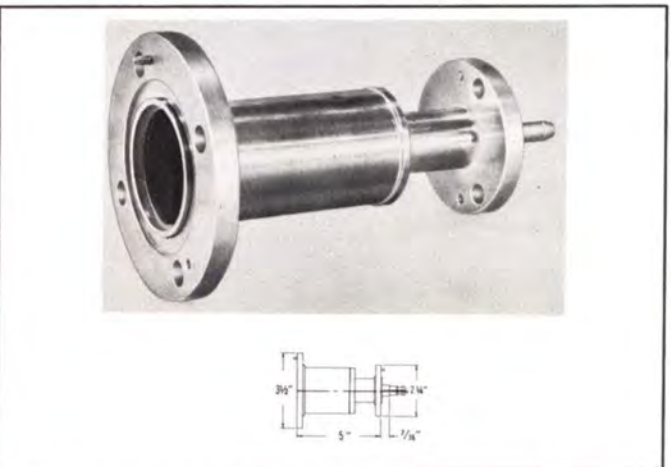

TYPE NO. 811-825 (NPN) — Reducer, step type, 1 5/8" to 7/8" 50 ohm, fixed flanges. Includes one 7/8" anchor insulator-connector assembly, "O" ring and hardware. Weight: 1 lb. 12 oz.

PRODELIN RIGID "800" 3 1/8" — 50 OHM

COPPER TRANSMISSION LINE AND ACCESSORIES

In Accordance With EIA Standard RS-225

3 1/8" — 50 OHM CHARACTERISTICS

Outer Conductor: High Conductivity Copper Tube —
3.125 O.D. x 3.027 I.D.

Inner Conductor: High Conductivity Copper Tube —
1.315 O.D. x 1.231 I.D.

Velocity — Percent: 99.7

60 cycle, Peak Test Voltage, KV: 19

Insulator Supports: Teflon Pins, 60" spacing

Weight/20 ft. lgth.: 54.5 lbs.

Shipping Weight: 270 lbs.

No. Lines/Carton: 4

Carton Size: 12" x 12" x 243"

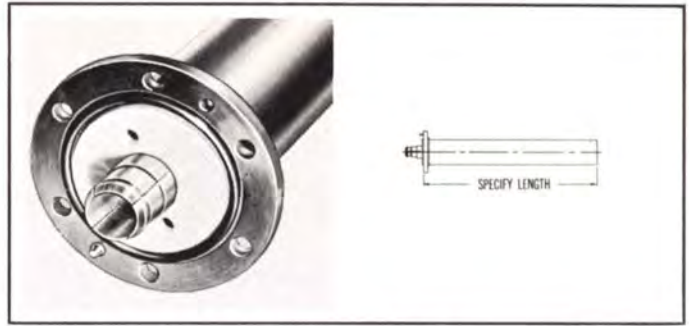

TYPE NO. 105-835 (NPN) — Line assembly, length to be specified, flanged one end. Includes anchor insulator-connector assembly, "O" ring and hardware. Weight: 3 lbs. + 2 1/2 lbs./ft.

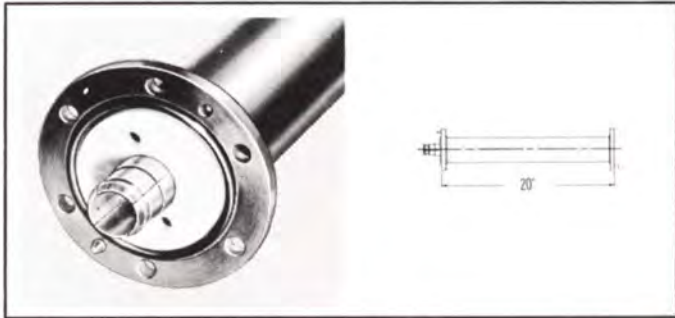

TYPE NO. 100-835 (Part No. 097 6631 —) — Line assembly, 20 ft. exact length flanged both ends. Includes anchor insulator-connector assembly, "O" ring and hardware. Weight: 54 1/2 lbs.

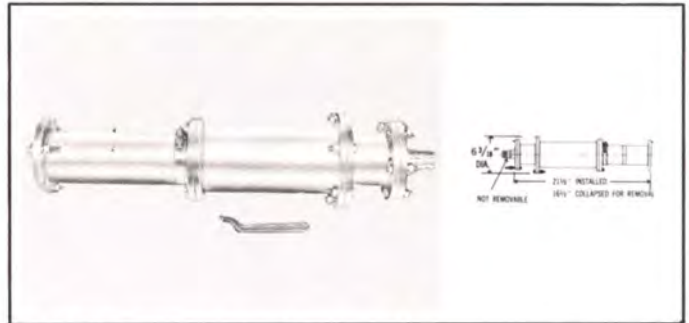

TYPE NO. 120-835 (NPN) — Breakaway section, EIA flanged both ends, permits separating the transmission line at any convenient point. Pressure tight. Weight: 14 lbs.

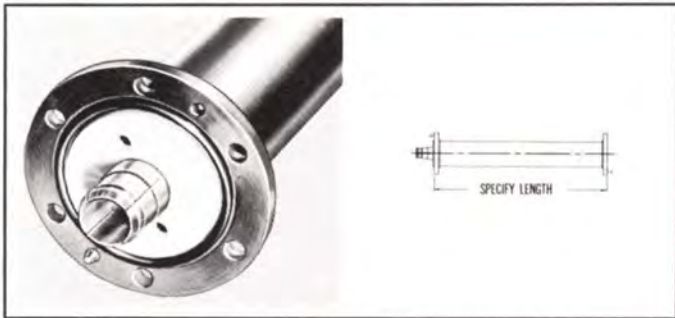

TYPE NO. 102-835 (NPN) — Line assembly, length to be specified, flanged both ends. Includes anchor insulator-connector assembly, "O" ring and hardware. Weight: 4 1/2 lbs + 2 1/2 lbs./ft.

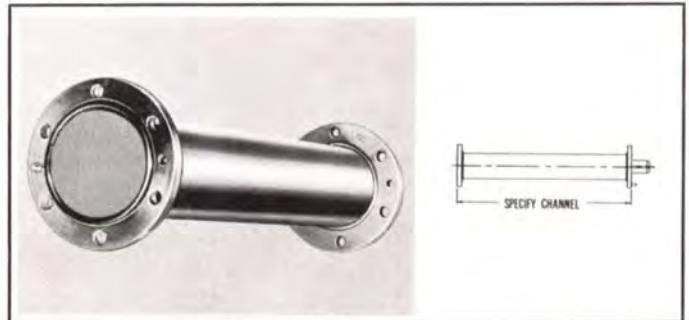

TYPE NO. 130-835 (NPN) — Transformer, 1/4 wave, used to join 50 ohm line to 51.5 ohm RMA line. Specify channel from 2 to 13. Connector for 51.5 ohm end supplied. Weight varies with channel.

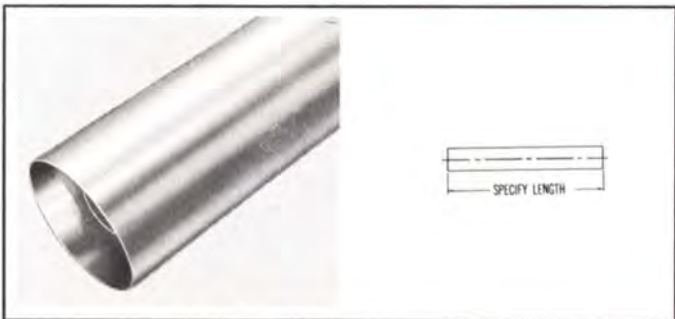

TYPE NO. 103-835 (NPN) — Line assembly, length to be specified, no flanges, hardware or connector. Weight: 2 1/2 lbs./ft.

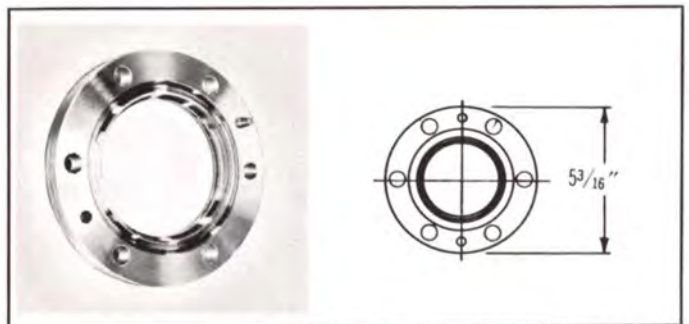

TYPE NO. 300-835 (Part No. 097 6944 00) — Flange, fixed, 5 3/8" dia., for silver brazing. Includes silver solder ring insert. Weight: 1 lb. 10 oz.

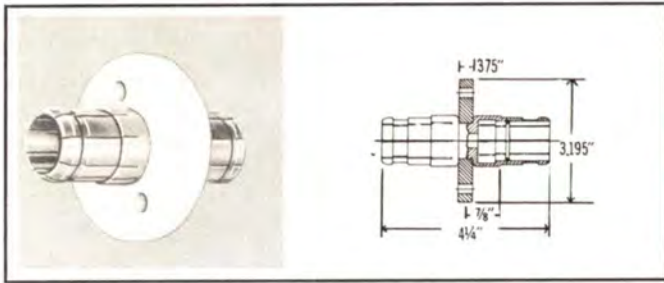

TYPE NO. 302-835 (NPN) — Anchor insulator-connector assembly, spring loaded, silver plated.

TYPE NO. 303-835 (NPN) — Same as 302-835 except contact area is finished with Prodelube #8. Weight: 12 oz.

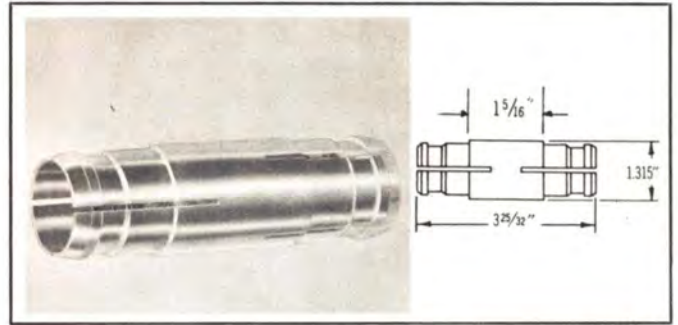

TYPE NO. 310-835 (Part No. 097 6635 00) — Inner conductor connector only, silver plated, spring loaded. Used with Type No. 305-835. Weight: 7 oz.

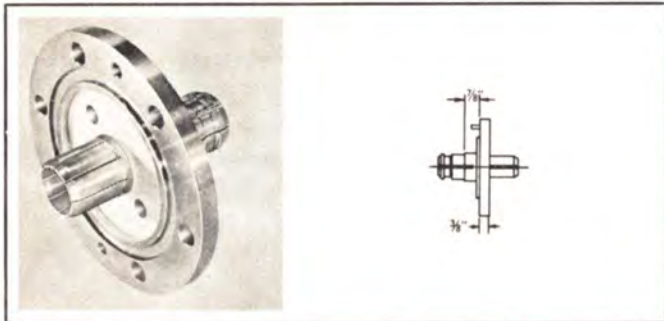

TYPE NO. 304-835 (NPN) — Adapter, flange type, includes anchor insulator-connector. Used for connecting flanged, 50 ohm EIA line to flanged 51.5 ohm RMS-VHF line with inner conductor 1.200 O.D. x 1.136 I.D. Supplied with "O" ring and hardware. Weight: 2 lbs. 9 oz.

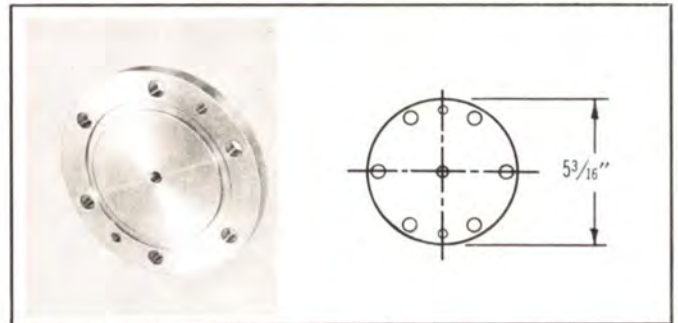

TYPE NO. 312-835 (NPN) — Cover plate, brass, with 1/8" IPS gas inlet port and plug. No hardware. Weight: 2 lbs. 3 oz.

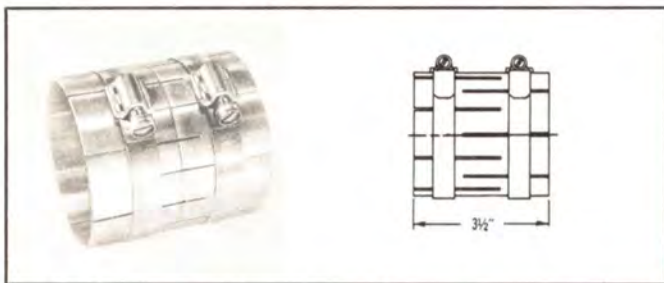

TYPE NO. 305-835 (NPN) — Coupling, straight, clamp type, unpressurized. Includes 2 tube clamps. No inner conductor connector. Does not increase lgth. O.C. Weight: 1 lb. 2 oz.

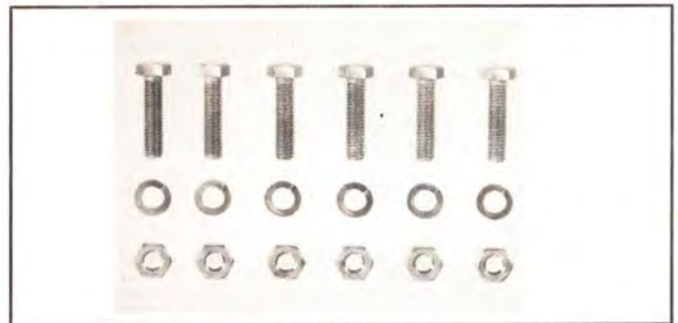

TYPE NO. 315-835 (NPN) — Hardware set for 3 1/8" flanges. Consists of 6 ea. stainless steel bolts, nuts and lockwashers, 3/8"-16 x 1 1/2" lg. Weight: 8 1/2 oz.



TYPE NO. 308-835 (Part No. 097 6742 00) — "O" ring gasket for 3 1/8" flanges, Type No. 300-835 and Type No. 324-835.

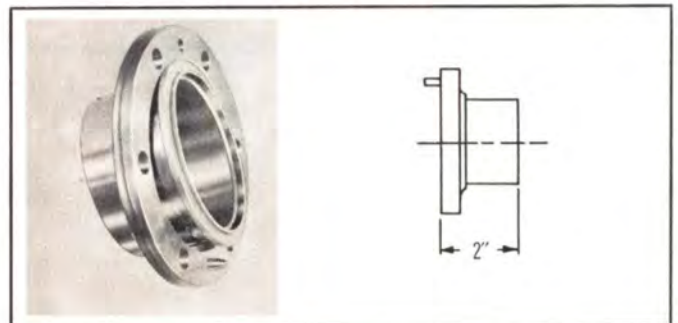

TYPE NO. 322-835 (NPN) — Adapter assembly, flanged to unflanged line, soft solder type, pressurized. No anchor insulator-connector, "O" ring or hardware. Weight: 2 lbs.

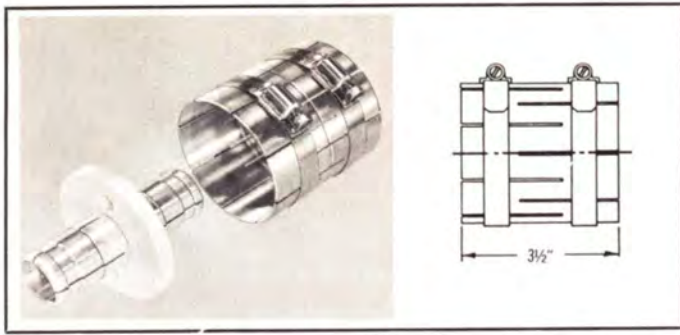

TYPE NO. 323-835 (NPN) — Coupling assembly, straight, clamp type, unpressurized. Includes inner conductor-connector assembly. (Special). Weight: 1 lb. 12 oz.

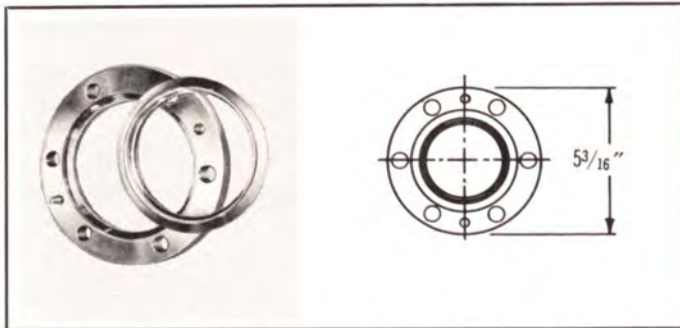

TYPE NO. 324-835 (NPN) — Flange, swivel, 5 3/16" dia., for silver brazing. Includes silver solder ring insert. Weight: 1 1/2 lbs.

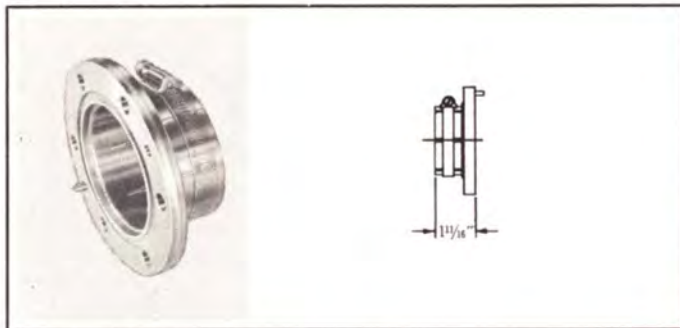

TYPE NO. 325-835 (NPN) — Adapter assembly, flanged to unflanged line, unpressurized, clamp type, for indoor use, includes hardware. Weight: 2 1/2 lbs.

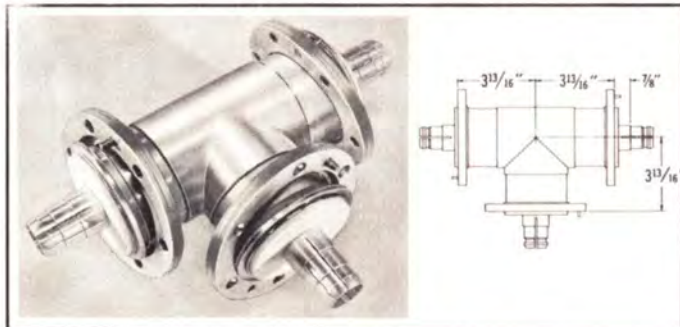

TYPE NO. 420-835 (NPN) — Tee assembly, reinforced, swivel flanges on all three legs, 3 13/16" center lines, affixed male anchor insulators all legs, includes "O" rings and hardware. Weight: 10 1/2 lbs.

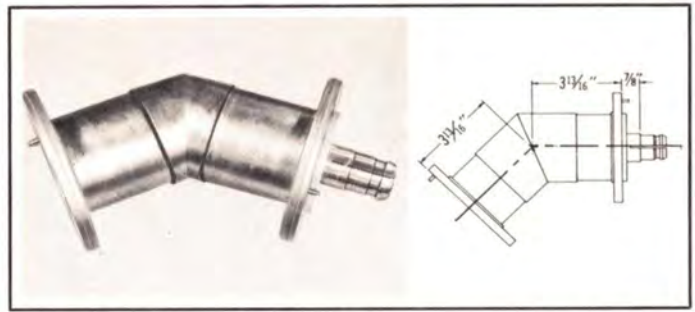

TYPE NO. 448-835 (Part No. 097 6633 00) — Elbow assembly, miter, 45 degree, female, reinforced, swivel flanged. Includes one anchor insulator-connector, "O" ring and hardware. Weight: 7 lbs.

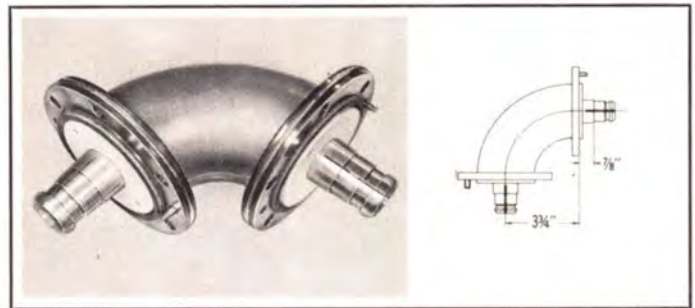

TYPE NO. 485-835 (NPN) — Elbow assembly, sweep, 90 degree, cast bronze, swivel flanged. Includes affixed male anchor insulator-connectors, "O" ring and hardware. Weight: 8 lbs. 4 oz.

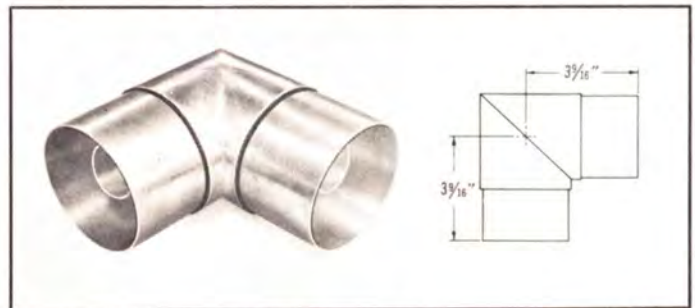

TYPE NO. 493-835 (NPN) — Elbow assembly, miter, 90 degree, female, reinforced, no flanges, equal legs. Inner conductor cut-back 1/8" from face of outer conductor. Weight: 3 lbs.



TYPE NO. 494-835 (Part No. 097 6986 —) — Elbow assembly, miter, 90 degree, male-female, reinforced, swivel flanged. Includes one affixed male anchor insulator-connector, "O" ring and hardware. Weight: 7 lbs. 12 oz.

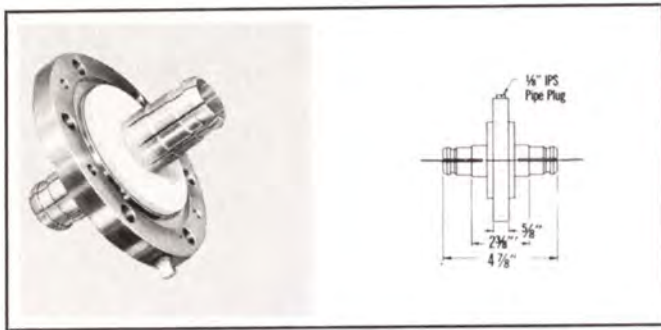

TYPE NO. 500-835 (Part No. 097 6725 00) — Gas barrier, with "O" ring gasket and 2 1/4" long hardware. Incorporates 1/8" IPS gas inlet port. Weight: 3 lbs. 13 oz.

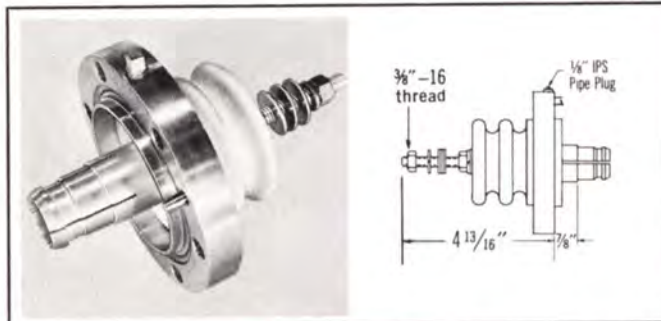

TYPE NO. 505-835 (Part No. 099 0461 00) — End seal assembly, flanged, with gas inlet port, includes "O" ring gasket and hardware. Weight: 4 lbs. 6 oz.

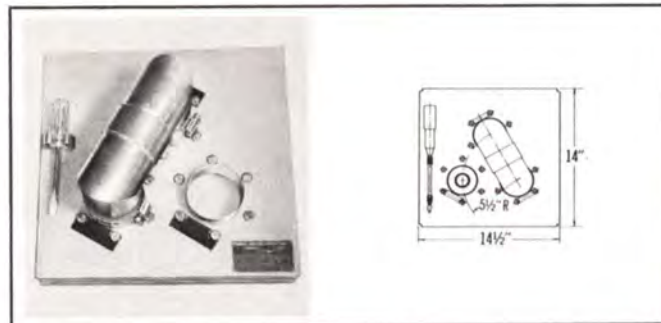

TYPE NO. 516-835 (NPN) — Manual transfer patch panel assembly, 3 pole, one 180° connector, includes 3 anchor connectors. Screwdriver mounted on panel. Not pressurized. Weight: 24 lbs.

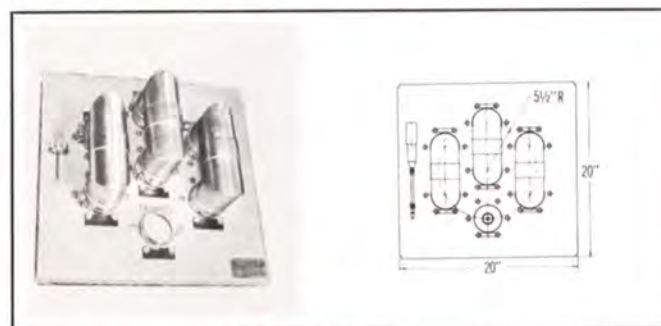

TYPE NO. 517-835 (NPN) — Manual transfer patch panel assembly, 7 pole, three 180° connectors, includes 7 anchor connectors. Screwdriver mounted on panel. Not pressurized. Weight: 49.5 lbs.

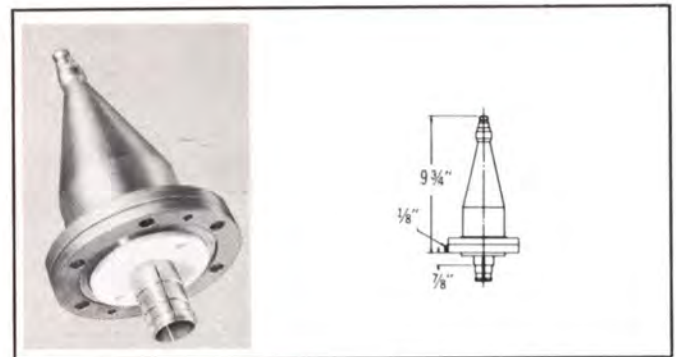

TYPE NO. 521-835 (NPN) — Taper, 3 1/8" — 50 ohm to Type "N" female. Includes anchor insulator assembly, "O" ring, nuts and lockwashers. Weight: 7 1/2 lbs.

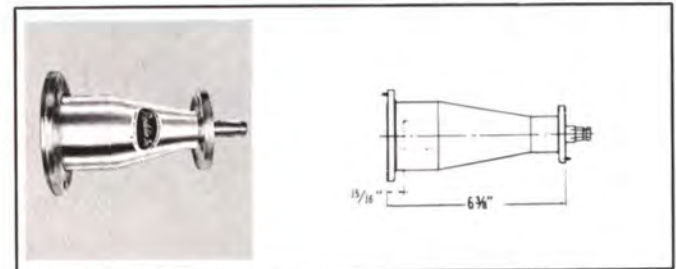

TYPE NO. 801-835 (Part No. 097 7504 00) — Taper, 3 1/8" — 50 ohm to 1 5/8" — 50 ohm. 1 5/8" anchor connector. "O" ring and hardware furnished. Weight: 4 lbs. 2 oz.

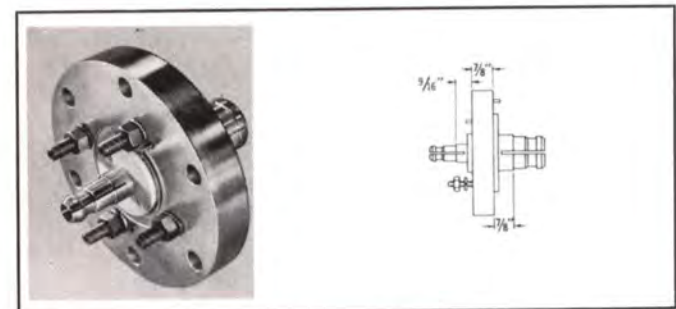

TYPE NO. 810-835 (NPN) — Reducer, flange type, 3 1/8" to 1 5/8" 50 ohm, incorporates 3 1/8" and 1 5/8" male anchor insulator connector. Includes 1 5/8" "O" ring, studs, nuts and lockwashers. Weight: 4 lbs. 13 oz.

PRODELIN RIGID "800" 1 5/8" — 50 OHM

ALUMINUM TRANSMISSION LINE AND ACCESSORIES Using EIA Flange Connector

1 5/8" — 50 OHM CHARACTERISTICS

Outer Conductor: Aluminum, Alloy 1100-H18, 1.625 O.D. x 1.527 I.D.

Inner Conductor: High Conductivity Copper Tube—.664 O.D. x .588 I.D.

Velocity — Percent: 99.7

60 cycle, Peak Test Voltage, KV: 11

Insulator Supports: Teflon Pins, 30" spacing

Weight/20 ft. lgth.: 13 lbs. 3 oz.

Shipping Weight: 160 lbs.

No. Lines/Carton: 8

Carton Size: 9" x 16" x 24 3/4"

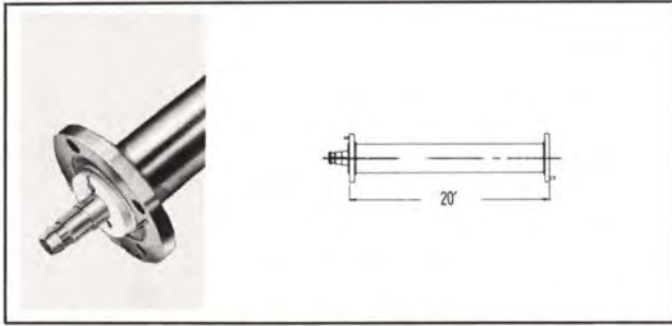

TYPE NO. 100-925 (NPN) — Line assembly, 20 ft. exact length, flanged both ends. Includes anchor insulator-connector assembly, “O” ring and hardware. Weight: 13 lbs. 3 oz.

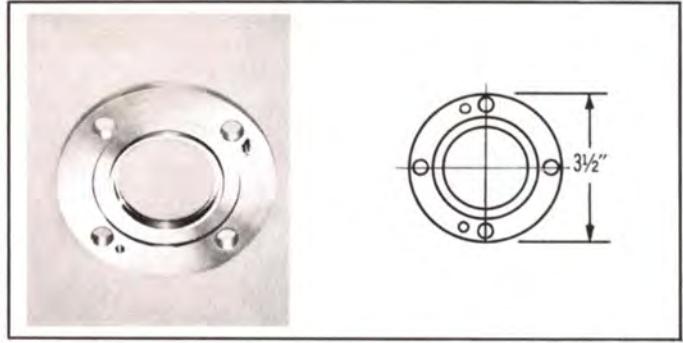

TYPE NO. 300-925 (NPN) — Flange, fixed, 6061 alloy. Weight: 4 1/2 oz.

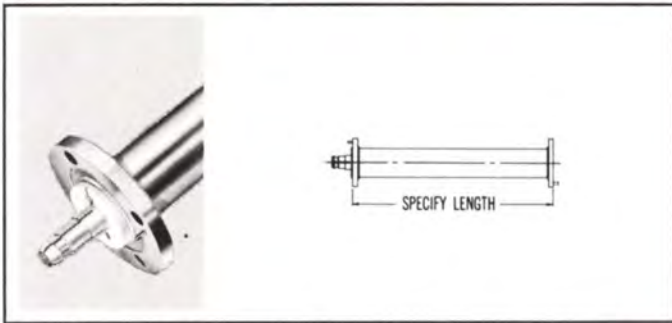

TYPE NO. 102-925 (NPN) — Line assembly, length to be specified, flanged both ends. Includes anchor insulator assembly, “O” ring and hardware. Weight: 1 lb. 3 oz. + 10 oz./ft.

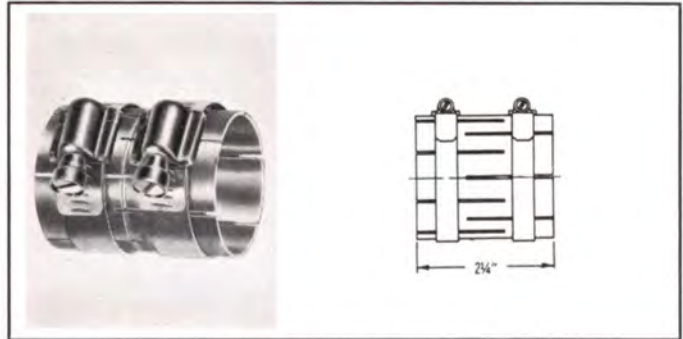

TYPE NO. 305-925 (NPN) — Coupling, straight, zinc plated, clamp type, unpressurized. Includes 2 tube clamps. No inner conductor connector. Weight: 5 1/2 oz.

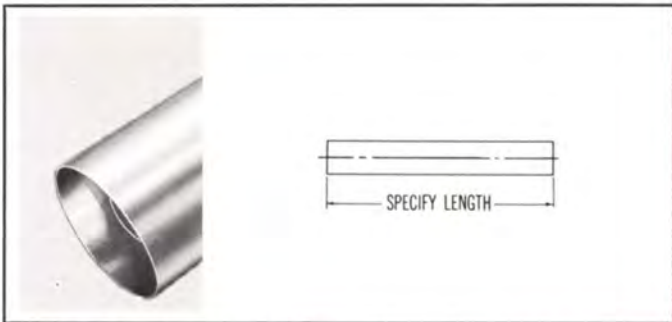

TYPE NO. 103-925 (NPN) — Line assembly, length to be specified, no flanges, hardware or connector. Weight: 10 oz./ft.



TYPE NO. 315-925 (NPN) — Hardware set, consists of 4 each, stainless steel bolts, nuts and lockwashers, 5/16" x 1 1/2" long. Weight: 3 1/2 oz.

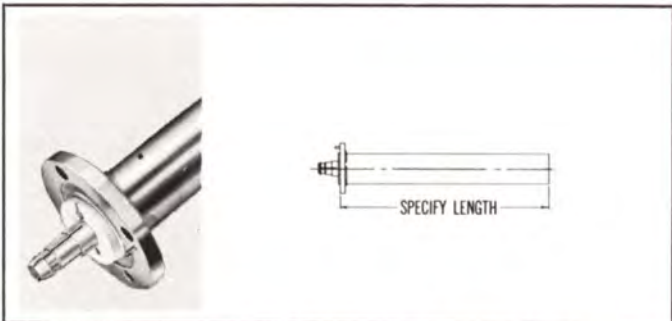

TYPE NO. 105-925 (NPN) — Line assembly, length to be specified, flanged one end. Includes anchor insulator-connector assembly, “O” ring and hardware. Weight: 12 oz. + 10 oz./ft.

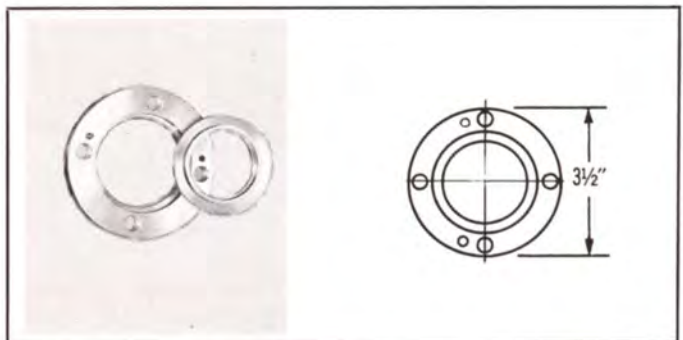

TYPE NO. 324-925 (NPN) — Flange, swivel, 6061 alloy. Weight: 4 1/2 oz.

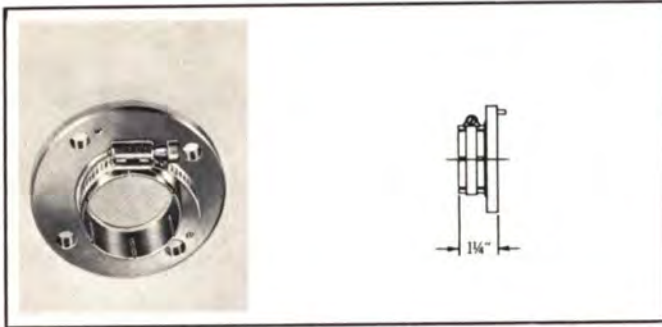

TYPE NO. 325-925 (NPN) — Adapter assembly, zinc plated, flanged to unflanged line, unpressurized, clamp type, for indoor use, includes hardware. Weight: 1 lb. 2 oz.

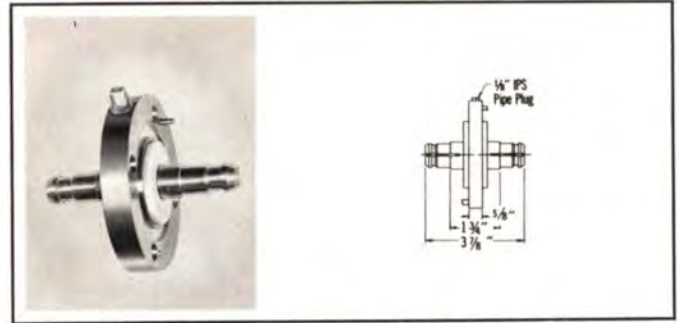

TYPE NO. 500-925 (NPN) — Gas barrier, zinc plated with "O" ring and 2" long hardware. Incorporates 1/8" IPS gas inlet port. Weight: 1 lb. 10 oz.

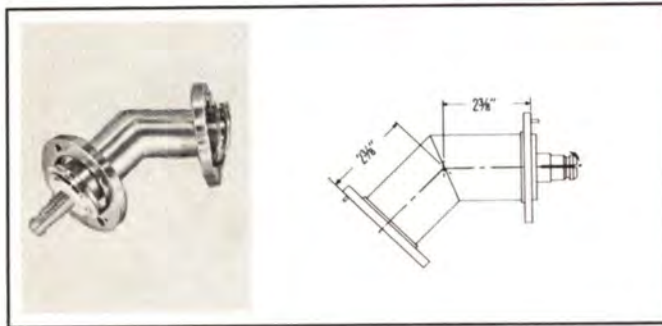

TYPE NO. 448-925 (NPN) — Elbow assembly, miter, 45 degree, male-female. Includes one affixed male anchor insulator, "O" ring and hardware. Weight: 1 lb. 4 oz.

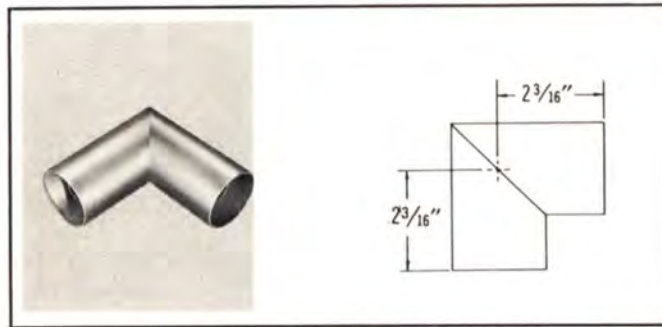

TYPE NO. 493-925 (NPN) — Elbow assembly, miter, 90 degree, female, no flanges, equal legs, unsupported inner conductor. Weight: 8 oz.

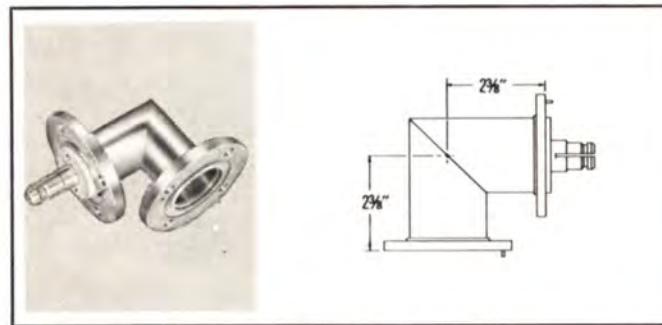

TYPE NO. 494-925 (NPN) — Elbow assembly, miter, 90 degree, male-female, swivel flanges. Includes one affixed male anchor insulator, "O" ring and hardware. Weight: 1 lb. 15 oz.

PRODELIN RIGID "800" 3 1/8" — 50 OHM ALUMINUM TRANSMISSION LINE AND ACCESSORIES Using EIA Flange Connector

3 1/8" — 50 OHM CHARACTERISTICS

Outer Conductor: Aluminum, Alloy 1100-H18, 3.125 O.D. x 3.027 I.D.

Inner Conductor: High Conductivity Copper Tube — 1.315 O.D. x 1.231 I.D.

Velocity — Percent: 99.7

60 cycle, Peak Test Voltage, KV: 19 lbs.

Insulator Supports: Teflon Pins, 60" spacing

Weight/20 ft. lgth.: 28 lbs. 10 oz.

Shipping Weight: 161 lbs.

No. Lines/Carton: 4

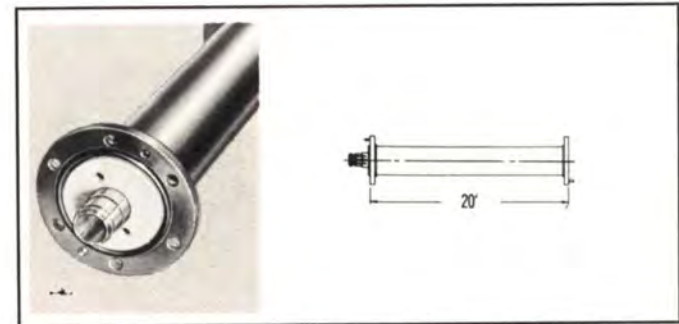

TYPE NO. 100-935 (NPN) — Line assembly, 20 ft. exact length, flanged both ends. Includes anchor insulator-connector assembly, "O" ring and hardware. Weight: 28 lbs. 10 oz.

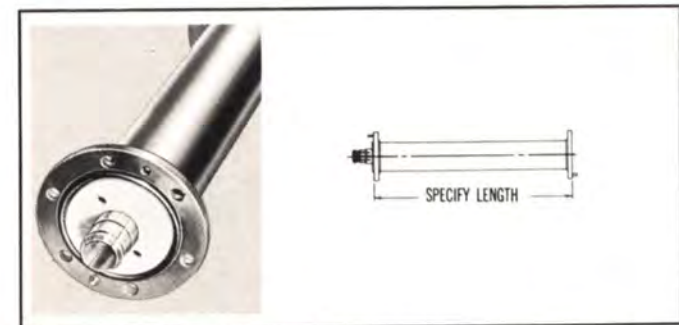

TYPE NO. 102-935 (NPN) — Line assembly, length to be specified, flanged both ends. Includes anchor insulator-connector assembly, "O" ring and hardware. Weight: 2 lbs. 10 oz. + 1 lb. 5 oz./ft.

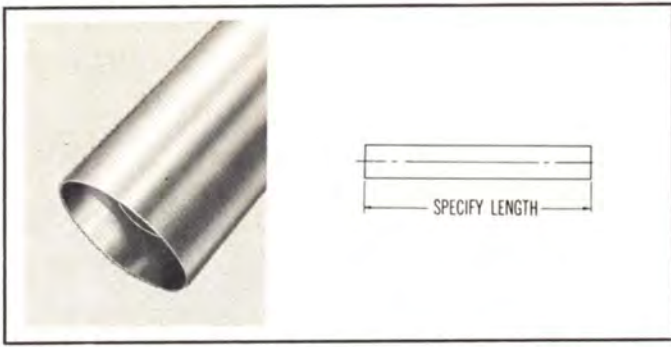

TYPE NO. 103-935 (NPN) — Line assembly, length to be specified, no flanges, hardware or connector. Weight: 1 lb. 5 oz./ft.

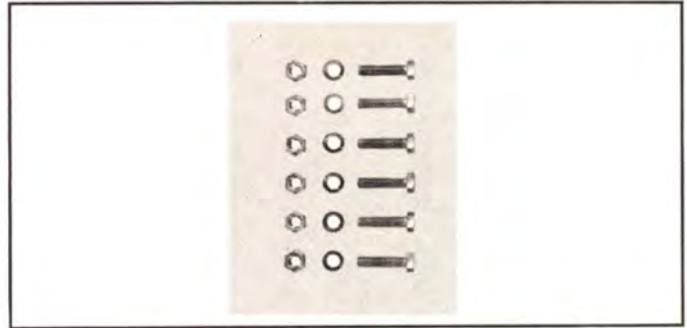

TYPE NO. 315-935 (NPN) — Hardware set, consists of 6 each stainless steel bolts, nuts and lockwashers, $\frac{3}{8}$ "-16 x $1\frac{1}{2}$ " lg. Weight: 8 $\frac{1}{2}$ oz.

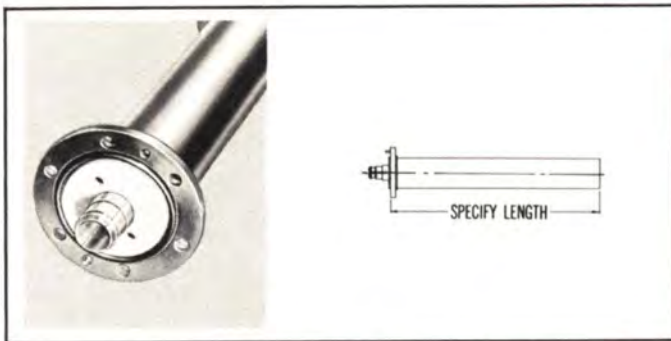

TYPE NO. 105-935 (NPN) — Line assembly, length to be specified, flanged one end. Includes anchor insulator-connector assembly, "O" ring and hardware. Weight: 2 lbs. + 1 lb. 5 oz./ft.

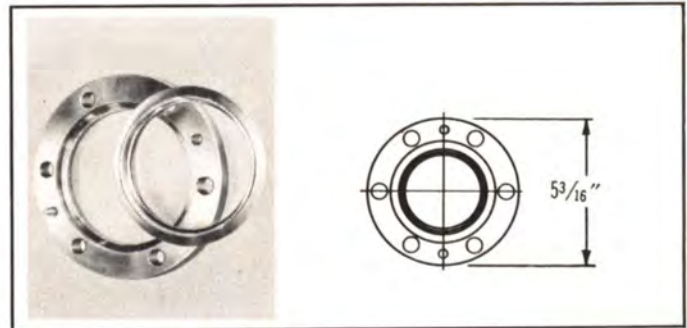

TYPE NO. 324-935 (NPN) — Flange, swivel, 6061 alloy. Weight: 8 $\frac{1}{2}$ oz.

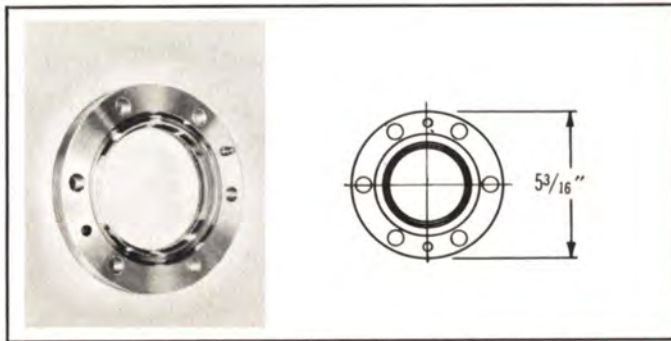

TYPE NO. 300-935 (NPN) — Flange, fixed, 6061 alloy. Weight: 8 $\frac{1}{2}$ oz.

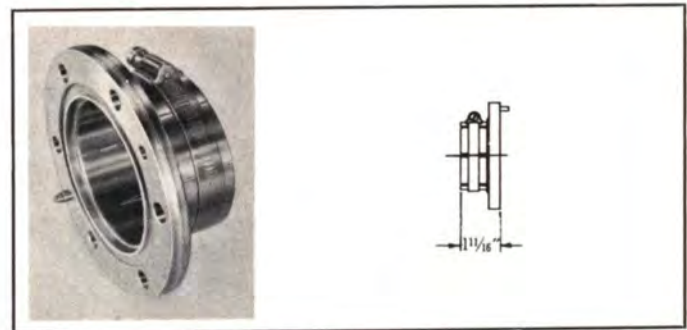

TYPE NO. 325-935 (NPN) — Adapter assembly, zinc plated, flanged to unflanged line, unpressurized, clamp type, for indoor use, includes hardware. Weight: 2 lbs. 8 oz.

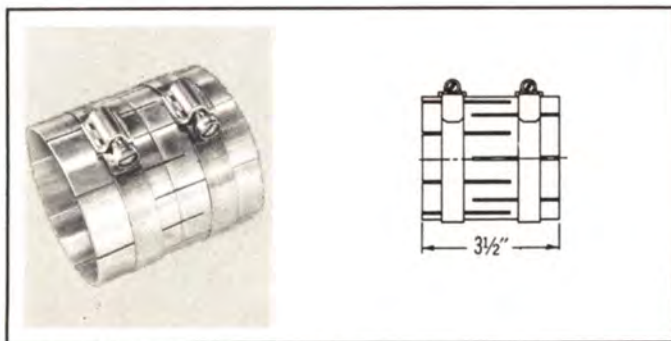

TYPE NO. 305-935 (NPN) — Coupling, straight, zinc plated, clamp type, unpressurized. Includes 2 tube clamps. No inner conductor-conector. Weight: 1 lb. 2 oz.

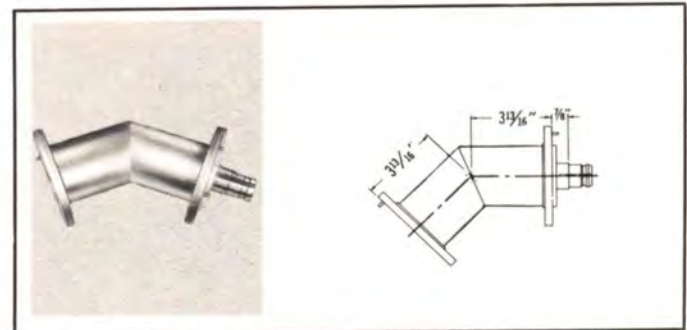

TYPE NO. 448-935 (NPN) — Elbow assembly, miter, 45 degree, swivel flanges. Includes one affixed male anchor insulator-connector, "O" ring and hardware. Weight: 3 $\frac{1}{2}$ lbs.

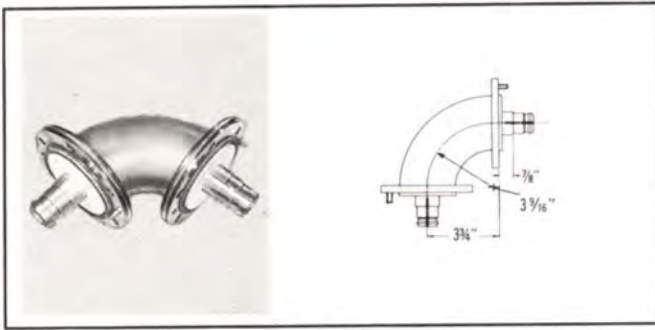

TYPE NO. 485-935 (NPN) — Elbow assembly, sweep, 90 degree, cast aluminum, swivel flanges. Includes affixed male anchor insulator-connectors, "O" ring and hardware for one end. Weight: 4 lbs. 5 oz.

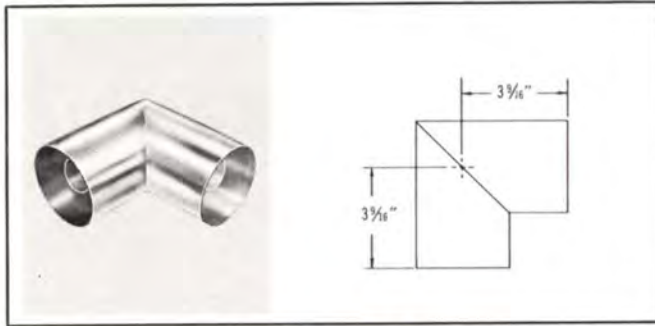

TYPE NO. 493-935 (NPN) — Elbow assembly, 90 degree, female, no flanges, equal legs. Unsupported inner conductor. Weight: 3 lbs.

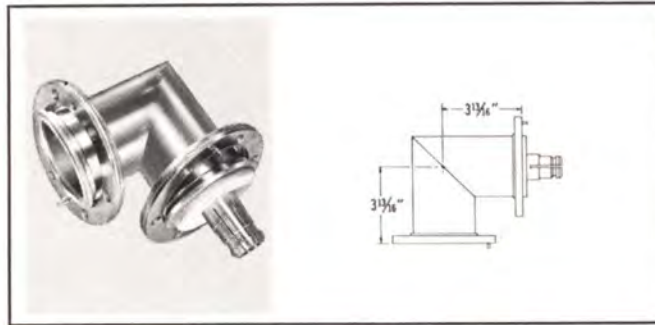

TYPE NO. 494-935 (NPN) — Elbow assembly, miter, 90 degree, male-female, swivel flanges. Includes one affixed anchor insulator-connector, "O" ring and hardware. Weight: 4 lbs. 9 oz.

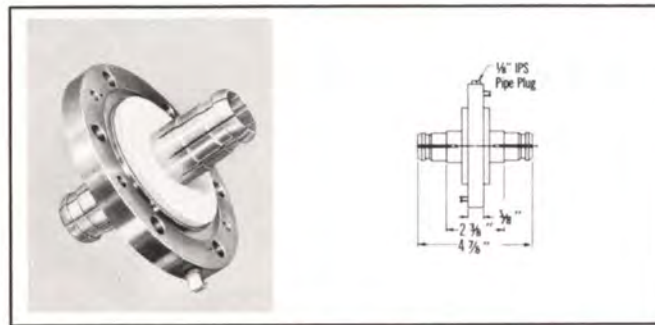

TYPE NO. 500-935 (NPN) — Gas barrier, zinc plated, with "O" ring and 2 1/4" long hardware. Incorporates 1/8" IPS gas inlet port. Weight: 3 lbs. 13 oz.

PRODELIN RIGID "800" 1 5/8" — 50 OHM

ALUMINUM TRANSMISSION LINE AND ACCESSORIES Using the Spir-O-lok Connector

1 5/8"—50 OHM CHARACTERISTICS

Outer Conductor: Aluminum, Alloy 1100-H18, 1.625 O.D. x 1.527 I.D.

Inner Conductor: High Conductivity Copper Tube .664 O.D. x .588 I.D.

Velocity — Percent: 99.7

60 cycle, Peak Test Voltage, KV: 11

Insulator Supports: Teflon Pins, 30" spacing

Weight/20 ft. lgth.: 12 1/2 lbs.

Shipping Weight: 155 lbs.

No. Lines/Cartron: 8

Cartron Size: 12" x 12" x 243"

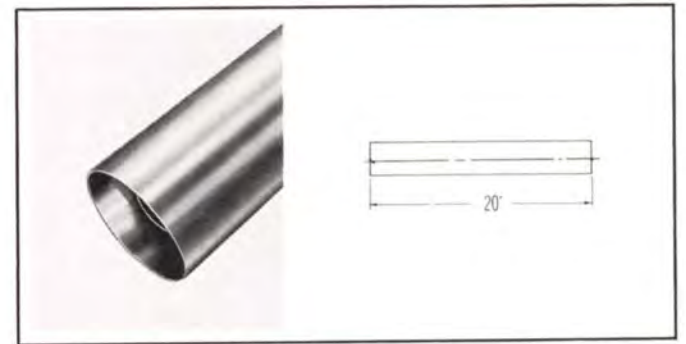

TYPE NO. 101-925 (NPN) — Coaxial line assembly, 20 ft. exact length, no flange. Weight: 12 1/2 lbs.

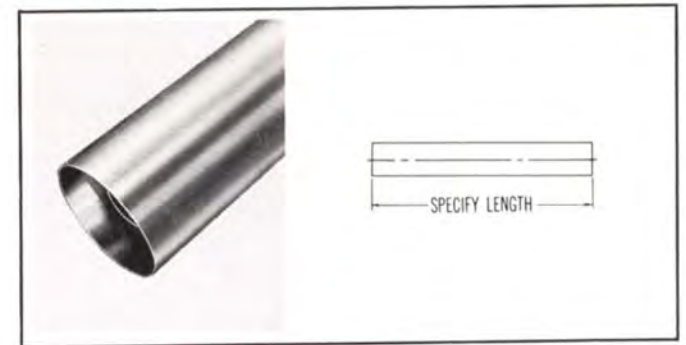

TYPE NO. 103-925 (NPN) — Coaxial line assembly, no flanges, length to be specified. Weight: 10 oz./ ft.

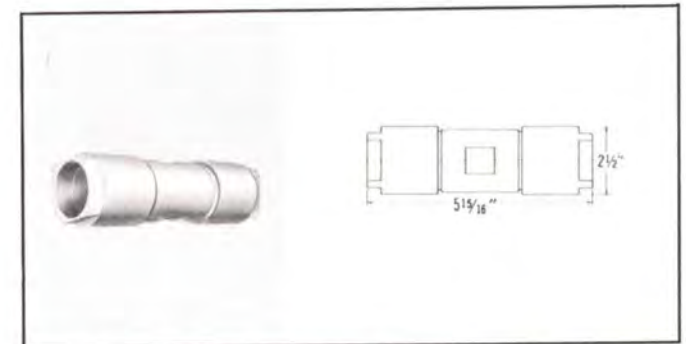

TYPE NO. 79-1025 (NPN) — Coupling assembly, includes anchor insulator-connector. Weight: 1 lb. 10 oz.

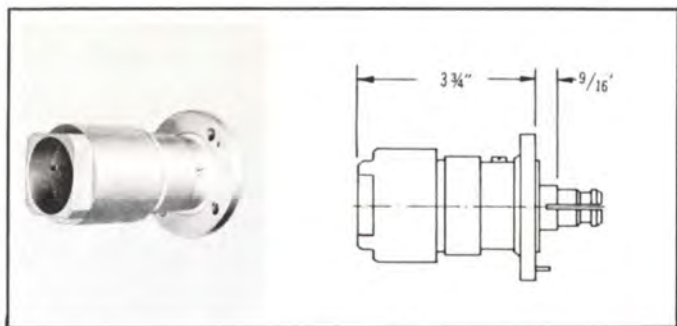

TYPE NO. 81-1025 (NPN) — Adapter assembly, 1 5/8" rigid to 1 5/8" EIA male, includes anchor insulator. Weight: 1 lb. 8 oz.

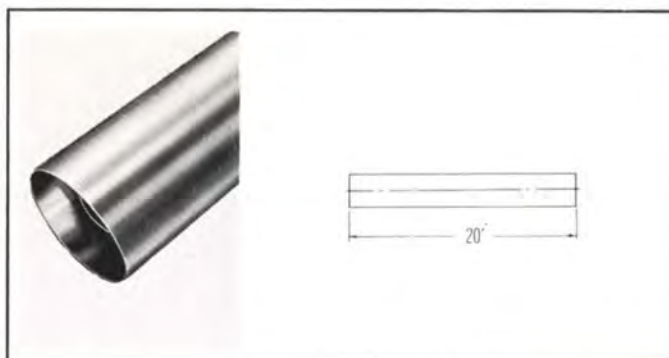

TYPE NO. 101-935 (NPN) — Coaxial line assembly, 20 ft. exact length, no flanges. Weight: 25 lbs.

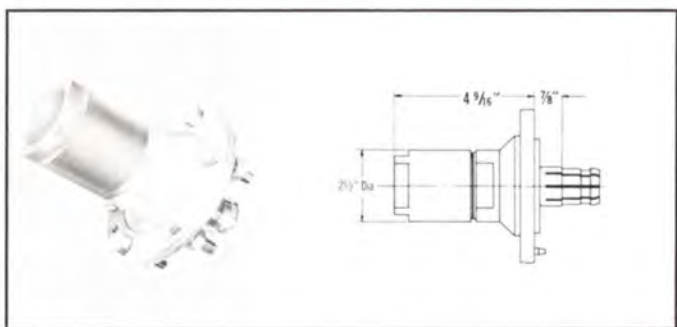

TYPE NO. 82-1025 (NPN) — Adapter assembly, 1 5/8" to 3 1/8" EIA male, includes anchor insulator-connector. Weight: 2 lbs. 6 oz.



TYPE NO. 103-935 (NPN) — Coaxial line assembly, no flanges, length to be specified. Weight: 1 lb. 4 oz./ft.

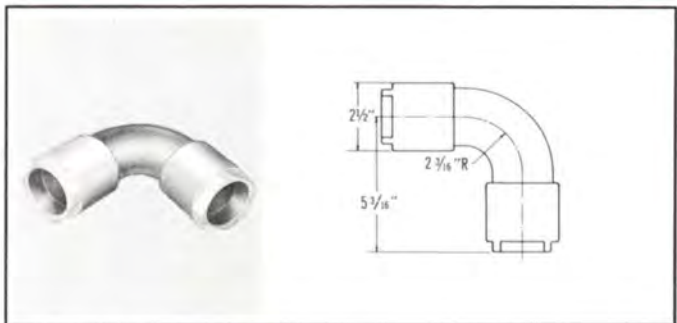

TYPE NO. 485-1025 (NPN) — Elbow assembly, sweep, 90° aluminum with Spir-O-lok connector. Weight: 3 1/2 lbs.

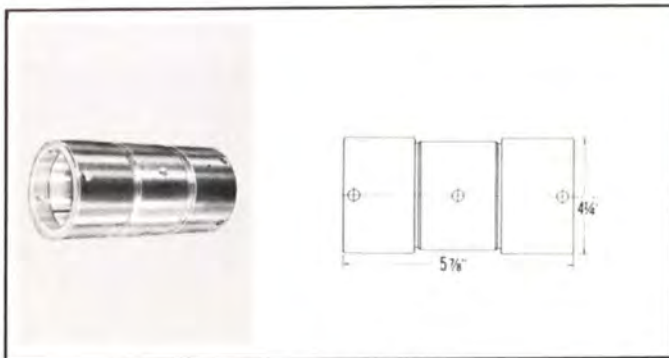

TYPE NO. 79-1035 (NPN) — Coupling assembly, includes anchor insulator-connector. Weight: 3 3/4 lbs.

PRODELIN RIGID "800" 3 1/8" — 50 OHM

ALUMINUM TRANSMISSION LINE AND ACCESSORIES Using the Spir-O-lok Connector

3 1/8" — 50 OHM CHARACTERISTICS

Outer Conductor: Aluminum, Alloy 1100-H18, 3.125 O.D. x 3.027 I.D.

Inner Conductor: High Conductivity Copper Tube 1.315 O.D. x 1.231 I.D.

Velocity — Percent: 99.7

60 cycle, Peak Test Voltage, KV: 19

Insulator Supports: Teflon Pins, 60" spacing

Weight/20 ft. lgth.: 25 lbs.

Shipping Weight: 147 lbs.

No. Lines/Cartron: 4

Cartron Size: 12" x 12" x 243"

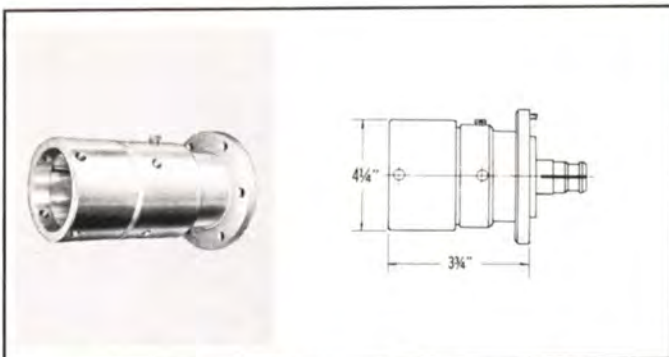

TYPE NO. 81-1035 (NPN) — Adapter Assembly, 3 1/8" rigid to 3 1/8" EIA, male, includes anchor insulator-connector. Weight: 3 lbs. 5 oz.

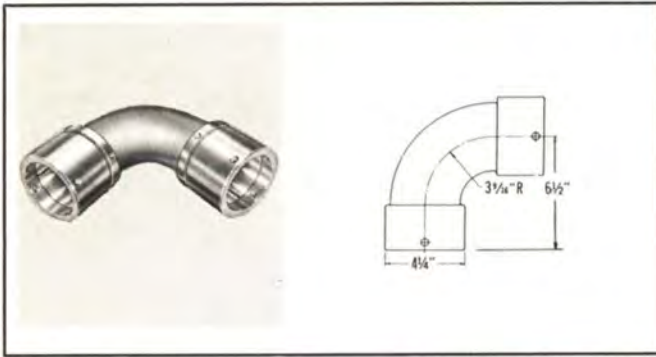

TYPE NO. 485-1035 (NPN) — Elbow assembly, sweep, 90° cast aluminum with Spir-O-lok connectors, both male ends. Weight: 7 lbs.

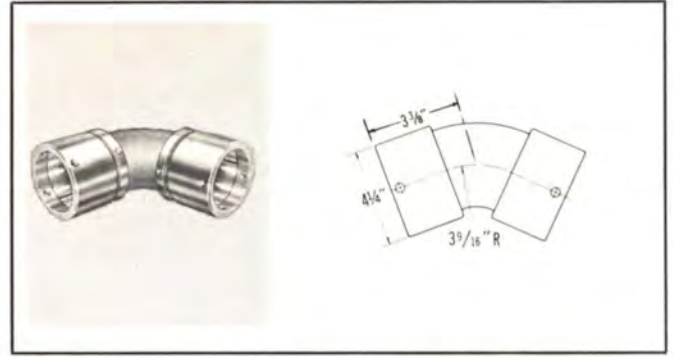

TYPE NO. 490-1035 (NPN) — Elbow assembly, sweep, 45° cast aluminum with Spir-O-lok connectors, both male ends. Weight: 5 lbs. 3 1/2 oz.

SPIR-O-LOK CONNECTOR FOR ALUMINUM LINE

The Spir-O-lok connector was first introduced with Spir-O-line coaxial cable and has now proved to be the simplest, quickest and most positive and foolproof connector available for coaxial cable installations designed to date.

The design of this type connector, which does not require soldering or brazing or any special preparation to the end of the transmission line, permits the assembly of transmission line sections with plain ends in a very economical manner with the use of small hand tools.

A cross section of the Spir-O-lok grip is illustrated below.

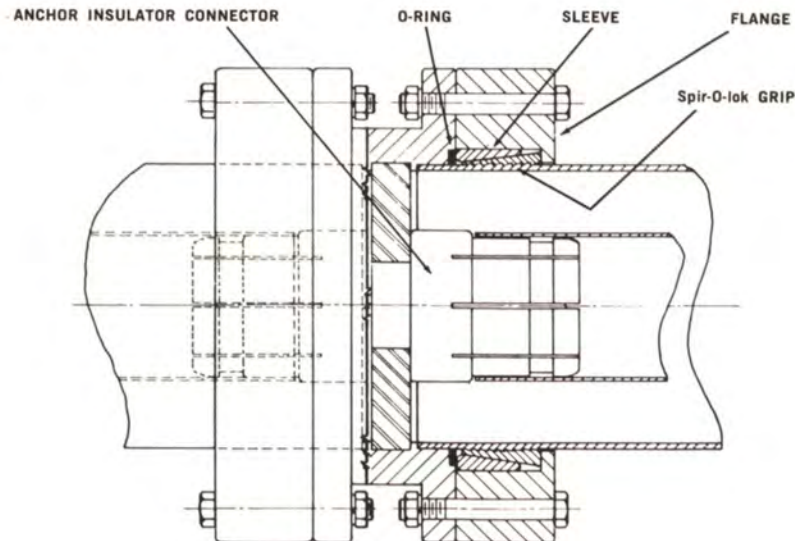
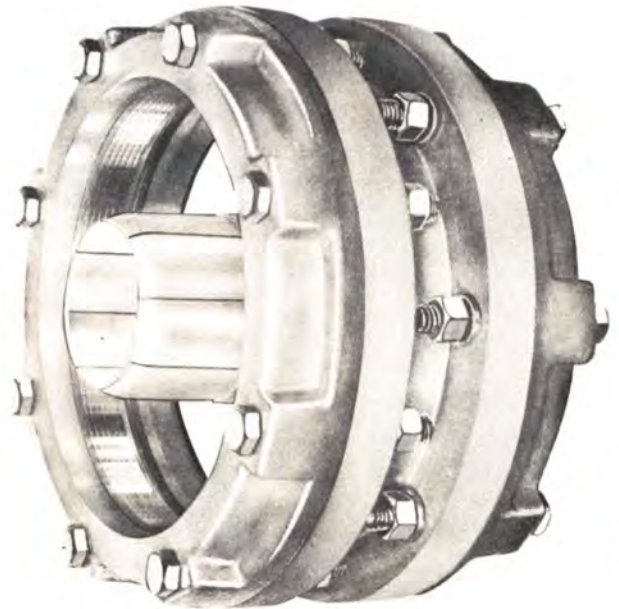

**PRODELIN RIGID "800" 1⁵/₈"
SUPPORTING HARDWARE**

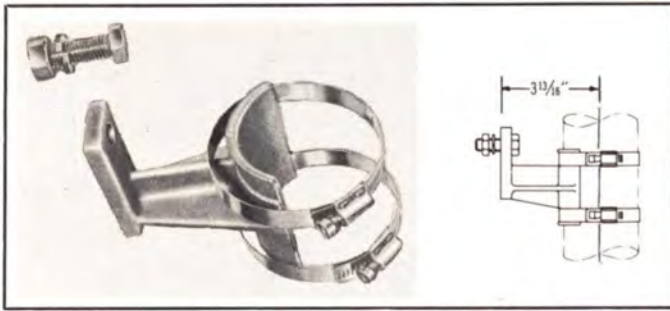

TYPE NO. 201-825 (NPN) — Hanger, fixed, direct attached, single line. Mounts through $\frac{1}{8}$ " dia. hole. Line clamp and hardware supplied. Weight: 1 lb. 4 oz.

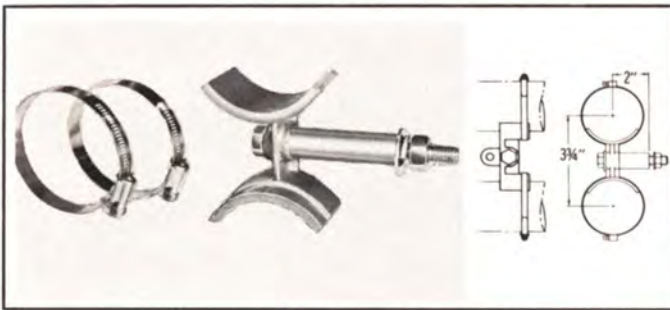

TYPE NO. 202-825 (NPN) — Hanger, fixed, direct attached, dual line. Mounts through $\frac{1}{8}$ " dia. hole. Line clamps and hardware supplied. Weight: 1 lb. 6 oz.

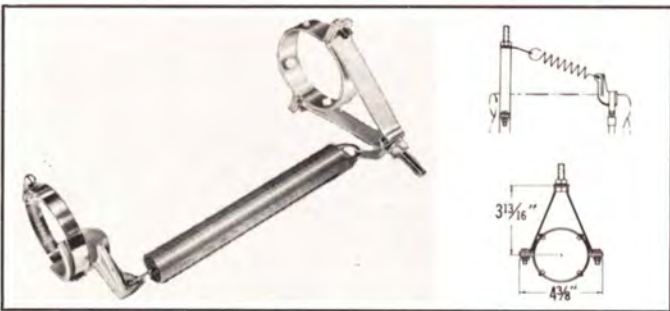

TYPE NO. 203-825 (NPN) — Hanger, spring suspension, direct attached, single line. Mounts through $\frac{1}{8}$ " dia. hole. Line clamps and hardware supplied. Weight: 2 $\frac{1}{2}$ lbs.

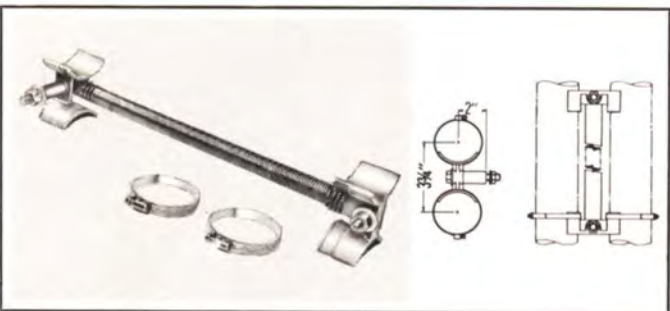

TYPE NO. 204-825 (NPN) — Hanger, spring suspension, direct attached, dual line. Mounts through $\frac{1}{8}$ " dia. hole. Line clamps and hardware supplied. Weight: 3 lbs.

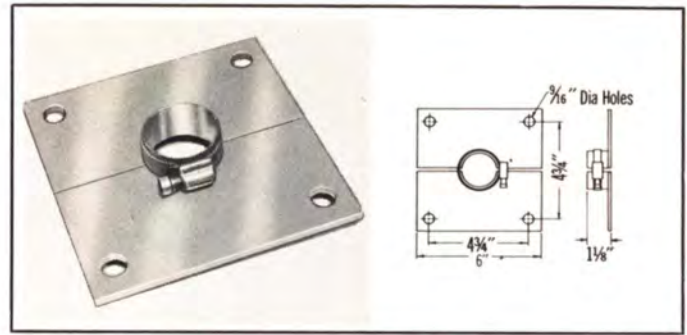

TYPE NO. 205-825 (NPN) — Anchor plate for anchoring single line at point of entry through a wall. One anchor required on each side of wall. Mounting bolts not supplied. Weight: 2 lbs. 10 oz.

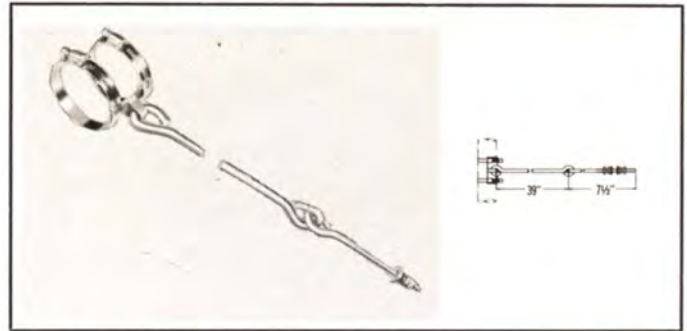

TYPE NO. 208-825 (NPN) — Lateral brace for securing transmission line at base of tower. Complete with clamps. Weight: 2 lbs. 5 oz.

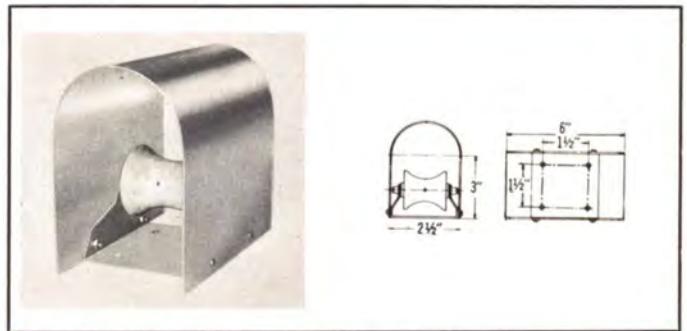

TYPE NO. 209-825 (NPN) — Roller assembly consisting of roller, bracket and hood for outdoor horizontal transmission line runs. Weight: 1 lb. 5 oz.

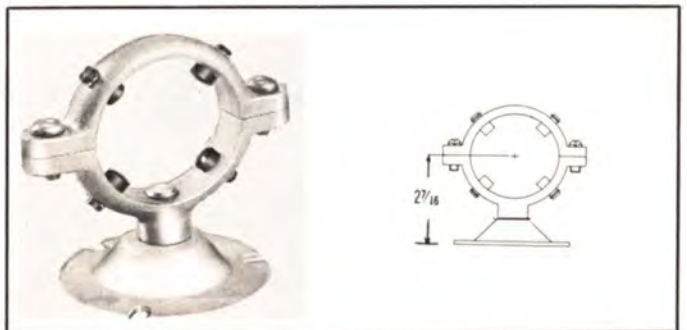

TYPE NO. 211-825 (NPN) — Hanger, slip type, flange mount supports transmission indoors or outdoors. Permits expansion. Weight: 14 $\frac{1}{2}$ oz.

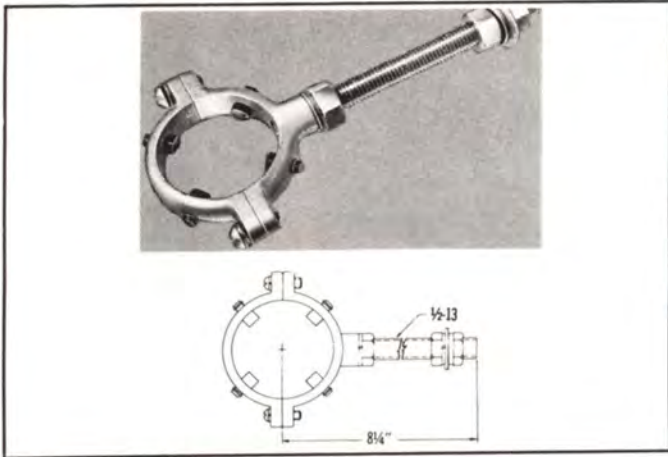

TYPE NO. 212-825 (NPN) — Hanger, slip type, 7" stud mount ($\frac{1}{2}$ "-13 thread. Weight: 1 lb. 3 oz.

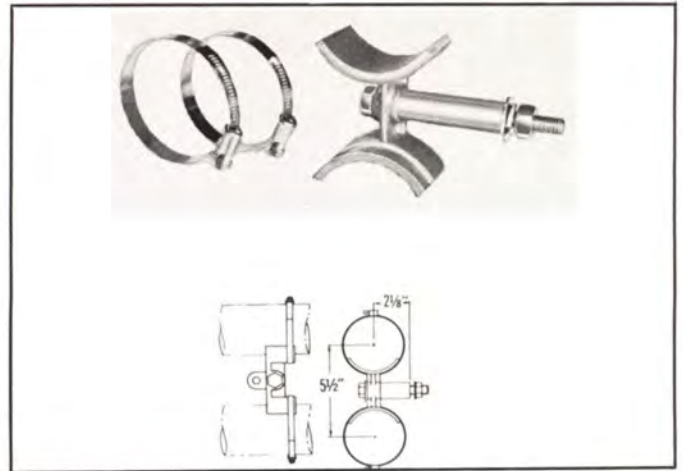

TYPE NO. 202-835 (NPN) — Hanger, fixed, direct attached, dual line. Mounts through $\frac{1}{8}$ " dia. hole. Line clamps and hardware supplied. Weight: 2 lbs. 2 oz.

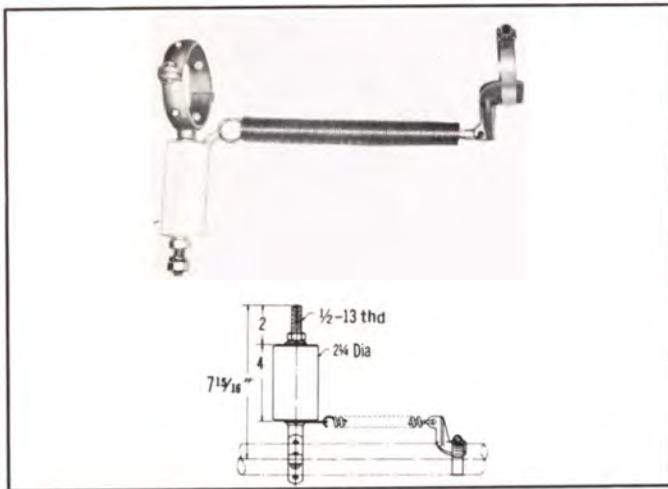

TYPE NO. 213-825 (NPN) — Hanger, insulated, direct attached. Mounts through $\frac{1}{8}$ " dia. hole. Hardware supplied. Weight: 3 lbs. 11 oz.

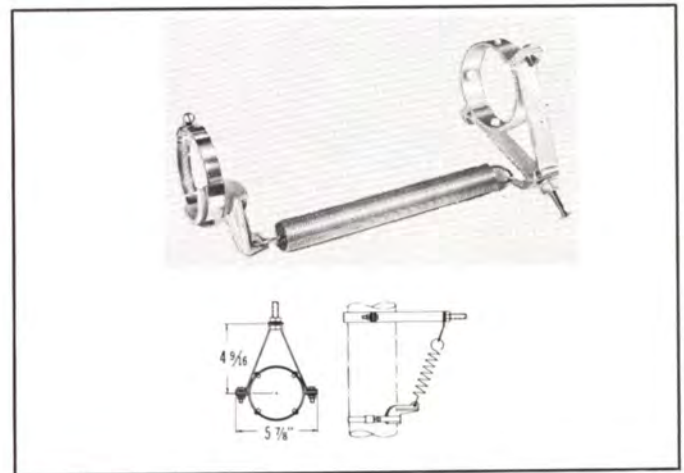

TYPE NO. 203-835 (NPN) — Hanger, spring suspension, direct attached, single line. Mounts through $\frac{1}{8}$ " dia. hole. Line clamps and hardware supplied. Weight: 2 lbs. 12 oz.

PRODELIN RIGID "800" $3\frac{1}{8}$ " SUPPORTING HARDWARE

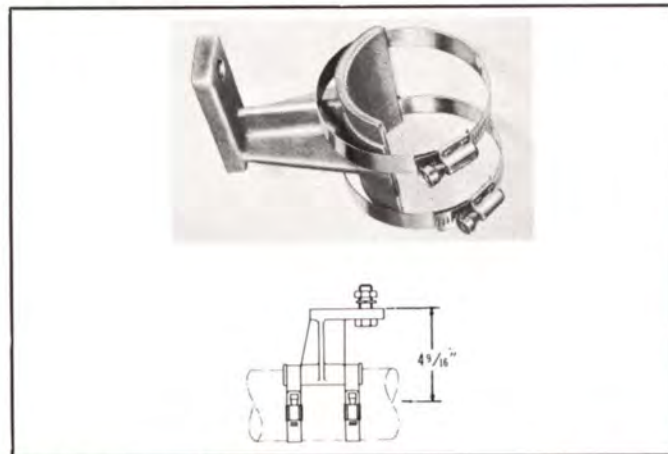

TYPE NO. 201-835 (NPN) — Hanger, fixed, direct attached, single line. Mounts through $\frac{1}{8}$ " dia. hole. Line clamp and hardware supplied. Weight: 2 lbs. 4 oz.

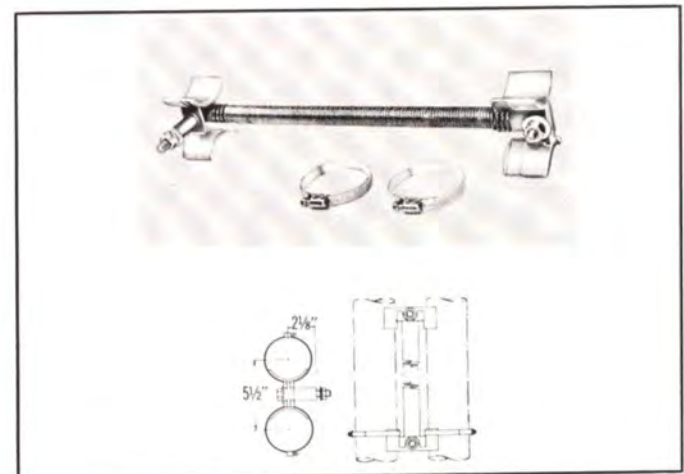

TYPE NO. 204-835 (NPN) — Hanger, spring suspension, direct attached, dual line. Mounts through $\frac{1}{8}$ " dia. hole. Line clamps and hardware supplied. Weight: 4 lbs. 12 oz.

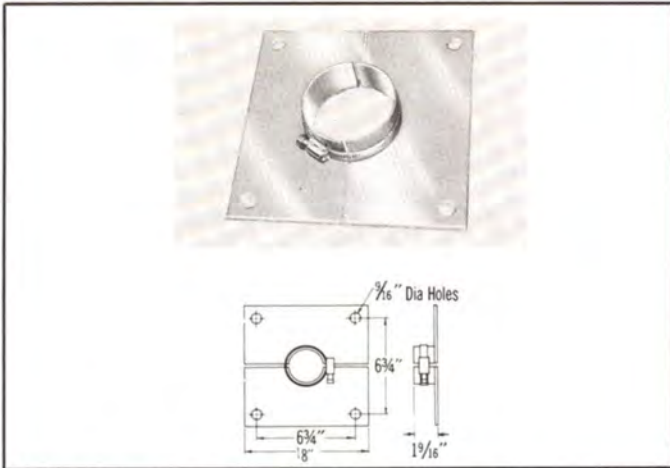

TYPE NO. 205-835 (NPN) — Anchor plate for anchoring single line at point of entry through a wall. One anchor required on each side of wall. Mounting bolts not supplied. Weight: 2 lbs. 12 oz.



TYPE NO. 211-835 (NPN) — Hanger, slip type, flange mount supports transmission indoors or outdoors. Permits expansion. Weight: 1 1/2 lbs.

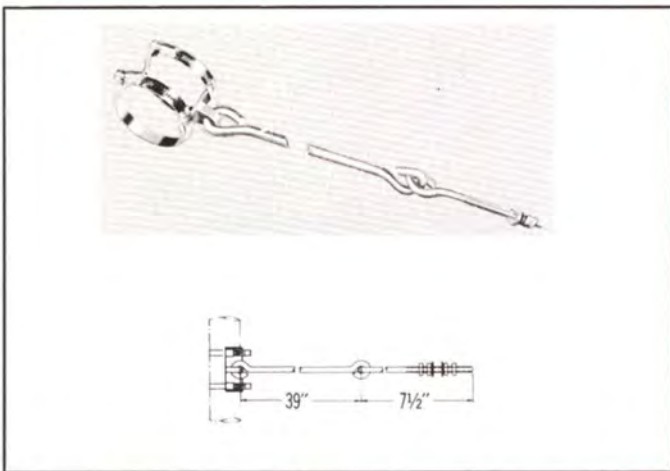

TYPE NO. 208-835 (NPN) — Lateral brace for securing transmission line at base of tower. Complete with clamps. Weight: 2 lbs. 5 oz.

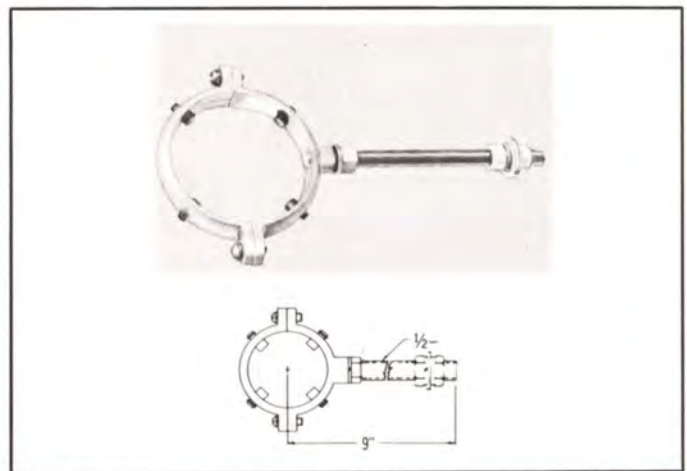

TYPE NO. 212-835 (NPN) — Hanger, slip type, 7" stud mount (1/2"-13 thread). Weight: 1 lb. 12 oz.

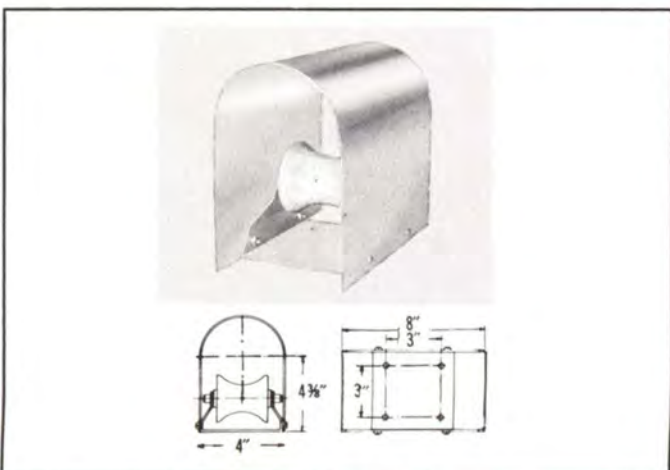

TYPE NO. 209-835 (NPN) — Roller assembly consisting of roller, bracket and hood for outdoor horizontal transmission line runs. Weight: 1 lb. 3 oz.

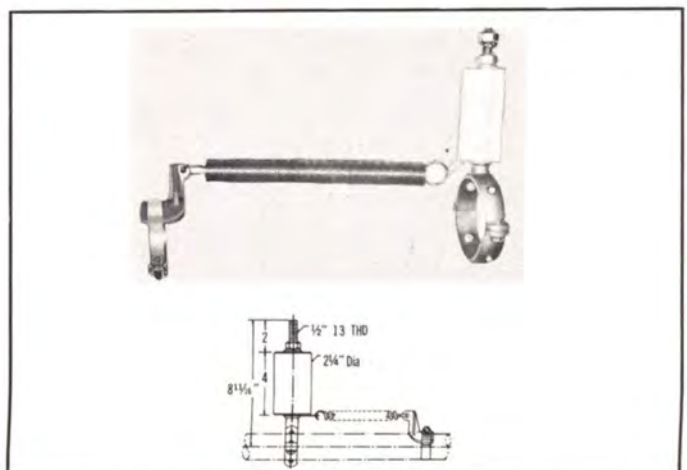

TYPE NO. 213-835 (NPN) — Hanger, insulated, direct attached. Mounts through 1/8" dia. hole. Hardware supplied. Weight: 5 lbs.

IMPEDANCE

The characteristic impedance of a coaxial transmission line of infinite conductivity is given by

$$Z_0 = \sqrt{\epsilon_{eff}} \frac{138}{d} \log_{10} \frac{D}{d}$$

Where Z_0 = Characteristic Impedance in ohms
 ϵ_{eff} = Effective dielectric constant
 D = I.D. of the outer conductor in inches
 d = O.D. of the inner conductor in inches

Where ϵ_{eff} the effective dielectric constant for disc supported line is determined by

$$\epsilon_{eff} = 1 + \frac{NT}{S} (\epsilon - 1)^*$$

*Rigid "800" is a pin supported line. Each pin is essentially transparent, therefore only the anchor insulators need be considered in this calculation.

Where N = Number of discs
 T = Thickness of discs in inches
 S = Total line length in inches
 ϵ = Dielectric constant of disc

The capacitance of this line is

$$C = \frac{7.354 \epsilon_{eff}}{\log_{10} \frac{D}{d}} 10^{-12} \text{ farads/foot}$$

The inductance is $L = 0.1405 \log_{10} \left(\frac{D}{d} \right) 10^{-6}$ henries/foot

These formulae are close approximations for normal calculations at VHF or higher frequencies. When working at lower frequencies the finite conductivity of the materials should be considered.

IMPEDANCE MATCHING

A simple technique for transforming antenna impedance to transmission line impedance is by use of a quarter-wave length transformer. The transformer is a section of transmission line whose characteristic impedance can be determined by the formula

$$Z_0 = \sqrt{Z_i Z_o}$$

Where Z_i = Input impedance in ohms
 Z_o = Output impedance in ohms

The length of this section must be $\frac{\lambda_i}{4}$ in the coaxial transmission line at the operating frequency. This is given by

$$\frac{\lambda_i}{4} = \frac{V\lambda}{400}$$

Where velocity, V in percent is determined by

$$V = \sqrt{\epsilon_{eff}} \text{ and } \lambda = \frac{1180}{f_o}$$

Where λ = Wavelength in free space in inches
 λ_i = Wavelength in the transmission line in inches

f_o = Operating frequency in Megacycles/second

VSWR AS A FUNCTION OF ATTENUATION

This curve shows the increase in power loss given in DB as a function of VSWR above the normal attenuation of the line. It will be noted that this effect is generally quite small for normal conditions.

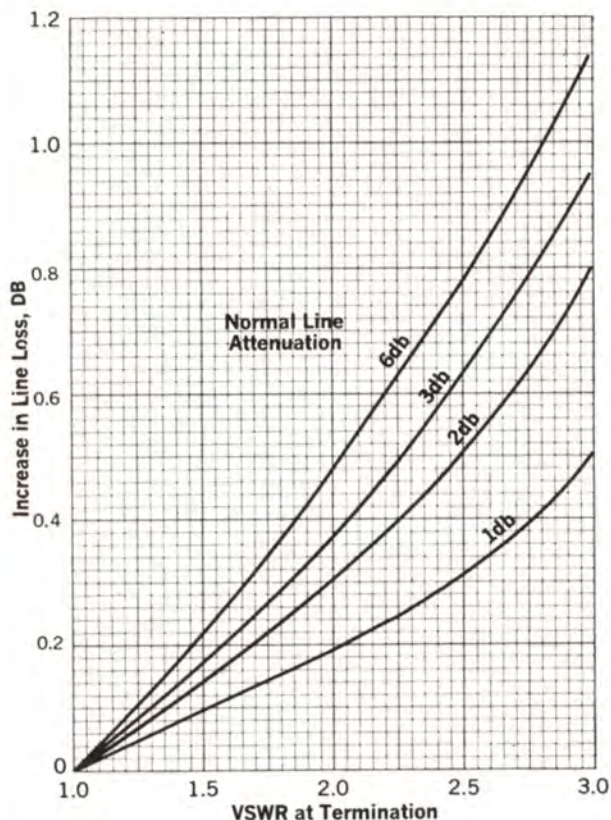

ATTENUATION AS A FUNCTION OF VSWR

This curve shows the reduction of VSWR at the input of the line as a function of VSWR at the load for given line losses.

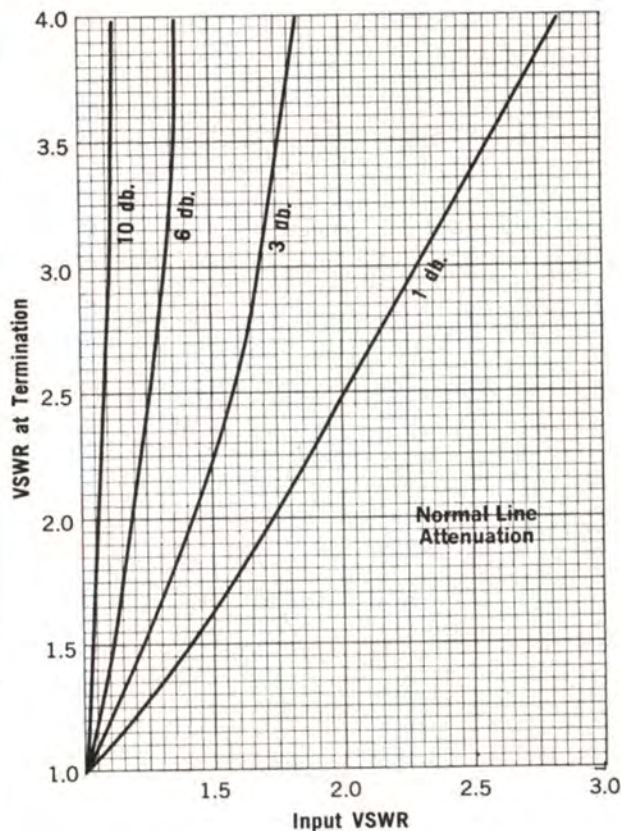

AVERAGE POWER RATING

The average power rating pertains to the temperature rise of the inner conductor. An inner conductor temperature of 100°C is considered safe for Teflon supported copper center conductors. The average power rating with the above mentioned center conductor temperature and a 40 degree centigrade ambient temperature can be calculated from the following:

$$P_{av} = \frac{16.4 \delta D K}{(DF) \alpha (DB)} (VSWR)$$

Where P_{av} = Average power in kilowatts limited by center conductor temperature.

δ = Emissivity coefficient in watts/in²

D = OD of the transmission line

DF = Duty Factor

$VSWR$ = Standing wave ratio

$\alpha (DB)$ = Attenuation in decibel per 100 feet

K = Derating factor for ambient temperature from curve on this page.

Emissivity coefficient is given in the curve on this page for both copper and aluminum outer conductors. (DB) takes into consideration the increase in losses due to the higher center conductor temperature.

PEAK POWER RATING

The peak power ratings shown below are nearly constant with frequency and are based on a VSWR of unity and one atmosphere of dry air pressure at sea level and 40°C ambient temperature. No factor of safety has been applied to these values. Rigid "800" is fabricated to give maximum power ratings with little or no degradation in VSWR. The asterisks indicate measured values.

RIGID "800"

LINE SIZE	PEAK POWER RATING IN MEGAWATTS
7/8—50 ohm	0.15 Megawatts*
1 1/8—50 ohm	0.50 Megawatts*
3 1/8—50 ohm	2.0 Megawatts*
4 1/8—50 ohm	3.5 Megawatts
6 1/8—50 ohm	7.8 Megawatts
6 1/8—50 ohm	5.1 Megawatts
9—50 ohm	17.0 Megawatts

Peak Power in megawatts can be calculated from the following

$$P_v = \frac{16Kd^2 \log_{10} \left(\frac{D}{d} \right) (P_i)^2 (E_d)^2}{S^2 \cdot VSWR} \left(\frac{P}{P} \right)^2 (E_d)^2$$

Where P_v = Peak power in megawatts limited by flashover.

E_d = Dielectric strength of pressurizing medium

S = Safety factor, normally taken as 2

P = Absolute atmospheric pressure in PSI

P_i = Absolute internal line pressure in PSI

The curve on this page illustrates the effect of altitude on peak power rating for an unpressurized line.

It can be seen from the above formula that higher peak power ratings can be achieved by pressurizing with gases having a dielectric strength greater than air. In many situations increasing the internal pressure (up to 50 Psig) may be sufficient. A combination of greater pressure and higher dielectric strength may yield values 4 to 6 times those normally obtained.

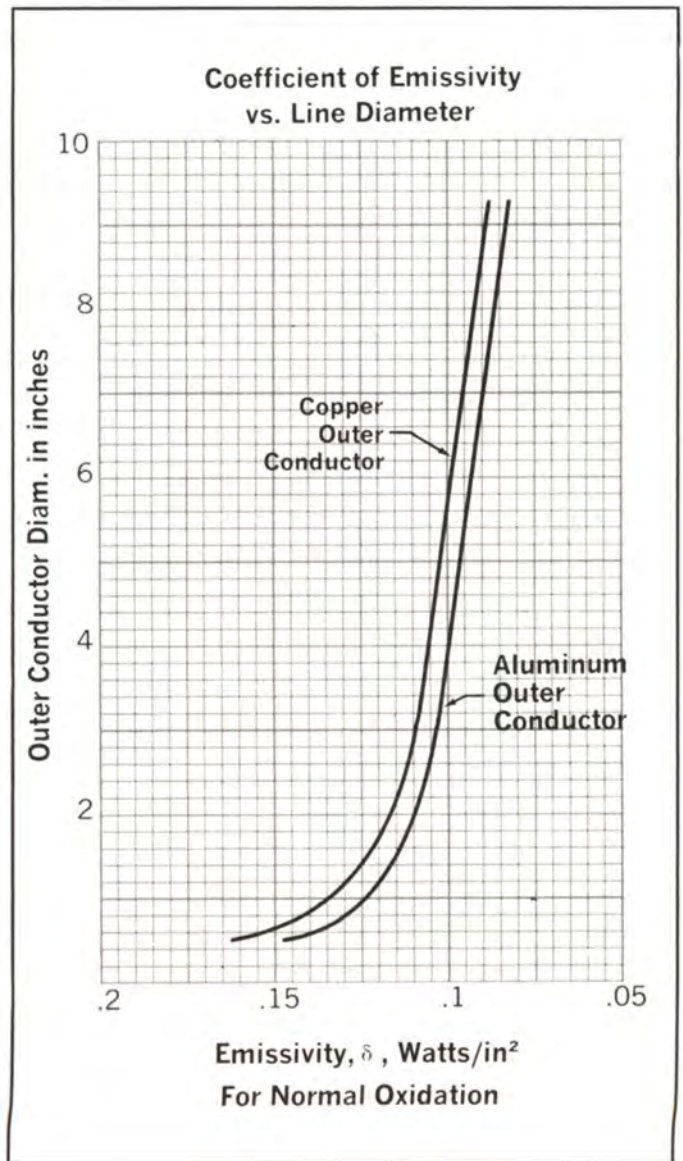
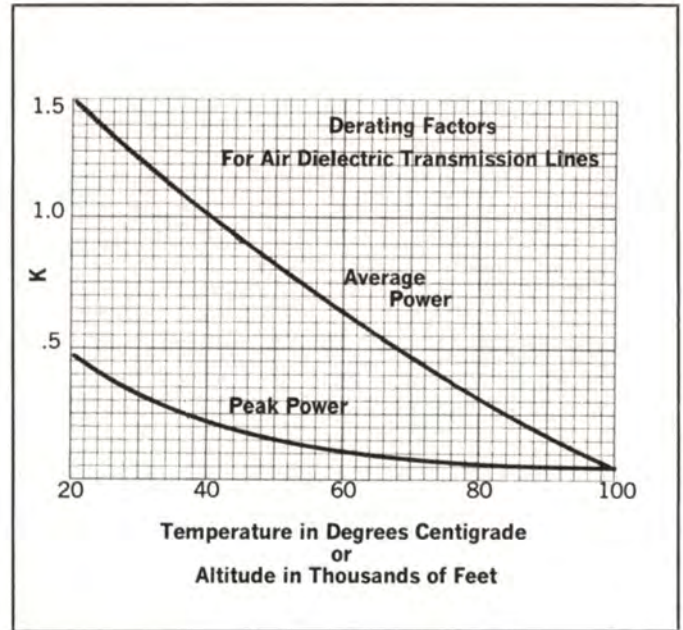

ATTENUATION VS. FREQUENCY
RIGID "800" COPPER TRANSMISSION LINE

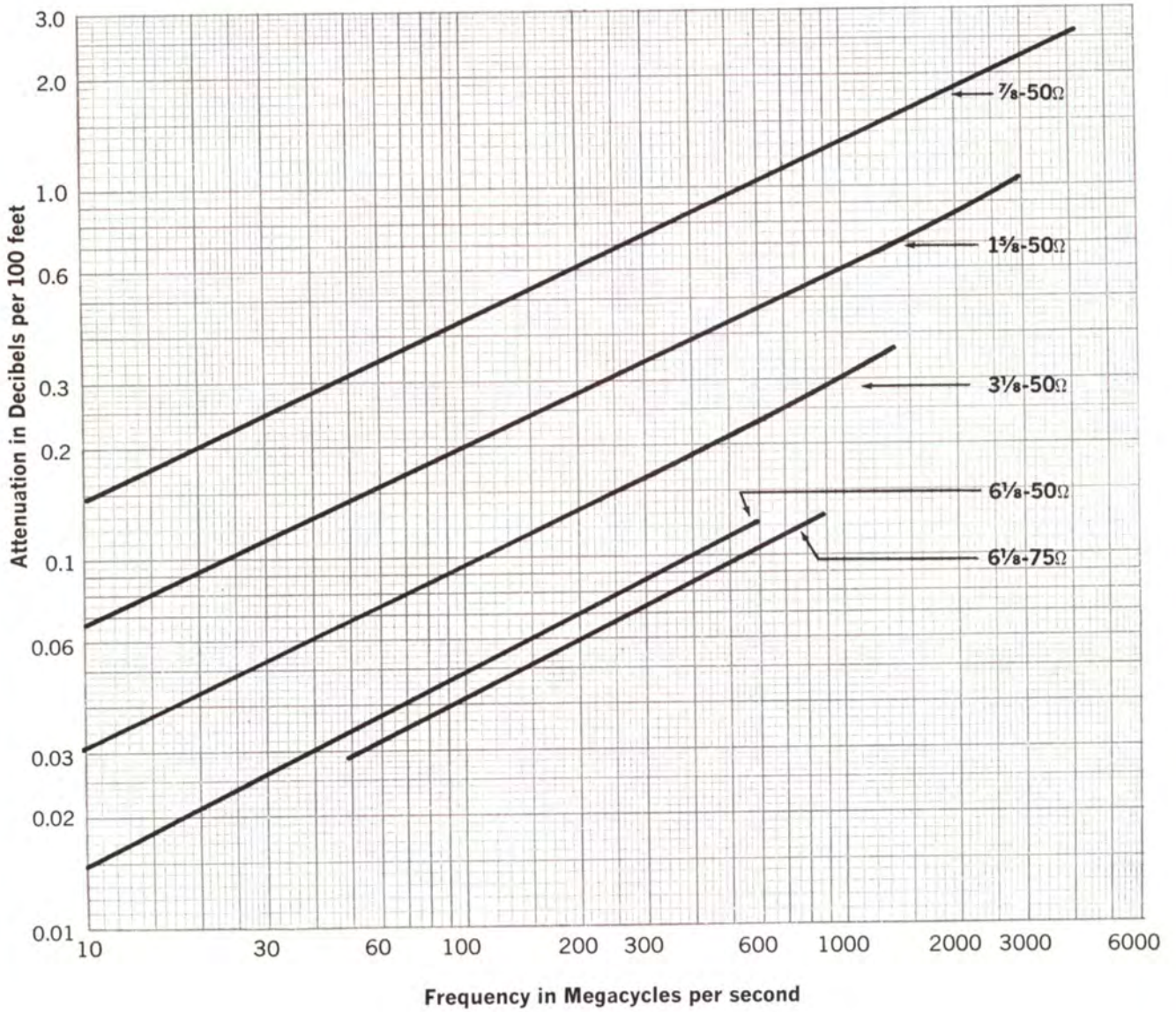

**AVERAGE POWER VS. FREQUENCY AT 40°C. AMBIENT TEMPERATURE
RIGID "800" COPPER TRANSMISSION LINE**

Based on Unity VSWR

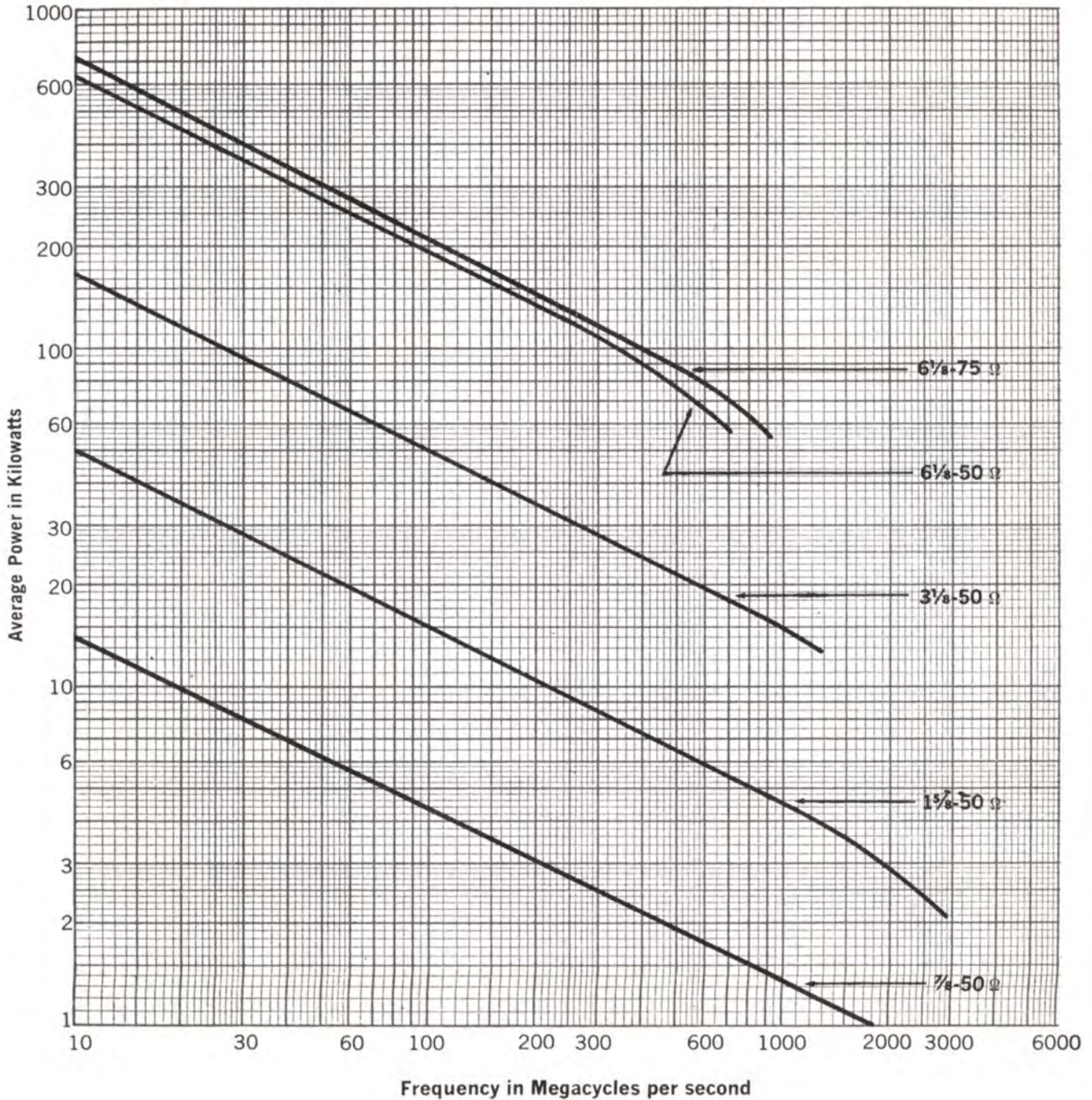

POWER RATING FOR AM-FM RIGID "800" COPPER TRANSMISSION LINE

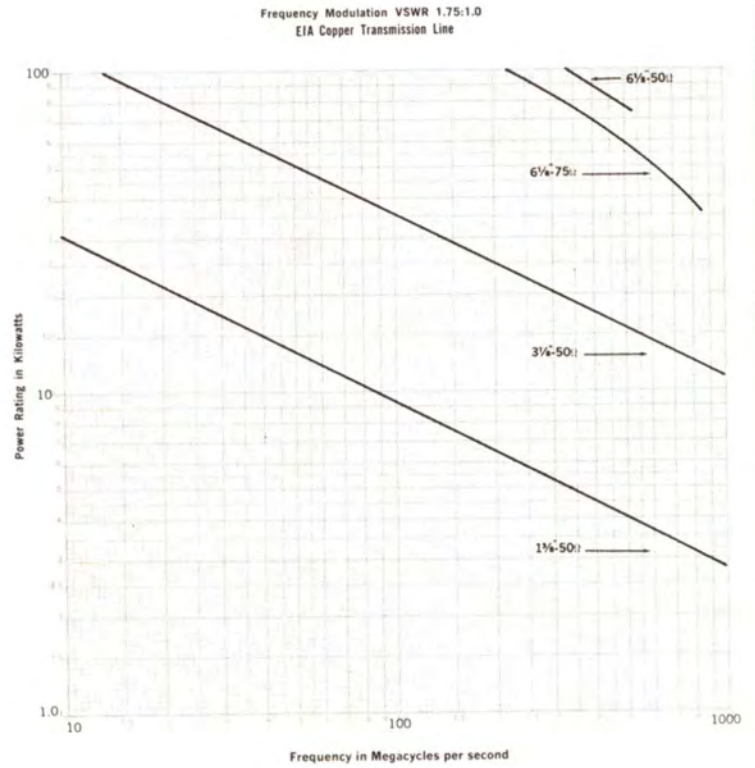
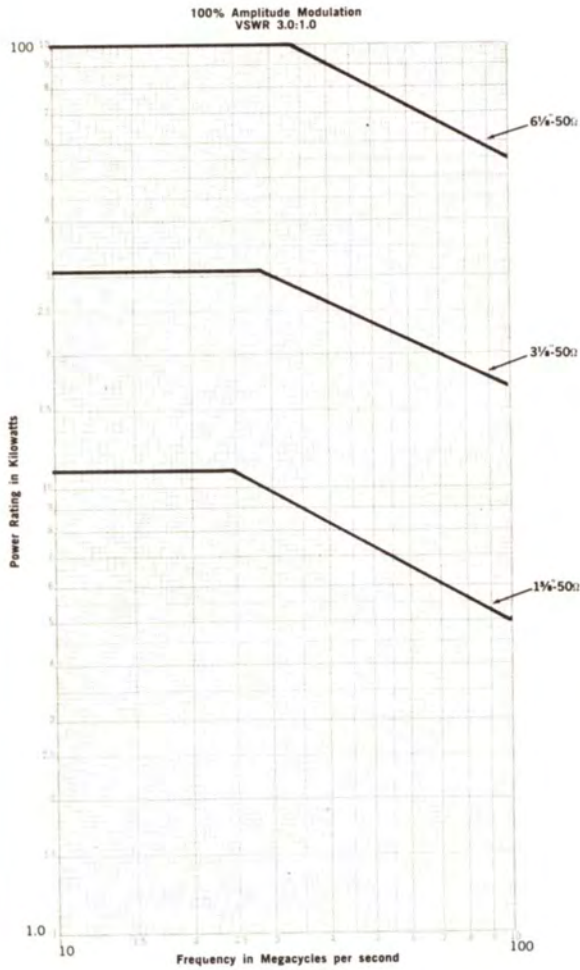

ATTENUATION VS. FREQUENCY
RIGID "800" ALUMINUM TRANSMISSION LINE

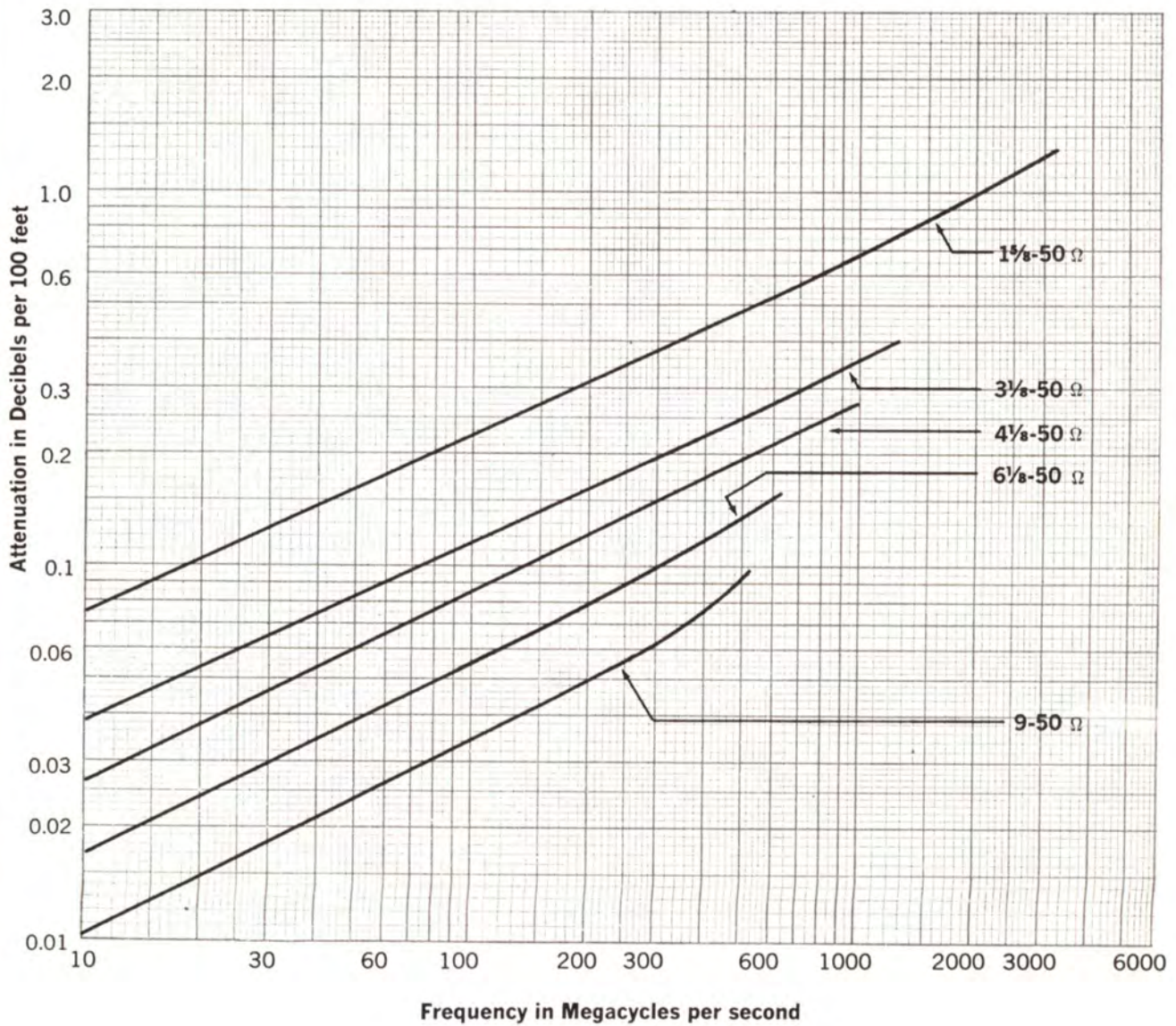

AVERAGE POWER VS. FREQUENCY AT 40°C. AMBIENT TEMPERATURE RIGID "800" ALUMINUM TRANSMISSION LINE

Based on Unity VSWR

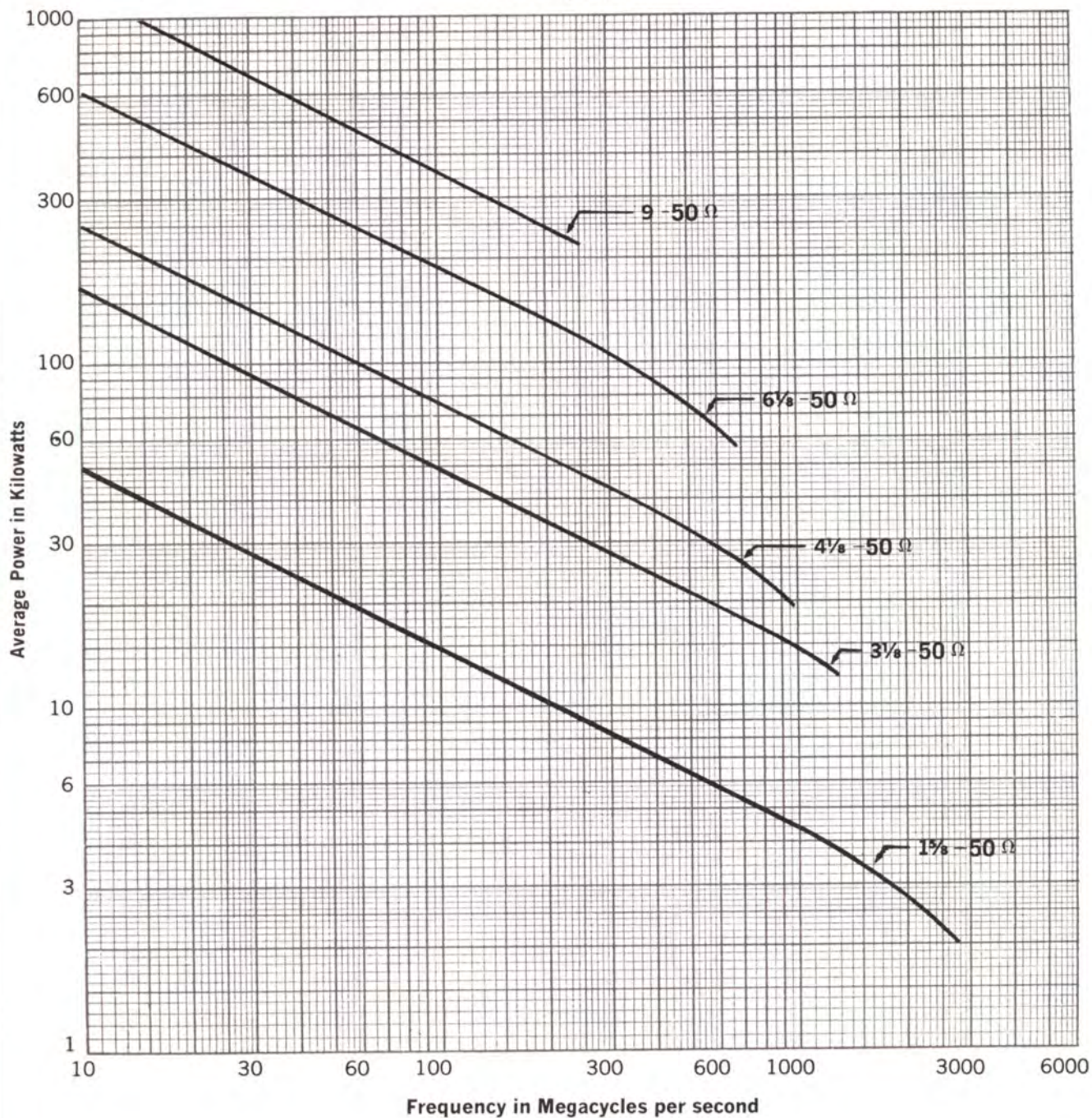



AUDIO FACILITIES



COLLINS 212E-1 DUAL CHANNEL SPEECH INPUT CONSOLE

The Collins 212E-1 assures broadcasters and recording studios of meeting a wide range of audio mixing requirements. Designed to meet the needs of most complex installations, the 212E-1 also serves equally well for the small, growing audio installation.

Beginning with the modules required for single studio operation, the Collins 212E-1 can be expanded by simply adding plug-in modules to mix 9 of 22 inputs and to provide two program lines and monitor circuits.

The 212E-1 is also available in a stereo version at additional investment. Stereo configuration provides two low-level stereo channels and an announce channel which is fed directly to both left and right outputs. Two medium-level stereo inputs for tape playback are provided with the option of two monaural channels and two remote mixers.

Although it has a wide variety of functions and controls, the 212E-1 is easily mastered even by the inexperienced operator. Color coded knobs and switches, in addition to write-in strips for line switches and mixing attenuators, make it possible to vary control functions without confusion to the operator.

Space is provided in the 212E-1 Console cabinet for seven preamplifiers plus booster, program, monitor and cueing amplifiers. A 499G-1 Rack Mounting Shelf is supplied for the power supply and relay units.

Spare contacts on lever-switches and an unwired lever-

switch are included for any desired custom wiring. An external position on the second VU meter input switch can be terminated at a patch panel to provide VU monitoring of external audio circuits. Talk-back on a remote line is simplified to a single switch operation after the initial setup of two switches. Lever-switches permit the selection of two program sources for each low level input fader and selection of four program sources for each remote input fader. The mixer attenuators are Daven step-type, with outputs connected to a key-switch so that each input can be fed to either of the two program channels when the Console is used for dual channel operation. The second channel also can be used for audition purposes during normal single-line program operation. All program, audition and remote lines may be monitored audibly and by VU meter.

Reliability of the 212E-1 has been proven by using carefully engineered, highly stable circuits and the finest quality components. The 212E-1 maintains excellent frequency response and low noise and distortion.

Maximum Number of Channels: Seven low level channels, two remote channels, two program channels, one monitor channel and one cueing channel when provided with: ten 356A-1 Preamplifiers, two 356B-1 or 356E-1 Amplifiers, one 356B-1 Program/Monitor Amplifier, one 274K-1 Relay Unit, two 409X-2 Power Supplies and two 499G-1 Rack Mounting Shelves.

Power Source: 115 v or 230 v ac $\pm 10\%$, 50-60 cps, single phase.

Input Impedance: Low level — 30/150/250/600 ohms balanced or unbalanced, shipped wired for 150 ohms. Remote lines — 150/600 ohms, shipped wired for 600 ohms.

Output Impedance: Line — 150/600 ohms, shipped wired for 600 ohms. Monitor — 600 ohms.

Input Level: Low — -50 dbm nominal (100 db gain). Remote — 0 dbm.

Gain: Low level to program line 100 db. Remote line to program line 54 db.

Output Level: Program — +18 dbm (65 mw). Monitor — +39 dbm (8 watts).

Response: ±1.5 db, 50-15,000 cps at program line.

Distortion: Less than 1% at +18 dbm at program line. Less than 3% at 8 watts out of Monitor Amplifier.

Noise: At least 68 db below +18 dbm output with -50 dbm low level input. (Equivalent input noise level -118 dbm or less.)

Size: 41 1/8" W, 11" H, 22 1/2" D (104.46 cm W, 27.94 cm H, 57.15 cm D).

Weight: 135 lbs. (61.24 kg), less modules.

Part No. 522 0773 006

Includes basic cabinet, four 356A-1 Preamplifiers, two 356A-1 Booster Amplifiers, two 356B-1 Program/monitor Amplifiers, one 409X-2 Power Supply and cable, one 274K-1 Relay Unit with necessary plug and cable assembly, one 499G-1 Rack Mounting Shelf, one set of tubes and instruction book.

No Part Number

FCC set of spare tubes for 212E-1 as listed above.

Part No. 553 2652 005

212E-1S Stereo Console

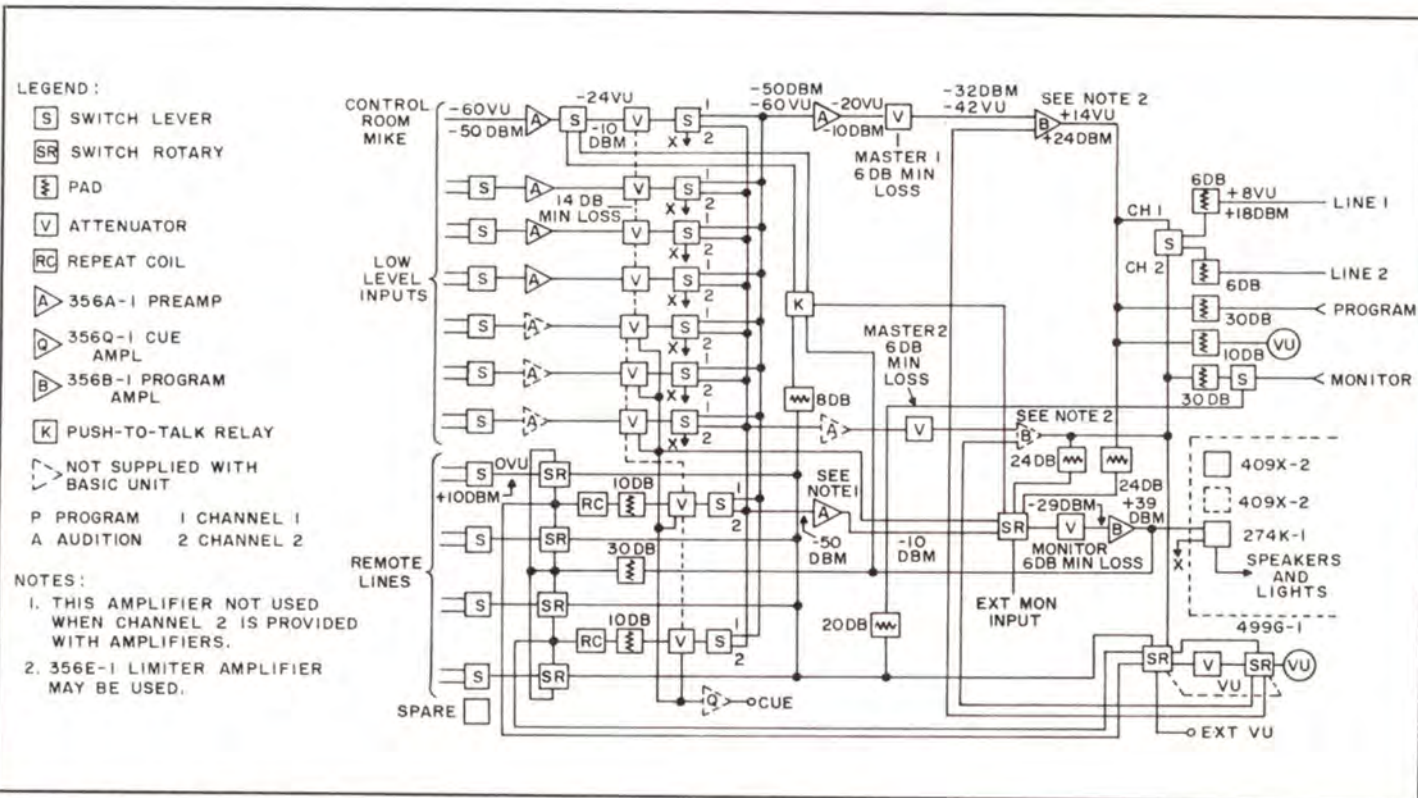

BLOCK DIAGRAM 212E-1

COLLINS 212G-1 SPEECH INPUT CONSOLE

Incorporating many design and control functions of the 212E-1, the 212G-1 is a flexible, self-contained unit that provides complete control over simultaneous broadcasting and auditioning from any combination of 9 of 13 inputs.

The Collins 212G-1 Console is designed for medium-size radio stations and recording studios which demand a versatile console at production line price. Main features of the 212G-1 are its quality, reliability, ease of servicing plug-in modules and wide variety of controls.

The long, low design of the 212G-1 assures easy operation on an uncrowded control panel. Finger-fitted knobs with big skirts are easily grasped for exact level control.

The VU meter is centered on the panel directly in front of the operator. The lights are external to the meter and

may be replaced without removing the meter face. The meter lights operate from the relay supply voltage giving visual indication of proper operation. A switch allows the VU meter to measure program or external audio levels and gain reduction when a 356E-1 Limiting Amplifier is substituted for a Collins 356B-1 Program Amplifier.

The 356B-1 Monitor Amplifier input may be switched to program, audition or external inputs. Six cueing-type attenuators, a plug-in cueing amplifier and a cueing speaker free the 212G-1 monitor circuits from cueing service.

The hinged top of the Collins 212G-1 Console provides adequate room to service components while the panel remains in position and the unit is operating. No high voltage points are exposed when the cabinet is opened. A



COLLINS 212G-1 SPEECH INPUT CONSOLE

cover protects the terminal wiring strip and connector wiring.

Any of eight circuits may be selected on a terminal strip for control of speakers and warning lights. Extra wiring terminals and two spare lever-switches are provided.

Only two tube types are used in the 212G-1. Slots in the bottom, back and top of the Console provide adequate ventilation for low operating temperatures insuring longer component life.

Maximum Number of Channels: Six low level channels, two medium level channels, one net/remote channel, one program channel, one monitor channel and one cueing channel when provided with: eight 356A-1 Preamplifiers, one 356B-1 or 356E-1 Amplifier, one 356B-1 Program/Monitor Amplifier, one 274K-2 Relay Unit, one 356Q-1 Cueing Amplifier and one 409X-2 Power Supply.

Power Source: 115 v or 230 v ac $\pm 10\%$, 50-60 cps, single phase.

Input Impedance: Low level — 30/150/250/600 ohms balanced or unbalanced, shipped wired for 150 ohms. Net/remote lines — 50/150/250/600 ohms,

shipped wired for 600 ohms. Medium level — 600 ohms unbalanced.

Output Impedance: Line — 150/600 ohms, shipped wired for 600 ohms. Monitor — 600 ohms.

Input Level: Low — -50 dbm nominal (100 db gain). Net/remote — 0 dbm. Medium — -10 dbm nominal (60 db gain).

Gain: Low level to program line 100 db. Remote line to program line 53 db. Medium level to program line 62 db.

Output Level: Program — +18 dbm (65 mw). Monitor — +39 dbm (8 watts).

Response: ± 1.5 db, 50-15,000 cps at program line.

Distortion: Less than 1% at +18 dbm at program line. Less than 3% at 8 watts out of Monitor Amplifier.

Noise: At least 68 db below +18 dbm output with -50 dbm low level input. (Equivalent input noise level -118 dbm or less.)

Size: 41 $\frac{1}{8}$ " W, 8 $\frac{1}{4}$ " H, 21 $\frac{1}{8}$ " D (104.3 cm W, 20.96 cm H, 53.66 cm D).

Weight: 75 lbs. (34.02 kg), less modules.

Part No. 522 1605

Includes basic cabinet, three 356A-1 Preamplifiers, two 356A-1 boosters, two 356B-1 Program/monitor Amplifiers, one 409X-2 Power Supply, one 274K-2 Relay Unit, one set of tubes and instruction book.

No Part Number

FCC set of spare tubes for 212G-1 as listed above.

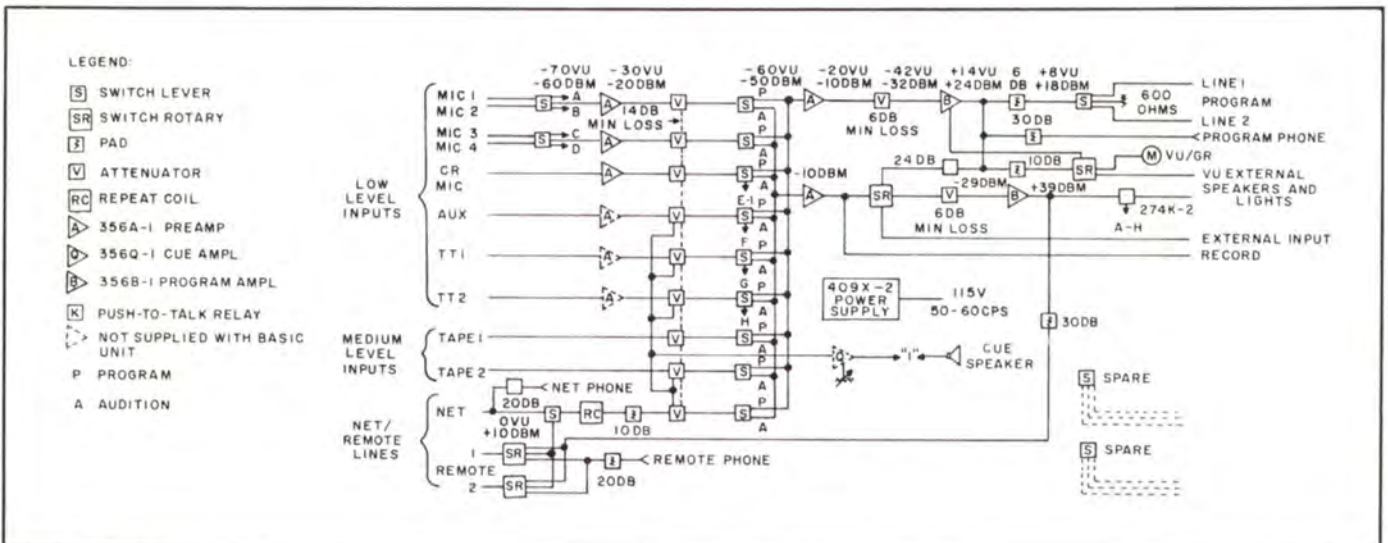

BLOCK DIAGRAM 212G-1



McMARTIN MODEL LT-80A AUDIO AMPLIFIER

The LT-80A is a transistorized light weight audio amplifier which delivers a full 8 watt rms with less than 1% distortion from 50 to 15,000 cps at 1 watt. Hand wired circuitry provides a compact unit weighing less than 6 pounds. The unit is provided with complete overload protection and operates at full performance in high ambient temperatures to 130° F.

SPECIFICATIONS

Power Output: 8 watts rms @ 1000 cps. 12 watts music power. 20 watts peak power.

Frequency Response: 30 to 15,000 cps ± 2 db. 20 to 20,000 cps ± 3 db.

Distortion: Less than 1% 50 to 15,000 cps @ 1 watt. Less than 1% @ 1000 cps @ 8 watts.

Hum and Noise: Microphone(s) —60 db below 8 watts. Program —70 db below 8 watts. Phono (with PH-6A) —60 db below 8 watts.

Inputs: Microphone(s) (1) HiZ; 150 K ohms, .008 v for 8 watts.

Program: Bridging; 10 K ohms, 0.8 v for 8 watts.

Phono (with PH-6A): Magnetic, ceramic, crystal.

600 (with MT-6): Balanced; —10 dbm for 8 watts.

Tuner (with PH-7): HiZ; 270 K ohms, +5 db gain increase.

Outputs: 4, 8, 16, 150 ohms, 70.7 v/600 ohms.

Controls: (1) Microphone Gain. Program Gain. Tone (cut to —20 db @ 10,000 cps). Power ON-OFF switch.

Semi-conductors:

4—2N508	2—2N1501
1—2N1371	2—1N1693
1—2N1102	or equivalents

Power Supply: 120 v ac, 50/60 cps, fused, 18 watts max.

Ambient Temperature: Full performance to 130° F.

Dimensions & Finish: 9" w x 7" d x 4½" h, Black & Natural Gray.

Shipping Weight: 6 lbs.

Part No. 099 2815 000

SPECIAL NOTES—Plastic "Guard Nuts" are provided to allow tamper-proof setting of all amplifier controls. Advanced circuitry provides stable operation under extremely adverse conditions such as open or shorted speaker lines and high ambient temperature.

PLUG-IN ACCESSORIES

MT-6—Shielded 600 ohm input transformer. Frequency response 20 to 20,000 cps.

PH-6A—Phonograph preamplifier. Equalized for magnetic, ceramic, or crystal cartridges.

PH-7—Program preamplifier. Converts the bridging input to 270 K ohms and provides extra gain of 5 db.

RP-80



The RP-80 is a rack mounting adapter for the Model LT-80A.

Part No. 099 2816 000

COLLINS 356A-1 PREAMPLIFIER



Usually used to feed a line amplifier in the Collins Consoles, the 356A-1 operates from a low level microphone or similar source and has sufficient output to drive a program amplifier or audition facilities.

Input Impedance: Unloaded transformer, source impedance 30/150/250/600 ohms balanced or unbalanced, shipped wired for 150 ohms.

Input Level: -60 db nominal.

Output Impedance: 150/600 ohms balanced or unbalanced, shipped wired for 600 ohms.

Output Level: +18 dbm maximum.

Gain: 40 db.

Frequency Response: ± 1 db, 50-15,000 cps.

Distortion: 0.5% maximum.

Noise: -118 dbm at input, or 96 db below full output.

Tubes: Two 5879.

Power Requirements: 6.3 v ac or dc at 0.3 amp. 250 v dc at 6.5 ma or 300 v dc at 7.5 ma.

Size: $2\frac{1}{8}$ " W, $4\frac{5}{8}$ " H, $9\frac{1}{2}$ " D (5.40 cm W, 11.75 cm H, 24.13 cm D).

Weight: $2\frac{1}{4}$ lbs. (1.02 kg).

Part No. 522 0389 005
No Part Number
100% spare tube kit.

COLLINS 356B-1 PROGRAM/MONITOR AMPLIFIER

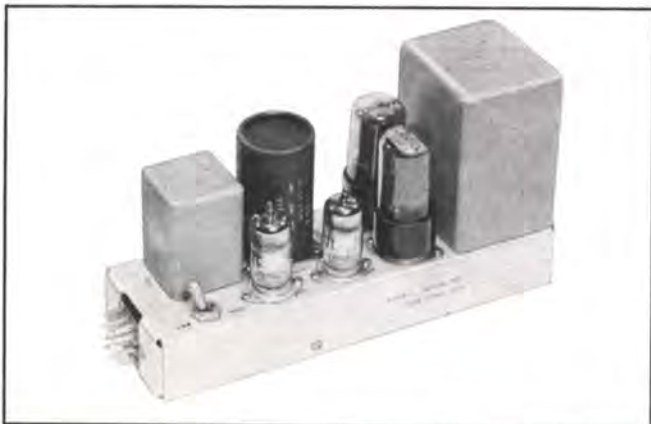

Used as the program line amplifier and monitor amplifier in Collins Consoles, the 356B-1 is a three stage amplifier with push-pull output and has a switch for high or low gain.

Input Impedance: Unloaded transformer, source impedance 150/600 ohms balanced or unbalanced, shipped wired for 600 ohms.

Input Level: -32 dbm.

Output Impedance: 150/600 ohms balanced or unbalanced, shipped wired for 600 ohms.

Output Level: +39 dbm (8 watts) maximum.

Gain: 56 db or 68 db, selected by toggle switch.

Frequency Response: ± 1 db, 50-15,000 cps.

Distortion: 0.5% maximum at +30 dbm, 3% maximum at +39 dbm (8 watts).

Noise: -116 dbm at input, or 90 db below full output of 1 watt.

Tubes: Two 5879 and two 6V6.

Power Requirements: 6.3 v ac at 1.2 amps. 63 ma at 250 v dc at 1 watt output. 75 ma at 300 v dc at 1 watt output. 88 ma at 300 v dc at 8 watts output.

Size: $2\frac{7}{8}$ " W, $5\frac{3}{4}$ " H, $9\frac{1}{2}$ " D (7.3 cm W, 14.61 cm H, 24.13 cm D).

Weight: 6 lbs. (2.72 kg).

Part No. 522 0390 005
No Part Number
100% spare tube kit.

COLLINS 356E-1 LIMITING AMPLIFIER



Designed for Collins Speech Input Consoles to permit unattended remote audio operation, the 356E-1 can be used to control level differences between two or more sources, as a program line compressor, in an expander-compressor operation or as a program amplifier.

The module consists of a push-pull variable gain input stage driving a push-pull output stage. A bias rectifier provides bias to regulate gain of the input stage. A decal to convert a VU meter to a gain reduction meter is furnished with the unit.

Input Impedance: Unloaded transformer, source impedance 150/600 ohms balanced or unbalanced, shipped wired for 600 ohms.

Input Level: -54 dbm to -24 dbm, with threshold control set at 0 dbm output. -34 dbm to -4 dbm, with threshold control set at +20 dbm output. -24 dbm to +6 dbm, with threshold control set at +30 dbm output. (0 dbm equals 1 mw across 600 ohms.)

Output Impedance: 150/600 ohms balanced or unbalanced, shipped wired for 600 ohms.

Output Level: 0 dbm to +18 dbm, with threshold control set at 0 dbm output. +20 dbm to +30 dbm, with threshold control set at +20 dbm output. +30 to +36 dbm, with threshold control set at +30 dbm output.

Response: ± 1 db, 50-15,000 cps.

Distortion: 1.5% maximum, 50-15,000 cps, with no compression. 2% maximum, 50-15,000 cps, at any level up to 30 db gain reduction, with threshold control set at +20 dbm output.

Output Noise: -50 dbm or less, threshold control set for +20 dbm output.

Compression Ratio: Adjustable 1.6:1 to 5:1, with 3:1 optimum performance over a 30 db range at input.

Attack Time: 11 milliseconds, with switch set for dual operation. 62 milliseconds, with switch set for average operation.

Release Time: 0.9 seconds for 63% recovery, with switch set for dual operation. 5.2 seconds for 63% recovery, with switch at average operation.

Gain: 54 db.

Controls: Dual/Average toggle switch at top near front of chassis.

Tubes: One GL-6386 Variable Gain Input Amplifier, two 6V6GT Output Amplifiers and one 6AL5 Bias Rectifier.

Power Source: 6.3 v ac at 1.55 amps, 300 v dc at 77 ma. Size: 3" W, 5 $\frac{3}{8}$ " H, 9" D (7.63 cm W, 13.65 cm H, 22.86 cm D).

Weight: 5 lbs. (2.27 kg).

Part No. 522 0394 005
No Part Number
100% spare tube kit.

COLLINS 356Q-1 CUE AMPLIFIER



Designed for use in the Collins Consoles, the 356Q-1 is a two stage amplifier used to amplify signals from the cueing line. The 212G-1 has provisions for controlling the gain of the amplifier and includes a speaker for the output.

Gain: 55 db.

Range: 300-10,000 cps.

Input Level: -30 dbm nominal.

Output Level: +20 dbm (100 mw) nominal.

Input Impedance: 600 ohms nominal.

Output Impedance: 4 ohms.

Tubes: Two 5879.

Power Requirements: 6.3 v ac or dc at 0.3 amp, 300 v dc at 7.5 ma.

Size: 2 $\frac{1}{8}$ " W, 4 $\frac{3}{8}$ " H, 9 $\frac{1}{2}$ " D (5.4 cm W, 11.75 cm H, 24.13 cm D).

Weight: 2 $\frac{1}{4}$ lbs. (1.02 kg).

Part No. 522 1607 00
No Part Number
100% spare tube kit.

COLLINS 409X-2 POWER SUPPLY



A plug-in module for Collins Consoles, this unit uses silicon rectifiers in the high voltage circuit for long life and to eliminate heat associated with vacuum tube rectifiers.

Output Voltages: Up to 250 ma at 300 v dc adjustable. 6.0 amps at 6.3 v ac. 1.0 amp at 12 v dc.

Power Requirements: 115/230 v ac $\pm 10\%$, 50-60 cps, single phase.

Power Input: 225 watts maximum.

Size: 8" W, 6" H, 9 $\frac{1}{2}$ " D (20.32 cm W, 15.24 cm H, 24.13 cm D).

Weight: 25 lbs. (11.34 kg).

Part No. 522 1691 00
Part No. 542 3024 004
Power Supply Cable.

COLLINS 274K-1 RELAY UNIT



Used in Collins 212E-1 Console, this unit has four relays to control studio speakers and warning lights. Each relay is provided with a series shunt circuit to minimize switching transients and arcing. Noise is held to a minimum by mounting the relays on rubber. The 409X-2 Power Supply provides 12 v dc at 1 amp and studio wiring provides power for the warning lights.

Connectors: Howard Jones P-312-AB connector mounted on the front surface and P-315-CCE connector on a 5 $\frac{1}{2}$ " pendant cable.

Size: 2 $\frac{1}{2}$ " W, 5 $\frac{1}{2}$ " H, 9" D (6.35 cm W, 13.97 cm H, 22.86 cm D).

Weight: 2 $\frac{1}{2}$ lbs. (1.13 kg).

Part No. 522 0391 005

COLLINS 274K-2 RELAY UNIT

Used with the Collins 212G-1 and 212F-2 Consoles, the 274K-2 is similar to the 274K-1 in all specifications except that relays are unenergized in standby.

Part No. 522 1606 00

COLLINS CONSOLE TEST CABLE



Permits operation and service of any module while removed from the console cabinet.

Part No. 541 6473 003

COLLINS CONSOLE JUMPER PLUG



For use where high level signal inputs eliminate the need for 356A-1 Preamplifiers.

Part No. 541 6459 002

26J-1 AUTO-LEVEL LIMITING AMPLIFIER

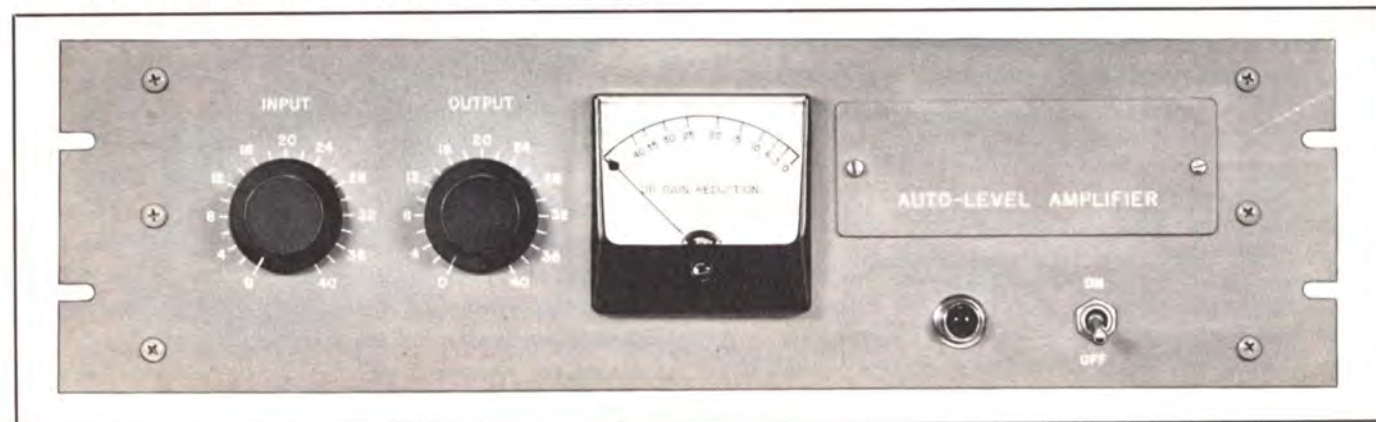

The average program level of the radio broadcast station can be automatically and effectively raised with the 26J-1 Auto-Level Limiting Amplifier. The resulting effect

COLLINS 499G-1 SHELF



The 499G-1 is a rack mounting shelf used to mount amplifiers, relay units and power supplies associated with the Collins 212E-1 Speech Input Console. The unit is a fixed type rack mounting shelf with a hinged, front panel 8 $\frac{1}{2}$ " H by 17 $\frac{3}{8}$ " W. The floor of the shelf is of cadmium plated, perforated sheet metal.

A Howard Jones barrier strip is mounted at the front or back of the unit. Holes on both sides at front and back allow wiring to individual style. The perforated bottom plate allows mounting components without drilling additional holes.

Size: 19" W, 8 $\frac{3}{4}$ " H, 14" D (48.26 cm W, 22.23 cm H, 35.56 cm D).

Weight: 11 lbs. (4.99 kg).

Part No. 522 0774 00

COLLINS PLUG-IN BRACKET ASSEMBLIES

Plug-in bracket assemblies in 12-pin models without cable are available to facilitate mounting of 356A/B/E-1 Amplifiers in the 499G-1 Rack Mounting Shelf. Also available are 12- and 15-pin plug-in bracket assemblies with cable for use with 274K-1 or 274K-2 Relay Units.

Part No. 542 3038 002
12-pin assembly without cable.
Part No. 542 3040 003
12-pin assembly with cable.

Part No. 542 3039 002
15-pin assembly without cable.
Part No. 542 3041 004
15-pin assembly with cable.

of the 26J-1 is similar to turning up the volume of the radio receiver so that the low level transmission is as well received as the high level transmission.

Automatic fades between microphone and recorded music are also accomplished with the 26J-1. By setting the microphone level at a higher level than the turntable, the automatic fade occurs when the microphone is activated. The higher microphone level automatically fades the music into the background and allows the speech to come through clearly. When the voice portion is absent, the 26J-1 restores the music level to normal. Since these fades are done automatically and electronically, they are far smoother and superior to manual fades.

The 26J-1 does not act as a peak limiting amplifier but functions on a low compression ratio which allows limiting action without noticeable effect on program material. With the slow action and compression ratio of the 26J-1, it is possible to limit up to 30 db without a noticeable effect other than bringing up the average listening level of the program material.

Working in conjunction with the Collins 26U-1 Peak Limiting Amplifier, the two units provide excellent peak limiting as well as average program limiting. The wide dynamic ranges used in most classical and popular music require considerable compression to allow low and high passages to be broadcast equally well.

The Collins 26U-1 Peak Limiting Amplifier, ideally located at the transmitter, protects over-modulation of the transmitter, and the 26J-1 Auto-Level Limiting Amplifier, located at the studio, boosts the average and low level program portions. Thus, these two units allow even the low-priced home and car receivers, which are not capable of reproducing wide dynamic ranges, to receive the entire broadcast as transmitted.

In those instances where there is not a good signal-to-noise ratio, such as old phonograph records and sports events with background noises, the 26J-1 can be operated as a straight amplifier. The limiting action may be disabled by turning off the gain reduction switch.

Frequency Response: ± 1 db, 50-15,000 cps.

Gain: 25 db maximum as shipped, 41 db maximum, with input pad changed from 22 db to 6 db.

Input Impedance: 600 ohms unbalanced.

Input Level: Adjustable, -26 dbm to +30 dbm. Easily changed 22 db "T" pad in input circuit available. (0 dbm equals 1 mw across 600 ohms.)

Output Impedance: 600 ohms unbalanced.

Output Level: Adjustable, -24 dbm to +30 dbm; +14 dbm nominal.

Distortion: 1.5% maximum, 50-15,000 cps, with no compression. 2% maximum distortion, 50-15,000 cps, at any level up to 30 db gain reduction, with threshold set for 3:1 compression ratio.

Output Noise: -50 dbm or less. (Threshold set for 3:1 ratio.)

Compression Ratio: 3:1 optimum; adjustable 1.6:1 to 5:1.

Attack Time: 11 milliseconds, with switch set for dual operation, 62 milliseconds, with switch set for average operation.

Release Time: 0.9 seconds for 63% recovery, with switch set for dual operation. 5.2 seconds for 63% recovery, with switch set for average operation.

Power Source: 115 v or 230 v ac, 50-60 cps, single phase. Shipped wired for 115 v.

Size: 19" W, 5 1/2" H, 9" D (48.26 cm W, 13.97 cm H, 22.86 cm D).

Weight: 16 lbs. (7.26 kg).

Part No. 099 2814 00
No Part Number
FCC set of spare tubes (includes two silicon rectifiers).

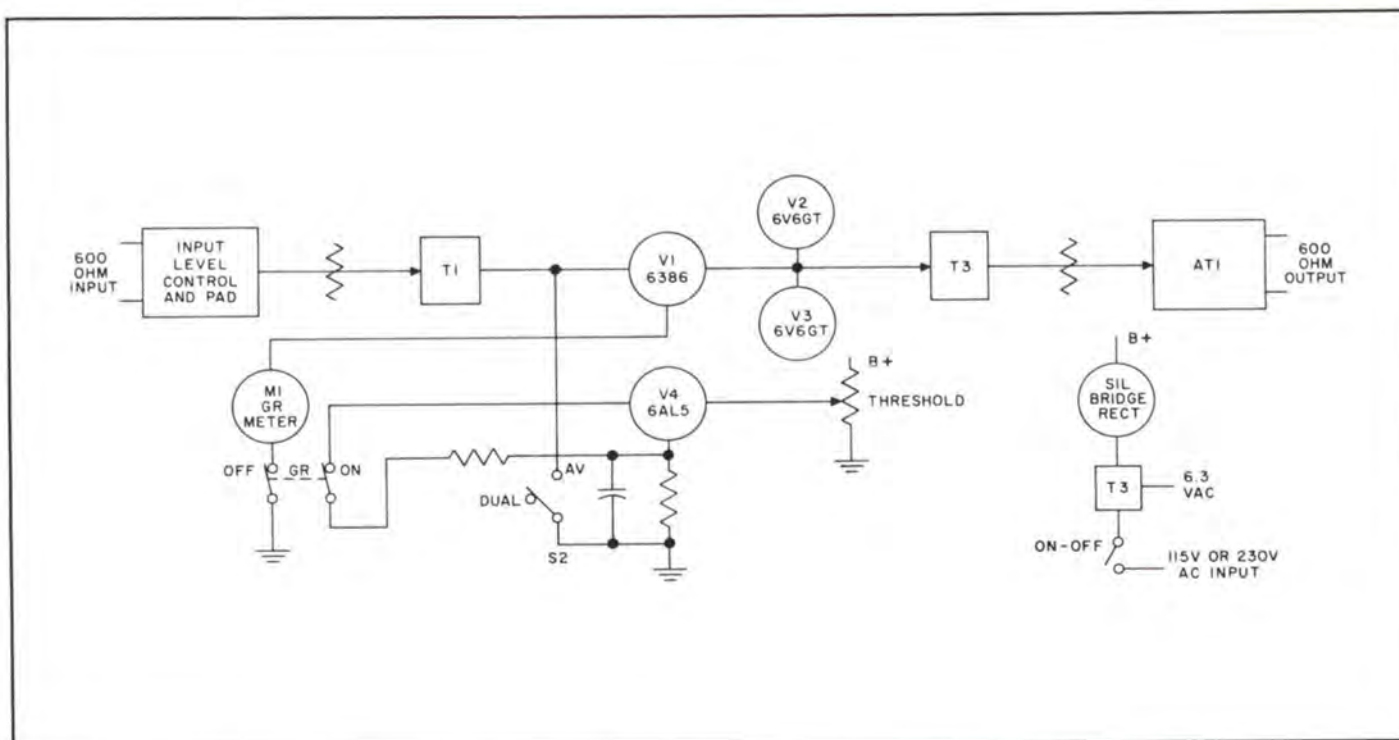

BLOCK DIAGRAM 26J-1

COLLINS 26U-1 LIMITING AMPLIFIER



Designed to achieve maximum modulation with minimum distortion, the Collins 26U-1 Limiting Amplifier provides full tonal range broadcasting with thump-free performance.

The Collins Limiting Amplifier limits loud audio passages to prevent overmodulation, distortion and adjacent channel interference, while allowing low level passages to be broadcast in their true range.

The transmission range of the station's signal and the over-all efficiency of the transmitter are increased through the limiting action which permits a higher average modulation level.

When used with recording equipment or with a public address system, the 26U-1 prevents overloading, and by allowing a higher average audio level, the limiting amplifier improves the signal-to-noise ratio.

A self-balancing circuit eliminates the need of tube selection or delicate balancing procedures usually associated with peak limiters. The Collins Limiting Amplifier is capable of greater than 30 db compression.

Conventional circuitry, negative feedback, full wave rectification for control voltage and silicon rectifiers in the power supply are incorporated into this unit.

An illuminated VU meter with a special scale calibrated in VU and db of compression, which measures five functions, is provided in the Collins Limiting Amplifier.

The VU meter attenuator and a rotary switch allow measurement of external gain reduction, db of compression and levels of input, output and external audio circuits. This external meter circuit measures audio levels on other program lines, eliminating the need for an additional VU meter panel.

Silicon diodes and extended life electrolytic capacitors provide an efficient, low heat power supply with a minimum of maintenance. A voltage regulator provides stabilized reference voltages. Input, output and VU meter level controls are Daven step-type.

The 26U-1 consists of a push-pull variable gain input stage, a push-pull interstage voltage amplifier, and a push-pull output stage. A bias rectifier supplies dc bias from the signal output to regulate the gain of the input stage. A self-contained power supply provides the plate and filament voltages.

Designed for rack mounting, the Collins Limiting Amplifier has a minimum number of controls, tubes and tube types. It has a hinged front panel for access to internal wiring and components.

The panel is finished with blue-gray enamel, and the chassis is cadmium plated and chromate dipped.

Frequency Response: ± 1.5 db, 50-15,000 cps.

Gain: 32 db minimum.

Input Impedance: 600 ohms unbalanced.

Input Level: -20 dbm to +20 dbm. Note: 0 dbm equals 1 mw across 600 ohms.

Output Impedance: 600 ohms unbalanced adjustable, or 600 ohms balanced fixed level.

Output Level: -20 dbm to +20 dbm.

Distortion: 1.5% maximum.

Output Noise: -50 dbm or less.

Compression Ratio: 12:1 first 10 db above threshold.

Attack Time: Adjustable, 0.5-3.0 milliseconds.

Release Time: Adjustable, .5-3.0 seconds for 63% recovery.

Power Source: 115 v or 230 v ac, 50-60 cps, single phase.

Shipped wired for 115 v.

Size: 19" W, 10 $\frac{1}{2}$ " H, 9" D (48.26 cm W, 26.67 cm H, 22.86 cm D).

Weight: 32 $\frac{1}{2}$ lbs. (14.75 kg).

Part No. 522 0966 00

No Part Number

100% set of spare tubes.

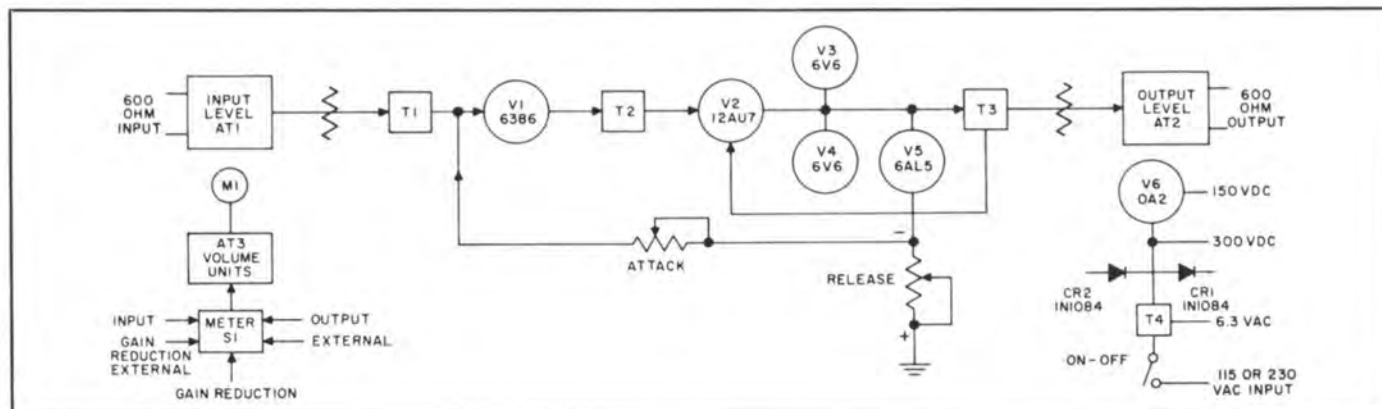

BLOCK DIAGRAM 26U-1

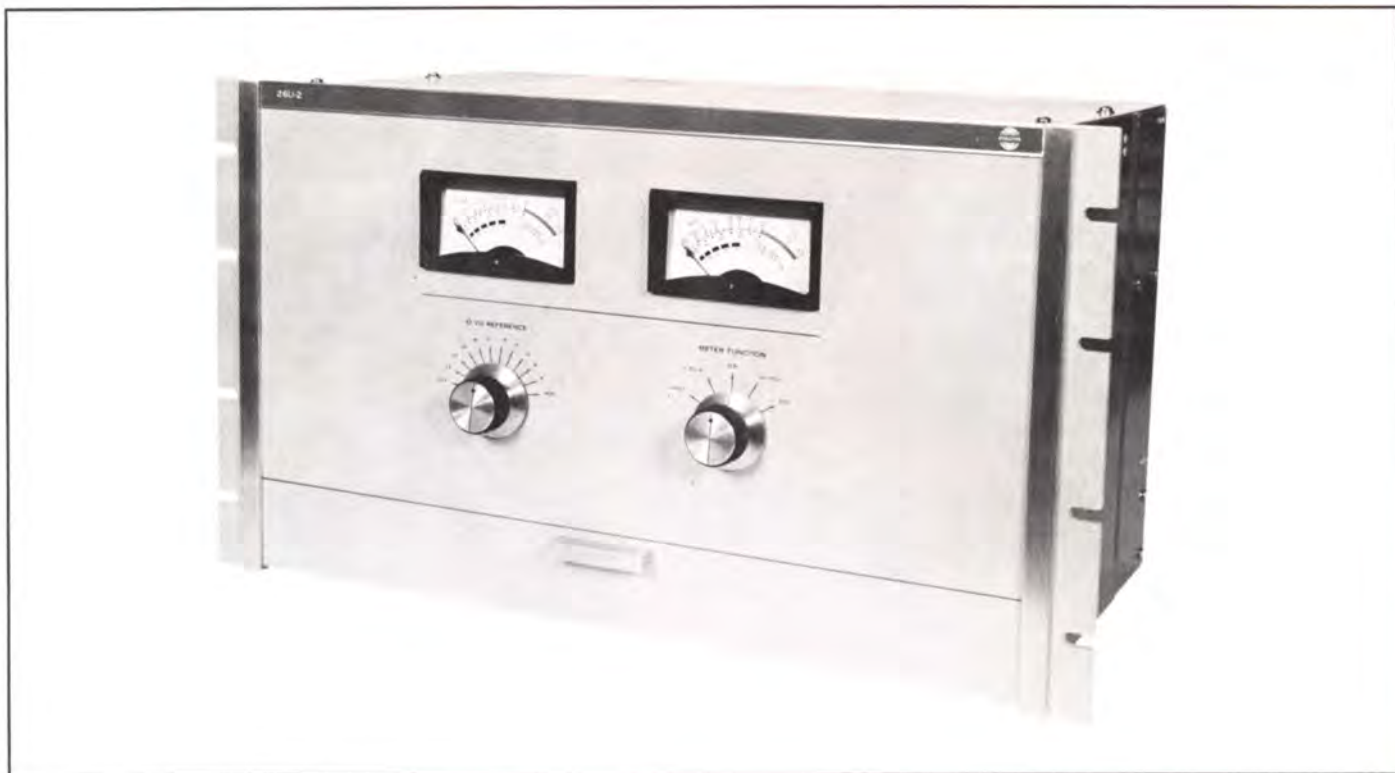

COLLINS 26U-2 STEREO LIMITING AMPLIFIER

Easy to operate and maintain and affording maximum flexibility, the Collins 26U-2 Stereo Limiting Amplifier is designed to permit maximum modulation with minimum distortion. It provides full tonal range broadcasting with thump-free performance.

The 26U-2 limits loud audio passage to prevent over-modulation, distortion and adjacent channel interference, while raising low level passages to be broadcast in their true value.

When used with stereo recording equipment, the Collins Stereo Limiting Amplifier prevents overloading and improves signal-to-noise ratio by allowing a higher average audio level.

Based on the time-proven circuitry of the Collins 26U-1, the stereo limiter has conservatively-rated components and long life. Typical mean time between failures: four years of continuous service.

The 26U-2 is designed to meet any requirement of the broadcaster. It may be used as a single channel limiter, two monaural channels or for stereo broadcasting. A switch in the subpanel selects either stereo or monaural operation.

The self-balanced circuit eliminates the need for tube selection or delicate balancing procedures usually associated with peak limiters. The Collins 26U-2 is capable of greater than 30 db compression.

Two illuminated VU meters, calibrated in VU and db of compression, which measure five functions, are incorporated. The meters' attenuator and function switch allow

measurement of external and internal gain reduction (db of compression), and levels of input, output and external audio circuits. The external circuit measures audio levels of other program lines, eliminating the need for an additional VU meter panel.

Silicon diodes provide an efficient, low heat power supply with a minimum of maintenance. A voltage regulator provides stabilized reference voltages. Input and output level controls are continuously variable bridge-T attenuators.

Occupying only 10.5 inches of rack space, the Collins 26U-2 has a minimum number of controls, tubes and tube types. A hinged front panel with magnetic latches provides access to the subpanel controls.

Size: 19" W, 10½" H, 10¼" total D — 9¼" behind panel (48.26 cm W, 26.67 cm H, 26.04 cm total D — 23.5 cm behind panel).

Weight: 35 lbs. (15.88 kg).

Power Source: 115 v or 230 v ac, 50-60 cps, single phase (150 watts at 115 v ac).

Frequency Range: 50-15,000 cps ± 1.5 db.

Input: 600 ohm bridged T (ungrounded), —20 dbm to +20 dbm.

Output: 600 ohm bridged T (ungrounded), —20 dbm to +20 dbm.

Distortion: 1% maximum.

Output Noise: —50 dbm or less.

Cross-Talk: 60 db minimum.

Compression Ratio: 12:1 first 10 db above threshold.

Gain: 40 db.

Attack Time: Adjustable, 0.5-3.0 milliseconds.

Release Time: Adjustable, 0.5-3.0 seconds.

Controls:

- Panel Mounted
 - Meter Selector Switch
 - Meter Multiplier Selector
- Subpanel Controls
 - Input Level (2)
 - Output Level (2)
 - Gain Reduction Meter Zero (2)
 - Gain Reduction Balance (2)
 - Stereo-Mono
 - Power ON-OFF
- Rear Chassis Controls
 - Attack Time (2)
 - Release Time (2)

Protection: Overload fuse in primary circuit.

Metering: Two 3 1/2" voltmeters which can be switched to measure Input Level, External Gain Reduction, Gain Reduction, Output Level and External Level.

Tube and Rectifier Complement:

- 2 GL-6386 Variable gain input stages
- 2 12AU7 Interstage voltage amplifiers
- 4 6V6GTA Output amplifiers
- 2 6AL5 Limiter bias rectifiers
- 2 OA2 Voltage regulators
- 4 1N3256 Power rectifiers (silicon, commercial)

Part No. 522 3237 00

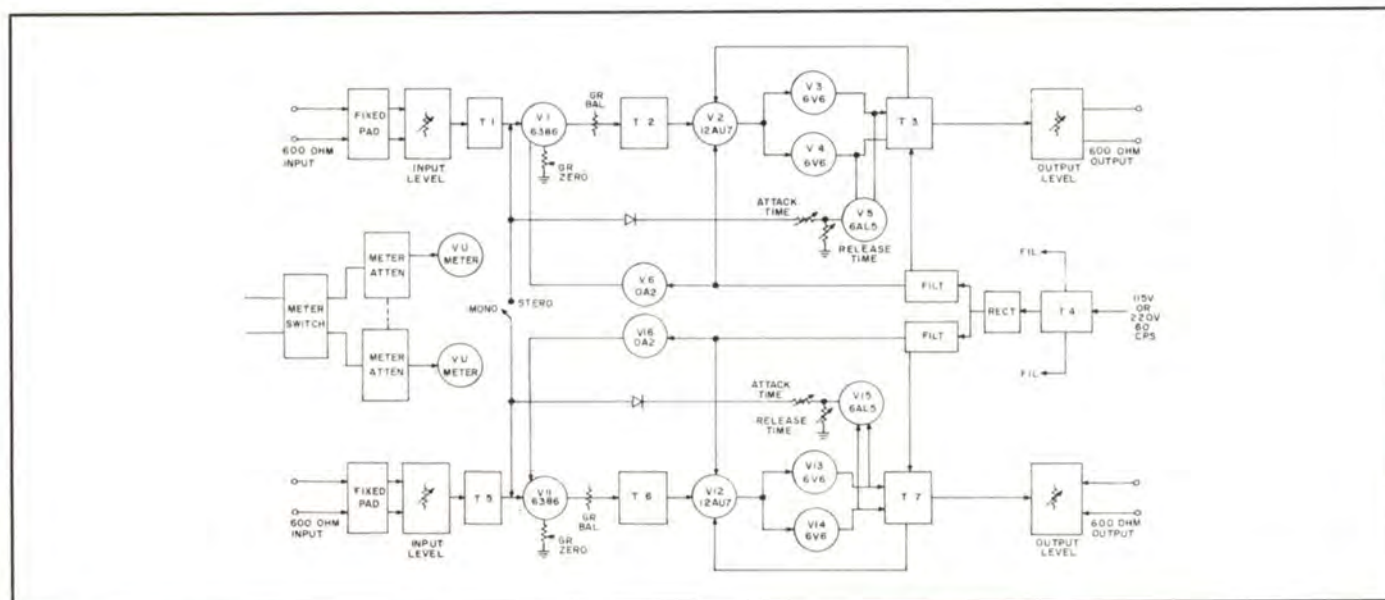

BLOCK DIAGRAM 26U-2

COLLINS TT-400/200 TURNTABLES



Collins Turntables feature a simplicity of design which requires only three moving parts in the drive mechanism. There is no complicated linkage system to break down or to add to wow or rumble.

The turntables, constructed of heavy cast aluminum with a blue-gray wrinkle finish, are non-magnetic. A gear speed shift offers selection of 33, 45 and 78 rpm, with neutral between slots. An indentation in the turntable eliminates the need for a spindle adaptor for 7" 45 rpm records.

The tables are rim-driven by a single molded neoprene idler wheel. The idler wheel serves only to transfer power to the rim. It does not determine the speed of the table. Normal wear and reduction of the idler wheel have no effect on the precision of the platter speed.

	Speed	Noise level*	Speed Acceleration
16" TT-400	33 1/3	-48 db	1/10 rev.
	45	-47 db	1/8 rev.
	78	-42 db	1/2 rev.
12" TT-400	33 1/3	-49 db	1/16 rev.
	45	-49 db	1/12 rev.
	78	-46 db	1/3 rev.

*Based on reference level of 7 cm/sec., at 1,000 cps

Models:

- TT-400 — 16", 4-pole motor
- TT-400S — 16", synchronous motor
- TT-450S — 16", synchronous motor, 50 cps
- TT-200 — 12", 4-pole motor
- TT-200S — 12", synchronous motor
- TT-250S — 12", synchronous motor, 50 cps

Size: TT-400 and TT-400S — 2" (5.08 cm) above base plate, 6" (15.24 cm) below base plate, overall base 19 5/8" square (49.85 cm).

Size: TT-200 — 1½" (3.81 cm) above table, 4¼" (10.8 cm) below table, base 15¾" W, 14½" D (39.05 cm W, 36.83 cm D).

TT-200S — Same as TT-200, except 6" (15.24 cm) below table.

Weight: TT-400 — 53 lbs. (24.04 kg). TT-200 — 22 lbs. (10.23 kg).

Part No. 097 3736 00 (Type TT-400) Part No. 097 3971 00 (Type TT-200)
 Part No. 097 3737 00 (Type TT-400S) Part No. 097 3811 00 (Type TT-200S)
 Part No. 097 6286 00 (Type TT-450S) Part No. 097 6285 00 (Type TT-250S)
 Part No. 097 8123 00

Rubber pad to fill turntable indentation for TT-400/200 series. Allows playing small hole 33½ rpm records.

Part No. 097 7523 00

220 v to 115 v step-down transformer. 150 watts, for use with TT-400/200 turntables.

COLLINS TURNTABLE CABINET



Has front door for accessibility to turntable components. Cutout on top for one Collins TT-400 or TT-200 Series Turntable. Cabinet finished in Kashmir walnut Formica. Other coverings available on special order. Specify turntable model number.

Size: 24" W, 30" H, 24" D (60.96 cm W, 76.2 cm H).

Part No. 097 6131 00 (Type TCFW-2)
 For use with TT-200 series turntables.
 Part No. 097 6225 00 (Type TCFW-4)
 For use with TT-400 series turntables.

COLLINS 356H-1 PHONO EQUALIZER PREAMP

An economical unit to equalize and amplify the output signal of a magnetic phono cartridge, this small transistorized unit is used to replace passive equalizers and console or turntable preamplifiers. The housing of the unit is constructed of steel for magnetic shielding.

Control shafts are 3" long and may be cut to proper length after mounting the unit in the cabinet. The 356H-1 provides choices between two inputs and between four response curves: (1) Flat, for test purposes, and mike preamp use; (2) Hi-Boost, which has a 4 db rise above

normal at 15,000 cps; (3) Normal, which is the RIAA equalizing curve, and (4) Hi-Cut, which has a 4 db drop below the Normal curve at 15,000 cps.

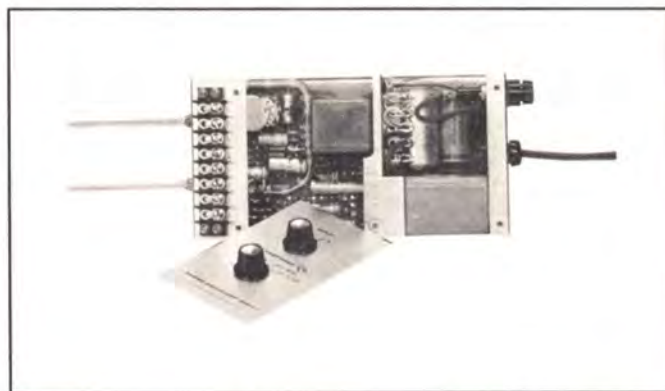

Frequency Range: 30-15,000 cps. (Typical — "Flat" position ±1.5 db, 20-20,000 cps).

Frequency Response: ±1.5 db from RIAA playback equalization response curve.

Output Level: -10 dbm, ±3 db with -50 dbm input at 1,000 cps.

Output Impedance: 150/600 ohms, balanced or unbalanced.

Input Impedance: High impedance bridging, unbalanced.

Distortion: 1.0% maximum, 30-15,000 cps at -10 dbm output.

Output Noise: Signal-to-noise ratio 60 db.

Gain: 40 db at 1000 cps minimum.

Power Source: 120/240 v ac, ±5%, 50/60 cps.

Size: 4" W, 2" H, 7¾" D (10.16 cm W, 5.08 cm H, 19.60 cm D).

Weight: 5 lbs. (2.27 kg).

Part No. 522 2468 00

GRAY 602C EQUALIZER

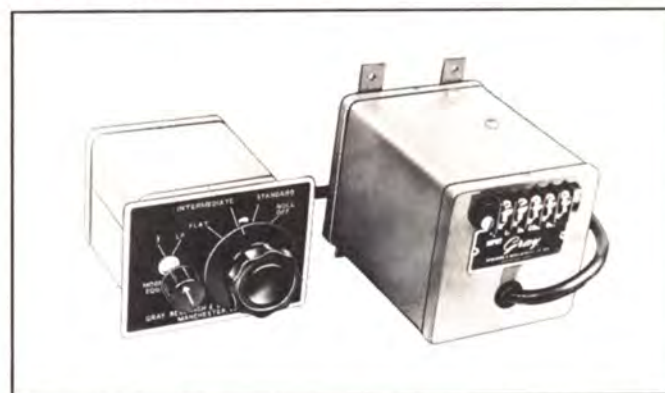

Normally used with standard microphone preamplifiers, making it unnecessary to purchase special audio input equipment when using magnetic cartridges. A convenient control permits instantaneous input switching from conventional records to microgroove.

Output Impedance: 250 ohms balanced (150 or 50 ohms available).

Insertion Loss: 20 db.

Output Level: -67 VU at 4.7 cm/second.

Cable Length: 18" (45.72 kg).

Part No. 272 1438 00

GRAY 212-TN PLAYBACK ARM



A slide-in cartridge is used to allow instant change from standard groove to microgroove. The arm will accommodate all popular magnetic pickup cartridges, including Pickering, G. E., and Fairchild. Available for 12" (212-TN) recordings.

Part No. 099 0386 00

(Type 212-TN)

GRAY 208 SERIES PLAYBACK ARMS



The Gray professional stereo tone arm is available in two models that are identical in performance. Model 208-S comes with a slide and modular weights for mounting single play stereo or monophonic cartridges. Model 208-SG has a special slot cut into the front of the tone arm to clear the stem of a G. E. turnaround cartridge allowing plug-in operation and comes with specific hardware for this application.

Accessory slide kits are available for multiple cartridge operation.

The 8-S accessory slide assembly includes the cartridge slide, modular weights, mounting hardware and impregnable spacers for the installation of stereo or monophonic single play cartridges. The 8-S slide assembly with cartridge mounted is usable in either the 208-S or 208-SG interchangeably.

The 8-SG accessory slide assembly is specifically designed to mount the G. E. turnaround cartridge. With this cartridge installed, it will only fit the 208-SG arm; however, cartridges are interchangeable between arms in this model.

Response: ± 1 db from 5 cps to top end limit imposed by cartridge used.

Size: 21 $\frac{3}{8}$ " W, 2 $\frac{5}{8}$ " H, 15" L (7.46 cm W, 6.67 cm H, 38.1 cm D).

Weight: 2 lbs. (0.91 kg).

Part No. 099 0387 00

(Type 208-S)

Part No. 099 0164 00

(Type 208-SG)

SHURE SERIES 2 PRECISION PICK-UP ARMS MODELS 3009 AND 3012

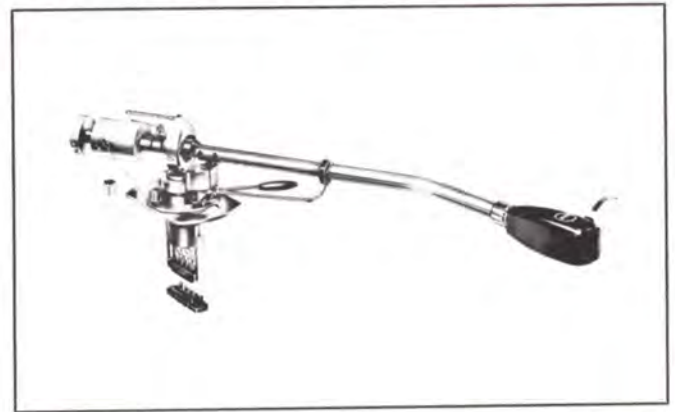

The realism and clarity of a stereo record reflect the skill and technical perfection underlying its manufacture. Only when this is maintained in the reproducing equipment can justice be done to the art of the recording engineers. In playing a phonograph record the stylus must follow a path of extraordinary complexity and be highly compliant if the minute detail of the groove is to be traced without damage. Even the best cartridge cannot achieve this unless it is poised free from extraneous influences. The design of a carrying arm capable of realizing the full potential of pick-up and record is highly specialized involving many problems. These have been successfully resolved in the S.M.E., an instrument of unrivalled quality presented with confidence that the user will endorse the claim 'The best pick-up arm in the world'.

DESIGN FEATURES

Compensation is provided for the force which tries to move a pick-up arm towards the centre of a record. The arm is given an opposing bias, adjustable for various tracking pressures, which balances the stylus centrally in the groove so that it does not favor one wall.

Precision ball races and knife-edge bearings reduce pivot friction to approximately .020 gram measured at the stylus. Cartridges can be used at optimum stylus pressure without the excess weight otherwise required to overcome friction in the pivots.

A carefully chosen offset minimizes distortion due to tracking error.

The tubular tone arm has a wood lining and the bal-

ance system is decoupled by a compliant joint. Resonances are placed where they can have no effect on the recorded range.

The balance system permits accurate longitudinal and lateral balance of cartridges from 5-20 grams weight and tracking pressures from $\frac{1}{4}$ to 5 grams applied precisely without the need for a stylus pressure gauge.

Versatile and quickly aligned for optimum tracking by sliding the base on its graduated bed plate using the protractor included with each arm. Full advantage can be taken of the best present and future cartridges, impracticable with arms of integrated design.

Lever operated raising and lowering control gives automatic slow descent. Fascinating to use—safeguards valuable records.

Choice of tone arm length to suit space available. If the motor board is big enough the 3012 is better, tracking error is even smaller and for studio use 16" records can be played. Otherwise the 3009 can be used with every confidence and indeed is the one most frequently employed.

SHURE STUDIO DYNETIC PHONO REPRODUCER M226/M222/M22

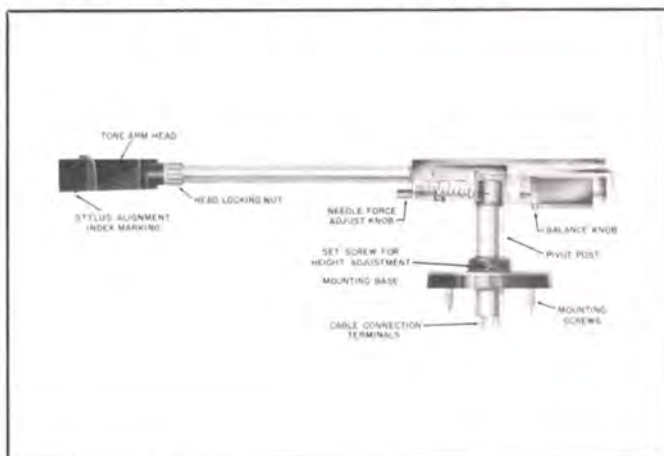

Model M226 Studio Stereo Dynetic reproducer is of the highest quality, employing a new electromagnetic transducer for playing monophonic and stereophonic phonograph records. It is intended to reproduce recordings with needle forces of $\frac{3}{4}$ to $1\frac{1}{2}$ grams practically eliminating record and needle wear. The Model M226 Studio Dynetic is intended for studio and professional use and is capable of reproducing records up to 16" (40 cm.) in diameter. The M222 Studio Dynetic is similar to Model 226, but is intended for use with equipment where space is limited. It is designed to reproduce records up to 12" (30 cm.) in diameter.

The cartridges in the Studio Stereo Dynetic reproducers are of the plug-in type and can be readily removed and replaced. Both models M226 and M222 play stereo discs stereophonically, monophonic discs monophonically and stereo discs monophonically. The Model M22 Stereophonic

Cartridge has a replaceable 0.5 mil (0.018 mm.) radius stylus bearing the Model Number N22.

The needle load in the Studio Stereo Dynetic reproducers is readily adjustable by turning a counter-balance (See Fig. A) visible from underneath the arm. With a high grade turntable and motorboard free of vibrations, the counter-balance may be adjusted as far from cartridge as possible resulting in a $\frac{3}{4}$ gram needle load. Under unsatisfactory conditions of motorboard vibration or when playing records with extremely high modulation, the counter-balance may be set all the way towards the cartridge, resulting in a $1\frac{1}{2}$ gram needle load. The Studio Stereo Dynetic reproducer is available with diamond styli only. To prevent damage, the diamond stylus is packaged in a separate plastic container and should only be installed after mounting the arm.

A magnetic type arm rest designed to harmonize with the appearance of the Studio Stereo Dynetic reproducer, is furnished in the package.

SPECIFICATIONS

Sensitivity: Output at 1000 cycles — 4.5 millivolts ± 2 db per channel on WS-1A Test Record (5 centimeters per second).

Response Frequency Characteristic: From 20 to 20,000 cps ± 2.5 db. (See Fig. C). There is considerable response down to 10 cycles and up to 30,000 cycles per second.

Channel Separation: More than 22.5 db at 1000 cycles per second.

N22D STYLUS

Needle tip material: Diamond.

Needle tip radius: 0.5 mil (0.013 mm.) ± 0.1 mil.

Lateral and vertical needle tip compliance: 22.0×10^6 centimeters per dyne.

Needle tip mass: 0.2 milligram tip mass, 1.1 milligram effective mass.

Tracking force: $\frac{3}{4}$ to $1\frac{1}{2}$ grams — adjustable.

Recommended Load Impedance: 47,000 ohms. Higher values of load impedance will produce a slight increase in high frequency response.

Inductance: 400 millihenries per channel.

D. C. Resistance: 600 ohms per channel.

DIMENSIONS

Overall length: Model M226, $14\frac{3}{4}$ in., 374 mm. Model M222, $11\frac{5}{8}$ in., 287 mm.

Stylus to center of base: Model M226, $11\frac{1}{32}$ in., 279 mm. Model M222, $8\frac{1}{2}$ in., 216 mm.

Base diameter: Model M226, 2 in., 50.8 mm. Model M222, 2 in., 50.8 mm.

Range of height of adjustment: Model M226, $1\frac{5}{8}$ in., 41.3 mm. Model M222, $1\frac{5}{8}$ in., 41.3 mm.

Arm pivot to turntable center: Model M226 $10\text{-}19\text{/}32$ in., 269 mm. Model M222, $8\frac{1}{4}$ in., 210 mm.

Weight: M226, 11.1 ounces (315 g.).

Weight: M222, 10.6 ounces (300 g.).

Packaged Weight: 1 pound, 3 ounces (538 g.).

Replacement Styli:

M22 Cartridge —

Shure N22D Stylus 0.5 mil radius (0.013 mm.).

SHURE PHONOGRAPH CARTRIDGE MODEL M44-7



The Model M44-7 Dynetic Phonograph Cartridge has been developed for use in all high fidelity applications. It has been designed to connect into magnetic and constant velocity inputs.

Recently, highly technical papers have been published in the leading audio journals to the effect that a hitherto "hidden" source of distortion has finally been identified. It was stated that the difference in the effective angles between the record cutting mechanism's chisel point and the angle of the ball point playback stylus led to an annoying, discernible and measurable distortion. A matching of the vertical tracking angle of the playback stylus to the effective angle at which the record has been cut will eliminate this distortion.

Major recording companies have now begun to use a 15° effective cutting angle and it is the proposed E.I.A. standard (similar in practice and effect to the adoption of the RIAA equalization curve).

The M44 Series of Stereo Dynetic Phono Cartridges has been specifically designed to complement the 15° effective cutting angle now being used on the newest recordings. It also serves to significantly improve the sound obtained from older discs.

The M44-7 is completely compatible. It will play Stereo Discs Stereophonically, Monaural Discs Monaurally, and Stereo Discs Monaurally without excessive wear and distortion.

The Model M44-7 utilizes the Moving Magnet principle and features:

- High needle compliance.
- Low needle talk.
- Low tracking force.
- Wide range frequency response.
- Improved shielding for maximum reduction of hum pickup.
- Exceptional ease in changing stylus assembly.
- No magnetic attraction to steel turntables.

SPECIFICATIONS

Frequency Response: From 20 to 20,000 cps.
Output Voltage: 9 millivolts per channel at 1,000 cps.
Channel Separation: More than 25 db at 1,000 cps.

Recommended Load Impedance: 47,000 ohms (per channel).

Stylus Replacement: Model Number N44-7; Radius: .0007" (.018 mm) diamond; stylus grip color: White;
 *See note — Stylus Model Number N44-3; Radius .0025" (.064 mm) diamond; stylus grip color: Green.

Compliance: Vertical-Horizontal, 20.0 x 10⁶ cm/ dyne.

Tracking: 1.5 to 3.0 grams.

Stylus: "No Scratch" Retractable Feature.

Inductance: 680 millihenries.

D. C. Resistance: 650 ohms.

Terminals: 4 terminals (See Figures 2).

Mounting: Standard 1/2" (12.7 mm) mounting center.

Weight: Net Weight: 7 grams. Packaged weight: 5 1/2 ounces (156 grams).

*The N44-3 Stylus may be used in the M44 Dynetic Cartridge to reproduce the standard 78 rpm records. In this case the amplifier should be set to "Monaural" or "A + B." The M44-3 is designed for tracking forces of 1.5 to 3.0 grams.

SHURE PHONOGRAPH CARTRIDGE MODEL M44-5

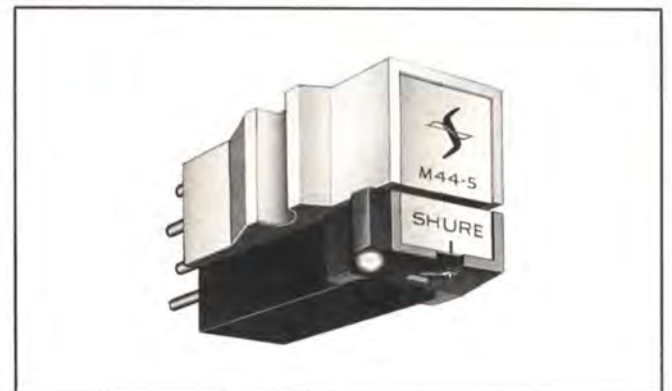

SPECIFICATIONS:

Frequency Response: From 20 to 20,000 cps.

Output Voltage: 6 millivolts per channel at 1,000 cps.

Channel Separation: More than 25 db at 1,000 cps.

Recommended Load Impedance: 47,000 ohms (per channel).

Stylus Replacement: Model Number N44-5; Radius: .0005" (.013 mm) diamond; Stylus grip color: Red;

*See Note — Stylus Model number N44-3; Radius .0025" (.064 mm) diamond; Stylus grip color: Green.

Compliance: Vertical-Horizontal, 25.0 x 10⁶ cm per dyne.

Tracking: 3/4 gram to 1 1/2 grams.

Stylus: "No Scratch" Retractable Feature.

Inductance: 680 millihenries.

D. C. Resistance: 650 ohms.

Terminals: 4 terminals (See Figure 2).

Mounting: Standard 1/2" (12.7 mm) mounting center.

Weight: Net Weight: 7 grams. Packaged weight: 5 1/2 ounces (156 grams).

*The N44-3 Stylus may be used in the M44 Dynetic Cartridge to reproduce the standard 78 rpm records. In this case, the amplifier should be set to "Monaural" or "A + B." The N44-3 is designed for tracking forces of 1.5 to 3.0 grams.

**SHURE PHONOGRAPH CARTRIDGE
MODELS M5D AND M6S**

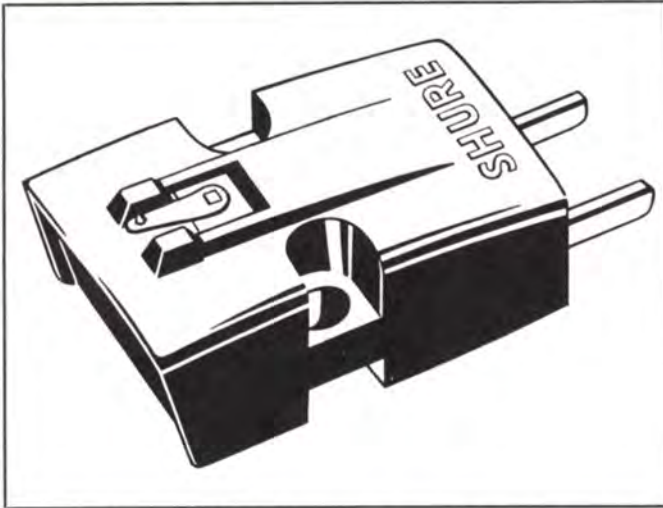

The M5 and M6 Professional Dynetic Cartridges have been developed specifically for use in custom high fidelity sets, record changers, and transcription arms. These cartridges have been designed to connect into magnetic and constant velocity inputs.

This new electromagnetic transducer utilizes the same Dynetic principle employed in the Studio Dynetic Cartridge and tone arm assembly. This new electro-mechanical principle uses a moving magnet which provides extreme linearity and freedom from distortion. Since the magnet turns on its vertical axis, it is possible to place the needle tip at the end of a light metallic beam, providing very low needle point mass. The stylus assembly is held in a durable elastomer composition which provides high needle compliance. Vertical compliance at the needle tip is excellent. Because of these factors, needle talk is practically nonexistent. Other important features are:

1. Needle replacement is exceptionally simple and fast. No tools are required.
2. Magnetic induction from external hum fields is reduced to a minimum.
3. No magnetic attraction to steel turntables.

SPECIFICATIONS — MODEL M5D

Use: Microgroove, 33-1/3 — 45 R.P.M.
Stylus Radius: 1 Mil (0.025 mm) Diamond.
Stylus No.: N5D.
Stylus Color Coding: Black Dot.

SPECIFICATIONS — MODEL M6S

Use: Standard 78 R.P.M.
Stylus Radius: 2.7 Mil (0.069 mm) Synthesized Sapphire.
Stylus No.: N6S.
Stylus Color Coding: Yellow Dot.

Response Frequency Characteristic: From 20 to 20,000 cps (See Fig. 1) designed to ideally meet the exacting requirements of typical high fidelity reproduction.

Output Voltage: Output at 1000 cycles 21 millivolts for 10 centimeters per second.

Recommended Load Impedance: 27,000 ohms. Higher values will produce a slight increase in high frequency response.

Compliance: 3.0×10^6 centimeters per dyne.

Tracking Force: 3 to 6 grams.

Inductance: 350 millihenrys.

D. C. Resistance: 440 ohms.

Weight: .44 ounces (12.4 g.).

Packaged Weight: 3.3 ounces (95 g.).

SHURE PLAYBACK ARMS

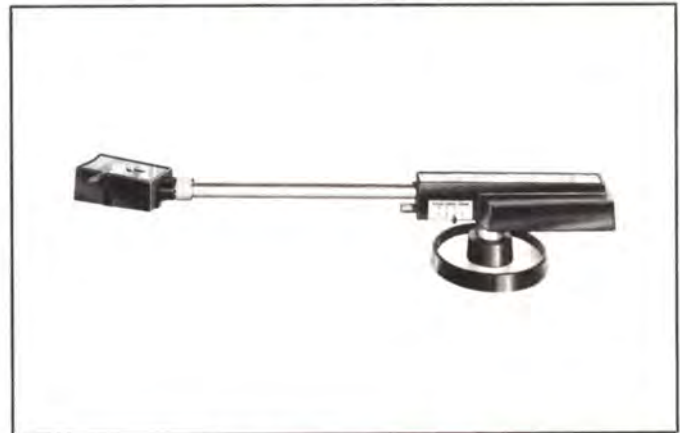

Accepts stereo and monophonic cartridges. Arm features precision ball bearings at all pivot points, plug-in head with positive alignment lock and variable adjustment. Supplied with arm rest, mounting template, mounting hardware and 4-foot cable assembly.

Size and Weight: 12" arm (M232), 12 1/4" L, 1 lb. (0.45 kg); 16" arm (M236), 14 1/2" L, 1 1/8 lbs. (0.48 kg).

Part No. 097 8118 00
 Part No. 097 8122 00

(Type M232)
 (Type M236)

REK-O-KUT PLAYBACK ARMS



Tubular arm body with die cast aluminum cartridge shell and counterweight. Four-conductor lead accommodates all 3- and 4-wire stereo cartridges. Does not include but uses all standard cartridges. Available for either 16" (S-260) or 12" (S-320) recordings.

Part No. 099 0242 00
 Part No. 099 0241 00

(Type S-260)
 (Type S-320)

GENERAL ELECTRIC CARTRIDGES AND STYLI



- 4GS-01D — Cartridge with 1 mil diamond stylus.
- 4GS-02D — Cartridge with 2.5 mil diamond stylus.
- 4GS-01S — Cartridge with 1 mil sapphire stylus.
- 4GS-02S — Cartridge with 2.5 mil sapphire stylus.
- 4GD-01D-02S — Cartridge with 1 mil diamond and 2.5 mil sapphire styli.
- 4GD-01D-02D — Cartridge with 1 and 2.5 mil diamond styli.
- 4GD-01S-02S — Cartridge with 1 and 2.5 mil sapphire styli.
- 4G-01D — 1 mil Diamond Stylus (above cartridges only).
- 4G-02D — 2.5 mil Diamond Stylus (above cartridges only).
- 4G-01S — 1 mil Sapphire Stylus (above cartridges only).
- 4G-02S — 2.5 mil Sapphire Stylus (above cartridges only).

Part No. 097 3844 00	(Type 4GS-01D)
Part No. 097 3845 00	(Type 4GS-02D)
Part No. 097 3846 00	(Type 4GS-01S)
Part No. 097 3847 00	(Type 4GS-02S)
Part No. 097 3848 00	(Type 4GD-01D-02S)
Part No. 097 3849 00	(Type 4GD-01D-02D)
Part No. 097 3850 00	(Type 4GD-01S-02S)
Part No. 097 3853 00	(Type 4G-01D)
Part No. 097 3854 00	(Type 4G-02D)
Part No. 097 3851 00	(Type 4G-01S)
Part No. 097 3852 00	(Type 4G-02S)

COLLINS 642A-2 AND 216C-2 TAPE CARTRIDGE SYSTEM

Tape cartridge programming with Collins equipment means perfection in recording and playback. Stored in 40-second to 31-minute endless tape cartridges, programs are conveniently and safely stored until air time. Then, the cartridge is inserted into the playback deck, one button pressed, and the program is on the air, on cue.

The ease of programming is only a feature of convenience to the broadcaster. The degree of perfection in cueing spot announcements and the resulting tight production are features the listening audience can observe as a mark of the truly professional broadcaster.

Cueing the tape with Collins equipment is an automatic process not dependent upon human skills. A fraction of a second before the start of the recording process

on the upper half of the tape, a tone burst is recorded on the bottom half of the tape. This tone burst automatically stops the endless tape during the playback operation so that there is less than a 0.1-second start time for the next play.

The tone burst recorded on the tape automatically re-cues the tape for the next play. The playback units contain the necessary relay switching to automatically switch audio feed from an unlimited number of units into a single input of the speech input console. When any unit is started, all others are automatically disconnected from the line. Any unit that is running when another unit is started will continue to run until it is cued to the start position or is manually stopped. A second cue tone can be inserted anywhere on the tape. This is used to trigger the next playback unit or to operate remote equipment.

The cartridge is inserted along a guide and under a sturdy retaining spring which keep the entire cartridge firmly in place. Pressure pads within the cartridge hold the tape flat and firmly against the record/playback head and cue head. A precision gap of 0.00020 of an inch in the record/playback head provides resolution of the complete audio range at the 7½-inch tape speed. The heads are built on laminated cores, which permit high recording levels without danger of core saturation. The laminated cores and the balanced double coil winding result in a signal-to-noise ratio of 55 db or better as measured by the proposed NAB standard of 400 cps at 3% THD.

The capstan pressure roller, pivoting 90° from below the deck surface, snaps into position to hold the tape securely against the driving capstan. The tension of this roller is easily adjustable. The pressure roller resists wear and is accurately ground so that the tape is not fluted or stretched as it passes between the capstan and the pressure roller.

Pulling the pressure roller into position is a heavy duty solenoid guaranteed to last. This solenoid was activated over 2-million times in the Collins Quality Control laboratories and showed no appreciable wear. Activation of the solenoid and pressure roller is a fast, light operation. Shimmy and vibration are not present.

Mounted on a strong and accurately machined aluminum deck, the mechanical portions of the Collins playback and recorder units are guaranteed to stay in perfect alignment. The precision of the playback and record heads in relation to the capstan, solenoid-activated linkage system and flywheel requires more than a pressed mounting plate. The Collins deck has a cast structural reinforcement so that alignment of all moving parts is always perfect.

Driving the unit is a heavy duty-Bodine synchronous motor with vertical ball thrust bearing. The motor is energized by inserting a tape cartridge. The life and low wear of the motor are features second only to the steady speed. The tape is moved through the unit at 7½ inches per second with 99.6% accuracy.



642A-2 TAPE CARTRIDGE SYSTEM

The motor is coupled to the flywheel with three resilient drive belts. This indirect drive, found in premium grade tape equipment, features much greater driving torque than in direct drive capstan systems. This torque is a must for syllable-splitting cueing required by present day broadcasting standards.

The machined and highly polished solid brass flywheel is typical of Collins precision. The flywheel and capstan, with two Oilite lateral bearings and a ball thrust vertical bearing, are virtually wearproof and maintain their equal balance. The result is very important: the playback unit holds flutter and wow to less than 0.2 of 1% RMS.

The units are finished in a blue-gray baked enamel, and extenders are furnished for rack mounting or other 19" width mounting requirements. The following specifications apply to both the 216C-2 Record and 642A-2 Playback Units:

Power Source: 105-125 v ac, 60 cps (50 cps model available on order), single phase.

Frequency Response: ± 2 db 50-12,000 cps, ± 4 db 50-15,000 cps, with 1,000 cps reference frequency.

Harmonic Distortion: 2% or less at 0 VU record level.

Signal-to-Noise Ratio: 45 db or better at 400 cps.

642A-2 PLAYBACK SPECIFICATIONS

Power Consumption: 100 watts during operation, 25 watts standby.

Gain: 55 db at 1,000 cps.

Size: 15" or 19" W, 8 $\frac{3}{4}$ " H, 13 $\frac{3}{4}$ " D (38.1 cm or 48.26 cm W, 22.23 cm H, 34.93 cm D).

Weight: 40 lbs. (18.15 kg).

Part No. 522 3497 00 (Type 642A-2 Playback)

216C-2 RECORD SPECIFICATIONS

Power Consumption: 125 watts.

Audio Inputs: Microphone and line, both variable gain and capable of being mixed. Microphone input 250 ohm impedance (50/600 ohms optional.) Will accommodate input levels from -65 dbm to -35 dbm. Line input 600 ohm impedance (50/250 ohms optional). Will accommodate levels from -15 dbm to +10 dbm.

Cueing: Primary tune, 1000 cps. Secondary tune, 350 cps.

Size: 15" or 19" W, 7" H, 13 $\frac{3}{4}$ " D (38.1 cm or 48.26 cm W, 17.78 cm H, 34.93 cm D).

Weight: 15 lbs. (6.8 kg).

Part No. 522 3496 00 (Type 216C-2 Record)

COLLINS DESK WING CONSOLE

Functional and economical unit for housing three 15" Collins automatic programming playback units (or two playback units and one record unit) and 120 of the Series 300 tape cartridges. Sturdy construction and wear resistant Formica finish in walnut (DWW-3). Other finishes available on request.

Size: 51" W, 30" H, 18" D. (129.5 cm W., 76.2 cm H., 45.72 cm D).

Weight: 150 lbs. (68.04 kg).

Part No. 097 5350 00

COLLINS PRODUCTION CONSOLE CABINET



Complete Collins automatic programming recording and playback facilities may be mounted in this cabinet. Houses one 15" playback and one 15" recording amplifier. Has cutout for one 8" speaker (not included). Walnut Formica finish. Other finishes available on request. Size: 18" W, 34" H, 24" D (45.72 cm W, 86.36 cm H, 60.96 cm D).

Weight: 85 lbs. (38.36 kg).

Part No. 097 7522 00

COLLINS TAPE CARTRIDGE RACK

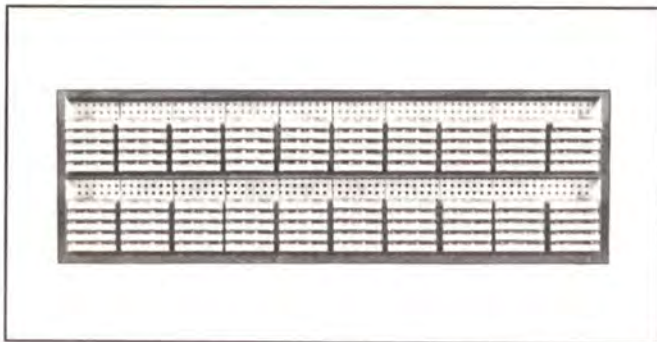

Formica covered wood rack holds 120 of the Series 300 cartridges used with Collins automatic programming equipment. Four rubber cushions allow rack to be set on top of programming wing. It also may be hung on wall. Walnut Formica. Other finishes available on request. Size: 45 $\frac{3}{4}$ " W, 14 $\frac{3}{8}$ " H, 4" D (116.21 cm W, 36.51 cm H, 10.16 cm D).

Weight: 25 lbs. (11.34 kg).

Part No. 097 5727 00

ABCO LAZY SUSAN CARTRIDGE RACK

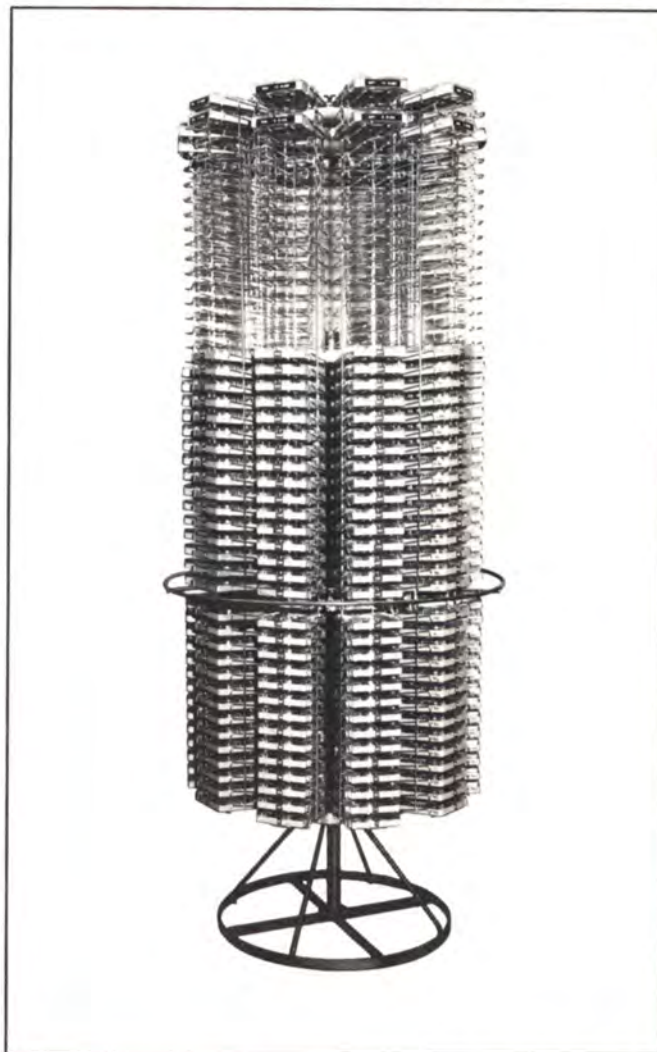

This sturdy, heavy Lazy Susan rack holds 500 of the Series 300 Collins automatic programming equipment tape cartridges. Ten chrome-plated racks with 50 slots each make storage and selection of cartridges fast and simple. Revolves easily on roller bearing hub and will not tip regardless of arrangement of cartridges. Cartridges held in wire holders at an angle to prevent slipping out while the rack is being revolved. Shipped knocked down.

Size: Approx. 72" H, 36" diameter (182.88 cm H, 91.44 cm diameter).

Weight: Approx. 50 lbs. (22.68 kg).

Part No. 097 7559 00

ABCO WIRE CARTRIDGE RACK

Individual wire rack holding 50 Collins automatic programming equipment cartridges. Identical rack to those used in the Lazy Susan. Includes tapped mounting brackets welded to wire rack.

Size: Approx. 5" W, 11 $\frac{1}{2}$ " H, 7" D (12.7 cm W, 3.81 cm H, 17.78 cm D).

Weight: Approx. 2 lbs. (0.91 kg).

Part No. 097 7560 00

COLLINS 313T-4 REMOTE CONTROL PANEL



Three Collins automatic programming playback units, in addition to a record/playback system, may be operated with this control panel from a remote point in the broadcast studio. Buttons illuminate when in operation.

Size: 5 1/8" W, 2 3/4" H, 4 1/2" D (13.02 cm W, 6.99 cm H, 11.43 cm D).

Part No. 522 2552 00

COLLINS 313T-3 REMOTE CONTROL PANEL



Has three illuminated "start" buttons for control of three or less playback units from a remote point.

Size: 5 1/8" W, 4 1/2" H, 4 1/2" D (13.02 cm W, 11.43 cm H, 11.43 cm D).

Part No. 522 2551 00

COLLINS 313T-1 REMOTE CONTROL PANEL



Has illuminated "start," "record" and "stop" buttons for control of one record/playback system from a remote point.

Size: 5 1/8" W, 2 3/8" H, 4 1/2" D (13.02 cm W, 6.99 cm H, 11.43 cm D).

Part No. 522 2550 00

COLLINS AUTOMATIC PROGRAMMING LOADED CARTRIDGES

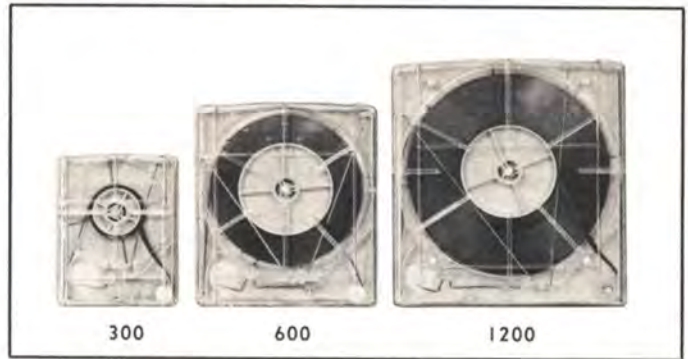

Manufactured for Collins automatic programming equipment, these cartridges are loaded with fine quality, specially lubricated tape.

300 Series: Loaded cartridges packed six per box (minimum one box) in following lengths: 40, 70, 90, 100 seconds; 2 1/2, 3, 3 1/2, 5, 5 1/2, 7, 7 1/2, 10, 10 1/2 minutes. Specify length.

Type No.	Part Number	Length
300 Series	099 1393 00	40 Second Tape Cartridges
300 Series	099 1394 00	70 Second
300 Series	099 1993 00	90 Second
300 Series	099 1399 00	100 Second
300 Series	099 1500 00	2 1/2 Minute
300 Series	099 1592 00	3 Minute
300 Series	099 1395 00	3 1/2 Minute
300 Series	099 1593 00	5 Minute
300 Series	099 1396 00	5 1/2 Minute
300 Series	099 1994 00	7 1/2 Minute
300 Series	099 1995 00	10 Minute
300 Series	099 1397 00	10 1/2 Minute

600 Series: Loaded cartridges packed two per box (minimum one box) in following lengths: 11, 13 1/2, 15, 16 minutes. Specify length.

600 Series	099 1996 00	11 Minute
600 Series	099 1997 00	13 1/2 Minute
600 Series	099 1998 00	15 Minute
600 Series	099 1999 00	16 Minute

1200 Series: Loaded cartridges packed two per box (minimum one box) in 31 minute lengths.

1200 Series	099 1398 00	31 Minute
-------------	-------------	-----------

COLLINS AUTOMATIC PROGRAMMING BLANK CARTRIDGES

Identical to above cartridges for custom loading.

300 Series: Blank cartridges packed six per box (minimum one box). Up to 10 1/2 minutes playing time.

Part No. 099 1594 00

600 Series: Blank cartridges packed two per box (minimum one box). From 11 to 16 minutes playing time.

Part No. 099 2302 00

1200 Series: Blank cartridges packed two per box (minimum one box). From 16 1/2 to 31 minutes playing time.

Part No. 099 1900 00

COLLINS AUTOMATIC PROGRAMMING MM-151 BULK RECORDING TAPE

A fine quality, specially lubricated, Minnesota Mining tape in bulk lengths of 1,700' on 7" reels for use with Collins Automatic Programming blank cartridges.

Part No. 097 2629 00

AUDIOTAPE AND MM RECORDING TAPES

The following tapes are designed for conventional recorders (see description under Collins Automatic Programming MM-151 Bulk Recording Tape for specially lubricated bulk tape):

1251: Audiotape, 1200 ft., 7" reel.

1861: Audiotape, Mylar, 1800 ft., 7" reel.

111A-6: Minnesota Mining tape, 600 ft., 5" reel.

111A-12: Minnesota Mining tape, 1200 ft., 7" reel.

150-18: Minnesota Mining tape, Mylar, 1800 ft., 7" reel.

190-18: Minnesota Mining tape, plastic base, 1800 ft., 7" reel.

Part No. 097 2039 00	(Type 1251)
Part No. 097 2992 00	(Type 1861)
Part No. 272 1408 00	(Type 111A-6)
Part No. 272 1407 00	(Type 111A-12)
Part No. 097 7112 00	(Type 150-18)
Part No. 099 0040 00	(Type 190-18)

REEVES ST-466 BULK SPLICING TAPE

Reeves splicing tape for use with Collins Automatic Programming equipment recording tape. Mylar 11½ mil tape 7/32" wide and supplied in 66' roll.

Part No. 099 0496 00

ROBINS TS4-DLX SPLICER-CUTTER



Used for magnetic recording tape, this unit cuts two rounded indentations in the tape splice, giving the splice a "Gibson Girl" shape and leaving the edges of the tape free of adhesive. The unit can be removed from its base and mounted directly on any tape recorder. It comes complete with a roll of splicing tape and tape feed.

Part No. 097 2058 00

COLLINS AUTOMATIC PROGRAMMING TEST TAPE

Azimuth head alignment test tape for Collins automatic programming playback in 70-second length with 5,000 cps tone on cue track and 10,000 cps tone on program track.

Part No. 097 6076 00

REPLACEMENT PRESSURE PADS

Long lived Polyurethane pad interchangeable with pads in original cartridge in boxes of 50.

Part No. 094 2546 00

TAPE CARTRIDGE REPAIR KIT

Collins Automatic Programming cartridges may be repaired easily with this repair kit which includes 12 Teflon washers, 12 pressure pads and 12 center screws.

Part No. 099 0066 00

Minimum order of three kits as described above.

MAGNERASER 200C TAPE ERASER



A compact and convenient bulk tape eraser that removes recorded signals from tape up to 35 mm in size and lowers background noise level up to 6 db below that of unused tape. A pushbutton safety switch prevents current from being applied when not in use.

Operating Voltage: 100-130 v, 50-60 cps.

Size: 2" H, 4" diameter (5.08 cm H, 10.16 cm diameter).

Weight: 2½ lbs. (1.13 kg).

Part No. 097 5172 00

MICROTRAN HD-11M TAPE ERASER



A bulk tape demagnetizer that develops a high intensity magnetic field to erase signals and noise without rewinding. Spindle mounting of reel permits rapid and thorough coverage.

Reel Size Range: 5", 7", 10½" (spindle removable for use with other size reels).

Adapter Hub: Available for use with 10½" reels.

Rating: 117 v ac, 5 amps.

Size: 5" W, 3" H, 8" D (12.7 cm W, 7.62 cm H, 20.32 cm D).

Part No. 099 0371 00

AMPEX 602 SERIES RECORDER

The 602 is a field recorder that will go where you go — and give you the reliability and professional studio-quality you need when you get there! The 602 series units have hysteresis synchronous drive motors and three separate heads: erase, record, and playback. For rack mounting in the studio, it uses minimal rack space.

SPECIFICATIONS/602 SERIES

Measured by professional standard methods. These are the guaranteed minimum specifications the user can expect in long-term operation.

Frequency Response: 40 to 15,000 cps; down no more than 4 db at 15,000; ± 2 db from 40 to 10,000 cps at $7\frac{1}{2}$ ips. $3\frac{3}{4}$ ips model $+2 -4$ db from 40 to 8,000 cps.

Signal-to-Noise Ratio: Model 602-1: with full track head, over 57 db; with half-track head, over 55 db. Model 602-2: over 55 db. All at $7\frac{1}{2}$ ips.

Flutter and Wow: Less than 0.17% at $7\frac{1}{2}$ ips; less than 0.25% at $3\frac{3}{4}$ ips (measured at ASA standard).

Timing Accuracy: $\pm 0.2\%$ at $7\frac{1}{2}$ ips (± 3.6 seconds in a 30 minute recording).

Fast Forward or Fast Rewind Time: 90 seconds for full 1200-foot reel.

Heads: Three separate heads: erase, record, playback.
 Model 602-1: Full-track or half-track
 Model 602-2: Two-track heads

Speeds: $7\frac{1}{2}$ ips model or $3\frac{3}{4}$ ips model.

Reel Size: 7" and 5".

Inputs (each channel): Two inputs, individual gain controls on each.

- low impedance mike input, 150 microvolts required for program record level (for use with mikes of 30 to 250 ohms nominal impedance).
- Line input (100K unbalanced), — 10 dbm required for program record level.

All inputs are Cannon XL connectors. Provision for use of plug-in balanced line or bridging input transformers.

Line input can be used as input for second microphone by accessory plug-in preamplifier (allowing 2 microphones to be mixed on one channel).

Outputs (each channel): a. +4 dbm into 600 ohm. Balanced or unbalanced load.

b. Head phone jack (on front panel).

Monitor selector knob permits monitoring from either the input source or the tape playback, while recording.

Equalization: For 117 volt, 50 and 60 cps models: $7\frac{1}{2}$ ips, NAB; $3\frac{3}{4}$ ips, 120 microsecond.

For 115/230 volt, 50 cps models: $7\frac{1}{2}$ ips (19 cm/s), CCIR; $3\frac{3}{4}$ ips (9.5 cm/s) 200 microsecond.

Power Requirements: Models for 117 v., 60 cps; 117 v., 50 cps; 115/230 v., 50 cps. Model 602-1, 70 volt-amperes; Model 602-2, 105 volt-amperes.

Weight (in case): Model 602-1: 28 lbs. Model 602-2: 42 lbs.

U. L. Approved

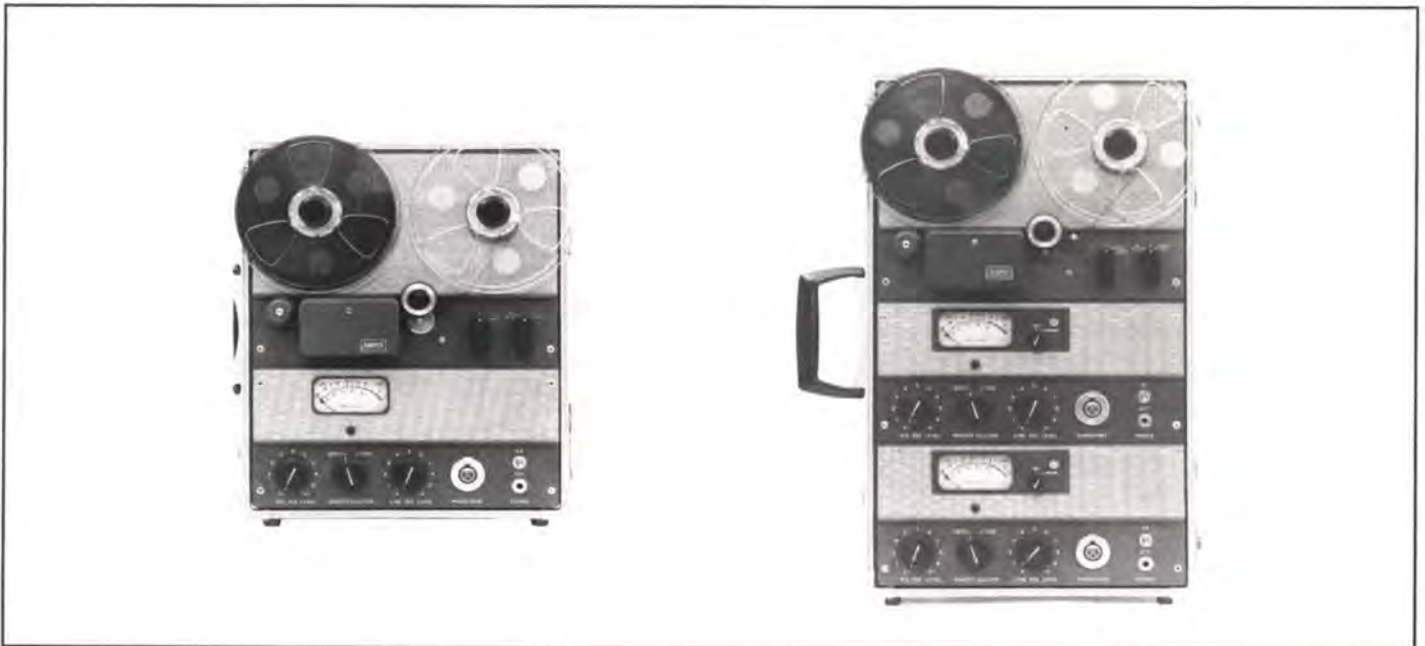

AMPEX 602-1 ONE CHANNEL RECORDER

You may choose full or half-track heads. A rugged, dependable recorder that will meet your performance requirements for a professional mono input.

Portable: $7\frac{1}{2}$ ips, half-track head, 602-01; $7\frac{1}{2}$ ips, full-track head, 602-02. $3\frac{3}{4}$ ips, half-track head, 602-17.

Uncased: $7\frac{1}{2}$ ips, half-track head, 602-03. $7\frac{1}{2}$ ips, full-track head, 602-04.

AMPEX 602-2 TWO CHANNEL RECORDER

The 602-02 provides two-track heads with selective-track erase head; two electronic channels, give you the versatility of two-track stereo and half-track mono in one unit.

Portable: $7\frac{1}{2}$ ips, two-track head, 6022-01. $3\frac{3}{4}$ ips, two-track head, 6022-07.

Uncased: $7\frac{1}{2}$ ips, two-track head, 6022-02.

AMPEX 622 SPEAKER/AMPLIFIER



The 622 unit gives you "on-the-spot" studio-quality playback for demonstration or monitoring. Its 10 watt amplifier provides ample volume for a medium size auditorium.

SPECIFICATIONS/622 SPEAKER-AMPLIFIER

Overall Frequency Response (in air): Essentially flat acoustically, range better than 65-10,000 cps.

Speaker Size: Special design 8" full-range speaker.

Power Output: 10 watts amplifier power with no audible harmonic distortion. Speaker can handle full power.

Signal-to-Noise: Amplifier noise (including hum), 70 db below rated output.

Controls & Connections: Volume control, bass-treble control, power switch and on-off indicator light. Built-in AC convenience outlet. Audio input connector is concentric pin type. External speaker connection is head-telephone type jack.

Equalization: Single control on front panel provides adjustment, boosting bass and attenuating treble or vice versa. Maximum bass boost 6 db relative to treble. Maximum treble boost 6 db relative to bass.

External Speaker Feed: Use of "SPEAKER" jack automatically cuts out the 622's internal speaker and reciprocal network. Flat amplifier output is fed to the external speaker.

Impedance: Inputs, 100,000 ohms. Output, 12 ohms to external speaker.

Power Requirement: 117 volts, 50 or 60 cycles, 0.5 amps, 55 watts.

Weight: 25 pounds.

U. L. Approved

DIMENSIONS/602-1 602-2 622

Transport top area: 9 1/8" x 12 1/2".

Electronic top area: 6 1/8" x 12 1/2".

(two electronic sections in Model 602-2).

Depth below top plate: 5".

Overall size, include carrying case:

Model 602-1; 8" x 13 3/4" x 16 1/2"

Model 602-2; 8" x 13 3/4" x 23"

Rack Space: will mount in standard 19" width rack, with appropriate Ampex adapter panel.

Model 602-1 with #864 Adapter Panel, takes only 17 1/2" of vertical rack space.

Model 602-2 with #865 Adapter Panel, takes only 23 3/4" of vertical rack space.

Model 622 speaker/amplifier, overall size in carrying case: 13" x 16" x 8".

Part No. 099 2484 000

ACCESSORIES FOR AMPEX 602 SERIES

	Order By Type Number
Minor Hardware Kit	897
Portable case —	
for 602-1 one-channel model	854
for 602-2 two-channel model	855
Rack Mount Adapter — for 602-1	864
for 602-2	865
Operation & Maintenance Manual (602 series)	89-0080
Operator's Guide for 622 Amplifier/Speaker	89-0099
Professional Accessory Kit (includes head cleaner, demagnetizer, motor oil, Q-tips)	894
Head Demagnetizer	820
Head Cleaner, 4-oz. Can	823
Lubricating Oil, approved, in plastic oiler bottle	825
Alignment Tapes (see separate Alignment Tape Price Schedule and descriptions). Speed and power frequency conversion kits available on request from Ampex Service Engineering Department.	

AMPEX 350 SERIES RECORDER

A complete family of professional audio recorders and reproducers featuring the basic 350 tape transport, one of the most dependable transports ever built.

The 350 line offers you a wide choice of mounting configurations, head stacks and speeds, to enable you to select the specific instrument for your requirements.

AMPEX 351 1-CHANNEL (MONOPHONIC) RECORDER/REPRODUCER



This is the unit you will find in practically every radio station. It is the standard of the broadcast industry. Avail-

able in full-track or half-track models. Electronics and electronic control panel are in a completely separate chassis from the tape transport. Specifications listed under 351-2.

AMPEX 351-2 2-CHANNEL (STEREOPHONIC) RECORDER/ REPRODUCER

Two 351 single-channel electronics are used with bias oscillator interlock, but retaining all individual controls. Two track heads with separate erase for each channel. Also available with optional four-position head assembly, which includes a quarter-track reproduce head.

SPECIFICATIONS

Tape Speeds: 7½ and 15 ips or 3¾ and 7½ ips.

Frequency Response: Overall Response: 15 ips ±2 db 30-18,000; 7½ ips ±2 db 40-10,000, ±4 db at 30 cps and 15 kc; 3¾ ips ±2 db 50-7,500.

Heads: 351: Half, or full-track erase, record and playback. 351-2: Two-track erase, record and playback. 4-position head assembly available, includes quarter track reproduce head.

VU Meters: Two 4½-inch professional meters, each on separate chassis.

Signal-to-Noise Ratio: 15 ips: Full track, 60 db; Half track, 55 db; 2 Channel stereo, 55 db.

7½ ips: Full track, 60 db; Half track, 55 db; 2 Channel stereo, 55 db.

3¾ ips: Full track, 50 db; Half track, 50 db; 2 Channel stereo, 50 db.

Flutter Content: 15 ips: Well below 0.11%; 7½ ips: Well below 0.14%; 3¾ ips: Well below 0.18%.

Start/Stop: Start: Tape accelerates to full speed in less than 1/10 second. Stop: At 15 ips speed, tape moves less than two inches after pressing "Stop" button.

Playback Timing Accuracy: ±0.2% (±3.6 seconds in a thirty minute recording).

Recording Channel Selector: Two pushbuttons.

Record Input: Suitable to any one of three input terminations: (a) microphone level, 150 to 250 ohms nominal, 200 microvolts required to produce the recommended operating level, may be strapped for 30 to 50 ohms nominal; (b) balanced bridging, 200 K ohms input impedance, -10 dbm required to produce the recommended operating level; (c) unbalanced bridge, 100 K ohms input impedance, -10 dbm required to produce the recommended operating level.

Equalization: All standard models supplied with NAB equalization. AME or CCIR curves available on special order. UNIVERSAL versions contain switchable NAB/CCIR equalization.

Electronic Adjustments: Accessible from rear of chassis.

Playback Output: Plus 8 dbm output into 600 ohms, balanced or unbalanced. Overload margin is maintained by providing a maximum output of +28 dbm before clipping. Can be connected for +4 dbm by restrapping and recalibration.

Power Requirements: Single channel models require 2.0 amperes current; two channel models require 2.5 amperes. Standard models are 117 volts. Universal Series models have built-in multiple tapped power transformer for power input through two ranges: 90 to 130 volts a.c. and 200 to 240 volts a.c., 14 selections. Models available for either 50 or 60 cycles.

Dimensions/Weights: Standard 19 inch wide panels with commercial notching for rack mounting. TAPE TRANSPORT, 15¾ inches of rack space, weight . . . 50 lbs. ELECTRONIC ASSEMBLY, 7 inches of rack space, weight . . . 18 lbs. (two electronics assemblies required for 2 channel stereo). CONSOLE for 351, 48 inches high x 24½ inches wide x 28½ inches deep, weight . . . 168 lbs.

Mounting Configurations: 351: Portable, unmounted, console. 351-2: Portable, unmounted.

Special Versions: Other speeds, 3-speed motors, special head configurations and wider frequency bands, available on special order.

Warranty: Ampex 4-Star 1-Year Warranty.

AMPEX 352 1-CHANNEL (MONOPHONIC) REPRODUCER ONLY

Contains playback facilities only . . . protects irreplaceable tape recording from accidental erasure. Full-track reproduce head. Half-track on special order.

AMPEX 352-2 2-CHANNEL (STEREOPHONIC) REPRODUCER ONLY

Same as the 352 but with dual playback electronics and two-track reproduce head. Also available with optional additional head for quarter-track playback to reproduce four-track stereo tapes.

SPECIFICATIONS

Tape Speeds: 7½ and 15 ips.

Frequency Response: Playback Response; measured with Ampex standard alignment tape 15 ips ±2 db 30-15,000; 7½ ips ±2 db 40-10,000, ±4 db at 15 kc.

Heads: 352: Full-track reproduce (half-track on special order). 352-2: Two track reproduce (Quarter track reproduce also available).

VU Meters: None.

Signal-to-Noise Ratio: 15 ips: Full track, 60 db; 2 track stereo, 55 db.

7½ ips: 2 track stereo, 55 db.

Flutter Content: Same as 351 Series.

Start/Stop: Same as 351 Series.

Playback Timing Accuracy: Same as 351 Series.

Recording Channel Selector: None.

Record Input: None.

Equalization: Same as 351 Series.

Electronic Adjustments: Accessible from rear of chassis.

Playback Output: Same as 351 Series.

Power Requirements: Same as 351 Series.

Dimensions/Weights: TAPE TRANSPORT, 15¾ inches of rack space, weight . . . 50 lbs. ELECTRONIC ASSEMBLY, 5¼ inches of rack space, weight . . . 13½ lbs. POWER PANEL, 1¾ inches of rack space, weight . . . 1 lb. CONSOLE DIMENSIONS, 35 inches high x 24¼ inches wide x 24¾ inches deep, weight . . . 109 lbs.

Mounting Configuration: 352: Unmounted, console. 352-2: Unmounted, console.

Special Versions: Same as 351 Series.

Warranty: Ampex 4-Star 1-Year Warranty.

AMPEX 354 2-CHANNEL (STEREOPHONIC) RECORDER/REPRODUCER



Its two electronic channels are combined into one compact unit. Fits into same space required for a single-channel electronics. Two-track heads with separate erase for each channel. Also available with optional four-position head assembly, which includes a quarter-track reproduce head.

SPECIFICATIONS

Tape Speeds: 7½ and 15 ips or 3¾ and 7½ ips.
Frequency Response: 15 ips ±2 db 30-18,000; 7½ ips ±2 db 40-12,000, ±4 db, 30-15,000; 3¾ ips ±2 db 40-6,000, +2 -4 db 40-8,000.
Heads: 354: Two-track erase, record and playback; 4-position head assembly available, includes quarter track reproduce head.
VU Meters: Two 2½-inch professional meters side by side for easy comparison and balancing of channels.
Signal-to-Noise Ratio: 15 ips: 55 db; 7½ ips: 55 db; 3¾ ips: 50 db.
Flutter Content: Same as 351 Series.
Start/Stop: Same as 351 Series.
Playback Timing Accuracy: Same as 351 Series.
Recording Channel Selector: Selector Switch.
Record Input: Unbalanced bridge, 100 K ohms input impedance, -14 dbm required to produce the recommended operating level. Accessories available to convert input: (a) balanced bridging input transformer, 20,000 ohms input impedance, 1 db insertion loss; (b) microphone preamplifiers, 150 to 200 ohm nominal impedance. Two versions are available, 40 db gain or 60 db gain.

Equalization: All standard models supplied with plug-in NAB equalization units. Plug-in equalizers for AME or CCIR curves available as accessories.

Electronic Adjustments: Accessible: front of electronics panel.

Playback Output: Plus 4 dbm output into 6000 ohms, balanced or unbalanced. Overload margin is maintained by providing a maximum output of +22 dbm before clipping.

Power Requirements: Same as 351 Series, except 354 Series not available in Universal models.

Dimensions/Weights: Standard 19 inch wide panels with commercial notching for rack mounting. TAPE TRANSPORT, 15¾ inches or rack space, weight . . . 50 lbs. ELECTRONIC ASSEMBLY, 7 inches of rack space, weight . . . 30 lbs. PORTABLE WEIGHT: 103 lbs. in two cases. CONSOLE, 48 inches high x 24½ inches wide x 28½ inches deep, weight . . . 155 lbs.

Mounting Configurations: 354: Portable, unmounted, console.

Special Versions: Same as 351 Series.

Warranty: Ampex 4-Star 1-Year Warranty.

MAGNECORD 1028 RECORDER-REPRODUCER



The Magnecord 1028 has advanced circuit design, utilizing latest tube types, and printed wiring to insure uniform high performance from recorder to recorder.

SPECIFICATIONS:

Tape Speeds: 7.5 and 15 inches per second.
Flutter and Wow: 0.15% at 7.5 ips; 0.1% at 15 ips.
Timing Accuracy: ±0.2%.
Reel Size: 5-, 7- and 10½-inch.
Rewind Time: 2400 feet, less than 100 seconds.
Frequency Response: ±2 db — 40 to 16,000 cps at 7.5 ips; 40 to 22,000 cps at 15 ips.
Signal-to-Noise Ratio: 56 db per channel.
Inputs: Hi-Z microphone and Hi-Z unbalanced bridge; Lo-Z microphone and Hi-Z balanced bridge. With input transformer.
Input Sensitivity: -90 dbm to -30 dbm.
Outputs: Cathode follower, 2.0 volts; 150/600-ohm balanced, +4 dbm. With output transformer.
Heads: Selectable Erase, 2-channel Record and 2-channel Play.
Weight: 50 pounds (60 pounds encased).
Dimensions: 17⅝" wide, 12⅞" high, 12" deep. (17⅝" wide, 14⅛" high, 12" deep encased.)
 50 cps model at extra cost.

MAGNECORD 1022 RECORDER-REPRODUCER

FEATURES: Solid state electronics with regulated power supply and built-in input and output transformers.

SPECIFICATIONS

Tape Speeds: 7.5 and 15 inches per second.
Flutter and Wow: 0.17% at 7.5 ips; 0.15% at 15 ips.
Timing Accuracy: ±0.2%.
Reel Size: 5-, 7- and 8-inch E.I.A. hubs.
Rewind Time: 1200 feet in 80 seconds.
Frequency Response: ±2 db — 25 to 18,000 cps at 7.5 ips; 35 to 22,000 cps at 15 ips.
Signal-to-Noise Ratio: 53 db, both speeds.
Inputs Per Channel: Lo-Z microphone, balanced bridge, unbalanced bridge, auxiliary bridge.
Outputs Per Channel: 150/600-ohm balanced, auxiliary A and auxiliary B unbalanced (+8 dbm).
Heads: Selectable 2-channel Erase, 2-channel Record, 2-channel Play and 1/4-track Play.
Weight: 47 pounds.
Dimensions: 19" wide, 15 3/4" high, 12" deep.
 50 cps model at no extra cost.

MAGNECORD 1021 RECORDER-REPRODUCER



FEATURES: Fully transistorized with regulated power supply. Switchable equalization (N.A.B. standard).

SPECIFICATIONS

Tape Speeds: 3.75 and 7.5 inches per second.
Flutter and Wow: 0.25% at 3.75 ips; 0.2% at 7.5 ips.
Timing Accuracy: ±0.2%.
Reel Size: 5-, 7- and 8-inch E.I.A. hubs.
Rewind Time: 1200 feet in 80 seconds.
Frequency Response: ±2 db — 30 to 8,000 cps at 3.75 ips. 20 to 15,000 cps at 7.5 ips.
Signal-to-Noise Ratio: 53 db, both speeds.
Inputs: Lo-Z microphone, balanced bridge, unbalanced bridge, mixing bridge and auxiliary bridge.
Outputs: 150/600-ohm balanced; unbalanced, auxiliary A and auxiliary B (+8 dbm).
Heads: Full-track Erase, Record and half-track Play.
Weight: 47 pounds (uncased).
Dimensions: 19" wide, 15 3/4" high, 12" deep.
 50 cps model at no extra cost.

MAGNECORD PT6-6A/J

The PT6-6A Recorder and PT6-6J Amplifier are designed for either rack mounting or portable use. Powered by two-speed hysteresis synchronous motor for 7 1/2 and 15 ips, selectable by switch. Low impedance and high impedance inputs are provided as well as 4, 8, 16 and 500 ohm outputs. The unit includes full-track erase and record/playback heads (half-track heads may be specified at no additional cost).

Power Input: 60 cps. 50 cps at extra cost.
Frequency Response: ±2 db 50-15,000 cps at 15 ips; ±2 db 50-7,500 cps at 7 1/2 ips.
Signal-to-Noise Ratio: 50 db.
Distortion: Less than 2% at 10 watts output.
Flutter: 0.3% at 15 ips; 0.5% at 7 1/2 ips.
Size: Amplifier — 19" W, 7" H, 8" D (48.26 cm W, 17.78 cm H, 20.32 cm D). Recorder — 19" W, 7" H, 11" D (48.26 cm W, 17.78 cm H, 27.94 cm D).
Weight: Amplifier — 21 lbs. (9.53 kg) in case. Recorder — 26 lbs (11.79 kg) in case.

- Part No. 097 3806 00 (Type PT6-6A)
With case.
- Part No. 097 4491 00 (Type PT6-6AX)
Without case.
- Part No. 097 3807 00 (Type PT6-6J)
With case.
- Part No. 097 4492 00 (Type PT6-6JX)
Without case.

CROWN 800 TAPE RECORDERS



Available in either monaural or stereo models, the Crown 800 series recorder has many advanced features to make it a professional unit for broadcast stations. Each unit is guaranteed to give top quality performance and is thoroughly tested to assure complete satisfaction.

Among its features: 3 heads for 15, 7 1/2 and 3 3/4 ips operation, AM adjustment control, transistorized photo electric automatic stop for all functions, photo electric program cueing, all-electric relay and solenoid operation, 3-speed electronic reverberation for echo, automatic shift from front panel for 3 3/4 and 7 1/2 ips, automatic torque compensator, accepts 10 1/2" reels, lowest record-playback

intermodulation distortion in industry and over-size life-time bearings. The stereo version (Type 822) is similar to the monaural unit shown except for the addition of an identical amplifier unit for the second channel.

Power Input: 60 cps, 50 cps at extra cost.

Size: Monaural — 19" W, 15" H, 10½" D (48.26 cm W, 38.1 cm H, 26.67 cm D). Stereo — 19" W, 18½" H, 10½" D (48.26 cm W, 46.99 cm H, 26.67 cm D).

Weight: Monaural — 48 lbs. (21.77 kg). Stereo — 56 lbs. (25.40 kg).

Speed	Frequency Response	Flutter and Wow	Noise Ratio
15	±2 db, 30-30,000 cps	.06%	57 db
7½	±2 db, 30-20,000 cps	.09%	55 db
3¾	±3 db, 30-13,000 cps	.18%	51 db

Part No. 099 0479 00 (Type BX801)

Less case.

Part No. 099 0731 00 (Type BX822)

Less case.

Part No. 099 0481 00

Case for Type 8801 monaural recorder.

Part No. 099 0482 00

Case for Type 824 stereo recorder.

CROWN RC8 REMOTE CONTROL

This unit, with indicator light, is a duplicate of the rewind, play, forward and stop functions mounted on the recorder cabinet. The RC8 includes 25' cable.

Part No. 099 0158 00 — Remote control unit.

CONCERTONE TAPE RECORDERS



Designed for rugged reliability under continuous performance conditions, the Series 90 meets exacting broadcast requirements. The Concertone Edit-O-Matic® feature

enables quick cueing, and a flutter filtering system virtually eliminates spurious vibrations and tape flutter.

The unit accommodates up to four heads for stereo. A multichannel erase head provides separate erase for each track to assure easy monophonic and sound-on-sound recording. Separate gain controls for each input signal permit recording from two different sources simultaneously, mixing sounds for proper balance. Handles all reel sizes from 5" to 10½". Available in monophonic full-or half-track and stereo 2- or 4-track versions in studio consoles, portable case or rack mounting.

Tape Speeds: 15 and 7½ ips; or 7½ and 3¾ ips.

Frequency Response: ±2 db, 40-15,000 cps at 15 ips; ±2 db, 40-12,000 cps at 7½ ips; ±2 db, 50-7,500 cps at 3¾ ips.

Signal-to-Noise Ratio: Full track — 55 db at 7½ and 15 ips; 50 db at 3¾ ips. Stereo — 50 db at 7½ and 15 ips; 45 at 3¾ ips (based on 2% distortion).

Timing Accuracy: 99.8% or better.

Flutter and Wow: Less than 0.1% rms at 7½ and 15 ips; less than 0.3% rms at 3¾ ips.

Rewind and Fast Forward: 90 seconds for 2,400 ft.

Input Impedance: High impedance unbalanced; 50, 250, 600 ohms balanced or unbalanced with plug-in transformers.

Output Impedance: 600 ohms balanced with terminating switch to allow connections to high impedance input.

Output Level: 0 VU.

Power Requirements: Monophonic — Approx. 280 watts, 115 v, 60 cps (50 cps on special order). Stereo — Approx. 320 watts, 115 v, 60 cps.

Size: Transport — 19" W, 15¾" H, 8" D (48.26 cm W, 15¾ cm H, 20.32 cm D). Amplifier — 19" W, 5¼" H, 8¼" D (48.26 cm W, 13.34 cm H, 20.96 cm D).

Weight: Transport — 48 lbs (21.77 kg). Amplifier — 12 lbs. (5.44 kg).

Part No. 099 0373 00 (Type 91)
Full track, 15 and 7½ ips, rack mounted.

Part No. 099 0374 00 (Type 92)
Half track, 15 and 7½ ips, rack mounted.

Part No. 099 0375 00 (Type 93)
Two track stereo, rack mounted.

Part No. 099 0376 00 (Type 93-4)
Four track stereo, rack mounted.

No Part Number
Factory installed conversion kit to 3¾ and 7½ ips. Specify "A" following model number.

No Part Number
Factory installed conversion kit for 50 cps operation. Specify "50 cps" following model number.

Part No. 099 0377 00
Extra playback head, two track or four track stereo head, factory installed.

Part No. 099 0378 00
Complete stereo head assembly. Four heads (erase, record, play, play) two or four track stereo. Factory installed.

Part No. 099 0379 00 (Type 700105)
Transformer, 50-ohm microphone, input.

Part No. 099 0380 00 (Type 700106)
Transformer, 250-ohm microphone, input.

Part No. 099 0381 00 (Type 700107)
Transformer, 10,000-ohm line-level, input.

Part No. 099 0382 00 (Type 700108)
Transformer, 600-ohm line-level, input).

Part No. 099 0383 00 (Type 700122)
Portable case (for transport or two preamplifiers).

Part No. 099 0384 00 (Type 700133)
Portable case (for one preamplifier).

Part No. 099 0385 00 (Type 700120)
Remote control with 25 ft. cord.

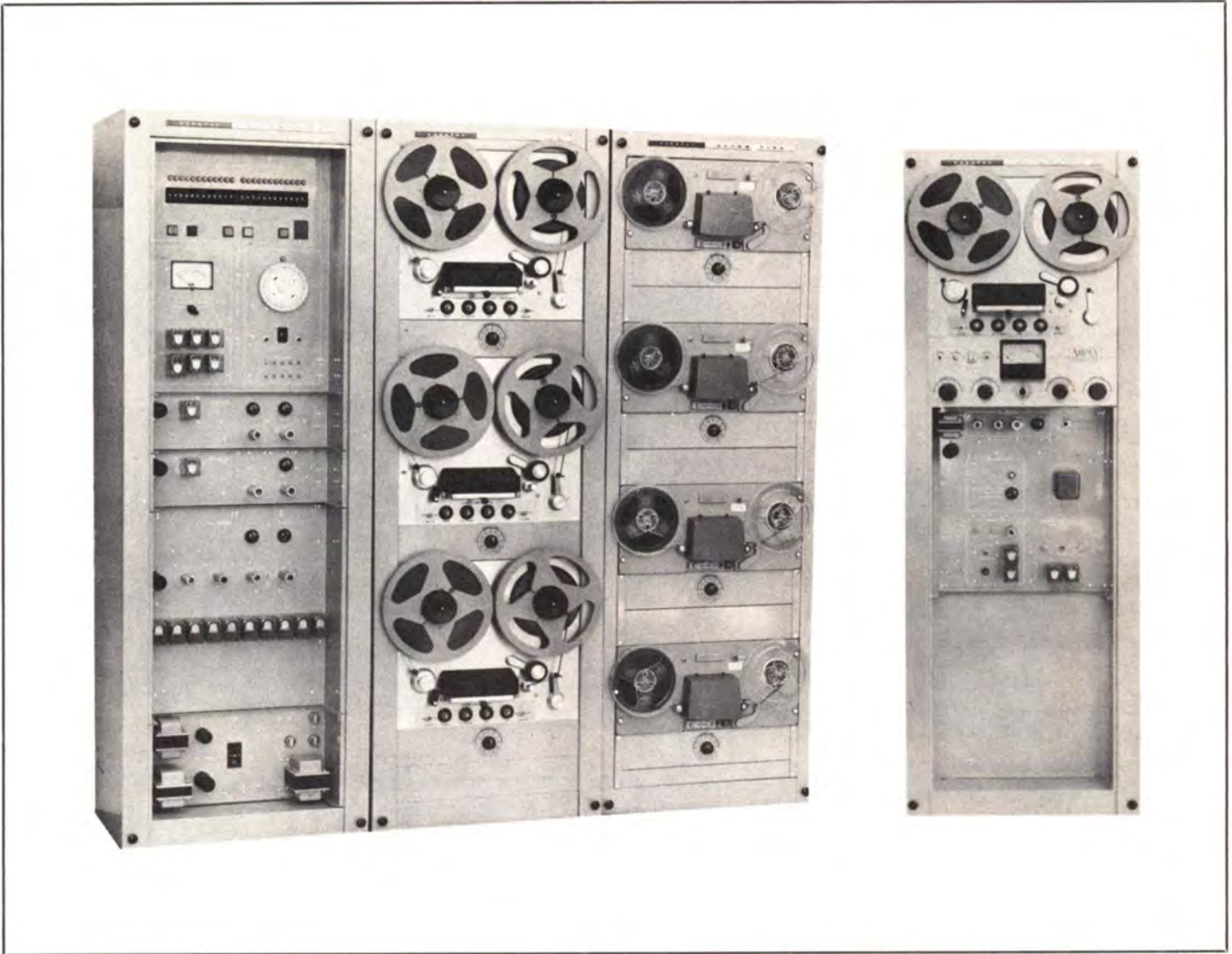

SCHAFFER MODEL 800 AUTOMATION

Schafer Model 800 Automation is a completely new broadcast automation system designed for the station that wants to prepare a full day of programming in just a few hours and still maintain the flexibility necessary for today's requirements. Smooth, tight programming becomes extremely simple. Up to ten or more program sources may be controlled by the control unit, allowing a multitude of program combinations. Program categories are assembled automatically at the desired pace with a reliability factor difficult, if not impossible, to achieve with a manual operation. A 25-cycle tone allows over-lap, extremely tight segue, or any timing desired. Automatic tape cueing is accomplished in a number of different ways, including the latest photocell method.

The format may be interrupted or changed at any time, even when the automation is playing on the air. If a channel should fail, the auto-step circuit sustains on-the-air operation and that channel is by-passed until it is repaired.

The remote control for the Program Preparation Unit provides all controls necessary for recording tapes for use on automation. Automation remote control is also provided.

A built-in clock can be used to control the program format, or be used to make insertions at predetermined times.

New digital switches and new miniature indicator lights give a new uncluttered appearance to the Automation system. The lighted digital readout indicates which channel is playing. The built-in control panel multimeter can be used to check all power supply voltages, as well as audio output. The Control Unit contains a new solid state power supply and new Automatic Electric dual contact plug-in relays. A monitor is built in for cueing purposes.

The system is available with any configuration of recorders or other accessories and can incorporate recorders or accessories now owned by the station.

Also available for 50 cps power input at no extra cost.

SCHAFFER MODEL SA-100 SPOT LOCATOR



The SA-100 Spot Locator was developed to fill a need for high fidelity record-playback facilities to be used in the AM and FM broadcasting industry. This is a device that eliminates storage problems associated with acetate discs, tape cartridges, rolls of tape, etc. Recording and playback is accomplished with the absolute minimum of effort and time.

Connect the SA-100 Spot Locator to an Ampex Recorder and select any one of the 100 spots stored on the tape by merely setting the switches.

SA-100 REMOTE CONTROL

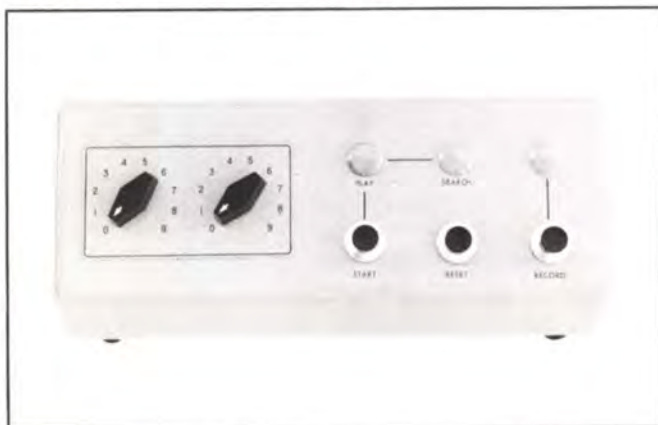

Remote Control Box permits operation of the Spot Locator from any remote location.

Memory allows pre-setting of sequence of spots for hours in advance for automatic or full automation operation.

SCHAFFER MODEL TM-8 AUDIO CLOCK



When time signals are desired in program format it can be easily accomplished with singing jingles or verbal announcements on the Audio Clock. Each tape deck holds 320 time signals. The control unit advances each deck every minute to keep the time signals synchronized with the clock whether each time signal is aired or not. The TM-8 is usually furnished with 2 Ampex PB-PR-10's.

SCHAFFER MODEL APL-1 AUTOMATIC PROGRAM LOGGER

Meeting FCC requirements the Schaffer Automatic Program Logger eliminates the necessity to keep a written program log. It records 24 hours on a 7-inch reel of 1200 feet of ordinary 1/4 inch tape. The Monitor Alarm provides a monitor, as well as an alarm, should the program or the logger fail.

The APL-2 (not pictured), provides a second logger recorder to permit playback or recording a second source while the first recorder is in operation. The recorders operate at 1/3 ips, as well as 3 3/4-7 1/2 ips. Low cost "white box" tape is available and is adequate for this logging purpose.

SCHAFFER MODEL ANP-1 AUTOMATIC NETWORK PROGRAMMER

Operates in conjunction with the Model 800 Automation System to automatically coordinate an automation system and a network.

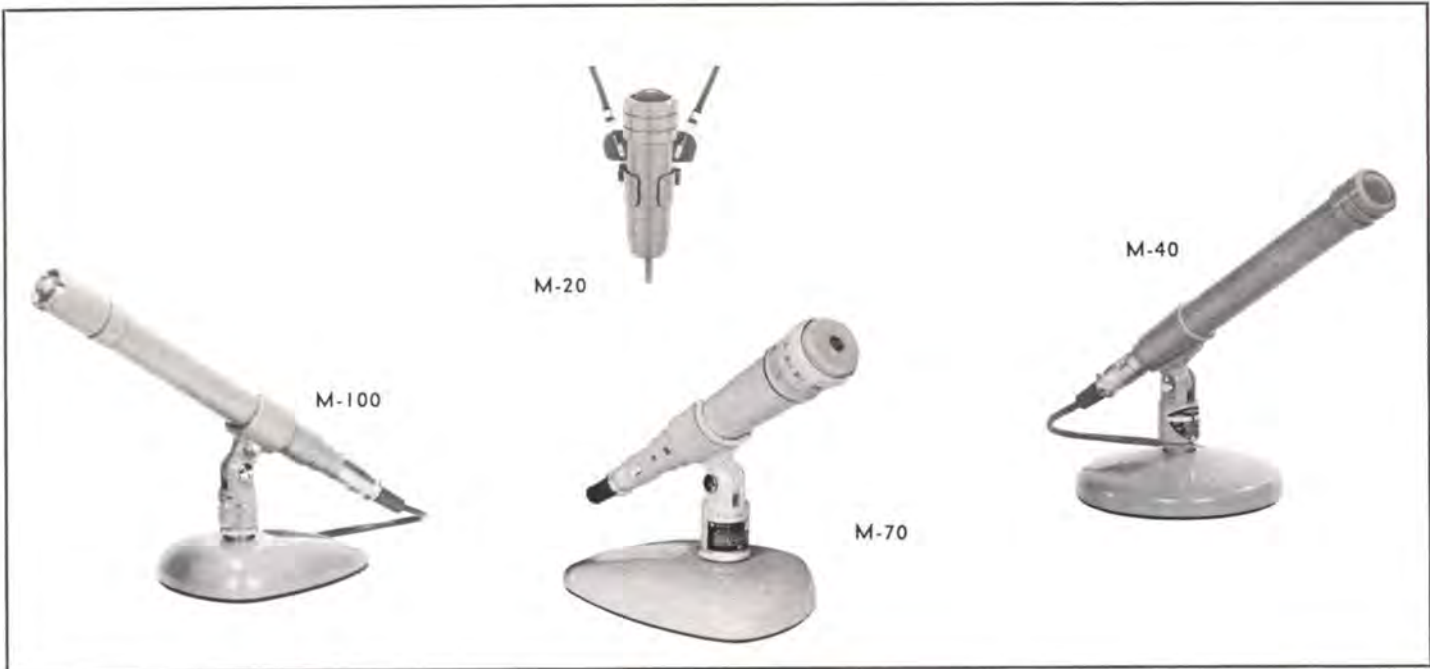

COLLINS M-100 MICROPHONE

Gives a flexibility unequaled by any other microphone in its price range. Its response is smooth and uniform from 40 to 20,000 cps, but it may be adjusted for varying audio conditions when used by the soprano or the low-voiced sportscaster, or on exceptionally difficult remote broadcasts. Simple screwdriver adjustments allow a low frequency cutoff at 40, 80 or 160 cps, and a high frequency cutoff at 10,000 or 20,000 cps.

The Collins M-100 is a dynamic, omnidirectional microphone that may be used with any amplifiers having a 35-80 ohm or 150-250 ohm input. Includes 20 ft. of cable and desk stand with grip cam-lock to allow easy removal from the stand without disconnecting.

Impedance: 50 ohms or 200 ohms, selectable.

Frequency Response: 40-20,000 cps.

Output Level: -62 db, with reference to 1 mw/10 dynes/cm².

Size: 10½" long, 1" diameter (26.67 cm L, 2.54 cm diameter).

Weight: 9½ oz. (0.269 kg).

Color: Non-reflecting blue-gray.

Part No. 099 0078 00

COLLINS M-20 MICROPHONE

This small and rugged lavalier microphone frees hands in one-man speaking situation such as weather shows and demonstrations. It is small enough to be hidden behind a necktie or lapel. Supplied with lavalier clip and 25 ft. of 3-conductor cable. Essentially omnidirectional polar pattern. Desk stand available on order.

Impedance: 50 ohms or 200 ohms, selectable.

Frequency Response: 60-18,000 cps.

Output Level: -57 db, with reference to 1 mw/ 10 dynes/cm².

Size: 4" long, 1" diameter (10.16 cm L, 2.54 cm diameter).

Weight: 3½ oz. (0.099 kg).

Color: Non-reflecting blue-gray.

Part No. 097 5464 00

M-20.

Part No. 097 6627 00

Replacement lavalier clip for M-20.

Part No. 097 5826 00

Desk stand for M-20.

Part No. 099 0870 00

Replacement cord and clip.

COLLINS M-40 MICROPHONE

Ideal for panel discussions, dinner meetings and interviews. Equipped with desk stand and 20 ft. of three-conductor, plastic jacketed cable. Essentially omnidirectional polar pattern.

Impedance: 50 ohms or 200 ohms, selectable.

Frequency Response: 40-20,000 cps.

Output Level: -59 db, with reference to 1 mw/ 10 dynes/cm².

Size: 9⅝" long, 1" diameter (24.45 cm long, 2.54 cm diameter).

Weight: 11 oz. (0.31 kg).

Color: Non-reflecting blue-gray.

Part No. 097 5463 00

COLLINS M-70 MICROPHONE

Provides highly directional sound selectivity to double the conventional working distance and to cut out unwanted background sounds. It is especially useful in small booths where reflecting surfaces could be a problem. Comes equipped with desk stand and a 20-foot, three-conductor shielded cable.

Impedance: 50 ohms or 200 ohms selectable.

Frequency Response: 40-15,000 cps.

Output Level: -55 db below 1 mn/10 dynes/cm².

Size: 6⅜" long, 1 17/32" diameter (17.30 cm long, 3.89 cm diameter).

Weight: 12 ounces, (0.34 kg) (without cable).

Color: Non-reflecting blue-gray.

Part No. 099 2402 000

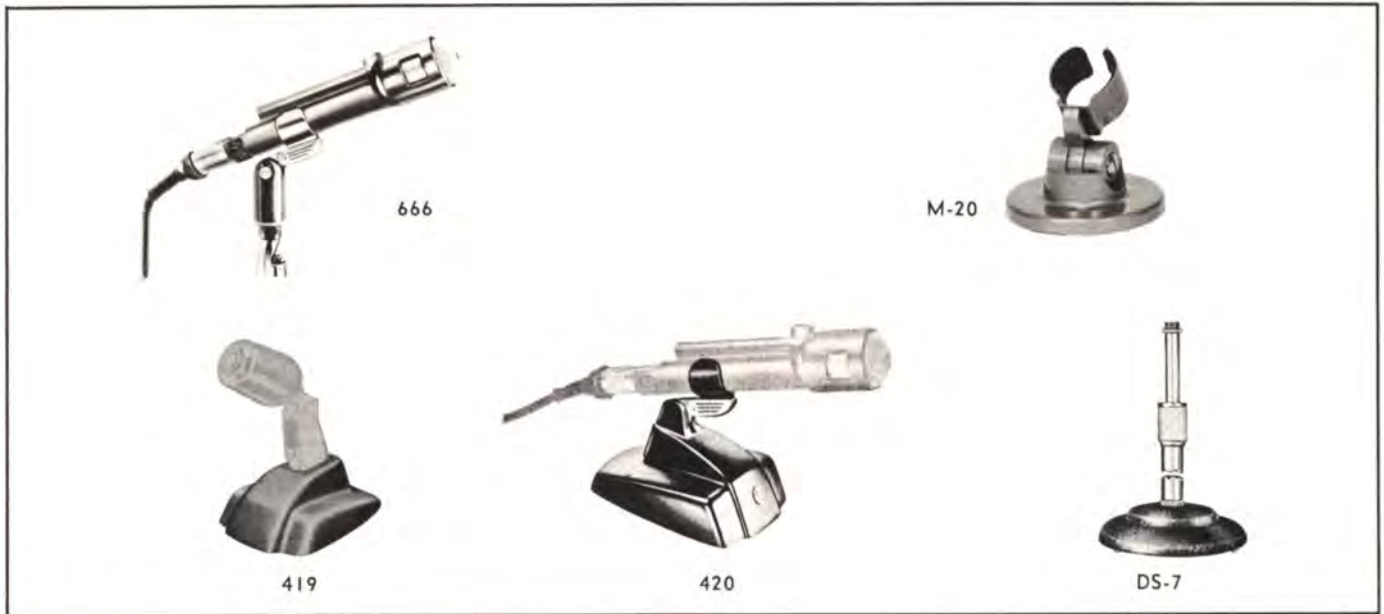

ELECTRO-VOICE 666 CARDIOID MICROPHONE

This microphone provides high discrimination against sounds from back hemisphere. Permits close talking with no bass accentuation and increases working distance over pressure microphones by factor of 1.7:1 due to polar pattern. Clamp-on stand mount with $\frac{5}{8}$ "-27 thread, $\frac{1}{2}$ " pipe thread adapter and 20' cable included.

Impedance: Changeable on internal terminal board.

Wired for 150 ohms, taps at 50 and 250 ohms.

Frequency Response: 30-16,000 cps.

Output Level: -55 db.

Size: $7\frac{1}{2}$ " (19.05 cm) long, $1\frac{3}{4}$ " (4.45 cm) diameter.

Weight: 11 oz. (0.31 kg).

Color: Gray.

Part No. 097 3036 00

ELECTRO-VOICE 665 CARDIOID MICROPHONE

Similar in design and function to the Electro-Voice 666, but for less exacting applications. Includes 18' cable.

Impedance: 50 ohms or 200 ohms, selectable by recessed switch.

Frequency Response: 50-14,000 cps.

Output Level: -55 db.

Size: $7\frac{3}{8}$ " (18.26 cm) long, $1\frac{7}{8}$ " (4.76 cm) diameter.

Color: Gray.

Part No. 097 2211 00

ELECTRO-VOICE AND ALTEC-LANSING MICROPHONES

A complete line of Electro-Voice and Altec-Lansing general purpose and specialized microphones, stands, call letter plates and accessories is sold by your Collins Broadcast Equipment Sales Engineer.

COLLINS M-20 MICROPHONE DESK STAND

A small, non-reflecting blue-gray stand that holds the Collins M-20 Microphone. The M-20 is held with a felt padded clamp that allows the microphone to be slipped in and out of the stand easily.

Part No. 097 5826 00

ELECTRO-VOICE 419 MICROPHONE DESK STANDS

Model 419 is used with microphones using large-type stud such as EV Model 665. Model 418 desk stand is similar but for use with microphone using small-type stud. Both have die cast base and gray finish.

Part No. 097 3835 00

(Type 419)

Part No. 097 3132 00

(Type 418)

ELECTRO-VOICE 420 MICROPHONE DESK STAND

For use with microphones one inch in diameter. Clamp attachment mounts one inch cylindrical microphones without tools. Heavy cast iron, gray finish.

Weight: 3 lbs. (1.36 kg).

Part No. 097 2438 00

ATLAS DS-7 MICROPHONE DESK STAND

A general purpose, chrome plated adjustable desk stand with base of cast iron and finished in gun metal shrivel finish. Stable base is equipped with pads to prevent damage to desk. Equipped with standard "velvet action" clutch adjustment. Thread size at microphone end is $\frac{5}{8}$ "-27. Adjustable from 8" to 12" (20.32 cm to 30.48 cm).

Weight: 3 lbs. (1.36 kg).

Part No. 097 1119 00

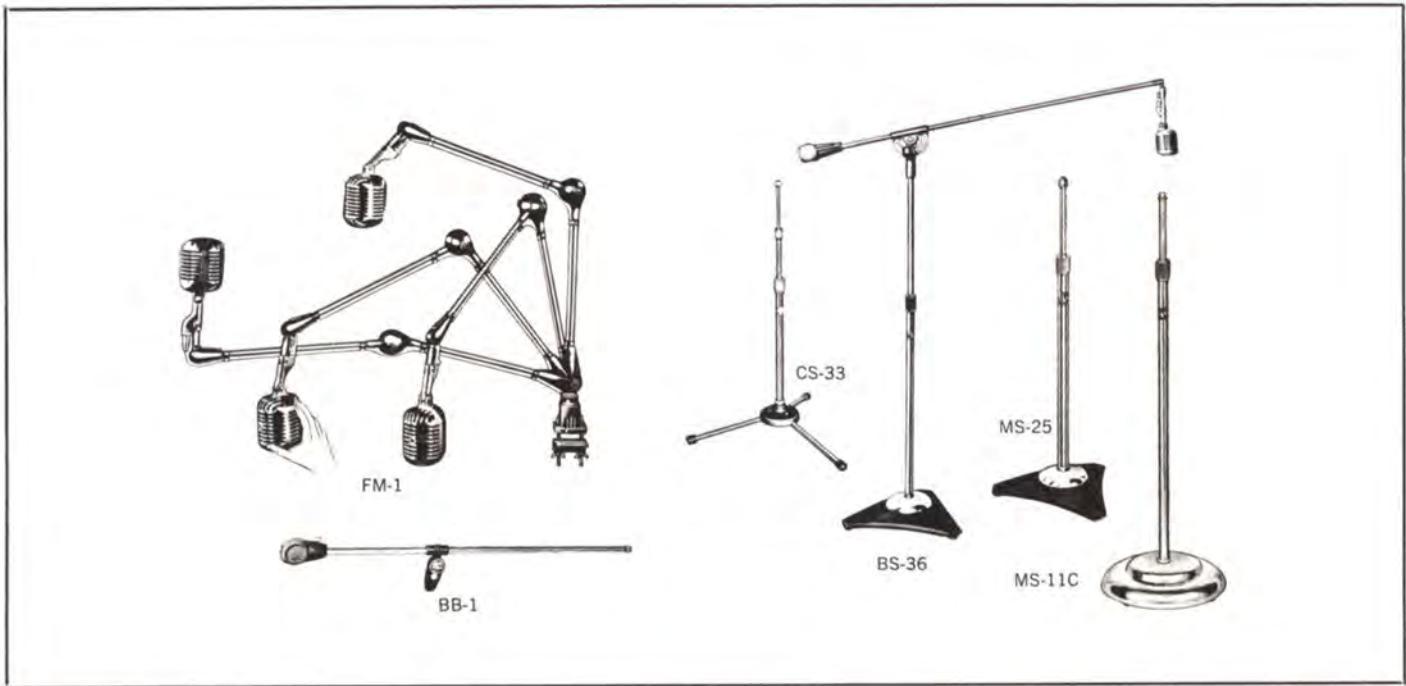

FLEXO MIKESTER FM-1

This arm will handle any mike up to 4 lbs. It can be instantly positioned, incorporates a patented enclosed spring-controlled swiveling device, swings out 36" in any direction when fully extended. Clamps or screws to any position. Clips hold cable in place.

Weight: 4¾ lbs. (2.15 kg).

Part No. 097 1499 00

ATLAS CS-33 MICROPHONE FLOOR STAND

Fully collapsible unit with "come apart" base design. The stand has a spring lock leg-holding mechanism so it may be easily disassembled for carrying. No tools or screw fastenings are required to hold the base assembly together. Chrome plated legs tipped with skid-proof rubber shock absorbent bumpers eliminate vibrational conductivity. Model CS-33 adjusts from 26" to 64" (66.04 cm to 162.56 cm) and weighs 4 lbs. (1.81 kg).

Part No. 097 1267 00

ATLAS BS-36 MICROPHONE BOOM STAND

Features "safety air-lock cushion" built into the vertical section to prevent slippage of the upright. Deluxe model BS-36W with ball bearing swivel castors available.

Boom Length: 62" (157.48 cm).

Vertical Length: 48" to 72" (121.92 cm to 182.88 cm).

Base Diameter: 17" (43.18 cm).

Weight: 33 lbs. (14.97 kg).

Finish: Chrome and gun metal.

Part No. 097 1500 00 (Type BS-36)
Part No. 097 1790 00 (Type BS-36W)

ATLAS BB-1 MICROPHONE BOOM

This 31" microphone boom may be attached to any type of floor stand. All swivel parts are precision die castings resulting in smooth operation and secure positioning. Boom is chrome plated and has ⅝"-27 thread.

Weight: 3½ lbs. (1.59 kg).

Part No. 097 0984 00

ATLAS MS-25 FLOOR STAND

Features "safety air-lock cushion" to prevent slippage of telescoping section. Uses a large diameter, oversize telescoping tube (⅞" telescoping tube, 1⅛" base tube). Terminated in ⅝"-27 thread.

Finish: Chrome and gray wrinkle.

Height Adjust: 37" to 66" (93.98 cm to 167.18 cm).

Base Diameter: 17" (43.18 cm).

Weight: 24 lbs (10.89 kg).

Part No. 097 1510 00

ATLAS MS-11C FLOOR STAND

Features an extended length clutch body, inner lined with a wear-proof locking collet which grips without jamming, slipping or sudden dropping. Includes self-leveling, shock absorbing base pads, plus three additional "anti-tip" points located between the base pads. Terminates in a ⅝"-27 thread.

Finish: Chrome or gray wrinkle (Model MS-10C).

Height Adjust: 35" to 65" (88.90 cm to 165.10 cm).

Base Diameter: 10" (25.4 cm).

Weight: 12 lbs. (5.44 kg).

Part No. 097 1511 00 (Type MS-11C)
Part No. 097 5729 00 (Type MS-10C)

COLLINS CUSTOM CONTROL DESKS

Attractiveness is combined with operational efficiency and economy in Collins control desks, custom designed to each broadcaster's requirements. These desks are sturdily constructed of wood covered with any of a wide range of patterns of long lasting Formica.

Among the features that may be incorporated without sacrificing attractiveness are adjustable feet, built-in

record compartments, hidden console cables and provisions for rack mounting.

A Collins tape cartridge system desk wing console may be placed on left wing to give complete studio facilities in one compact unit. Collins will provide free estimates upon submission of the physical layout of the studio and an outline of functions desired for inclusion in the desk.

No Part Number



COLLINS CS-12 LOUSPEAKERS



Producing the very finest in high fidelity sound, the Collins CS-12 loudspeaker produces a consistently stable and precise definition. The speaker is designed to operate equally well at full range or as woofers in multiway systems. The CS-12 features Radax construction, which divides the sound between the two cones. A mechanical crossover, when the smaller cone responds to the higher frequencies, occurs at 1,800 cps.

A slug-type magnet is used for concentrating flux density into the air gap. This type magnet has the lowest possible leakage and greatest structural strength. The high frequency long throw voice coil remains in the air

gap even on the longest of excursions to prevent non-linear operation.

An edge-wound voice coil, which gains an equivalent of five extra watts from most amplifiers over round-wire coils, is wound with precision, flattened ribbon conductor.

Each speaker is carefully tested and inspected before leaving the factory. An individual frequency response curve check is run on each speaker so that it matches the performance of the laboratory standard.

Frequency Response: 30-13,000 cps.

EIA Sensitivity Rating: 43 db.

Free-Space Cone Resonance: 40 cps.

Power Handling Capacity:

Program Material: 20 watt.

Peak: 40 watt.

Critical Damping Factor: 15.

Impedance: 8 ohm.

Mechanical Crossover: 1800 cps.

Voice Coil Diameter: 2".

Total Flux: 70,700 maxwells.

Power Required for 100 db level: 12 watt.

Mounting: Four 1/4" holes equally spaced on 1 1/2" circle.

Baffle Opening: 11".

Size: 12 1/4" diameter, 3 1/2" deep (31.12 cm diameter, 8.89 cm deep).

Weight: 5 1/2" lbs. (2.49 kg).

Part No. 097 6039 00

(Type CS-12)

Part No. 099 2686 00 Stancor A-3818 Speaker Transformer

JENSEN P12-T SPEAKER

This economy speaker is ideal for a high fidelity system to which additional units may be added.

Impedance: 3.2 ohms.

Power Rating: 12 watts.

Baffle Opening: 10½". Jensen transformer (Stancor A-3818 speaker transformer) for P12-T speaker matches to 600 ohms.

Part No. 097 2119 00 (Type P12-T)
Part No. 099 2686 00
Stancor A-3818 speaker transformer.

JENSEN P8-T3 SPEAKER

Similar to the P12-T.

Impedance: 3.2 ohms.

Power Rating: 7 watts.

Baffle Opening: 6¾". Jensen transformer (Stancor A-3818 speaker transformer) for P8-TS speaker matches to 600 ohms.

Part No. 099 2644 00 P8-T3
Part No. 099 2686 00 Stancor A-3818 speaker transformer.

JENSEN LEVEL CONTROLS

Designed for use in voice coil or line circuits of similar nominal impedance, Jensen level controls are of the two-section L-pad type. They provide continuously adjustable level without disturbance of other circuit levels or total impedance. Single hole panel mounting. Complete with lock nut, pointer knob and flat metal escutcheon plate. Model ST-760 for 4 ohms impedance, 15 watts. Model ST-411 for 8 ohms impedance, 35 watts.

Part No. 097 2190 00 (Type ST-760)
Part No. 097 2207 00 (Type ST-411)

STANCOR A-3818 TRANSFORMER

Transformer for Collins CS-12, Jensen P12-T and P8-TS speakers.

Primary Impedance: 500/1000/1500 ohms.

Secondary Impedance: 15/8/4 ohms.

Power Rating: 25 watts.

Part No. 099 2686 00

KAAR CONALERT



Designed expressly for CONELRAD Radio Alert. Built for 24-hour service, it gives automatic alarm with visual and aural warning. At time of radio alert, the speaker is automatically connected, you hear CONELRAD message and red pilot lamp on panel is lighted. Provision is also made for external alarm. Available in either cabinet or rack mounting models.

Part No. 097 5423 00
Rack mounted.

ARGOS BAFFLES

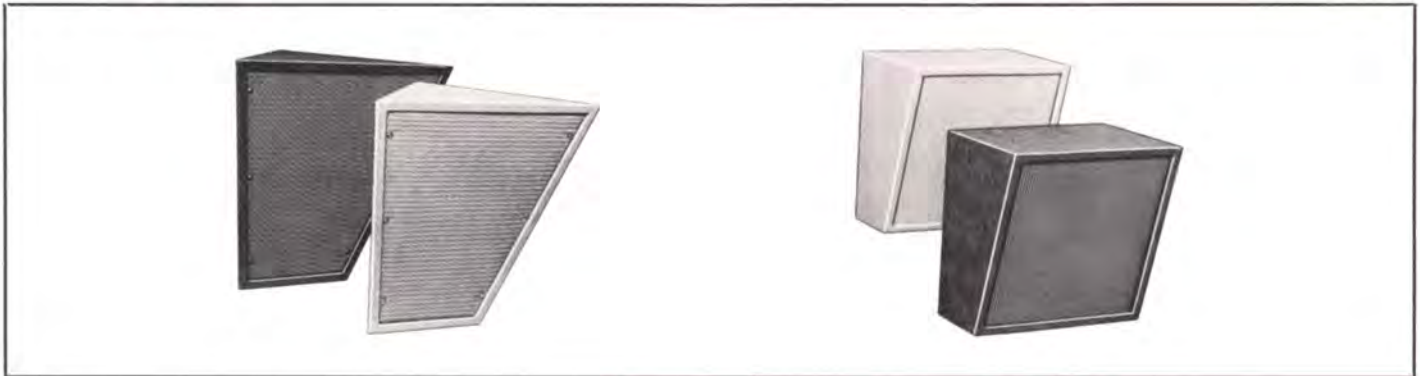

Entire front is inset with plastic grille and cloth covered panel. Constructed of plywood and hardboard for good resonant tone. Extra reinforcing blocks and four bolts installed for mounting speakers. Covering is plastic coated leatherette. Available in blonde or walnut. Slanting corner baffle for 8" speaker (SCB-8D) or 12" speaker (SCB-12D).

Weight: 6 lbs. or 8 lbs. (2.72 kg or 3.63 kg). Wall baffle for 8" speaker (WB-8C) or 12" speaker (WB-12C).

Weight: 2½ lbs. or 4¼ lbs. (1.13 kg or 1.93 kg).

- | | |
|--|----------------|
| Part No. 099 2374 00
Walnut finish. | (Type SCB-8D) |
| Part No. 099 2375 00
Blonde finish. | (Type SCB-8D) |
| Part No. 099 2376 00
Walnut finish. | (Type SCB-12D) |
| Part No. 099 2377 00
Blonde finish. | (Type SCB-12D) |
| Part No. 097 6006 00
Walnut finish. | (Type WB-8C) |
| Part No. 097 6008 00
Blonde finish. | (Type WB-8C) |
| Part No. 097 6007 00
Walnut finish. | (Type WB-12C) |
| Part No. 097 6009 00
Blonde finish. | (Type WB-12C) |

MIRITEL AIR ALERT



Designed to control visible and/or audible alarm circuits on CONELRAD signal from local or sky wave stations. Frequency tunable from 550 to 1600 kc. Built-in speaker operates upon alarm. Relay circuit is voltage regulated. External bell or light control terminals and antenna terminals on rear terminal board. Available for rack or table mounting.

Part No. 097 3192 00
Rack mounted.

TRIMM HEADPHONES

Lightweight, rugged headphones with black Bakelite shell and cap. Rubber covered headband.

Impedance: 600 ohms (Model 156) or 17,000 ohms (Model 157).

Weight: 5 oz. (0.14 kg).

Part No. 273 0003 00 (Type 156)
Part No. 273 0004 00 (Type 157)

BRUSH BA-206 HEADPHONES



The Brush BA-206 headphones have an exceptionally flat response out to 10,000 cps and create outstanding fidelity of reception. Their high impedance and negligible power requirements allow monitoring without any effects on associated equipment. The special "Metalseal" crystal elements provide maximum protection against excessive humidity.

Part No. 099 0495 00

BRUSH BA-200 HEADPHONES



Ideal for general purpose service, the Brush BA-200 headphones have a frequency range from 100 to 5,000 cps. They are especially suitable for general laboratory and studio work as well as for the skilled amateur.

Impedance: 45,000 ohms at 1,000 cps.

Weight: 6 oz. (0.17 kg).

Part No. 273 0002 00

PATCH CORDS

The plugs are of the shielded type, with the sleeves tied together and grounded. The circuit is maintained through connections to the plug tips. The following lengths are available: 6"; 12"; 24"; 36"; 48"; 60"; and 120". Other patch plugs, phone jacks and single circuit jacks available.

Part No. 361 0010 00 (6")
Part No. 361 0011 00 (12")
Part No. 361 0012 00 (24")
Part No. 361 0013 00 (36")
Part No. 361 0014 00 (48")
Part No. 361 0015 00 (60")
Part No. 361 0016 00 (120")

TRIMM JACK PANELS

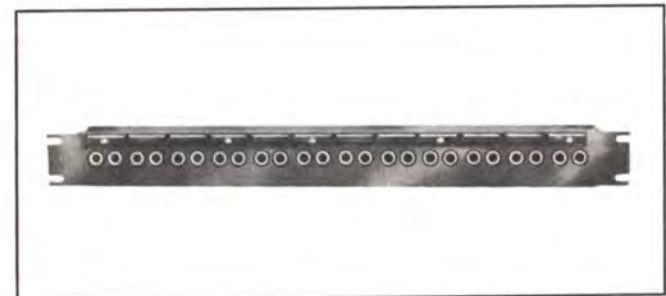

These panels are available in 12 pair, single row and 24 pair, double row models to fit any standard 19" rack and include such features as: solid $\frac{5}{8}$ " thick Bakelite panel with steel reinforcing; heavy gauge, special spring temper nickel/silver alloy leaves; ground lugs aligned to allow single ground bus to be run full length of strip; large palladium silver contacts; connection lugs fanned out for ease of soldering.

Part No. 097 3561 00
12-pair, single row.
Part No. 097 4200 00
24-pair, double row.

TELECHRON 1H1612 STUDIO CLOCK



The Telechron "Commerce" clock has a 12" dial, rich brown case.

Part No. 097 1735 00

SHIELDED WIRE AND MICROPHONE CABLE

8758 — Belden 2-conductor #20, twisted, shielded pair, stranded copper conductors, vinyl insulated.

8738 — Belden 2-conductor #22, twisted, shielded pair, solid copper conductors, vinyl insulated.

439-5900-00 — Two-conductor #22 stranded, 7 No. 30 conductors, one red and one black conductor with one #22 groundwire. Shield is single right-hand wrap, #30 AWG maximum diameter of stranding. Nylon jacket, maximum outside diameter is .140".

8422 — Belden, shielded microphone cable, 2-conductor #22.

8412 — Belden, shielded microphone cable, 2-conductor #20.

423-0219-00 — High voltage wire, 15 kv breakdown insulation.

425-0061-00 — Shielded pair, #16 stranded cotton insulated, 15 amps.

425-0151-00 — Shielded pair, #12 stranded cotton insulated, 20 amps.

- Part No. 097 6030 00 (Type 8758)
- Part No. 097 6029 00 (Type 8738)
- Part No. 439 5900 00 (Type 439 5900 00)
- Part No. 097 1142 00 (Type 8422)
In lengths of less than 100 ft. More than 100 ft., see below.
- Part No. 097 1142 00 (Type 8422)
In lengths of 100 ft. or more. Less than 100 ft., see above.
- Part No. 425 0250 00 (Type 8412)
In lengths of less than 100 ft. More than 100 ft., see below.
- Part No. 425 0250 00 (Type 8412)
In lengths of 100 ft. or more. Less than 100 ft., see above.
- Part No. 423 0219 00 (Type 423 0219 00)
- Part No. 425 0061 00 (Type 425 0061 00)
- Part No. 425 0151 00 (Type 425 0151 00)

TRIMM 427-6 TERMINAL BOARD

Contains two groups of terminals, each 13 terminals long and 6 terminals high.

Part No. 097 6282 00

BUD CR-1773-B RACK CABINET



A heavy duty rack cabinet that is custom-made for Collins Radio Company. Finished in light gray, this cabinet is made of sturdy steel with a door on the back and provision at the top for mounting a blower fan. Provides 70" of panel space. Shipped knocked down.

Size: 19" W, 76" H, 17 1/8" D (48.26 cm W, 193.04 cm H, 43.5 cm D).

Part No. 099 2474 00

RACK CABINET BLANK PANELS

These blank panels of 3/16" aluminum are finished in light gray to match the BUD CR-1773-A Rack Cabinet. Size: 19" W (48.26 cm W) and in heights as listed below.

	Inches	Cm.
Part No. 502 8389 123	(1 3/4")	(4.45)
Part No. 502 8393 113	(3 1/2")	(8.89)
Part No. 502 8397 123	(5 1/4")	(13.34)
Part No. 502 8401 113	(7")	(17.78)
Part No. 502 8405 113	(8 3/4")	(22.23)
Part No. 502 8409 123	(10 1/2")	(26.67)
Part No. 502 8413 113	(12 1/4")	(31.12)
Part No. 502 8417 113	(14")	(35.56)



CANNON CONNECTORS

Collins Radio Company is an authorized distributor of the full line of Cannon Connectors. The following is a listing of those connectors most often required in audio applications. All are three-contact plugs unless otherwise indicated.

P3-CG-11S — Cannon female cable plug.

P3-CG-12S — Cannon male cable plug.

P3-13 — Cannon female panel receptacle.

P3-14 — Cannon male panel receptacle.

P3-35 — Cannon single gang female wall receptacle.

P3-35-2G — Cannon 2 gang female wall receptacle.

XLR-3-11C — Cannon female cable plug.

XLR 3 11SC — Canon female cable plug with latch-lock cable clamp.

XLR-3-12C — Cannon male cable plug.

XLR-3-12SC — Cannon male cable plug with latch-lock cable clamp.

XLR-3-13 — Cannon female panel receptacle, flush mount.

XLR-3-13N — Cannon female panel receptacle with lock nut.

XLR-3-14 — Cannon male panel receptacle, flush mount.

XLR-3-14N — Cannon male panel receptacle with lock nut.

XLR-3-35 — Cannon single gang female wall receptacle.

XLR-3-35-2G — Cannon 2-gang female wall receptacle.

XLR-3-36 — Cannon single gang male wall receptacle.

XLR-3-36-2G — Cannon 2-gang male wall receptacle.

UA-3-11 — Cannon female cable plug.

UA-3-12 — Cannon male cable plug.

PA-3-13 — Cannon female panel receptacle, flush mount.

UA-3-14 — Cannon male panel receptacle, flush mount.

UA-3-31 — Cannon female wall mount receptacle.

UA-3-32 — Cannon male wall mount receptacle.

Part No. 370 2180 00 (Type P3-CG-11S)

Part No. 370 2190 00 (Type P3-CG-12S)

Part No. 370 2060 00 (Type P3-13)

Part No. 370 2090 00 (Type P3-14)

Part No. 370 2150 00 (Type P3-35)

Part No. 370 2170 00 (Type P3-35-2G)

Part No. 097 5372 00 (Type XLR-3-11C)

Part No. 097 5371 00 (Type XLR-3-11SC)

Part No. 097 5370 00 (Type XLR-3-12C)

Part No. 097 5369 00 (Type XLR-3-12SC)

Part No. 097 5368 00 (Type XLR-3-13)

Part No. 097 5367 00 (Type XLR-3-13N)

Part No. 097 5366 00 (Type XLR-3-14)

Part No. 097 5365 00 (Type XLR-3-14N)

Part No. 097 5364 00 (Type XLR-3-35)

Part No. 097 5363 00 (Type XLR-3-35-2G)

Part No. 097 5362 00 (Type XLR-3-36)

Part No. 097 5361 00 (Type XLR-3-36-2G)

Part No. 370 2082 00 (Type UA-3-11)

Part No. 370 2081 00 (Type UA-3-12)

Part No. 370 2079 00 (Type UA-3-13)

Part No. 370 2083 00 (Type UA-3-14)

Part No. 099 0463 00 (Type UA-3-31)

Part No. 099 0464 00 (Type UA-3-32)



COLLINS 808A-1 REMOTE TURNTABLE-CONSOLE

A compact, completely transistorized portable unit, the three-channel 808A-1 is designed for quick, easy, high fidelity program origination in remote broadcasting. Ideal for promotion-type shows, the turntable-console offers complete facilities to feed program material into a telephone line to the broadcast station. The unit also will allow independent control of public address facilities and can be used to drive a remote amplifier such as the Collins 212H-1.

The 808-A-1 is especially suited for combination work in a small announce booth; for schools where an economical unit but complete facilities are needed; for use in conjunction with sound systems; and for standby studio facilities at the transmitter site in case of breakdown between the studio and transmitter.

The 808A-1 eliminates the need for multiple equipments. Once on location, the unit can be plugged in, connected to a remote line and it is ready for use. It can simultaneously combine the two self-contained turntable outputs with any one of three remote inputs. Built-in phono equalization meets RIAA standards. A VU meter indicates program level, and a headphone jack is provided for program monitoring. Line terminals and microphone jacks are located on the back of the unit.

A bottom dust cover, easily removed, protects the lower portions of the turntables, cabling and amplifiers. The preamplifiers attach to the control panel, which is remov-

able as a unit for servicing. Legs are detachable and self-storing beneath the unit. The sturdy, modern-looking cabinet is made of steel with a white and gray baked enamel finish. The panel and trim strips are brushed aluminum.

Controls on the panel include the following: and external input selector switch, which will select one of the external outputs of Mike 1, Mike 2 or NEMO; motor power switches which energize the turntable motors; three cue switches which are gauged to the fader control; three separate fader controls for the three inputs; master gain, which controls the over-all output signal; ac power switch, which is gauged to the public address gain; public address gain, which allows independent adjustment of the public address or other remote systems; headphone gain; and turntable shift levers for selection of proper turntable speed of 33, 45 or 78 rpm.

The remote amplifier, made up of six low level modules and one line amplifier module, uses eight General Electric 1175A low noise transistors and two Motorola 651 push-pull Class A-B transistors. Bias is stabilized over a wide temperature range by the use of a germanium diode. The turntable preamplifiers conform to NAB and RIAA specifications and feature a feedback design which offers a consistently stable performance.

Two Collins TT-200 Turntables with Rek-O-Kut S-320 pickup arms and General Electric sapphire cartridges are furnished with the 808A-1. Specially designed for radio

broadcast use, Collins Turntables maintain 99.95% accurate speed and have negligible wow and flutter. They are mounted on a strong cast aluminum base, and precision machining is used throughout.

Frequency Response: ± 2 db, 50-15,000 cps with 1,000 cps reference.

Gain: 100 db minimum on mike input.

Balanced Inputs: Mikes 1 and 2, 50-600 ohms, -55 dbm nominal. NEMO input 600 ohms, 0 dbm nominal.

Noise: Signal-to-noise ratio, 55 db.

Distortion: 2% maximum, 50-15,000 cps at +18 dbm.

Power Output: +18 dbm (+8 VU) into 600 ohm program line. Adjustable, high impedance public address output.

Power Source: 120 v ac, $\pm 10\%$, 60 cps, 1 phase.

Size: 33 $\frac{1}{2}$ " W, 33" H (with legs), 20 $\frac{1}{2}$ " D (85.09 cm W, 83.82 cm H, 52.07 cm D).

Weight: 78 lbs. (35.38 kg).

Part No. 522 2609 00

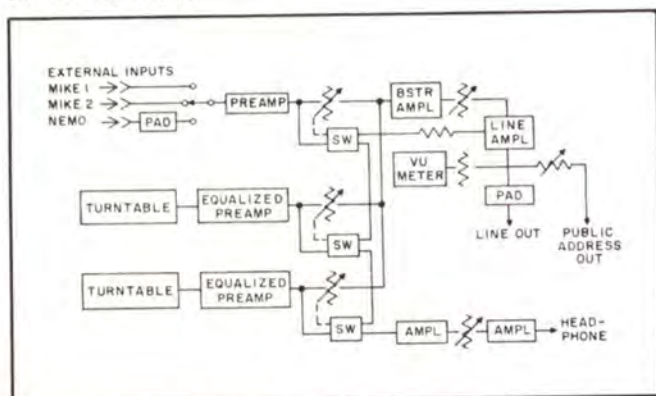

BLOCK DIAGRAM 808A-1

COLLINS 212H-1 REMOTE AMPLIFIER



The only one of its kind on the market with so many advanced and deluxe features, the Collins 212H-1 is a three channel remote amplifier that provides adequate facilities for most remote applications.

The 212H-1 is transistorized throughout and is built into a highly punishable thermoplastic and vinyl-clad aluminum case. A handle is mounted on the rear chassis to allow quick and easy handling between remote locations. A snap-on cover of durable thermoplastic protects the panel, controls and VU meter.

The unit is completely self-contained and operates from

fourteen 1.5 volt flashlight batteries. These batteries supply power to the amplifier for about 200 hours. The supply is interlocked with the headphone jack so that the unit requires headphones to be plugged in before it becomes operational. The VU meter indicates remaining battery voltage.

A built-in phono equalizer on two of three channels provides instantaneous switching between two phonos and a microphone, or between three microphones. A built-in multiple tone generator allows a quick response check of the remote line or provides a standby tone of 100, 1000 or 5000 cps. Sure-grip thumb wheels 2 $\frac{1}{4}$ " wide indicate volume input control by a diagonally moving white stripe.

Frequency Response: ± 3 db 50-15,000 cps (1000 cps reference at +8 dbm output).

Gain: 90 db nominal on mike input.

Output: Line — Normal, +8 VU (+18 dbm) into 600 ohms; Low, 0 VU (+10 dbm) into 600 ohms; Bridge — -40 dbm into 250 ohms.

Power Source: Self-contained batteries — twelve 1.5 v flashlight batteries for amplifier and two 1.5 v batteries for meter light.

Distortion: 2% maximum 50-15,000 cps +18 dbm output.

Noise: -115 dbm equivalent input noise or less (-55 dbm input, -60 db noise).

Inputs:

- | | |
|--------|---|
| One: | a. Unbalanced mike. |
| | b. Phono, equalized for magnetic cartridge. |
| Two: | a. Low impedance balanced mike. |
| | b. Self-contained tone generator. |
| Three: | a. Unbalanced mike. |
| | b. Phono, equalized for magnetic cartridge. |

Output Connectors:

- Program line, binding terminal posts.
- Bridge feed, male Cannon connector.
- Program monitor, headphone jack.

Ambient Temperature Range: -20°C to +50°C (-4°F to +122°F).

Ambient Humidity Range: Up to 95%.

Size: 10" W, 4 $\frac{1}{2}$ " H, 12" D (25.4 cm W, 11.43 cm H, 30.48 cm D).

Weight: 11 lbs. (4.99 kg).

Color: Green, white and gray.

Part No. 522 2419 00
Includes batteries.

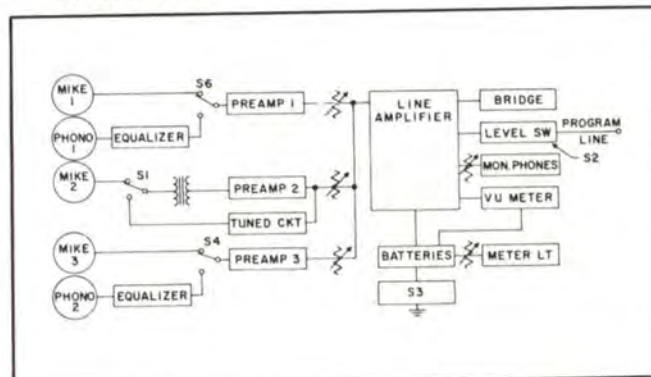

BLOCK DIAGRAM 212H-1

COLLINS 2112Z-1 REMOTE AMPLIFIER



Weighing a total of 22 pounds including batteries and carrying case, the 212Z-1 offers full functions for remote broadcasts. This transistorized remote amplifier mixes inputs from up to four microphones, with program line and communication line outputs as well as an auxiliary output for PA feed.

A power source of both 115 v ac and batteries assures uninterrupted service. Should the ac power fail, an automatic changeover switches the 212Z-1 to battery power and reverts when ac power is restored. A light on the panel indicates when the 212Z-1 operates on ac power. The self-contained batteries have a long life of about 75 hours.

The Collins 212Z-1 is attractively style—yet rugged and convenient to use. Housed in a Royalite carrying case, the 212Z-1 securely fastens to the bottom of the case. The 212Z-1 has a black and metallic blue-gray abrasion-resistant finish.

The four channel mixing circuit incorporated in the amplifier is designed to work with all microphones having a 30 to 600 ohm impedance. The output circuit matches a 600 ohm line. Provisions are made for two program lines and a telephone through the output switch.

Although simultaneous program feed and communication cannot take place over a single line at the same time, the output switch allows rapid interchange between communication and the amplifier output on the same line.

The power supply is a shielded, full-wave unit with germanium diodes and multi-section filtering. A power interlock switch insures no battery drain when the unit is in its closed carrying case.

The Collins 212Z-1 Remote Amplifier is completely transistorized throughout. The tone oscillator, preampli-

fiers and interstage amplifiers use 2N422 hermetically-sealed low noise transistors. The driver employs a 2N465 transistor. The output amplifier, with transformer coupling on the input and output sides, has push-pull 2N41 transistors.

Since line levels are most easily set up by means of a steady audio tone, the 212Z-1 includes a built-in audio tone oscillator as a standard feature.

One or two headphones may be plugged into the monitor jacks. Where loudspeaker monitoring or feed for local public address is desired, the PA terminals are used. An isolated PA feed and an individual gain control allow the operator to handle the program and simultaneously ride gain on the PA system. A multiple jack on the side permits two units to be used simultaneously and controlled by one master gain control.

Frequency Response: ±1.5 db 50-15,000 cps.

Input: 4 channels selected by Daven step-type attenuators numbered to correspond with input plugs.

Input Impedance: 30-600 ohms.

Gain: 90 db maximum.

Noise Level: 55 db below normal output level.

Distortion: Less than 1½% at +5 dbm.

Power Output: Normal +11 dbm; emergency +16 dbm.

Output Impedance: 600 ohms (150 ohms available).

Power Source: 115 v or 230 v ac 50/60 cps or self-contained batteries, such as one 4.5 v Burgess D-3 or Eveready 726, and two 22.5 v Eveready 763. Life of 22.5 v battery is approximately 75 hours; 4.5 v approximately 90 hours. (Batteries not supplied with unit.)

Microphone Connections: 4 Cannon XL-3-13N.

Ambient Temperature Range: 0°-45°C.

Ambient Humidity Range: Up to 95%.

Size: 15½" W, 6½" H, 14½" D (39.37 cm W, 16.51 cm H, 36.83 cm D).

Weight: 22 lbs. (9.98 kg) (with batteries).

Part No. 522 0330 003
212Z-1 without batteries.

Part No. 015 0520 00 (Type 763)
Two batteries required in addition to one Type 726 battery (below).

Part No. 015 0519 00 (Type 726)
One battery required in addition to two Type 763 batteries (above).

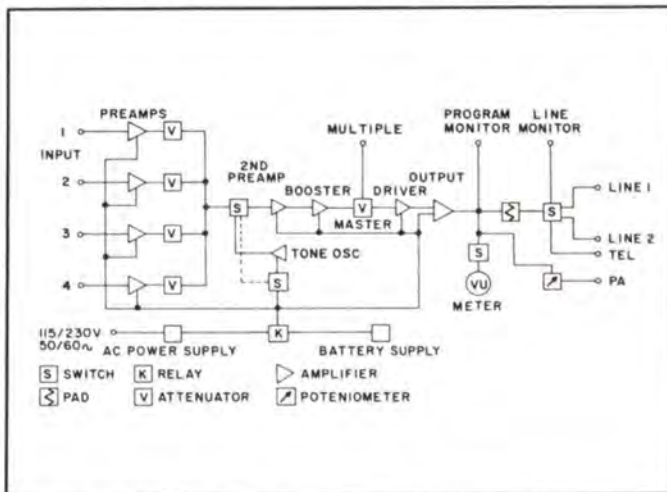

BLOCK DIAGRAM 212Z-1

MARTI REMOTE PICK-UP EQUIPMENT

Marti Remote Transmitter and Receiver provide quality transmission of sports, spot news reports and interviews on frequencies assigned for exclusive use by broadcasters. The unit is compact and light enough to be carried into stadiums and press boxes as easily as a multi-channel remote amplifier.

The audio quality of the Marti for music or voice transmission is guaranteed to be equal to or better than lines with coverage up to 40 miles radius depending upon the type and location of the transmitting and receiving antennas. The Marti Receiver is equipped with an automatic relay that operates an alarm system in the station to indicate a forthcoming broadcast.

The unit may legally be used instead of lines even where lines are available. Many stations, after installing the Marti system, have standing sponsorship of all their remote programs and have actually paid for the equipment in savings on line charges alone. The equipment also opens new program possibilities that are overlooked because of inconvenience in using other, cumbersome and less reliable means.

The Marti Transmitter is operated either by ac or batteries. Designed for continuous duty, the equipment meets the most stringent FCC requirements regarding bandwidth.

It is easily portable and lightweight and does not require frequent tuning. The transmitter and transistorized power supply and associated equipment are easily installed in a car for permanent and immediate use.

MARTI M-25C REMOTE PICK-UP



The M-25C is a 25 watt base station transmitter for communication with mobile units operating in the 144 to 174 megacycle range. The unit provides frequency stability of $\pm .0005\%$ within a temperature range of minus 30 degrees C to plus 60 degrees C. The modulation characteristic is adjusted at the factory for ± 7.5 kc for 100% modulation at 1000 cycles.

RF Output: 25 watts, Intermittent (EIA).

Frequency: 144 to 174 megacycles.

Crystal Multiplication: 36 times.

Spurious Emission: Spurious Radiation attenuated at least 70 db below carrier level. Harmonics suppressed at least 60 db.

Audio Inputs: Two (2). One for local control, a carbon microphone. Other for remote control, a two-wire telephone line.

Remote Control Facilities: Built-in line termination unit.

Power Requirements: 117-123 v ac 50-60 cps.

Duty Cycle: Intermittent (EIA).

Frequencies Possible: two; maximum spacing 120 Kcs.

Metering: Multiple pin test socket.

Tube Complement: Two 6BL8; one 7059; one 6360-A; & one 8150.

Power Supply: Silicon rectifiers.

Dimension: 10 $\frac{1}{2}$ " x 19" (standard relay rack mounting).

MARTI MR-30/150 = 170 RECEIVER



The MR-30/150-170 receiver is used for remote pick-up from a base station operating in the 150 to 174 megacycle range. The receiver is sensitive to 0.6 microvolts or less for 20 db quieting, and is selective to -100 db at ± 32 kc; -6 db or less at ± 15 kc.

Application: Remote Pickup.

Frequency Range: 150 to 174 megacycles.

Spurious Response: All spurious and image responses attenuated at least 100 db.

Overall Response: ± 2 db, 60 to 7500 cps with matching transmitter.

Frequency Stability: $\pm 0.0005\%$ with crystal oven.

Temperature Range: -40°C to +70°C.

Audio Output: +8 VU at 600 ohms.

Metering: Signal strength and VU brought out to test Jacks. Visual metering optional.

Tube Complement: 15 required. 8 tube types.

6DS4—1st RF Amp. (Nuvistor)

6DS4—2nd RF Amp. (Nuvistor)

6DS4—1st Mixer (Nuvistor)

6DS4—HF Osc. Trip. (Nuvistor)

6HS6—1st IF Amp.

12AT7—2nd Mixer & LF Osc.

6HS6—2nd IF Amp.

6HS6—3rd IF Amp.

6BH6—1st Limiter

6BH6—2nd Limiter

6AL5—Discriminator

12AX7—Noise Amp.

12AT7—Noise Rect. & Relay Amp.

6CG7—Audio Amp.

OB2—Voltage Reg.

Dimensions: 10 $\frac{1}{2}$ " H, 19" W, 9" D. Panel finish — WE hammertone grey.

Weight (net): 20 lbs.

TPS-1 POWER SUPPLY

Input Voltage: 12-16 v dc.
Current: Standby — 6 amps; transmit — 13 amps.
Outputs: 6.3 v, 6 amps (regulated). 330 v ac to the rectifier system.
Duty Cycle: Continuous.
Efficiency: Approximately 85%.
Size: 17" W, 6" H, 3 3/8" D (43.18 cm W, 15.24 cm H, 8.57 cm D).
Weight: 7 1/2 lbs. (3.2 kg).
Part No. 097 6653 00 (Type TPS-1)

MARTI REMOTE EQUIPMENT ACCESSORIES

MOBILE ASSEMBLAGE — Consists of control unit, all battery and control cables and mounting rack for the M-30B/TPS transmitter (Type TPS-TC).

Part No. 099 0541 00

REMOTE CONTROL CONSOLETTTE — For use with M-30B or M-30B/11RS-2R (Type RMC-1). Constructed of wood cabinet and aluminum anodized front panel, complete with VU meter.

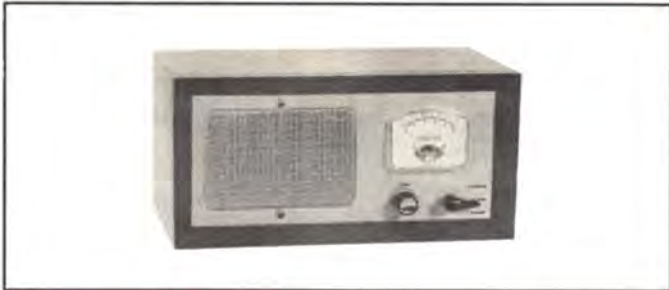

Size: 14" W, 9" H, 10" D (35.56 cm W, 22.86 cm H, 25.4 cm D).

Part No. 099 0542 00

The following antennas are tuned or cut to frequency with a standing wave ratio of less than 1.5:1 and are designed for 50-52 ohm transmission lines.

SINGLE RING ANTENNA — Essentially non-directional, horizontally polarized and unity gain.



Specify whether for portable (PA-1) or mobile (MA-1) use.

Part No. 097 6952 (Type PA-1)
Part No. 097 6953 (Type MA-1)

TWO RING ANTENNA — Essentially non-directional, horizontally polarized. Has a gain of 3 db (Type RA-2).
Part No. 099 0543

ANTENNA BUMPER MOUNT — Chain link bumper mount (Type ASP-143) for use with mobile antenna.

Part No. 097 6880 00

FOUR RING ANTENNA (TYPE RA-Y) — Essentially non-directional, horizontally polarized. Has a gain of 6 db and power gain of 4.

Impedance: 52 ohms.

Weight: 11 lbs.

Part No. 097 6950

FIVE ELEMENT YAGI ANTENNA (TYPE YC) — Unidirectional antenna.

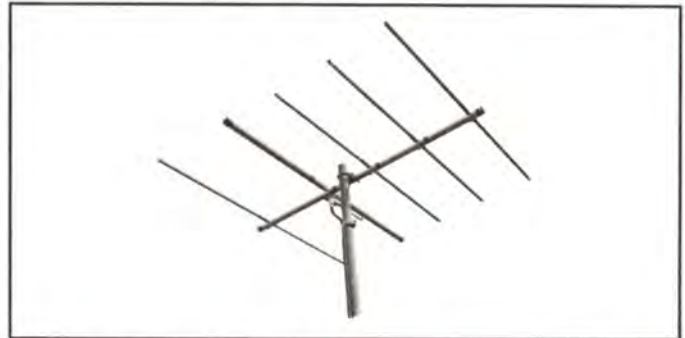

Nominal Impedance: 50 ohms.

Average Gain: 9 db.

Typical VSWR: Under 1.5.

Typical Rear Signal Rejection: 25 db.

Power Handling Capacity: 60 watts.

Input Connector: Type AN-SO-239 (Amphenol Type 83-1R).

Polarization: Horizontal or vertical.

Part No. 099 0177

COAXIAL STACKING HARNESS — Required for stacking two, five element Yagi antennas. It is made up of two sections of RG-11/U 75 ohm coaxial cable joined at the center by a coaxial "T" fitting. Each "half" of the phasing harness is an odd multiple of a quarter wave length and by virtue of its characteristic impedance and length, steps the 50 ohm antenna impedance to 100 ohms. When the two cables are joined at the "T" connector, the impedance again becomes 50 ohms (Type 2YC).

Part No. 099 0190

KREKO VERTICALLY POLARIZED ANTENNA — This vertically polarized base antenna has a gain of 6 db (Type SC-155-B).

Part No. 099 0544

VEHICLE ROOFTOP ANTENNA — Designed especially for mounting on a vehicle, this antenna has a 3 db gain (Type ASP-177).

Part No. 099 0545

COAXIAL CABLE AND CONNECTORS — The following coaxial cables and connectors may be used with the Marti Remote Pick-Up Equipment:

Part No. 099 0146

RG 8/U coaxial cable, 100'.

Part No. 099 0137

RG 17/U coaxial cable, 100'.

Part No. 099 0546 00

RG 8/U connector PL-259 (Type 83-1SP).

Part No. 099 0547 00

RG 8/U straight adapter PL-258 (Type 83-1J).

Part No. 099 0548 00

RG 17/U to RG 8/U connector (Type GR-6355).

Part No. 097 7023

RG 253/U Spir-O-line cable, 1/2", polyethylene jacketed, 100'.

Part No. 099 0549 00

Spir-O-line RG 253/U to PL-258 connector (Type 87-500).



MEASURING, MONITORING, REMOTE CONTROL



METRON 506B AMPLITUDE MODULATION MONITOR

Occupying only 5¼ inches of rack space, the fully transistorized Metron 506B Amplitude Modulation Monitor continuously measures modulation of the AM r-f carrier.

Meeting or exceeding FCC requirements, the 506B mounts in any standard 19-inch rack or cabinet. Frequently used controls are conveniently located on the front panel together with two easy-to-read illuminated meters for monitoring carrier level and percentage modulation.

Modulation peaks are indicated by a flashing lamp. Flashing level is adjustable from 0 percent to 100 percent modulation. Lamps operate at 60 percent of rated voltage to assure long life.

All external connections are made at the back of the unit. The r-f input may be made to either a coaxial receptacle or barrier type terminal strip. A remotely controlled modulation meter and/or remote flasher may be connected to terminals provided and may be switched in or out at will without affecting circuit calibration.

Two auxiliary audio outputs are provided. One of these is a high impedance, high level output for fidelity measurement; the other feeds a 600-ohm audio monitoring circuit.

Input impedance: 75 ohms

Frequency range: 0.5 to 1.6 mc

R-f power required: 0.5 watts (6 to 20 v rms)

Power requirement: 105 to 125 v a-c, 50 to 60 cycles, 10 watts

Dimensions: W 19", H 5¼", D 5" (W 48.26 cm, H 13.34 cm, 12.7 cm)

Weight: 10 lbs. (4.54 kg)

MODULATION PERCENTAGE METER

Accuracy: ±2% of full scale, modulating frequency 1000 cps

Response: ±0.3 db, 30 cps to 100 kc

±0.1 db, 100 cps to 30 kc

MODULATION PEAKS FLASHER

Range: Continuously adjustable, 0% to 100%

Flash point: Flashes when negative modulation exceeds dial set point by more than 2%

Accuracy: ±2% of full scale, 30 to 15,000 cps

AUDIO MONITORING OUTPUT

Response: ±0.5 db, 30 cps to 100 kc

Distortion: Less than 0.2%, 600-ohm load

Output voltage: 0.5 v rms, 100% modulation with 600-ohm load

FIDELITY MEASURING OUTPUT

Response: ±0.5 db, 30 cps to 100 kc

Distortion: Less than 0.1%, 600-ohm load

Hum and noise level: At least 80 db below 1.5-v rms signal level

Output voltage: 3.5 v rms at 100% modulation with load resistance exceeding 100,000 ohms shunted by capacitance of less than 500 mmf.

Part No. 099 300 000

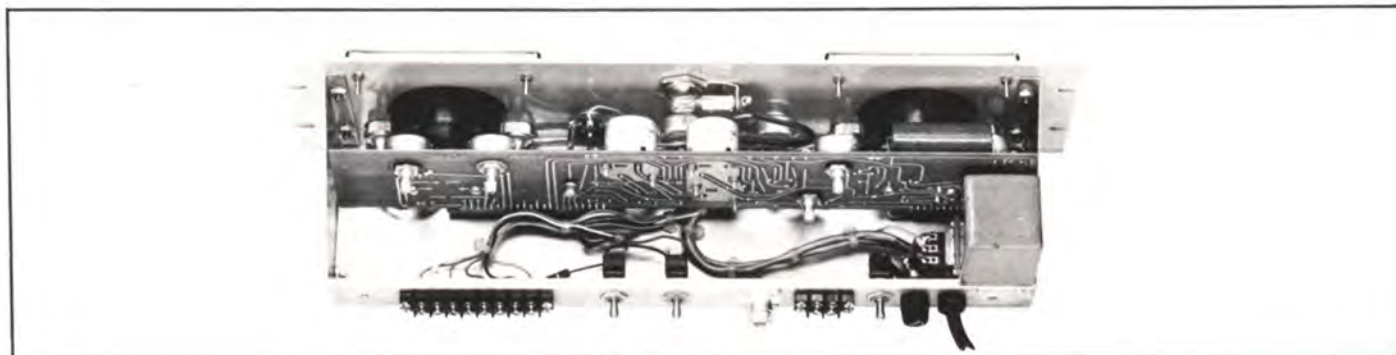

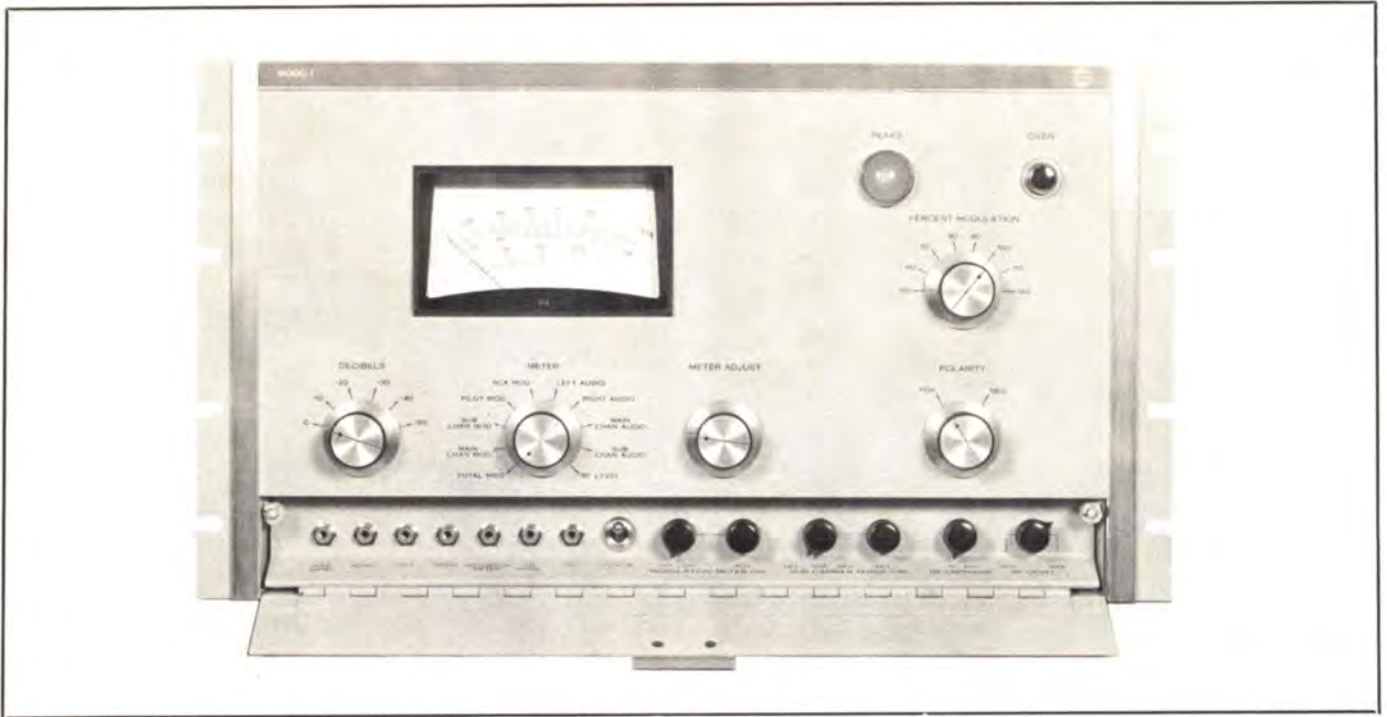

COLLINS 900C-1 FM STEREO MODULATION MONITOR

The versatility of the 900C-1 is highlighted by these capabilities:

- Total peak frequency deviation measurement.
- Individual modulation component deviation measurement.
- Stereo signal demodulation for channel separation measurement.
- Channel cross-talk measurement.
- Both monaural and stereo outputs for monitoring and proof-of-performance as required.
- Wideband output for visual proof of separation with oscilloscope.
- AM noise level output for VTVM measurement.
- Test points for pilot carrier frequency measurements.

Versatile and dependable, the Collins 900C-1 FM Stereo Modulation Monitor assures the broadcaster accurate measurement and monitoring of FM stereo multiplex programming in accordance with FCC standards.

Fully transistorized, the unit uses a minimum of primary power, has low heat dissipation and is carefully engineered and manufactured to assure long life through the use of conservatively-rated components.

Plug-in wired circuit cards not only enhance the unit's flexibility and versatility but also speed up fault isolation and maintenance, keeping down-time to a bare minimum.

The 900C-1 has proper phase and frequency response, reads peak values of complex audio signals and has the necessary demodulation circuits. These requirements are not met by monaural monitors, even with modification.

The 900C-1 provides the demodulating circuitry required not only to measure total peak frequency deviation

of the carrier in the 50 cycle to 75 kilocycle range but also to measure deviation caused by the different bands of modulating frequencies: main channel, stereo subchannel, pilot carrier and SCA subchannel.

Total modulation is measured with the peak light and meter; individual modulation components are checked by the meter alone. A self-contained voltmeter is used for direct measurements of channel separation, cross-talk and signal-to-noise ratio.

Careful attention to engineering design and excellence in manufacturing, traditional at Collins, make the 900C-1 an invaluable tool for the current needs of FM and stereo broadcasters.

Referring to the block diagram, the signal flow is as follows:

The input RF is attenuated and mixed with the output of an oscillator-tripler which has an output frequency 500 kc above the input signal carrier frequency.

The 500 kc intermediate frequency is coupled through an isolation stage to a limiter and pulse counter which delivers constant area pulses to a phase linear low pass filter. The filter's output is the wideband audio containing all frequencies between 50 cps and 75,000 cps which are modulating the transmitted carrier. At this point the audio is fed to the modulation metering and stereo demodulator circuits.

In the modulation metering circuit, the wideband audio is fed to a phase splitter which delivers two outputs of opposite phase. One of these, selected by the front panel modulation polarity switch, is fed to the peak light circuit and the true peak reading voltmeter circuit.

Switched filters in the audio path break up the total modulation into the four different bands: main channel, stereo subchannel, pilot carrier and SCA subchannel.

In the stereo demodulator circuit, the audio signal from the phase linear low pass filter has the 19 kc pilot carrier separated, doubled to 38 kc and amplified to a level capable of driving the switching diodes. The switch breaks the composite signal into left and right output signals and amplitude correction is made by cross-coupling left and right outputs. The two outputs are filtered to remove all frequencies above 15 kc and then are identically amplified to provide left and right signals.

A built-in calibration circuit assures proper phasing of the regenerated 38 kc subcarrier as required for accurate stereo demodulation.

MODULATION METER SECTION

Meter Positions: Total modulation, main channel modulation, stereo subchannel injection, pilot carrier modulation, SCA subchannel injection.

Meter Range: 0%-133% for total, main and stereo subchannel modulation. 0%-30% for pilot carrier and SCA subchannel injection.

Accuracy: 5% over entire scale.

Meter Characteristics: Rise time, decay time and damping factor as prescribed by FCC for FM monaural monitors (all meter positions).

Frequency Response: ±0.5 db from 50-75,000 cps.

Calibration: Self-contained calibrating signal source.

External Meters: Provisions for adding series meter in short line (100 foot maximum) or remote meter in telephone line (5000 ohm maximum loop resistance).

PEAK LIMIT INDICATOR LIGHT

Range: Threshold adjustable from 50%-120% modulation.

Response: Will flash on modulation peaks of 20 milliseconds duration or greater.

External Indicators: Provision included for external peak limit indicator light.

MONAURAL AUDIO SECTION

Outputs: 0 dbm unbalanced (600 ohm flat or de-emphasized). 10 v rms across 10,000 ohms (flat or de-emphasized).

Frequency Response: ±0.5 db from 50-15,000 cps or within 1.0 db of standard 75 microsecond de-emphasis curve.

Distortion: 0.25% max. 50 cycles per second to 15 kc at 100% modulation.

Signal-to-Noise Ratio: 75 db.

STEREOPHONIC AUDIO SECTION

Outputs: 0 dbm unbalanced (600 ohms flat or de-emphasized). Distortion meter output: 10 v rms across 10,000 ohms unbalanced.

Frequency Response: ±1 db from 50-15,000 cps or within 1.0 db of standard 75 microsecond de-emphasis curve.

Distortion: .5% max. from 50-15,000 cps at 90% modulation.

Signal-to-Noise Ratio: 55 db on self-contained voltmeter. *Channel Separation:* 40 db from 50-15,000 cps. Read on self-contained audio voltmeter.

Channel Cross-Talk: 45 db. Read on self-contained audio voltmeter.

Stereophonic Subcarrier Suppression: 60 db. Read on self-contained audio voltmeter.

Pilot Carrier Phasing: Transmitter pilot carrier phasing adjusted for proper 0 crossing after calibration of stereophonic subcarrier regeneration in monitor.

GENERAL

RF Input: 4-10 v rms at 50 ohms. Input on rear of unit. *Outputs:*

Rear Chassis—Left Channel, Right Channel, Monaural, Remote Meter, Remote Peak Indicator, Wideband Output, IF (500 kc) Output for Frequency Meter, and 19 kc Output (for frequency measurement).

Front Panel—Wideband Output, Monaural Audio Output, Left Audio Output, Right Audio Output, Distortion—Measurement Output, 38 kc, 19 kc, and AM Noise Measurement Output.

Controls:

Front Panel—Function Selector, Voltmeter Reference Adjust, Voltmeter Range Adjust, Peak Indicator Threshold Adjust, Modulation Polarity Select.

Subpanel—Modulation Meter Calibrate Switch, Modulation Meter Calibrate Adjust, Subcarrier Phase Calibrate Switch, Subcarrier Phase Calibrate Adjust, De-emphasis Switch, RF Input Level Adjust, and Power On-Off.

Size: 19" W, 10½" H, 13-25/32" D (48.26 cm W, 26.67 cm H, 33.02 cm D).

Weight: 35 lbs. (15.88 kg).

Primary Power: 120 v or 240 v ±10%, 50-60 cps. 50 watts.

Part No. 522 3275 000

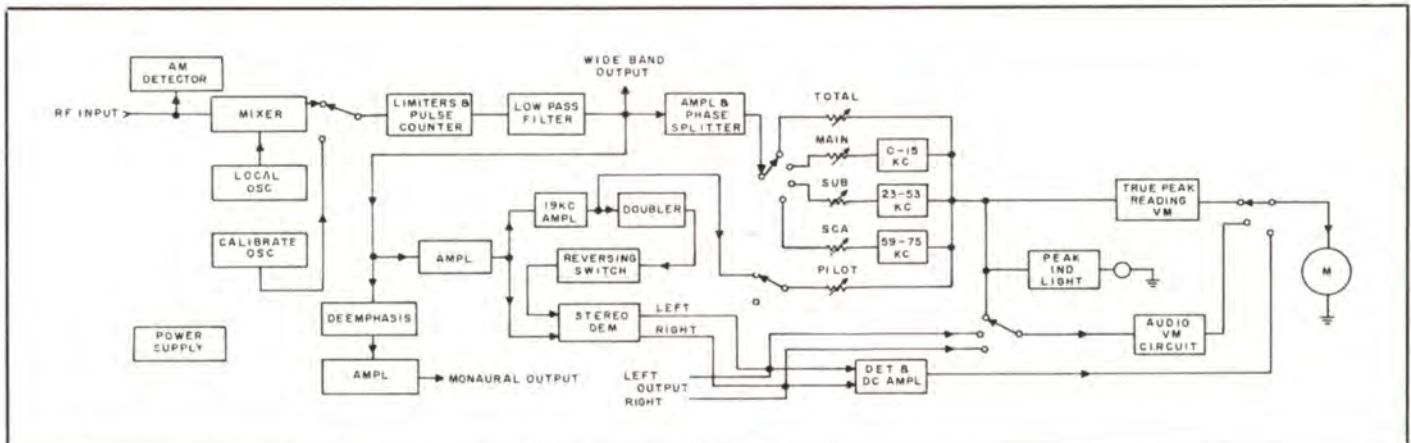

BLOCK DIAGRAM 900C-1

McMARTIN FM FREQUENCY AND MODULATION MONITORS

The McMARTIN TBM-3000 and TBM-3500 are another first . . . a completely self contained frequency monitor and separate self contained modulation monitor, each independent of the other. These are the first and only monitors to comply with present FCC requirements.



McMARTIN TBM-3000 FM FREQUENCY MONITOR FEATURES:

- Type Approval Number 3-113
- Single purpose frequency monitor
- Completely self contained
- Accuracy .001%
- Unaffected by modulation
- External metering available
- Reliable double regulated silicon rectifier power supply
- Special meter for good visibility

Frequency Range: 88 to 108 mc — fixed

Deviation Range: +4 kc to -4 kc of specified frequency

Accuracy: Better than .001% or better than 1000 cps @ any frequency

Stability: 75 to 150 cps within 24 hours

RF Input: 1 to 5 volts @ 50 ohms — 1/2 watt maximum

Front Panel Indicators: Modulation meter, AC power—neon. Crystal oven—6 v. incandescent

Front Panel Controls: Selector switch: RF input, calibrate, operate, meter zero, crystal tuning, power on-off

Chassis Controls: RF level

Outputs: Provisions for external remote meter (optionally available)

Tubes & Diodes: 3—6201; 2—6265; 1—5814A; 1—OB2; 1—OA2; 4—1N56

Rectifiers: 4 silicon 750 ma/600 v.

Power Supply: 100-130VAC; 55 watts; 50-60 cps; C.C.S.; double; regulation; fused

Dimensions: Standard rack 19" width x 8 3/4" height x 7 1/2" depth (behind panel)

Shipping weight: 18 lbs.

Part No. 099 2309 000

Type No. TBM 3000



McMARTIN TBM-3500 FM MODULATION MONITOR FEATURES:

- Self contained single purpose modulation monitor
- Accuracy 1/2 db, 50-75,000 cycles
- External metering available
- High speed indicator reads 10 millisecond peaks
- Measures all modulation carried by FM transmitter, including subchannels
- Measures separately main channel audio modulation without subchannels
- Output provisions for stereo and SCA monitors and proof-of-performance tests

Operating Range: Main Channel 88 to 108 mc

Modulation Range: Full scale meter deflection indicates deviation of ±100 kc or 133% modulation. Scale calibration indicates 100% modulation @ ±75 kc.

Metering Accuracy: Within 5% over entire scale (FCC standard for FM)

Meter Characteristics: Well within FCC requirements. Pointer reaches 90% value of a modulation peak, with a duration of only 70 milliseconds. Overshoot is less than 3%. Meter decays from full reading to 10% of value in 720 milliseconds.

Peak Flash Indicator: Responds to modulation peaks with a duration of 10 milliseconds or less.

Frequency Response (Meter & Flasher): ±1/2 db; 50 cps to 75 kc @ 100% modulation

Stability: Maintained by special inverse feedback.

Audio Frequency Range: Follows FCC de-emphasis curve. ±1.0 db 50 to 15,000 cps.

Audio Distortion: Main Channel—0.5% 50 to 15,000 cps

Audio Hum and Noise: Main Channel—65 db below 100% modulation @ low audio frequencies

RF Input: 1 to 5 volts @ 50 ohms (1/2 watt max.) coaxial input

Front Panel Indicators: 1) Main channel modulation peak flasher (neon)
2) AC power (neon)

Front Panel Meters: 1) Main channel modulation (RF input—total modulation—main channel modulation)

Front Panel Controls: 1) AC power on-off

2) Main channel modulation meter function switch

3) Main channel ±modulation polarity switch

4) Main channel peak modulation flasher control

Rear Chassis Controls: RF attenuator

Outputs (front panel): 1) Main Hi-Z phone jack

Outputs (rear chassis): 1) External main channel modulation meter
 2) Multiplex
 3) Main channel audio Hi-Z
 4) Main channel audio 600 ohms

Tubes: 12—Types: 2—12AT7; 1—6BH6; 2—6AK5; 1—12AX7; 1—6BE6; 1—6EM7; 1—2D21; 1—OB2; 1—6AB4; 1—7581

Diodes: 3 (1N51)

Fuse: 1—1 Amp SB-3AG

Rectifiers: 4 type 1N2095 Silicon

Power Supply: 100-130VAC; 55 watts; 50-60 cps; C.C.S.; double; regulation; fused

Dimension: Standard rack 19" width x 8³/₄" height x 7¹/₂" depth (behind panel)

Shipping weight: 18 lbs.

Part No. 099 2308 000

Type No. TBM 3500

McMARTIN FM MODULATION — SCA MULTIPLEX MONITOR



Drawing on their experience as the nation's leading manufacturer of multiplex receivers, McMARTIN engineers have developed an exceptional instrument which can measure all main channel modulation characteristics as well as all SCA-multiplex operating characteristics.

FEATURES:

- Self contained independent Modulation Monitor, measures all modulation carried by the FM transmitter.
- Separate metering for direct reading of main channel modulation.
- Provisions for measuring all characteristics of one or two subchannels separately.
- Instantaneous direct reading of either subchannel injection at any time.
- Continuous metering of either subchannel frequency.
- Continuous metering of either subchannel modulation. Referred to either 5 or 7.5 kc deviation.
- Subchannel metering characteristics identical to main channel requirements as outlined by FCC.
- Direct reading of noise or crosstalk on either subchannel from any source without auxiliary equipment.

- Audio output of both main channel and either sub-channel available for aural monitoring and proof of performance checks.
- Separate high speed main and sub peak modulation lamps respond to 10 millisecond peaks.
- Automatic subchannel muting.
- Output terminals for external subchannel failure alarm.
- Output terminals for main channel and subchannel modulation extension meters.
- Reliable double regulated silicon rectifier power supply.
- Total modulation output jack to feed either McMARTIN TBM-2000 (separate SCA-multiplex monitor) or TBM-4500 (stereo monitor).

SPECIFICATIONS

Operating Range: Main Channel 88 to 108 mc. SCA Multiplex 25 to 75 kc.

MAIN CHANNEL MODULATION

Modulation Range: Full scale meter deflection indicates deviation of ± 100 kc or 133% modulation. Scale calibration indicates 100% modulation @ ± 75 kc.

Metering Accuracy: Within 5% over entire scale (FCC standard for FM).

Meter Characteristics: Well within FCC requirements. Pointer reaches 90% value of a modulation peak with a duration of only 70 milliseconds. Overshoot is less than 3%. Meter decays from full reading to 10% of value in 720 milliseconds.

Peak Flash Indicator: Responds to modulation peaks with a duration of 10 milliseconds or less.

Frequency Response (Meter & Flasher): $\pm 1/2$ db; 50 cps to 75 kc @ 100% modulation.

Stability: Maintained by special inverse feedback.

SCA MULTIPLEX MODULATION

Modulation Range: 100% modulation on the meter scale may correspond to deviation of ± 5 kc or ± 7.5 kc as desired. Selection is made by a front panel switch. 133% modulation (full scale) corresponds to deviation of ± 6.67 kc or ± 10 kc.

Metering Accuracy: Same as main channel specifications above.

Meter Characteristics: Same as main channel specifications above.

Peak Flash Indicator: Responds to modulation peaks with a duration of 10 milliseconds or less.

Frequency Response (Meter & Flasher): $\pm 1/2$ db; 50 to 7500 cps @ 100% modulation.

Stability: Maintained by special inverse feedback.

SCA MULTIPLEX FREQUENCY

Operating Range: Any two SCA multiplex subcarriers between 25 kc and 75 kc by front panel selector switch.

Deviation Range: Zero center scale is calibrated to ± 4000 cps ($\pm .004\%$ of 67 kc).

Accuracy: Better than 100 cps at 67 kc.

Stability: Maintained by crystal with .005% tolerance.

SCA MULTIPLEX INJECTION

Injection Percentage: A separate circuit and meter scale indicates the maximum allowed (FCC) modulation percentage of the main carrier by SCA subcarriers. 30% injection corresponds to about 2/3 of full scale reading.

Accuracy: Within 5% over entire scale.

CROSSTALK & SIGNAL-TO-NOISE RATIO

Metering: Reads crosstalk and S/N ratio of SCA multiplex channel to -65 db with calibrated scale and step attenuator. Measures crosstalk of main into SCA, SCA and/or stereo into SCA.

AUDIO

Frequency Range: Main Channel — Follows FCC de-emphasis curve. ± 1.0 db 50 to 15,000 cps.

SCA Channel — 75 microsecond de-emphasis ± 1.0 db 50 to 7500 cps.

Distortion: Main Channel — 0.5% 50 to 15,000 cps.

SCA Channel — 1.0% 50 to 7500 cps.

Hum and Noise: Main Channel — -65 db below 100% modulation @ low audio frequencies.

SCA Channel — -65 db below ± 7.5 kc deviation @ low audio frequencies.

GENERAL

RF Input: 1 to 5 volts @ 50 ohms ($\frac{1}{2}$ watt max.) coaxial input.

Front Panel Indicators: 1) Main Channel modulation peak flasher (neon).

2) SCA modulation peak flasher (neon).

3) AC power (neon).

Front Panel Meters: 1) Main channel modulation (RF input — total modulation — main channel modulation — sub-channel injection).

2) Subchannel frequency (reads selected subchannel).

3) Subchannel modulation, crosstalk, S/N.

Front Panel Controls: 1) AC power on-off.

2) Main channel modulation meter function switch.

3) Main channel \pm modulation polarity switch.

4) Main channel peak modulation flasher control.

5) Subchannel frequency meter function switch.

6) Subchannel frequency meter calibrate control.

7) Subchannel peak modulation flasher control.

8) Crosstalk, S/N step attenuator.

9) SCA deviation selector 5 or 7.5 kc.

Rear Chassis Controls: RF attenuator.

Outputs (front panel): 1) Main Hi-Z phone jack.

2) SCA Hi-Z phone jack.

Outputs (rear chassis): 1) External main channel modulation meter.

2) External SCA channel modulation meter.

3) Multiplex.

4) Main channel audio Hi-Z.

5) Main channel audio 600 ohms.

6) Subchannel audio Hi-Z.

7) Subchannel audio 600 ohms.

8) Subchannel failure relay (for alarm).

Tubes: 24.

Types: 4—12AT7 1—6SN7

4—6BH6 1—6U8

2—6AK5 2—2D21

3—12AU7 2—OA2

1—6BE6 1—OB2

2—6AB4

Diodes: 14 (1N51).

Fuse: 1 — 1 Amp SB-3AG.

Rectifiers: 4 type 1N2095 Silicon.

Power: Constant regulated voltage transformer 105-125 volts, 60 cycle AC 65 watts Gaseous regulator type tubes.

Dimensions: Panel — standard rack 10 $\frac{3}{4}$ " x 19".

Chassis — 13 $\frac{1}{2}$ " behind panel.

Weight: 34 lbs.

Part No. 099 0824 — (Type No. TBM-4000)

McMARTIN RF AMPLIFIER

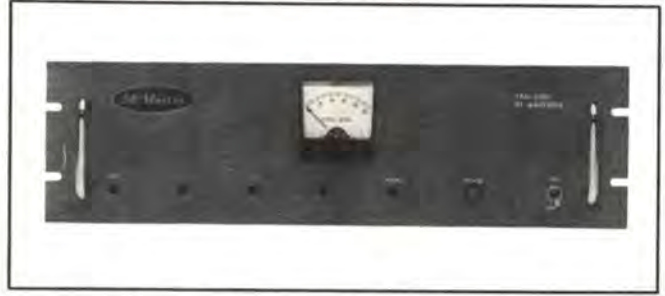

The McMARTIN TBM-2500 RF Amplifier is used in conjunction with any McMARTIN TBM series FM station monitor when remote operation is necessary. It will also operate with other brands of monitors which require a higher input power level. It will feed a combination of high and low input level monitors.

FEATURES:

- Complete alignment from front panel
- Relative signal level meter
- Carrier failure relay for alarm circuit
- Complete circuit shielding
- Antenna (cut-to-frequency, 4 elements) & 50' coaxial cable supplied
- Stable, non-critical design
- Exceptionally long tube life

SPECIFICATIONS:

Operating range: 88-108 mc.

RF Sensitivity: 300 uv input for $\frac{1}{2}$ watt output. 1000 uv input for 2 watt output.

Input: 50 ohms coaxial.

Outputs: (2) 50 ohms coaxial.

Dimensions: 19" wide, 5 $\frac{1}{4}$ " high, 7" deep.

Finish: Natural gray panel.

Power: 120 VAC, 50-60 cps, 45 watts.

Part No. 099 2502 — (Type TBM-2500)

BARKER & WILLIAMSON 210 AUDIO OSCILLATOR

Resistance capacitance type for making frequency response, distortion and other audio measurements.

Ranges: 30-300, 300-3,000, 3,000-30,000 cps.

Output: 10 v into 500 ohm load. Less than 1% rms harmonics 30-15,000 cps with 500 ohm load.

Response: Better than ± 1 db 30-15,000 cps.

Calibration Accuracy: 3% of scale reading.

Size: 13 $\frac{3}{4}$ " W, 9 $\frac{1}{2}$ " H, 7 $\frac{1}{4}$ " D (34.93 cm W, 24.13 cm H, 18.42 cm D).

Shipping Weight: 17 lbs. (7.71 kg).

Part No. 099 0827 00

NEMS-CLARK 120-E FIELD INTENSITY METER

A lightweight instrument for the measurement of a wide range of radio signal intensities.

Frequency Range: 540-1600 kc.

Field Intensity Range: 10 mv/meter to 10 v/meter.

Accuracy of Attenuators: 2%.

Output Indicator: Direct reading panel meter.

Antenna: Shielded, unbalanced loop.
Power Requirements: Batteries, five 1½ v, two 67½ v (provisions for external supply).
Size: 13" W, 9" H, 5¾" D (33.02 cm W, 22.86 cm H, 14.61 cm D).
Weight: 12½ lbs. (5.67 kg) with batteries.
Part No. 097 5516 000

NEMS-CLARK 121 ACCESSORY UNIT

Designed as a companion unit to the 120-E (also 120-D, WX-2A, WX-2B, WX-2C and WX-2D). Its principal function is to operate 1 ma recorders of the Esterline Angus type to give a permanent record of field strength. It can also be used as a general purpose recording and monitoring amplifier when a high input impedance is desired and 5 v dc is available.
Input Required: Approximately 5 v dc.
Output: 1 ma into loads up to 2,000 ohms.
Speaker: 4" panel mounted.
Power Source: 117 v, 50-60 cps, or 6 v dc.
Power Input: 15 watts ac or 2.5 amps dc.
Size: 12½" W, 6½" H, 4½" D (31.75 cm W, 16.51 cm H, 11.43 cm D).
Weight: 10 lbs. (4.54 kg).
Part No. 099 0370 000

NEMS-CLARK 108 PHASE MONITOR



Provides an indication of the phase relations in directional antenna systems, and is tailored for the particular installation. It usually incorporates provision for indicating the relative amplitudes of the currents in the various antennas, as well as the phase relation. Specify requirement for monitoring 2, 3, 4, or over 4 elements.
Frequency Range: 100 kc to 2 mc.
Phase Angle Range: 0° to 360°.
Monitoring Accuracy: 1°.
Resolution: ½°.
RF Input Impedance: 50 or 70 ohms nominal.
RF Voltage Range: 1-7 v.
Tubes: Two 6AU6, two OB3, one 5Y3 and three 6AL5.
Power Requirements: 105-125 v, 80 watts.
Size: 19" W, 14" H, 7" D (48.26 cm W, 35.56 cm H, 17.78 cm D).
Weight: 20 lbs. (9.07 kg).
Part No. 099 0366 000 (2 element)
Part No. 099 0367 000 (3 element)
Part No. 099 0368 000 (4 element)
Part No. 099 0369 000 (over 4 element)

BARKER & WILLIAMSON 410 DISTORTION METER



Ideal for FCC proof of performance tests and general laboratory use in measuring audio distortion, noise level and ac voltage level, the B & W 410 operates over a wider frequency range and provides increased sensitivity than earlier models.

The distortion meter measures distortion on fundamental frequencies from 20-20,000 cps and indicates harmonics up to 100,000 cps. Distortion levels as low as 0.1% can be indicated and measurements may be made on signal levels of 0.1-30 v rms. Distortion ranges provided are 1% full scale, 3%, 10%, 30% and 100% (full scale). The unit is designed for optimum accuracy on 600 ohms but is satisfactory on sources up to 100,000 ohms.

The 410 voltmeter input impedance is 1 megohm, and it has an accuracy of ±5% on measurements from 0.0005-300 v. Residual noise is less than 0.02 mv. For noise and db measurements, the unit is calibrated in 1 db steps from 0 db to -15 db. The attenuator provides additional ranges from -60 db to +50 db in 10 db steps.

The chassis, panel and case are of aluminum and attractively styled and finished in two tone gray.
Size: 11¼" W, 9" H, 8" D (28.58 cm W, 22.86 cm H, 20.32 cm D).
Weight: 11 lbs. (4.99 kg).
Part No. 099 0569 000

GENERAL RADIO 1181-B FREQUENCY DEVIATION MONITOR

Gives direct indications of magnitude and direction of frequency deviation of AM transmitter. Positive indication is provided for failure of either transmitter carrier or monitor crystal oscillator.
Frequency Range: 0.5-1.6 mc (specify crystal frequency).
Deviation Range: ±30 cps.
Primary Power: 105-125 or 210-250 v, 50/60 cps, 125 watts.
Size: 19" W, 15¾" H, 13" D (48.26 cm W, 40.01 cm H, 33.02 cm D).
Weight: 51 lbs. (23.4 kg).
Part No. 097 5948 —
No Part Number Spare set of tubes.
No Part Number FCC set of spare tubes.

SCHAFFER TRANSMITTER REMOTE CONTROL

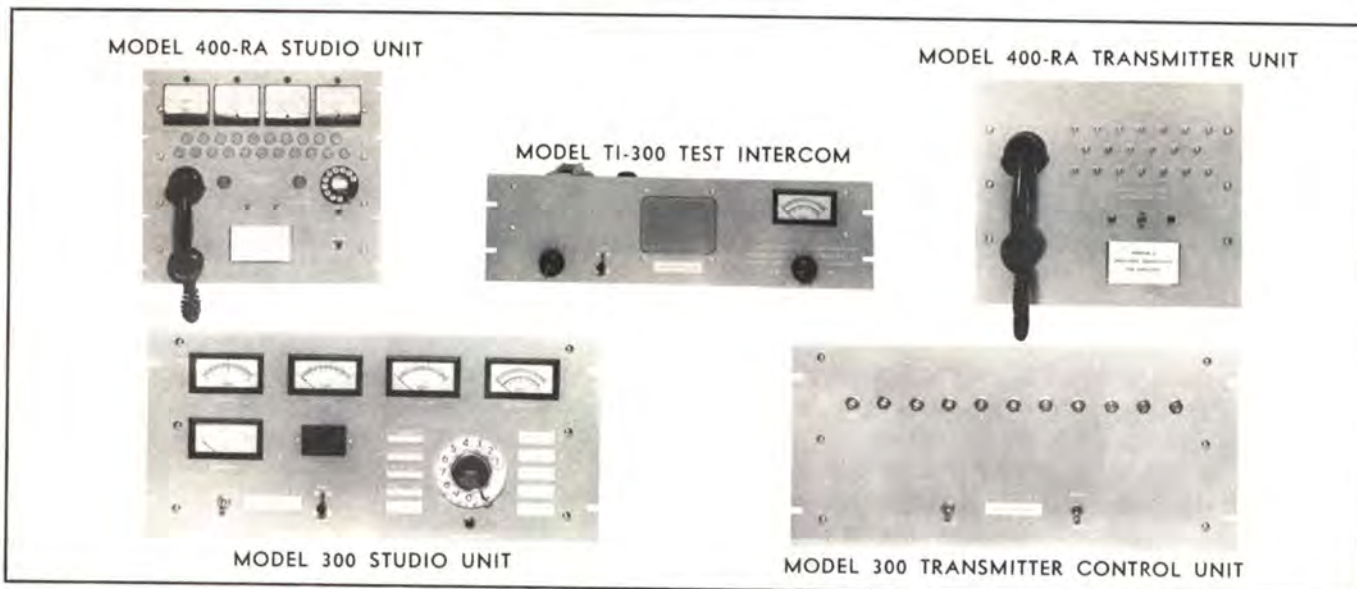

MODEL 400-RA STUDIO UNIT

An all DC Remote Control that operates on any two metallic lines (lowest tariff). Controls forty (40) different functions and meters twenty (20) different circuits and allows 2-way telephone conversations at all times. Four meters included.

Part No. 099 1518 000

MODEL 400-RA TRANSMITTER UNIT

Designed for location near the transmitter. Provides all calibration controls for the Studio Unit, as well as 110V AC to operate all accessory relays.

Part No. 099 1519 000

MODEL TI-300 TEST INTERCOM

This is a test intercom unit used with the Model 300 Remote Control System for 2-way communication, as well as being a test unit for checking the remote control operation. Two units are necessary for communication between studio and transmitter without additional telephone lines.

NPN

MODEL 300 STUDIO UNIT

A new all DC Remote Control system that operates on any two metallic lines with a resistance of up to 6000 ohms or more. Controls up to twenty (20) different functions and meters up to eleven (11) different circuits, including modulation and frequency. Five meters included. With a TI-300, two-way communication is available, as well as having a test unit at each end.

Part No. 597 0409 000

MODEL 300 TRANSMITTER CONTROL UNIT

Provides all calibration controls for the studio unit, as well as 48 V DC to operate all accessory relays.

Part No. 597 0410 000

REMOTE CONTROL ACCESSORIES

POR-1 PRIMARY OVERLOAD RELAY

Parallels present manual primary overload circuit breaker used in some transmitters, so that overload may be reset by Remote Control.

NPN

TOWER LIGHT CURRENT METERING UNIT TC-25

The TC-25 provides DC output to represent tower light current.

Part No. 099 1521 000

LATCHING RELAY UNIT LR-1-C

The LR-1-C is used to control circuits locally controlled by switches, such as filaments on-off and plates on-off.

Part No. 099 1520 000

MOTORIZED PLATE RHEOSTAT

For adjustment of plate power without affecting tuning.

MPR-2 For 250 or 500 watt transmitter. Part No. 099 1544 000

MPR-3 For 1000 watt transmitter. Part No. 099 1545 000

MPR-4 For over 1 Kilowatt transmitter. Part No. NPN

MOMENTARY RELAY UNIT MR-2-C

The MR-2-C is used to control circuits locally controlled by push-buttons, such as filaments on-off and plates on-off.

Part No. 097 6781 000

ANTENNA CURRENT METERING UNIT AC-100

The AC-100 provides DC output to represent antenna current.

Part No. 097 7581 000

PLATE CURRENT METERING UNIT PCK-10

The PCK-10 provides remote metering voltage to indicate plate current.

300 MA Part No. 099 1538 000

600 MA Part No. 099 1539 000

1200 MA Part No. 099 1540 000

2400 MA Part No. 097 6663 000

PLATE VOLTAGE METERING UNIT PV-10

The PV-10 provides remote metering voltage to indicate plate voltage for connection to any one mil metering circuit.

Part No. 097 664 000



COLLINS STL MICROWAVE SYSTEMS

As a part of its new Universal Microwave Group, Collins offers STL systems for the broadcast industry. These systems are part of a broad, flexible, transistorized product line.

Collins produces both remodulating and IF heterodyne systems operating in the 5.9 to 8.4 gc frequency range with output power of 1 and 5 watts and receiver bandwidths of 25 megacycles.

Collins' I-F heterodyne system features an improved signal-to-noise ratio, differential phase and differential gain performance over existing equipment.

COMMON CARRIER BAND 5925-6425 MC

MW-108A Video Application: 1 watt (+27 dbm) output Terminal or Remodulating Transmitter.

MW-109A-1 Video Application: 5 watt (+37 dbm) output Terminal or Remodulating Transmitter.

MW-109B Video Application: 5 watt (+37 dbm) output IF Heterodyn Transmitter, 100 mw Driver.

Note: Video Application is shown after type numbers to differentiate from Message Application.

TV — STL BAND 6875-7125 MC

MW-408A: 1 watt (+27 dbm) output Terminal or Remodulating Transmitter.

MW-409A-1: 5 watt (+37 dbm) output Terminal or Remodulating Transmitter.

MW-409B: 5 watt (+37 dbm) output IF Heterodyne Transmitter, 100 mw Driver.

GOVERNMENT BAND — 7125-8400 MC

MW-508A: Video Application: 1 watt (+27 dbm) output Terminal or Remodulating Transmitter.

MW-509A-1 Video Application: 5 watt (+37 dbm) output Terminal or Remodulating Transmitter.

MW-509B Video Application: 5 watt (+37 dbm) output IF Heterodyne Transmitter, 100 mw Driver.

For a low cost, high performance STL microwave system to fit your requirements, call or write Collins Radio Company, Dallas, Texas.

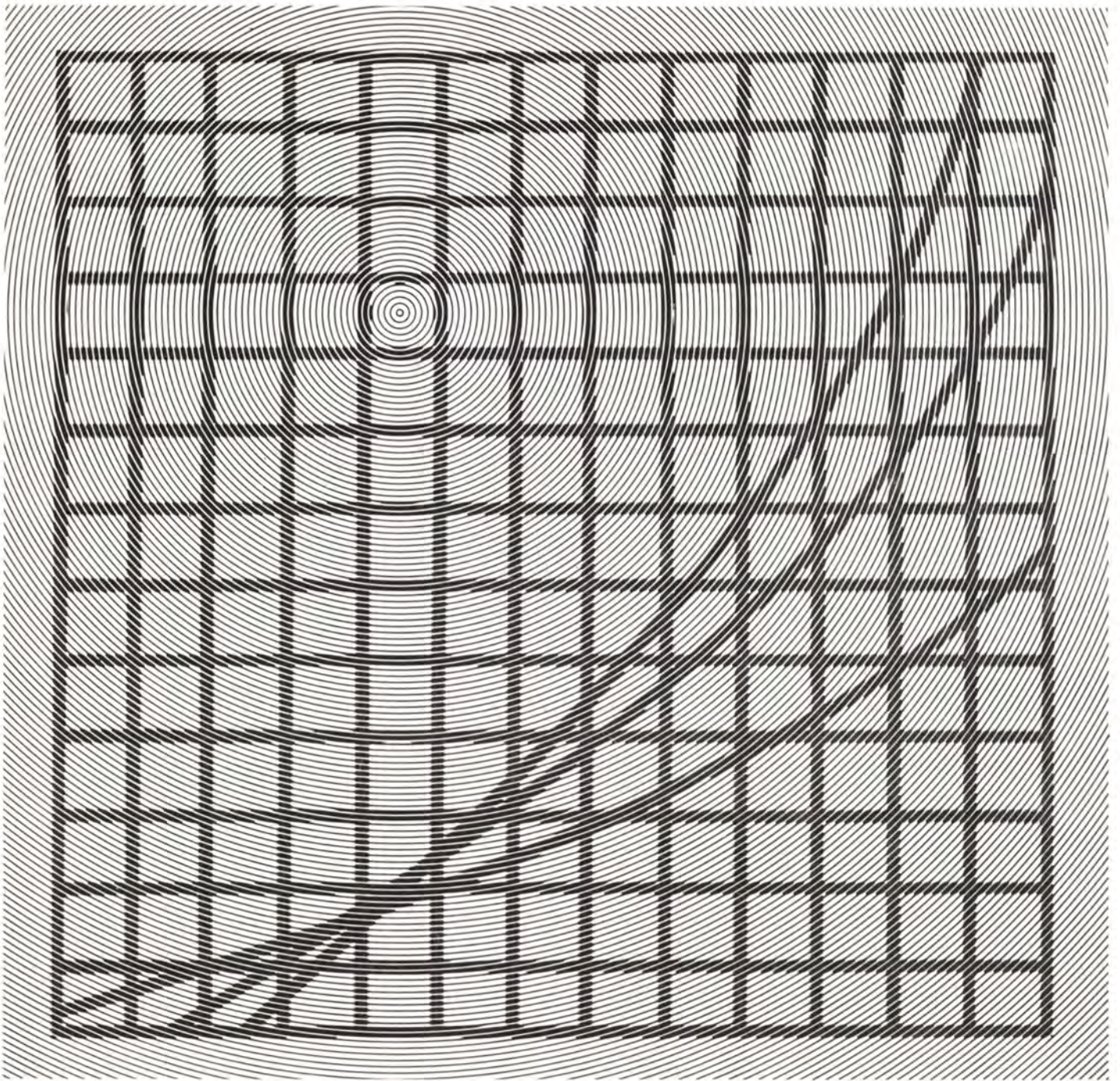

TABLES, CHARTS, GRAPHS

FINDING POWER AND VOLTAGE/CURRENT WHEN DECIBELS ARE KNOWN

Voltage Ratio	Power Ratio	-db+	Voltage Ratio	Power Ratio
1.0000	1.0000	0	1.000	1.000
.9886	.9772	.1	1.012	1.023
.9772	.9550	.2	1.023	1.047
.9661	.9333	.3	1.035	1.072
.9550	.9120	.4	1.047	1.096
.9441	.8913	.5	1.059	1.122
.9333	.8710	.6	1.072	1.148
.9226	.8511	.7	1.084	1.175
.9120	.8318	.8	1.096	1.202
.9016	.8128	.9	1.109	1.230
.8913	.7943	1.0	1.122	1.259
.8810	.7762	1.1	1.135	1.288
.8710	.7586	1.2	1.148	1.318
.8610	.7413	1.3	1.161	1.349
.8511	.7244	1.4	1.175	1.380
.8414	.7079	1.5	1.189	1.413
.8318	.6918	1.6	1.202	1.445
.8222	.6761	1.7	1.216	1.479
.8128	.6607	1.8	1.230	1.514
.8035	.6457	1.9	1.245	1.549
.7943	.6310	2.0	1.259	1.585
.7852	.6166	2.1	1.274	1.622
.7762	.6026	2.2	1.288	1.660
.7674	.5888	2.3	1.303	1.698
.7586	.5754	2.4	1.318	1.738
.7499	.5623	2.5	1.334	1.778
.7413	.5495	2.6	1.349	1.820
.7328	.5370	2.7	1.365	1.862
.7244	.5248	2.8	1.380	1.905
.7161	.5129	2.9	1.396	1.950
.7079	.5012	3.0	1.413	1.995
.6998	.4898	3.1	1.429	2.042
.6918	.4786	3.2	1.445	2.089
.6839	.4677	3.3	1.462	2.138
.6761	.4571	3.4	1.479	2.188
.6683	.4467	3.5	1.496	2.239
.6607	.4365	3.6	1.514	2.291
.6531	.4266	3.7	1.531	2.344
.6457	.4169	3.8	1.549	2.399
.6383	.4074	3.9	1.567	2.455
.6310	.3981	4.0	1.585	2.512
.6237	.3890	4.1	1.603	2.570
.6166	.3802	4.2	1.622	2.630
.6095	.3715	4.3	1.641	2.692
.6026	.3631	4.4	1.660	2.754
.5957	.3548	4.5	1.679	2.818
.5888	.3467	4.6	1.698	2.884
.5821	.3388	4.7	1.718	2.951
.5754	.3311	4.8	1.738	3.020
.5689	.3236	4.9	1.758	3.090

Voltage Ratio	Power Ratio	-db+	Voltage Ratio	Power Ratio
.5623	.3162	5.0	1.778	3.162
.5559	.3090	5.1	1.799	3.236
.5495	.3020	5.2	1.820	3.311
.5433	.2951	5.3	1.841	3.388
.5370	.2884	5.4	1.862	3.467
.5309	.2818	5.5	1.884	3.548
.5248	.2754	5.6	1.905	3.631
.5188	.2692	5.7	1.928	3.715
.5129	.2630	5.8	1.950	3.802
.5070	.2570	5.9	1.972	3.890
.5012	.2512	6.0	1.995	3.981
.4955	.2455	6.1	2.018	4.074
.4898	.2399	6.2	2.042	4.169
.4842	.2344	6.3	2.065	4.266
.4786	.2291	6.4	2.089	4.365
.4732	.2239	6.5	2.113	4.467
.4677	.2188	6.6	2.138	4.571
.4624	.2138	6.7	2.163	4.677
.4571	.2089	6.8	2.188	4.786
.4519	.2042	6.9	2.213	4.898
.4467	.1995	7.0	2.239	5.012
.4416	.1950	7.1	2.265	5.129
.4365	.1905	7.2	2.291	5.248
.4315	.1862	7.3	2.317	5.370
.4266	.1820	7.4	2.344	5.495
.4217	.1778	7.5	2.371	5.623
.4169	.1738	7.6	2.399	5.754
.4121	.1698	7.7	2.427	5.888
.4074	.1660	7.8	2.455	6.026
.4027	.1622	7.9	2.483	6.166
.3981	.1585	8.0	2.512	6.310
.3936	.1549	8.1	2.541	6.457
.3890	.1514	8.2	2.570	6.607
.3846	.1479	8.3	2.600	6.761
.3802	.1445	8.4	2.630	6.918
.3758	.1413	8.5	2.661	7.079
.3715	.1380	8.6	2.692	7.244
.3673	.1349	8.7	2.723	7.413
.3631	.1318	8.8	2.754	7.586
.3589	.1288	8.9	2.786	7.762
.3548	.1259	9.0	2.818	7.943
.3508	.1230	9.1	2.851	8.128
.3467	.1202	9.2	2.884	8.318
.3428	.1175	9.3	2.917	8.511
.3388	.1148	9.4	2.951	8.710
.3350	.1122	9.5	2.985	8.913
.3311	.1096	9.6	3.020	9.120
.3273	.1072	9.7	3.055	9.333
.3236	.1047	9.8	3.090	9.550
.3199	.1023	9.9	3.126	9.772

FINDING POWER AND VOLTAGE/CURRENT WHEN DECIBELS ARE KNOWN (Continued)

Voltage Ratio	Power Ratio	-db+	Voltage Ratio	Power Ratio	Voltage Ratio	Power Ratio	-db+	Voltage Ratio	Power Ratio
.3612	.1000	10.0	3.162	10.000	.1778	.03162	15.0	5.623	31.62
.3126	.09772	10.1	3.199	10.23	.1758	.03090	15.1	5.689	32.36
.3090	.09550	10.2	3.236	10.47	.1738	.03020	15.2	5.754	33.11
.3055	.09333	10.3	3.273	10.72	.1718	.02951	15.3	5.821	33.88
.3020	.09120	10.4	3.311	10.96	.1698	.02884	15.4	5.888	34.67
.2985	.08913	10.5	3.350	11.22	.1679	.02818	15.5	5.957	35.48
.2951	.08710	10.6	3.388	11.48	.1660	.02754	15.6	6.026	36.31
.2917	.08511	10.7	3.428	11.75	.1641	.02692	15.7	6.095	37.15
.2884	.08318	10.8	3.467	12.02	.1622	.02630	15.8	6.166	38.02
.2851	.08128	10.9	3.508	12.30	.1603	.02570	15.9	6.237	38.90
.2818	.07943	11.0	3.548	12.59	.1585	.02512	16.0	6.310	39.81
.2786	.07762	11.1	3.589	12.88	.1567	.02455	16.1	6.383	40.74
.2754	.07586	11.2	3.631	13.18	.1549	.02399	16.2	6.457	41.69
.2723	.07413	11.3	3.673	13.49	.1531	.02344	16.3	6.531	42.66
.2692	.07244	11.4	3.715	13.80	.1514	.02291	16.4	6.607	43.65
.2661	.07079	11.5	3.758	14.13	.1496	.02239	16.5	6.683	44.67
.2630	.06918	11.6	3.802	14.45	.1479	.02188	16.6	6.761	45.71
.2600	.06761	11.7	3.846	14.79	.1462	.02138	16.7	6.839	46.77
.2570	.06607	11.8	3.890	15.14	.1445	.02089	16.8	6.918	47.86
.2541	.06457	11.9	3.936	15.49	.1429	.02042	16.9	6.998	48.98
.2512	.06310	12.0	3.981	15.85	.1413	.01995	17.0	7.079	50.12
.2483	.06166	12.1	4.027	16.22	.1396	.01950	17.1	7.161	51.29
.2455	.06026	12.2	4.074	16.60	.1380	.01905	17.2	7.244	52.48
.2427	.05888	12.3	4.121	16.98	.1365	.01862	17.3	7.328	53.70
.2399	.05754	12.4	4.169	17.38	.1349	.01820	17.4	7.413	54.95
.2371	.05623	12.5	4.217	17.78	.1334	.01778	17.5	7.499	56.23
.2344	.05495	12.6	4.266	18.20	.1318	.01738	17.6	7.586	57.54
.2317	.05370	12.7	4.315	18.62	.1303	.01698	17.7	7.674	58.88
.2291	.05248	12.8	4.365	19.05	.1288	.01660	17.8	7.762	60.26
.2265	.05129	12.9	4.416	19.50	.1274	.01622	17.9	7.852	61.66
.2239	.05012	13.0	4.467	19.95	.1259	.01585	18.0	7.943	63.10
.2213	.04898	13.1	4.519	20.42	.1245	.01549	18.1	8.035	64.57
.2188	.04786	13.2	4.571	20.89	.1230	.01514	18.2	8.128	66.07
.2163	.04677	13.3	4.624	21.38	.1216	.01479	18.3	8.222	67.61
.2138	.04571	13.4	4.677	21.88	.1202	.01445	18.4	8.318	69.18
.2113	.04467	13.5	4.732	22.39	.1189	.01413	18.5	8.414	70.79
.2089	.04365	13.6	4.786	22.91	.1175	.01380	18.6	8.511	72.44
.2065	.04266	13.7	4.842	23.44	.1161	.01349	18.7	8.610	74.13
.2042	.04169	13.8	4.898	23.99	.1148	.01318	18.8	8.710	75.86
.2018	.04074	13.9	4.955	24.55	.1135	.01288	18.9	8.811	77.62
.1995	.03981	14.0	5.012	25.12	.1122	.01259	19.0	8.913	79.43
.1972	.03890	14.1	5.070	25.70	.1109	.01230	19.1	9.016	81.28
.1950	.03802	14.2	5.129	26.30	.1096	.01202	19.2	9.120	83.18
.1928	.03715	14.3	5.188	26.92	.1084	.01175	19.3	9.226	85.11
.1905	.03631	14.4	5.248	27.54	.1072	.01148	19.4	9.333	87.10
.1884	.03548	14.5	5.309	28.18	.1059	.01122	19.5	9.441	89.13
.1862	.03467	14.6	5.370	28.84	.1047	.01096	19.6	9.550	91.20
.1841	.03388	14.7	5.433	29.51	.1035	.01072	19.7	9.661	93.33
.1820	.03311	14.8	5.495	30.20	.1023	.01047	19.8	9.772	95.50
.1799	.03236	14.9	5.559	30.90	.1012	.01023	19.9	9.886	97.72
					.1000	.01000	20.0	10.000	100.00

FINDING DECIBELS WHEN VOLTAGE/CURRENT RATIO IS KNOWN

Voltage Ratio	.00	.01	.02	.03	.04	.05	.06	.07	.08	.09
1.0	.000	.086	.172	.257	.341	.424	.506	.588	.668	.749
1.1	.828	.906	.984	1.062	1.138	1.214	1.289	1.364	1.438	1.511
1.2	1.584	1.656	1.727	1.798	1.868	1.938	2.007	2.076	2.144	2.212
1.3	2.279	2.345	2.411	2.477	2.542	2.607	2.671	2.734	2.798	2.860
1.4	2.923	2.984	3.046	3.107	3.167	3.227	3.287	3.346	3.405	3.464
1.5	3.522	3.580	3.637	3.694	3.750	3.807	3.862	3.918	3.973	4.028
1.6	4.082	4.137	4.190	4.244	4.297	4.350	4.402	4.454	4.506	4.558
1.7	4.609	4.660	4.711	4.761	4.811	4.861	4.910	4.959	5.008	5.057
1.8	5.105	5.154	5.201	5.249	5.296	5.343	5.390	5.437	5.483	5.529
1.9	5.575	5.621	5.666	5.711	5.756	5.801	5.845	5.889	5.933	5.977
2.0	6.021	6.064	6.107	6.150	6.193	6.235	6.277	6.319	6.361	6.403
2.1	6.444	6.486	6.527	6.568	6.608	6.649	6.689	6.729	6.769	6.809
2.2	6.848	6.888	6.927	6.966	7.008	7.044	7.082	7.121	7.159	7.197
2.3	7.235	7.272	7.310	7.347	7.384	7.421	7.458	7.495	7.532	7.568
2.4	7.604	7.640	7.676	7.712	7.748	7.783	7.819	7.854	7.889	7.924
2.5	7.959	7.993	8.028	8.062	8.097	8.131	8.165	8.199	8.232	8.266
2.6	8.299	8.333	8.366	8.399	8.432	8.465	8.498	8.530	8.563	8.595
2.7	8.627	8.659	8.691	8.723	8.755	8.787	8.818	8.850	8.881	8.912
2.8	8.943	8.974	9.005	9.036	9.066	9.097	9.127	9.158	9.188	9.218
2.9	9.248	9.278	9.308	9.337	9.367	9.396	9.426	9.455	9.484	9.513
3.0	9.542	9.571	9.600	9.629	9.657	9.686	9.714	9.743	9.771	9.799
3.1	9.827	9.855	9.883	9.911	9.939	9.966	9.994	10.021	10.049	10.076
3.2	10.103	10.130	10.157	10.184	10.211	10.238	10.264	10.291	10.317	10.344
3.3	10.370	10.397	10.423	10.449	10.475	10.501	10.527	10.553	10.578	10.604
3.4	10.630	10.655	10.681	10.706	10.731	10.756	10.782	10.807	10.832	10.857
3.5	10.881	10.906	10.931	10.955	10.980	11.005	11.029	11.053	11.078	11.102
3.6	11.126	11.150	11.174	11.198	11.222	11.246	11.270	11.293	11.317	11.341
3.7	11.364	11.387	11.411	11.434	11.457	11.481	11.504	11.527	11.550	11.573
3.8	11.596	11.618	11.641	11.664	11.687	11.709	11.732	11.754	11.777	11.799
3.9	11.821	11.844	11.866	11.888	11.910	11.932	11.954	11.976	11.998	12.019
4.0	12.041	12.063	12.085	12.106	12.128	12.149	12.171	12.192	12.213	12.234
4.1	12.256	12.277	12.298	12.319	12.340	12.361	12.382	12.403	12.424	12.444
4.2	12.465	12.486	12.506	12.527	12.547	12.568	12.588	12.609	12.629	12.649
4.3	12.669	12.690	12.710	12.730	12.750	12.770	12.790	12.810	12.829	12.849
4.4	12.869	12.889	12.908	12.928	12.948	12.967	12.987	13.006	13.026	13.045
4.5	13.064	13.084	13.103	13.122	13.141	13.160	13.179	13.198	13.217	13.236
4.6	13.255	13.274	13.293	13.312	13.330	13.349	13.368	13.386	13.405	13.423
4.7	13.442	13.460	13.479	13.497	13.516	13.534	13.552	13.570	13.589	13.607
4.8	13.625	13.643	13.661	13.679	13.697	13.715	13.733	13.751	13.768	13.786
4.9	13.804	13.822	13.839	13.857	13.875	13.892	13.910	13.927	13.945	13.962
5.0	13.979	13.997	14.014	14.031	14.049	14.066	14.083	14.100	14.117	14.134
5.1	14.151	14.168	14.185	14.202	14.219	14.236	14.253	14.270	14.287	14.303
5.2	14.320	14.337	14.353	14.370	14.387	14.403	14.420	14.436	14.453	14.469
5.3	14.486	14.502	14.518	14.535	14.551	14.567	14.583	14.599	14.616	14.632
5.4	14.648	14.664	14.680	14.696	14.712	14.728	14.744	14.760	14.776	14.791
5.5	14.807	14.823	14.839	14.855	14.870	14.886	14.902	14.917	14.933	14.948
5.6	14.964	14.979	14.995	15.010	15.026	15.041	15.056	15.072	15.087	15.102
5.7	15.117	15.133	15.148	15.163	15.178	15.193	15.208	15.224	15.239	15.254
5.8	15.269	15.284	15.298	15.313	15.328	15.343	15.358	15.373	15.388	15.402
5.9	15.417	15.432	15.446	15.461	15.476	15.490	15.505	15.519	15.534	15.549
6.0	15.563	15.577	15.592	15.606	15.621	15.635	15.649	15.664	15.678	15.692
6.1	15.707	15.721	15.735	15.749	15.763	15.778	15.792	15.806	15.820	15.834
6.2	15.848	15.862	15.876	15.890	15.904	15.918	15.931	15.945	15.959	15.973
6.3	15.987	16.001	16.014	16.028	16.042	16.055	16.069	16.083	16.096	16.110
6.4	16.124	16.137	16.151	16.164	16.178	16.191	16.205	16.218	16.232	16.245

FINDING DECIBELS WHEN VOLTAGE/CURRENT RATIO IS KNOWN (Continued)

Voltage Ratio	.00	.01	.02	.03	.04	.05	.06	.07	.08	.09
6.5	16.258	16.272	16.285	16.298	16.312	16.325	16.338	16.351	16.365	16.378
6.6	16.391	16.404	16.417	16.430	16.443	16.456	16.469	16.483	16.496	16.509
6.7	16.521	16.534	16.547	16.560	16.573	16.586	16.599	16.612	16.625	16.637
6.8	16.650	16.663	16.676	16.688	16.701	16.714	16.726	16.739	16.752	16.764
6.9	16.777	16.790	16.802	16.815	16.827	16.840	16.852	16.865	16.877	16.890
7.0	16.902	16.914	16.927	16.939	16.951	16.964	16.976	16.988	17.001	17.013
7.1	17.025	17.037	17.050	17.062	17.074	17.086	17.098	17.110	17.122	17.135
7.2	17.147	17.159	17.171	17.183	17.195	17.207	17.219	17.231	17.243	17.255
7.3	17.266	17.278	17.290	17.302	17.314	17.326	17.338	17.349	17.361	17.373
7.4	17.385	17.396	17.408	17.420	17.431	17.443	17.455	17.466	17.478	17.490
7.5	17.501	17.513	17.524	17.536	17.547	17.559	17.570	17.582	17.593	17.605
7.6	17.616	17.628	17.639	17.650	17.662	17.673	17.685	17.696	17.707	17.719
7.7	17.730	17.741	17.752	17.764	17.775	17.786	17.797	17.808	17.820	17.831
7.8	17.842	17.853	17.864	17.875	17.886	17.897	17.908	17.919	17.931	17.942
7.9	17.953	17.964	17.975	17.985	17.996	18.007	18.018	18.029	18.040	18.051
8.0	18.062	18.073	18.083	18.094	18.105	18.116	18.127	18.137	18.148	18.159
8.1	18.170	18.180	18.191	18.202	18.212	18.223	18.234	18.244	18.255	18.266
8.2	18.276	18.287	18.297	18.308	18.319	18.329	18.340	18.350	18.361	18.371
8.3	18.382	18.392	18.402	18.413	18.423	18.434	18.444	18.455	18.465	18.475
8.4	18.486	18.496	18.506	18.517	18.527	18.537	18.547	18.558	18.568	18.578
8.5	18.588	18.599	18.609	18.619	18.629	18.639	18.649	18.660	18.670	18.680
8.6	18.690	18.700	18.710	18.720	18.730	18.740	18.750	18.760	18.770	18.780
8.7	18.790	18.800	18.810	18.820	18.830	18.840	18.850	18.860	18.870	18.880
8.8	18.890	18.900	18.909	18.919	18.929	18.939	18.949	18.958	18.968	18.978
8.9	18.988	18.998	19.007	19.017	19.027	19.036	19.046	19.056	19.066	19.075
9.0	19.085	19.094	19.104	19.114	19.123	19.133	19.143	19.152	19.162	19.171
9.1	19.181	19.190	19.200	19.209	19.219	19.228	19.238	19.247	19.257	19.226
9.2	19.276	19.285	19.295	19.304	19.313	19.323	19.332	19.342	19.351	19.360
9.3	19.370	19.379	19.388	19.398	19.407	19.416	19.426	19.435	19.444	19.453
9.4	19.463	19.472	19.481	19.490	19.499	19.509	19.518	19.527	19.536	19.545
9.5	19.554	19.564	19.573	19.582	19.591	19.600	19.609	19.618	19.627	19.636
9.6	19.645	19.654	19.664	19.673	19.682	19.691	19.700	19.709	19.718	19.726
9.7	19.735	19.744	19.753	19.762	19.771	19.780	19.789	19.798	19.807	19.816
9.8	19.825	19.833	19.842	19.851	19.860	19.869	19.878	19.886	19.895	19.904
9.9	19.913	19.921	19.930	19.939	19.948	19.956	19.965	19.974	19.983	19.991

Voltage Ratio	0	1	2	3	4	5	6	7	8	9
10	20.000	20.828	21.584	22.279	22.923	23.522	24.082	24.609	25.105	25.575
20	26.021	26.444	26.848	27.235	27.604	27.959	28.299	28.627	28.943	29.248
30	29.542	29.827	30.103	30.370	30.630	30.881	31.126	31.364	31.596	31.821
40	32.041	32.256	32.465	32.669	32.869	33.064	33.255	33.442	33.625	33.804
50	33.979	34.151	34.320	34.486	34.648	34.807	34.964	35.117	35.269	35.417
60	35.563	35.707	35.848	35.987	36.124	36.258	36.391	36.521	36.650	36.777
70	36.902	37.025	37.147	37.266	37.385	37.501	37.616	37.730	37.842	37.953
80	38.062	38.170	38.276	38.382	38.486	38.588	38.690	38.790	38.890	38.988
90	39.085	39.181	39.276	39.370	39.463	39.554	39.645	39.735	39.825	39.913
100	40.000	—	—	—	—	—	—	—	—	—

Distance in Miles From an FM Transmitter to
Its 54 dbu (0.5 mv/m) Contour For Various Heights and Powers

AHAAT in Ft.	Power in dbk																				
	-20	-18	-16	-14	-12	-10	-8	-6	-4	-2	0	2	4	6	8	10	12	14	16	18	20
3400	20	23	26.5	30	34	38	42	47.5	51.5	55	60	65	69.5	73	78	82	87	91.5	95	100	113.5
3200	19	22	25	29	32.5	37	40.5	45	50	53.5	58.5	63	67	71	75	80	85	90	93	97	100.5
3000	18.5	21.5	24.5	28	31.5	35	40	43	48	52	56.5	60.5	65	69.5	73	77.5	82	86.5	91.5	95	98.5
2800	18	20.5	23	27	30	33.5	38	42	45.5	50	54.5	58.5	63	67	71	75	80	84	89	93	96
2600	17.5	20	22	25.5	29	32	36	40	44.5	48.5	52	56	60	65	69	73	77	81.5	85.5	90	94
2400	17	19	21.5	24.5	28	31	35	38.5	42	46	50.5	54.5	58.5	62	67	70.5	75	78.7	83	88	92
2200	16	18.2	20	23	26.5	29	32.5	36.5	40	44.5	48	52	55.5	60	65	68	72	76.5	80	85	90
2000	15	17.4	19	22	25	28	31	35	38	42	45.5	50	53	57	61.5	65	69.5	73.7	78	82	86
1900	15	17	18.5	21.5	24.5	27	30	33.5	37.5	40.5	45	48.5	52	55.5	60	64	68	72	76	80	85
1800	14	16	18	20.5	23	26.5	29	32.5	36	40	43	47.5	51	55	58.5	62.5	66	70	75	79	83
1700	13.5	15.5	17.5	20	22.5	25	28	31.5	35	38	42	45.5	50	53	57	60.5	65	69	71.5	77	81
1600	13	15	17	19	21.5	24.5	27	30	33	36.5	40.5	44	48	52	55.5	60	63	67	71	75	80
1500	12.5	14.6	16.5	18.5	21	23.5	26.5	28.5	32	35.5	39.5	43	46.5	50	54.5	58	61.5	65	69.5	73	78
1400	12	14	16	18	20	22	25	28	30.5	34.5	38	41.5	45	48.5	52.5	56	60	63	67	71.5	75
1300	11.5	13.4	15.5	17	19	21.5	23.5	27	30	32.5	36	40	43	47	50.5	55	58	61.5	65	70	73.5
1200	11	13	14.5	16.5	18.5	20.5	23	25.5	28	31	35	38	41.7	45	48.5	52.5	56	60	63	67	71.5
1100	10	12	13.5	15.5	17.5	19.5	21.5	24.5	26.5	30	33	36.5	40	43	47	50.5	54.5	58	61.5	65	70
1000	9.1	11.5	13	15	17	18.5	20.5	23	25.5	28	31.2	34.5	38	41	45	48	52	56	58.5	63	68
900	8.7	10.5	12	14	16	18	19.5	21.5	24.5	27	29.6	32.5	35.5	38.5	42.5	46	50	54	57	60.5	65
800	8.2	9.2	11.5	13	15	16.5	18	20	22	25	28	30.5	33.5	37	40	43	47.5	52	55	58.5	63.5
700	7.7	8.7	10.5	12	13.5	15.5	17	18.5	21	23	26	28.5	32	35	38	41	45	49	53	56.5	63
600	7.2	8	9	11	12	14	15.5	17.5	19	21.5	24	26.5	28.7	32	35	38	42	45.5	50	55	60
500	6.5	7.3	8.2	9	11	12.5	14	16	17.5	19	22	24	27	29	32.5	35.5	38.5	43	47	52	57
400	5.8	6.6	7.3	8.3	8.5	11	12.5	14	16	17.5	19	22	24.5	27	29.5	32	35.5	40	43.5	49.5	55
300	5	5.7	6.5	7.2	8	8.7	10.5	12	13.5	15	17	18.5	21	23.5	26.5	28.5	32	35.5	40	45.4	52
200	4	4.6	5.2	5.7	6.5	7.3	8.2	9	11	12	13.7	15.5	17.5	19	22	24.5	28	31.5	35	42	48
100	2.8	3.2	3.7	4.1	4.6	5.2	5.8	6.6	7.4	8.2	9	10.7	12.5	14	16	18.2	21.5	25	30	35.5	45

Distance in Miles From an FM Transmitter to Its 60 dbu (1 Mv/m) Contour For Various Heights and Powers

Power in dbk

AHAAT

in Ft.	-20	-18	-16	-14	-12	-10	-8	-6	-4	-2	0	2	4	6	8	10	12	14	16	18	20	
3400	11	13	15	17.5	20	22.5	27	30	34	37	40.5	45	49	52	57	60	64	65	65	65	65	65
3200	11	12.2	14.5	16.5	19.5	22	25	28.5	32	35	39	42.5	47	50.5	55	59	62	64	65	65	65	65
3000	10.5	12	14	16	19	21.5	24.5	28	31	34	38	41	45	49.5	53	57	60	64	65	65	65	65
2800	10	11.8	13.5	15.7	18	20.5	24	26.5	30	33	36	40	44	48	51	55	59	62	64	65	65	65
2600	9.7	11.5	13	15	17	20	22.5	25.5	29	32	35	39	42	46	49.5	53	58	60	63	64	65	65
2400	9.4	11	12.8	14	16	19	21.5	24.5	28	30.5	34	37	40	44	47.5	51	55	59	61	64	65	65
2200	9.2	10.8	12	13.5	15.5	18	20.5	23.5	26	29	32	35	39	42	45.5	49	52	56.5	59.5	62	65	65
2000	9	10.2	11.7	13.1	15	17	20	22	25	28	30	33.5	37	40	44	46.5	50.5	54	57.5	60.5	64	64
1900	8.7	10	11.2	12.7	14.5	16.5	19	21.5	24.5	27	29.5	33	35.5	39	43.5	45.5	49.5	52.5	55.5	59.5	62	62
1800	8.5	9.7	11	12.6	14	16	18	20.5	23.5	25.5	29	31.5	35	38.5	43	44.5	48.5	51.5	55	59	61	61
1700	8.3	9.2	10.5	11.6	13.8	15.5	17.3	20	22.5	25	28	30	33	37	40	43	46.5	50	53	57.5	60	60
1600	8.1	9	10.3	11.5	13.2	15	17.1	19.2	21.5	24	26.5	29.5	32.5	35.5	39	42	45	49	51.5	55	58	58
1500	8	9	10	11.4	13	14.9	16.9	18.6	21	23	26	28.5	31.5	35	38	40.5	44	47	50.1	54	57	57
1400	7.5	8.6	9.7	11.2	12.5	14	16.2	18	20	22	25	27.5	30	33	36	40	43	46	48.5	52	55	55
1300	7.3	8.2	9.3	10.5	12	13.8	15.5	17.5	19	21.5	24	26.5	29	32.5	35	39	41.5	45	47.5	51	54	54
1200	7	7.8	9	10	11.5	13	15	17	18	21	23	25.5	28	31	34	37.5	40	44	46	49	52	52
1100	6.8	7.6	8.5	9.5	11	12.5	14.5	16	17.1	20	22	24.5	26.5	29.5	32	35	38	41	44.5	47	50	50
1000	6.4	7.2	8	9	10.2	12	14	15.6	17	19	21	23	25.5	28	31	34	36.5	40	43	45.5	49	49
900	6.2	6.8	7.8	8.8	9.7	11.2	13	14.5	16.4	18	20	21	24.5	26	29	32	35	38	40.5	44	47	47
800	5.8	6.6	7.3	8.2	9.2	10.3	12	13.5	15.2	17	18.5	20.5	23	25	27.5	30	33	36	39	41.5	45	45
700	5.4	6.2	7	7.8	8.6	9.7	10.5	13	14	16	17	19.2	21	24	26	28.5	31	33	36	39	41.5	42
600	5	5.7	6.5	7.1	8	9	9.8	11.8	12.3	14.5	16	18	19.7	21.5	24	26	29	32	35	36.5	40	40
500	4.6	5	5.8	6.6	7.3	8.2	9	10	12	13.2	14.5	16.1	17.9	20	22	24.5	27	29.5	31.5	35	37	37
450	4.2	4.8	5.5	6.2	7.0	7.8	8.6	9.6	10.5	12.5	14.0	15.2	17.0	19.0	20.5	23.0	25.4	28	30	33	36	36
400	4	4.6	5.1	5.9	6.6	7.4	8.2	9	10	11.8	12.5	14.5	16	17.8	19.8	21.5	24.5	26.5	29	31.5	35	35
350	3.8	4.2	4.8	5.3	6.1	7.0	7.8	8.6	9.5	10.3	11.0	14.0	15	16.8	18.5	20.2	23	25	27.5	30	33	33
300	3.6	4	4.5	5	5.7	6.3	7.2	8	8.8	10	10.5	12.6	14	15.6	17	19	21	23	25.5	28	30	30
250	3.2	3.7	4.0	4.6	5.1	5.9	6.7	7.3	8.0	8.9	9.9	10.6	12.5	14.0	15.8	17.8	19	21.5	24	26	28	28
200	2.9	3.3	3.7	4.1	4.7	5.1	5.9	6.6	7.4	8.1	9	10	11.3	12.5	14	15.5	17.5	19.5	21.5	24	26	26
150	2.5	2.8	3.2	3.6	4.0	4.5	5.0	5.7	6.4	7.1	7.9	8.8	9.7	10.8	12	14.0	15.2	17.0	19	21	24	24
100	2	2.3	2.7	2.9	3.2	3.8	4.1	4.7	5.2	5.9	6.5	7.4	8.3	9	10	11.3	12.9	14.5	16.2	18.1	20	20

Distance in Miles From an FM Transmitter to Its 80 dbu (10 mv/m) Contour For Various Heights and Powers

AHAAT in Ft.	Power in dbk																				
	-20	-18	-16	-14	-12	-10	-8	-6	-4	-2	0	2	4	6	8	10	12	14	16	18	20
3400	1.3	1.8	2.1	2.6	3.2	4.0	4.8	6.0	7.3	9	12.5	15	18	20	23	26.5	30	34	38	42	46.5
3200	1.3	1.8	2.1	2.6	3.2	4.0	4.8	6.0	7.3	8.8	12	15	17	19	22	25	29	32.5	36.5	40.5	45
3000	1.3	1.8	2.1	2.6	3.2	4.0	4.8	6.0	7.1	8.5	11.5	14.5	17	18.5	21.5	24.5	28	31.5	35	40	43
2800	1.3	1.8	2.1	2.5	3.2	4.0	4.8	5.9	7.1	8.4	11.3	14	16	18	20	23	26.5	30	34	38	41.5
2600	1.3	1.8	2.1	2.5	3.2	4.0	4.7	5.8	7.0	8.1	11	13	15.5	17.5	19.6	22	25.5	29	32	35.5	40
2400	1.3	1.8	2.1	2.5	3.2	3.9	4.7	5.7	7.0	8.1	10.5	12.5	15	17	19	21.5	24.5	27.5	30.5	35	38.5
2200	1.3	1.8	2.1	2.5	3.2	3.8	4.7	5.6	6.8	8	10	12	14.5	16.5	18	20	23	26.5	29.5	32.5	36.5
2000	1.3	1.8	2.0	2.5	3.1	3.8	4.6	5.4	6.7	7.8	9	11.5	13.5	15	17.5	19.5	21.5	25	28	31	35
1900	1.3	1.8	2.0	2.5	3.0	3.7	4.6	5.3	6.6	7.7	9	11	13	14.8	17	19	21	24.5	27	30	34
1800	1.3	1.8	2.0	2.5	3.0	3.7	4.5	5.3	6.3	7.6	8.7	10.5	12.5	14.5	16.5	18.5	20.5	23	26	29	32.5
1700	1.3	1.8	2.0	2.4	2.9	3.6	4.4	5.2	6.1	7.3	8.4	10	12	14	15.5	18	20	22	25	28	31
1600	1.2	1.7	2.0	2.3	2.9	3.6	4.3	5.1	6	7.0	8.1	9.2	11.8	13.5	15	17.5	19	21.5	24.5	27	30
1500	1.2	1.7	2.0	2.3	2.8	3.6	4.2	5.0	5.9	7.0	8.0	9.0	11	13	14.5	17	18.5	20.5	23	26	29
1400	1.2	1.7	1.9	2.3	2.8	3.5	4.2	5.0	5.7	6.7	7.7	8.7	10.5	12	14	16	18	20	22	25	28
1300	1.2	1.7	1.9	2.2	2.7	3.4	4.1	4.8	5.6	6.4	7.4	8.3	10	11.5	13	15	17	19	21.5	24	26.5
1200	1.2	1.7	1.8	2.2	2.7	3.3	4.0	4.7	5.4	6.2	7.1	8	9.2	11	12.5	14.5	16.5	18	20.5	23	25.5
1100	1.2	1.7	1.8	2.2	2.7	3.2	3.9	4.6	5.2	6	6.8	7.8	8.7	10.2	11.5	14	15.5	17.5	19.5	22	24.5
1000	1.2	1.6	1.8	2.2	2.6	3.1	3.8	4.4	5	5.8	6.4	7.2	8.2	9.2	11	13	15	17	18.5	20.5	23
900	1.2	1.6	1.7	2.1	2.6	3	3.7	4.2	4.8	5.6	6.2	7.0	7.8	8.8	10.5	12	14	16	18	19	22
800	1.2	1.5	1.7	2.1	2.5	2.9	3.4	3.9	4.6	5.1	6.0	6.7	7.4	8.3	9.3	11.5	13	15	16.5	18	20
700	1.2	1.5	1.7	2.0	2.4	2.8	3.2	3.7	4.2	4.8	5.5	6.3	7.0	7.8	8.8	10	12	13.5	15.5	17	18.5
600	1.2	1.4	1.7	1.9	2.3	2.7	3.0	3.4	3.8	4.5	5.0	5.8	6.5	7.2	8	9.0	10.5	12.5	14	15.5	17.5
500	1.1	1.4	1.6	1.8	2.1	2.5	2.8	3.2	3.6	4	4.6	5.2	6	6.7	7.5	8.2	9.2	11	12.5	14.5	15.5
400	1.0	1.3	1.5	1.7	2.0	2.2	2.6	2.8	3.2	3.7	4.1	4.7	5.2	6.0	6.7	7.5	8.2	9.1	11	12.5	14.5
300	0.9	1.2	1.3	1.5	1.8	1.9	2.2	2.6	2.8	3.2	3.6	4	4.5	5.0	5.8	6.2	7.2	7.8	8.9	10.5	12
200	0.8	1.0	1.2	1.3	1.5	1.7	1.8	2	2.3	2.6	3.0	3.3	3.8	4.2	4.7	5.2	6.0	6.7	7.5	8.2	9.0
100	0.5	0.6	0.8	0.9	1.0	1.2	1.3	1.5	1.7	1.9	2.0	2.3	2.7	3.0	3.3	3.7	4.2	4.7	5.2	6.0	6.8

CONVERSION TABLE FOR UNITS OF LENGTH

	ANGSTROMS	MICRONS	MILS	INCHES	FEET	MILES	MILLIMETERS	CENTIMETERS	KILOMETERS
MULTIPLY NUMBER OF BY TO OBTAIN NUMBER OF ↓	ANGSTROMS	1	2.540×10^5	2.540×10^8	3.048×10^9	1.609×10^{13}	10^7	10^8	10^{13}
	MICRONS	10^{-4}	2.540×10	2.540×10^4	3.048×10^5	1.609×10^9	10^3	10^4	10^9
	MILS	3.937×10^{-6}	1	10^3	1.2×10^4	6.336×10^7	3.937×10	3.937×10^2	3.937×10^7
	INCHES	3.937×10^{-9}	3.937×10^{-5}	1	12	6.336×10^4	3.937×10^{-2}	3.937×10^{-1}	3.937×10^4
	FEET	3.281×10^{-10}	3.281×10^{-6}	8.333×10^{-5}	8.333×10^{-2}	1	5.280×10^3	3.281×10^{-3}	3.281×10^3
	MILES	6.214×10^{-14}	6.214×10^{-10}	1.578×10^{-8}	1.578×10^{-5}	1.894×10^{-4}	1	6.214×10^{-7}	6.214×10^{-6}
	MILLIMETERS	10^{-7}	10^{-3}	2.540×10^{-2}	2.540×10	3.048×10^2	1.609×10^6	1	10
	CENTIMETERS	10^{-8}	10^{-4}	2.540×10^{-3}	2.540×10^4	3.048×10	1.609×10^5	0.1	10^5
	KILOMETERS	10^{-13}	10^{-9}	2.540×10^{-8}	2.540×10^{-5}	3.048×10^{-4}	1.609×10^6	10^{-6}	10^{-5}

SYMBOLS AND PREFIXES

ac	alternating current
af	audio frequency
AFC	automatic frequency control
a-m	amplitude modulation
amp	ampere
ASA	American Standards Association
ASTM	American Society for Testing Materials
AVC	automatic volume control
ave	average
<i>B</i>	susceptance
BCD	binary-coded decimal
<i>C</i>	capacitance
C	Centigrade, degrees Centigrade
cm	centimeter
COD	cash on delivery
cps	cycles per second
cw	continuous wave
<i>D</i>	dissipation factor
db	decibel
dbm	decibel referred to one milliwatt
dc	direct current
<i>E</i>	voltage
EIA	Electronics Industries Association
emf	electromotive force
F	Fahrenheit, degrees Fahrenheit
<i>f</i>	farad
<i>f</i>	frequency
fm	frequency modulation
f.o.b.	free on board
<i>G</i>	conductance
<i>g</i>	gravitation constant
Gc	gigacycles per second
<i>g_m</i>	transconductance
<i>h</i>	henry
<i>h_f</i>	forward current-transfer ratio
<i>h_i</i>	short-circuit input impedance
<i>I</i>	open-circuit output admittance
<i>h_v</i>	reverse voltage-transfer ratio
<i>I</i>	current
IEC	International Electrotechnical Commission
IEEE	Institute of Electrical and Electronics Engineers
i-f	intermediate frequency
in.	inch
IRE	Institute of Radio Engineers

ISO	International Standards Organization
<i>j</i>	$\sqrt{-1}$
k	kilo (10 ³)
kg	kilogram
kva	kilovolt ampere
kw	kilowatt
<i>L</i>	inductance
lab	laboratory
lb	pound
LC	inductance-capacitance
lf	low frequency
log	logarithm
<i>m</i>	mass
m	meter; milli (10 ⁻³)
ma	milliamper
max	maximum
mbar	millibar
Mc	megacycles per second
mh	millihenry
mil	0.001 inch
min	minimum; minute
mm	millimeter
mmho	millimho
mΩ	milliohm
MΩ	megohm
MMΩ	megamegohm
mv	millivolt
mw	milliwatt
n	nano (10 ⁻⁹); any number
nsec	nanosecond
nū	nanomho
oz	ounce
<i>p</i>	parallel, as <i>L_p</i>
PF	power factor
pf	picofarad
PH	hydrogen in concentration
pp	push-pull; pages
ppm	parts per million
p-to-p	peak-to-peak
prf	pulse repetition frequency
<i>Q</i>	quality factor
<i>R</i>	resistance
®	registered trademark
RC	resistance-capacitance referred to
<i>re</i>	referred to
rf	radio frequency
RH	relative humidity
rms	root-mean-square
rpm	revolutions per minute
<i>s</i>	series, as <i>L_s</i>
sec	second
sync	synchronous, synchronizing
<i>T</i>	period
<i>t</i>	temperature
<i>t</i>	time

uhf	ultra-high frequency
<i>v</i>	velocity
v	volt
va	voltampere
vhf	very high frequency
vlf	very low frequency
vol	volume
vs	versus
w	watt
<i>X</i>	reactance
<i>Y</i>	admittance
<i>Z</i>	impedance
<i>α</i>	short-circuit forward current-transfer ratio (common base)
<i>β</i>	short-circuit forward current-transfer ratio (common emitter)
<i>L</i>	reflection coefficient
Δ	increment
δ	loss angle
θ	phase angle
λ	wavelength
μ	micro- (10 ⁻⁶)
μa	microampere
μbar	microbar
μf	microfarad
μh	microhenry
μsec	microsecond
μv	microvolt
Ω	ohm
ū	mho
<i>w</i>	angular velocity (2π <i>f</i>)

PREFIXES

Orders of magnitude from 10¹² to 10⁻¹⁸ are designated by the following prefixes:

Order	Prefix	Symbol
10 ¹²	tera	T
10 ⁹	giga	G
10 ⁶	mega	M
10 ³	kilo	k
10 ²	hecto	h
10	deka	da
10 ⁻¹	deci	d
10 ⁻²	centi	c
10 ⁻³	milli	m
10 ⁻⁶	micro	μ
10 ⁻⁹	nano	n
10 ⁻¹²	pico	p
10 ⁻¹⁵	femto	f
10 ⁻¹⁸	atto	a

FREQUENCY DESIGNATION OF FM BROADCAST CHANNELS

Freq. (Mc):	Channel No.	Freq. (Mc):	Channel No.	Freq. (Mc):	Channel No.
88.1	201	94.9	235	101.5	268
88.3	202	95.1	236	101.7	269
88.5	203	95.3	237	101.9	270
88.7	204	95.5	238	102.1	271
88.9	205	95.7	239	102.3	272
89.1	206	95.9	240	102.5	273
89.3	207	96.1	241	102.7	274
89.5	208	96.3	242	102.9	275
89.7	209	96.5	243	103.1	276
89.9	210	96.7	244	103.3	277
90.1	211	96.9	245	103.5	278
90.3	212	97.1	246	103.7	279
90.5	213	97.3	247	103.9	280
90.7	214	97.5	248	104.1	281
90.9	215	97.7	249	104.3	282
91.1	216	97.9	250	104.5	283
91.3	217	98.1	251	104.7	284
91.5	218	98.3	252	104.9	285
91.7	219	98.5	253	105.1	286
91.9	220	98.7	254	105.3	287
92.1	221	98.9	255	105.5	288
92.3	222	99.1	256	105.7	289
92.5	223	99.3	257	105.9	290
92.7	224	99.5	258	106.1	291
92.9	225	99.7	259	106.3	292
93.1	226	99.9	260	106.5	293
93.3	227	100.1	261	106.7	294
93.5	228	100.3	262	106.9	295
93.7	229	100.5	263	107.1	296
93.9	230	100.7	264	107.3	297
94.1	231	100.9	265	107.5	298
94.3	232	101.1	266	107.7	299
94.5	233	101.3	267	107.9	300
94.7	234				

CHANNELS AVAILABLE FOR ASSIGNMENT TO NONCOMMERCIAL EDUCATIONAL FM STATIONS

Freq. (Mc):	Channel No.	Freq. (Mc):	Channel No.	Freq. (Mc):	Channel No.
88.1	201	89.5	208	90.9	215
88.3	202	89.7	209	91.1	216
88.5	203	89.9	210	91.3	217
88.7	204	90.1	211	91.5	218
88.9	205	90.3	212	91.7	219
89.1 ¹	206	90.5	213	91.9	220
89.3	207	90.7	214		

¹ The frequency 89.1 Mc in the New York City metropolitan area is reserved for the use of the United Nations.

CONVERT ELECTRICAL DEGREES TO FEET, OR VICE VERSA WHEN FREQUENCY AND EITHER FEET OR DEGREES IS KNOWN

From the expression

$$\text{Feet} = \frac{\text{degrees}}{360^\circ} \times \frac{300}{f(\text{Mc})} \times 3.281 = \text{degrees} \times \frac{2.734}{f(\text{Mc})}$$

The following ratio may be set up on the slide rule using C and D scales:

$$\frac{2.734}{f(\text{Mc})} = \frac{\text{feet}}{\text{degrees}}$$

Set 2.734 on scale C over frequency in megacycles on scale D; read feet and degrees on scales C and D, respectively. In some instances it may be convenient to use the folded scales CF and DF.

METRIC CONVERSION

To convert pounds to kilograms, multiply by .4536
To convert inches to centimeters, multiply by 2.54

TELEPHONE CABLE COLOR CODE

Pair No.	Color	Mate
1	Blue	White
2	Orange	White
3	Green	White
4	Brown	White
5	Slate	White
6	Blue White	White
7	Blue Orange	White
8	Blue Green	White
9	Blue Brown	White
10	Blue Slate	White
11	Orange White	White
12	Orange Green	White
13	Orange Brown	White
14	Orange Slate	White
15	Green White	White
16	Green Brown	White
17	Green Slate	White
18	Brown White	White
19	Brown Slate	White
20	Slate White	White
21	Blue	Red
22	Orange	Red
23	Green	Red
24	Brown	Red
25	Slate	Red
26	Blue White	Red
27	Blue Orange	Red
28	Blue Green	Red
29	Blue Brown	Red
30	Blue Slate	Red
31	Orange White	Red
32	Orange Green	Red
33	Orange Brown	Red
34	Orange Slate	Red
35	Green White	Red
36	Green Brown	Red
37	Green Slate	Red
38	Brown White	Red
39	Brown Slate	Red
40	Slate White	Red
41	Blue	Black
42	Orange	Black
43	Green	Black
44	Brown	Black
45	Slate	Black
46	Blue White	Black
47	Blue Orange	Black
48	Blue Green	Black
49	Blue Brown	Black
50	Blue Slate	Black

NOTE—The last pair in all cables is a Red with White mate, viz.

6-pair cable	6th pair	Red	White
11-pair cable	11th pair	Red	White
16-pair cable	16th pair	Red	White
26-pair cable	26th pair	Red	White
51-pair cable	51st pair	Red	White

FORWARD VS. REFLECTED POWER

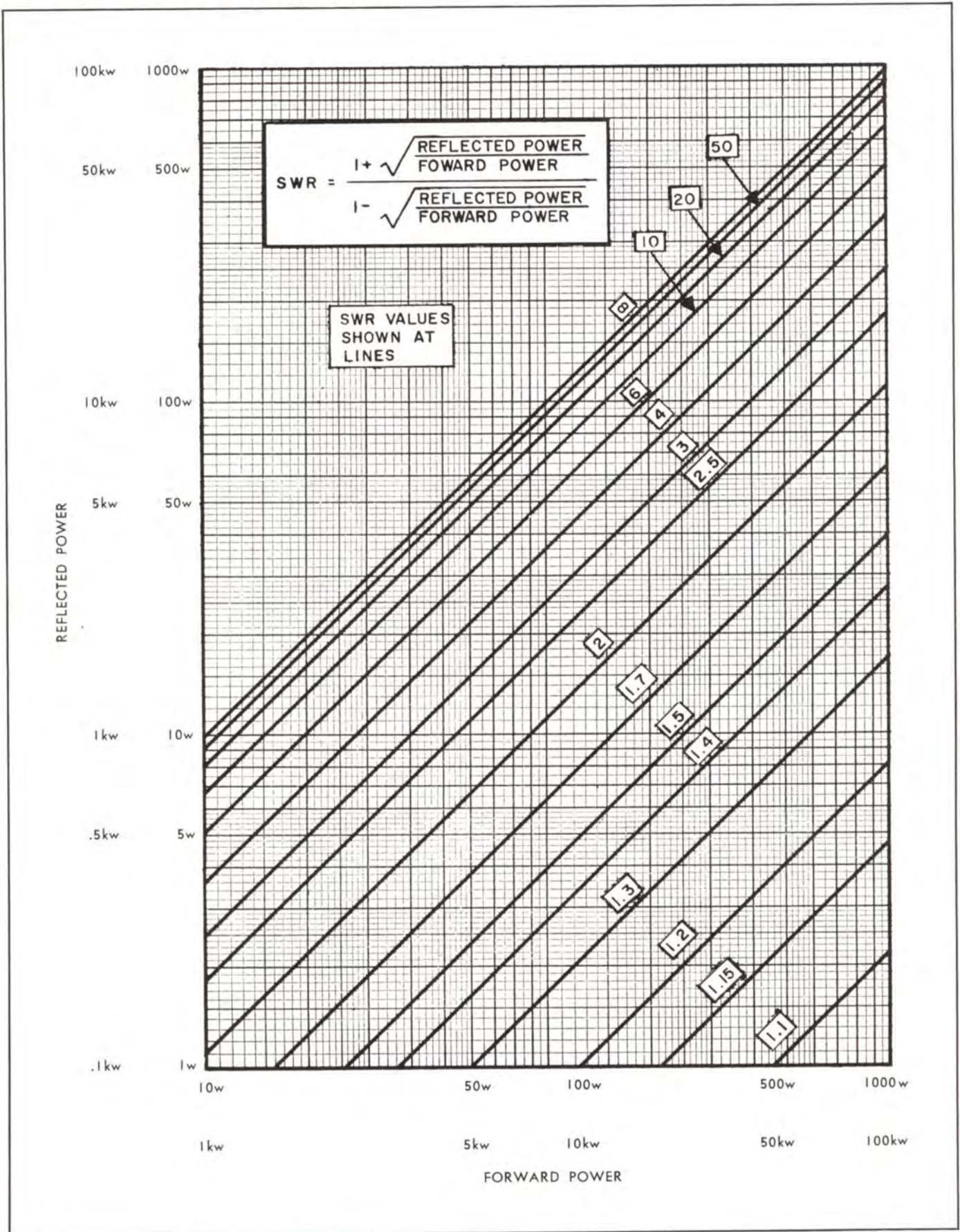

ATTENUATOR NETWORK

Input and Output $Z_0 = 600$ ohms

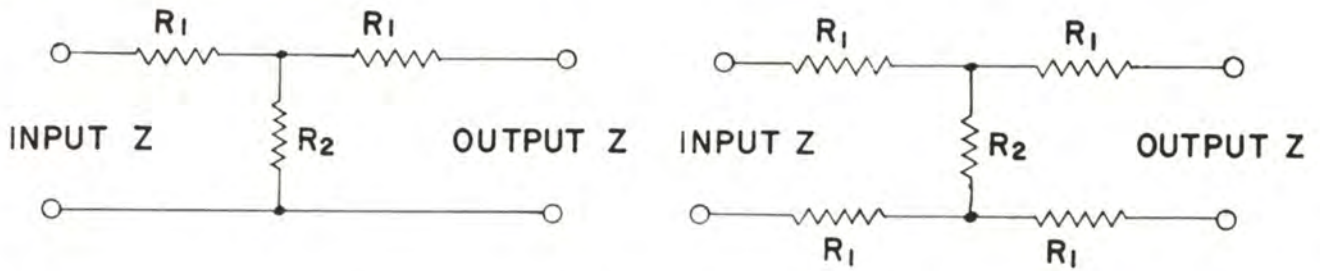

DB LOSS	R_1	R_2	DB LOSS	R_1	R_2	DB LOSS	R_1	R_2	DB LOSS	R_1	R_2
0.5	17.2	10464	16	435.8	195.1	0.5	8.6	10464	16	217.9	195.1
1	34.5	5208	17	451.5	172.9	1	17.25	5208	17	225.7	172.9
2	68.8	2582	18	465.8	152.5	2	34.4	2582	18	232.9	152.5
3	102.7	1703	19	479.0	136.4	3	51.3	1703	19	239.5	136.4
4	135.8	1249	20	490.4	121.2	4	67.9	1249	20	245.2	121.2
5	168.1	987.6	22	511.7	95.9	5	84.1	987.6	22	255.9	95.9
6	199.3	803.4	24	528.8	76.0	6	99.7	803.4	24	264.4	76.0
7	229.7	685.2	26	542.7	60.3	7	114.8	685.2	26	271.4	60.3
8	258.4	567.6	28	541.1	47.8	8	129.2	567.6	28	277.0	47.8
9	285.8	487.2	30	563.0	38.0	9	142.9	487.2	30	281.6	38.0
10	312.0	421.6	32	570.6	30.2	10	156.0	421.6	32	285.3	30.2
11	336.1	367.4	34	576.5	24.0	11	168.1	367.4	34	288.3	24.0
12	359.1	321.7	36	581.1	19.0	12	179.5	321.7	36	290.6	19.0
13	380.5	282.8	38	585.1	15.1	13	190.3	282.8	38	292.5	15.1
14	400.4	249.4	40	588.1	12.0	14	200.2	249.4	40	294.1	12.0
15	418.8	220.4				15	209.4	220.4			

ESTIMATED GROUND CONDUCTIVITY

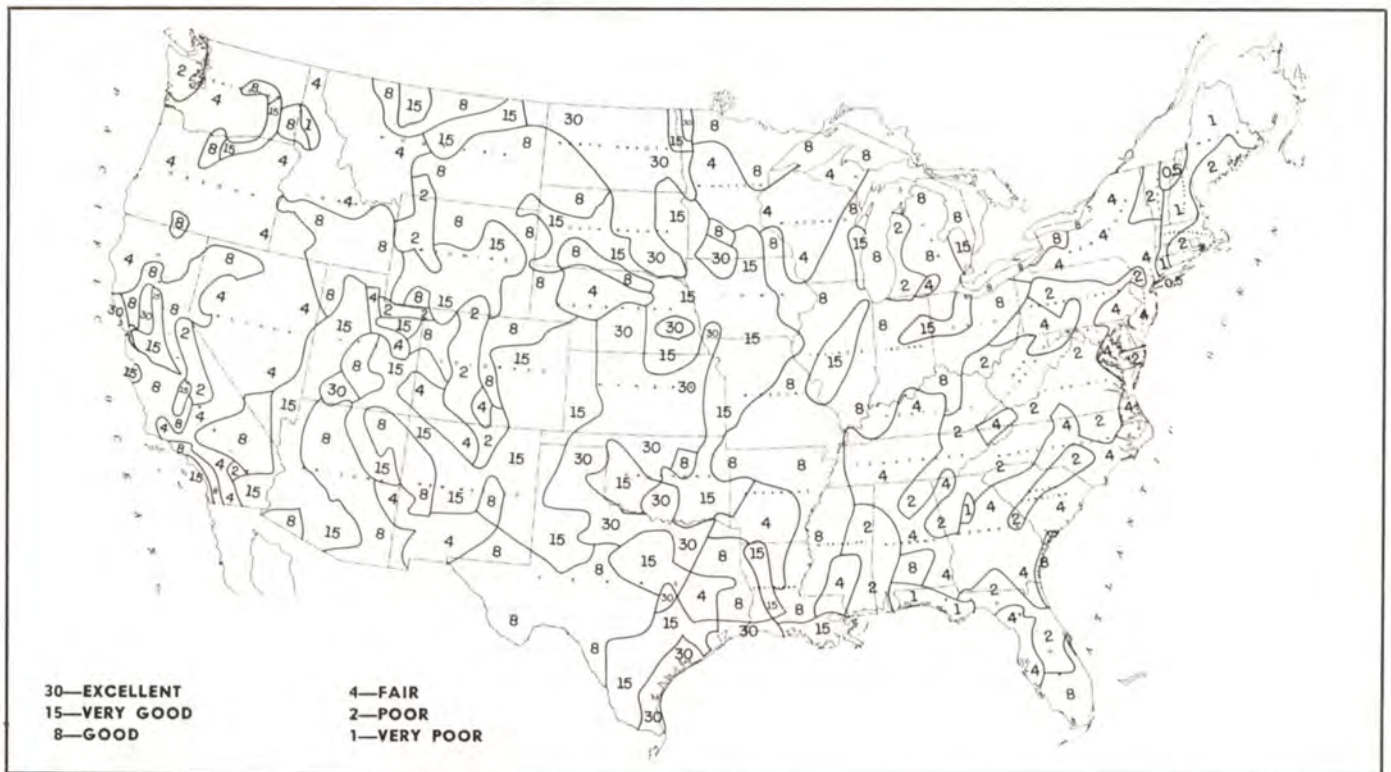

REACTANCE CHART

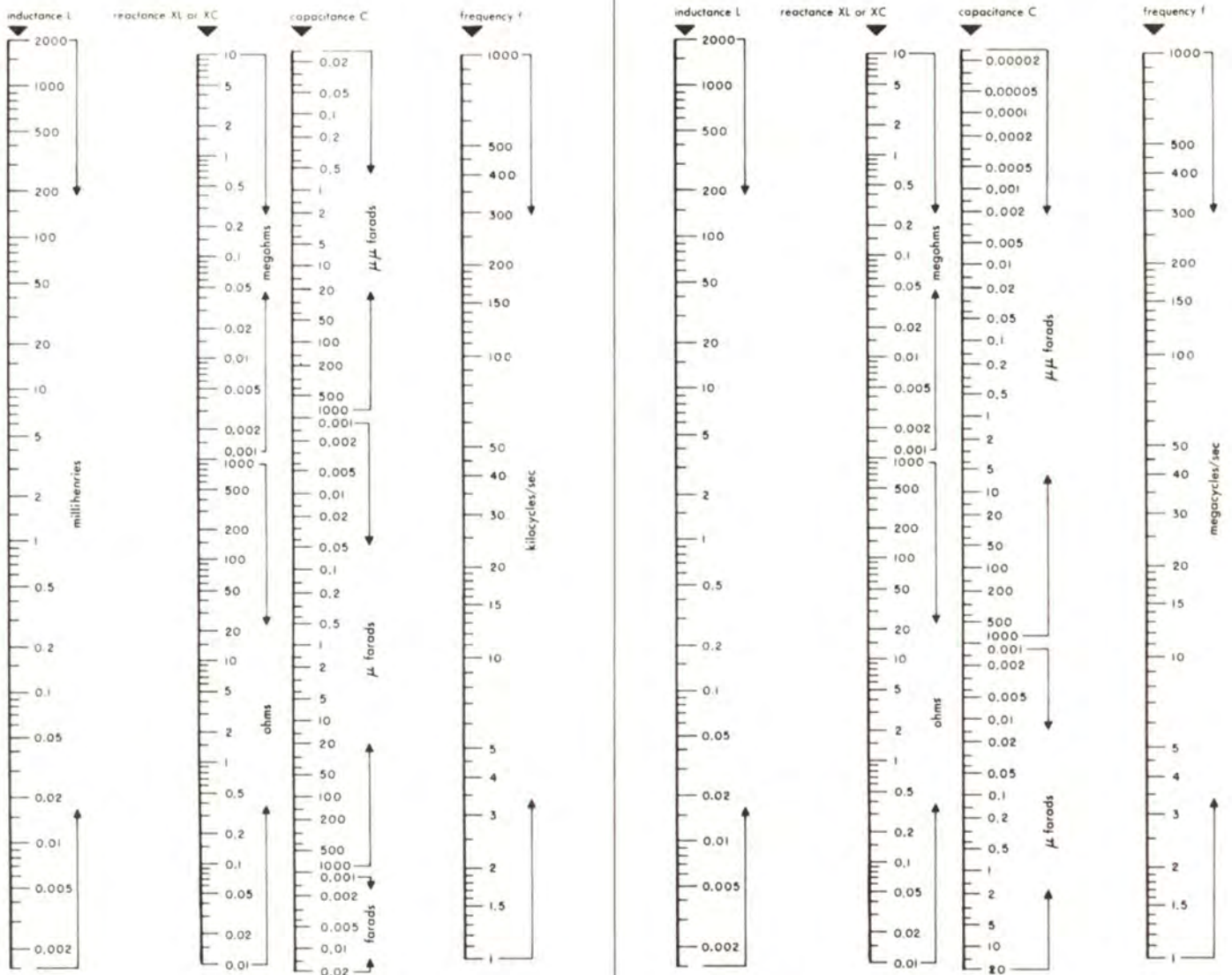

DECIMAL EQUIVALENTS OF FRACTIONS

1/32	.03125	9/32	.28125	17/32	.53125	25/32	.78125
1/16	.0625	5/16	.3125	9/16	.5625	13/16	.8125
3/32	.09375	11/32	.34375	19/32	.59375	27/32	.84375
1/8	.125	3/8	.375	5/8	.625	7/8	.875
5/32	.15625	13/32	.40625	21/32	.65625	29/32	.90625
3/16	.1875	7/16	.4375	11/16	.6875	15/16	.9375
7/32	.21875	15/32	.46875	23/32	.71875	31/32	.96875
1/4	.25	1/2	.5	3/4	.75	1	1.0

ATTENUATION EXPRESSED AS EFFICIENCY

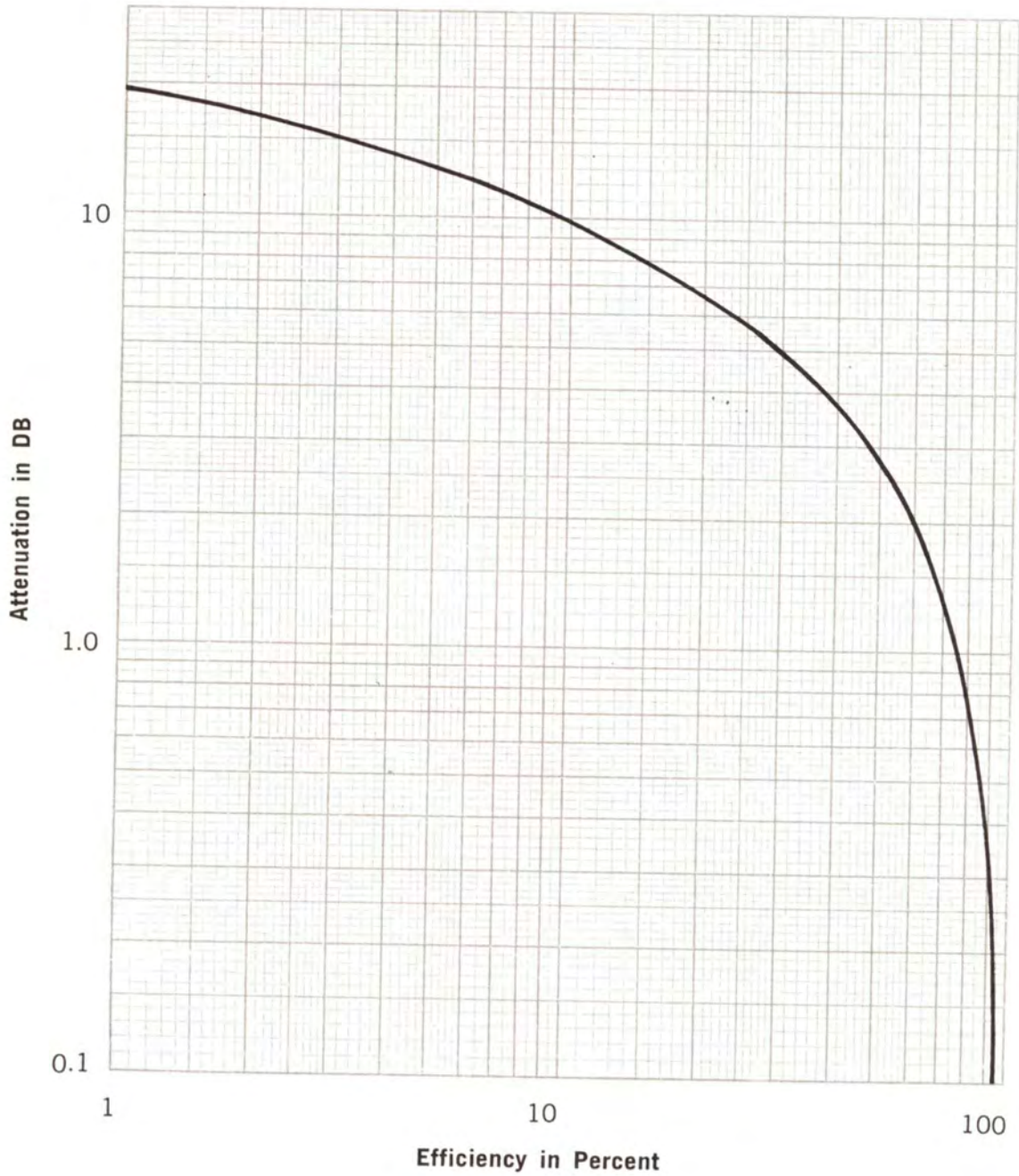

DETERMINATION OF OVERALL TRANSMISSION LINE EFFICIENCY

To obtain total loss in a given transmission line, multiply the attenuation in db per 100 ft. by the number of 100 foot lengths of line to be used. By referring to the curve on this page, the overall transmission efficiency may be determined.

STATION LAYOUTS

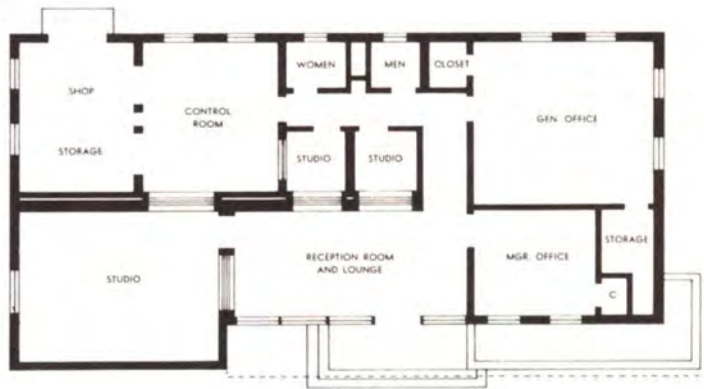
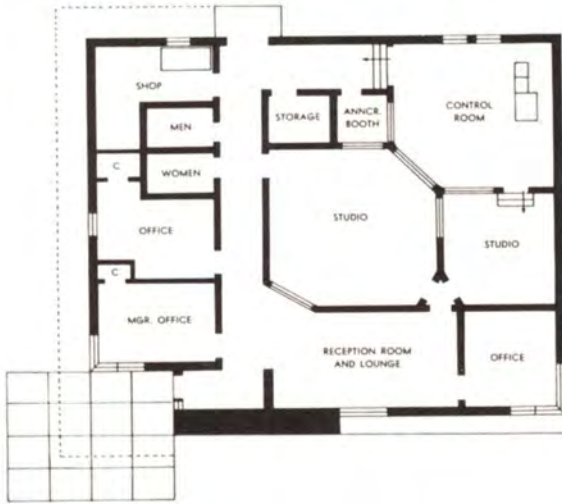

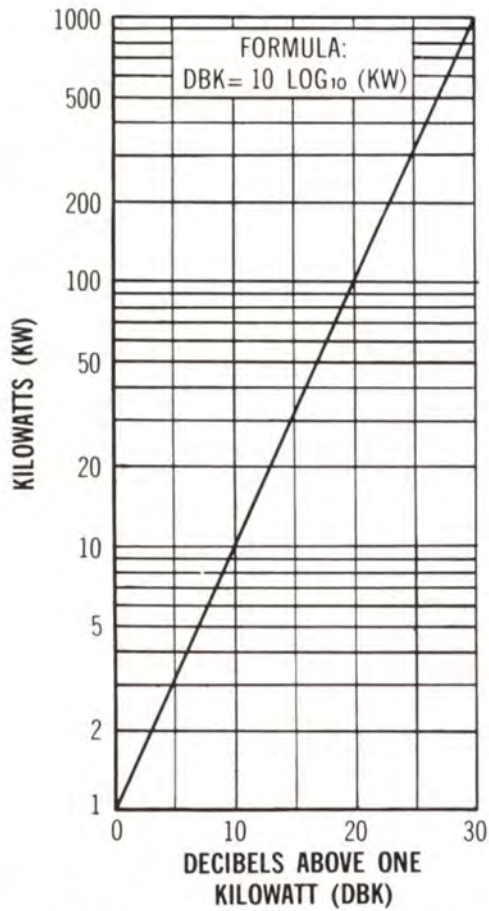

Transformation of kilowatts to decibels above 1 kw.

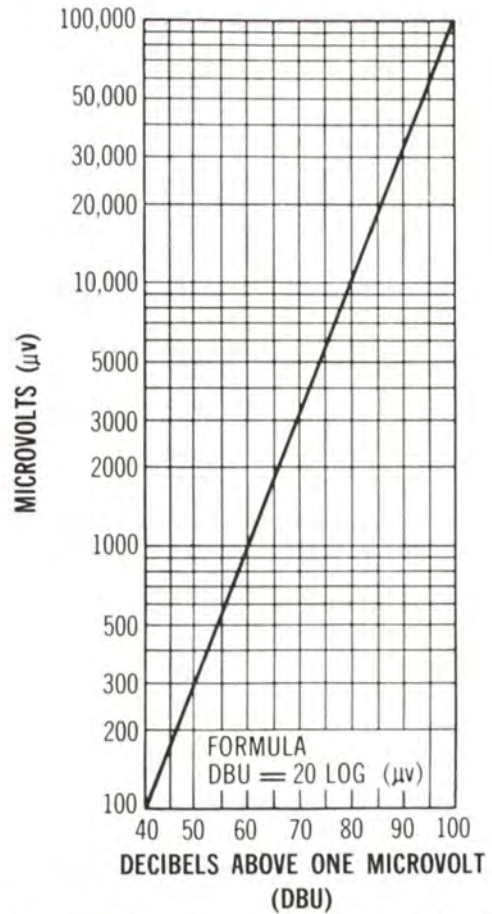

Transformation of microvolts to decibels above 1 μv .

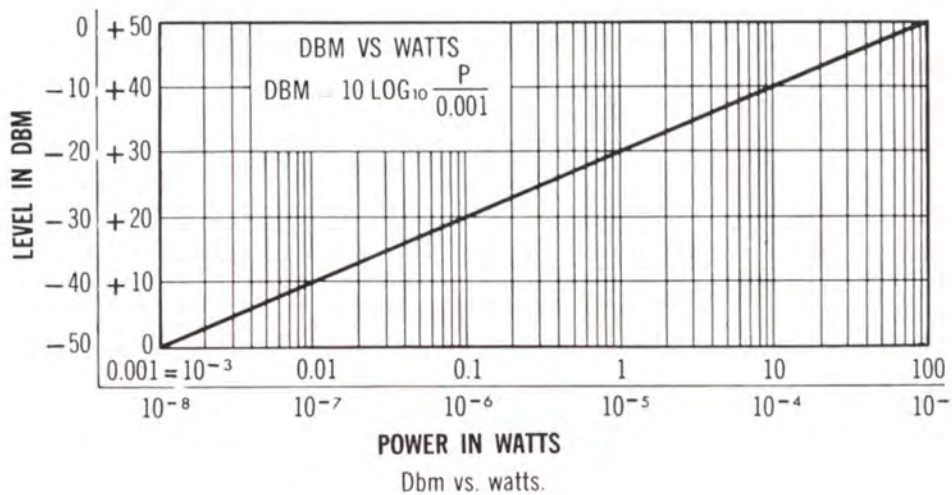

Dbm vs. watts.

Volume Level to Power and Voltage Conversion		
Reference Level 0 dbm = 1 mw, 600 ohms		
Milliwatts	Volts	Dbm
0.000001	0.0007746	- 60
0.000010	0.002449	- 50
0.000100	0.007746	- 40
0.001	0.02449	- 30
0.010	0.07746	- 20
0.100	0.2449	- 10
1.000	0.7746	0
Watts	Volts	Dbm
0.001000	0.7746	0
0.002512	1.228	+ 4
0.006310	1.946	+ 8
0.01000	2.449	+ 10
0.1000	7.746	+ 20
1.000	24.49	+ 30
10.00	77.46	+ 40

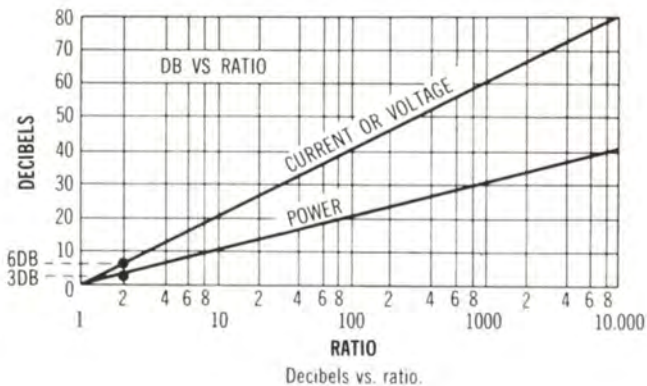

Antennas, Towers, and Wave Propagation

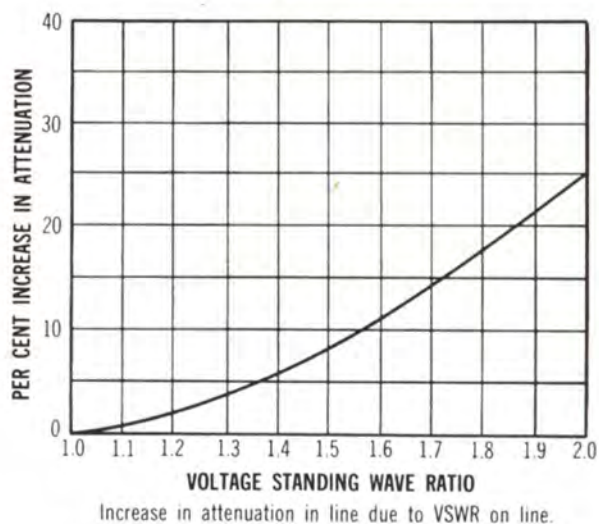

STANDARD COLOR CODE—MOLDED MICA TYPE CAPACITORS

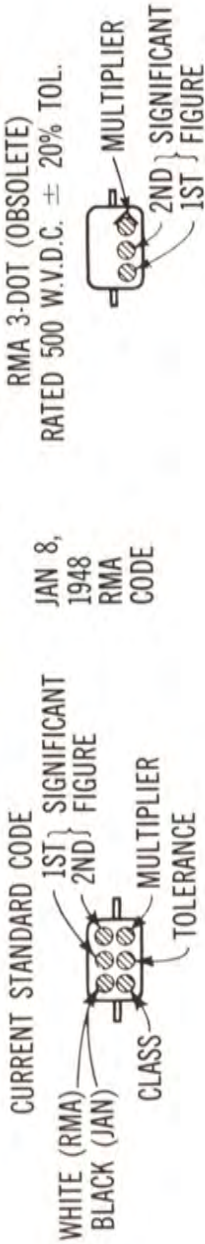

JAN 8,
 1948
 RMA
 CODE

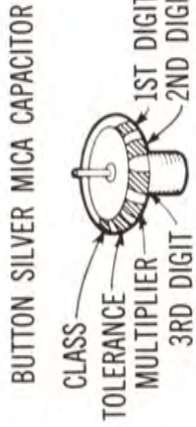

RMA (5-DOT OBSOLETE CODE)

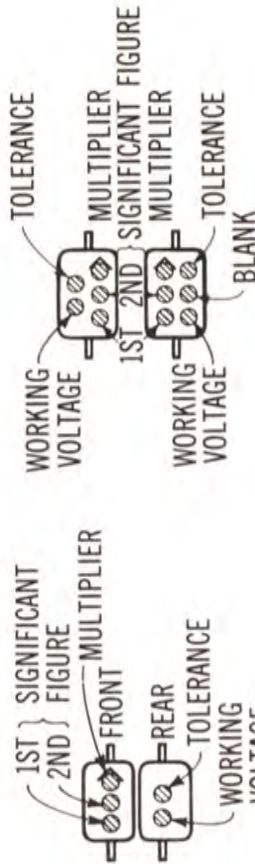

RMA 4-DOT (OBSOLETE)

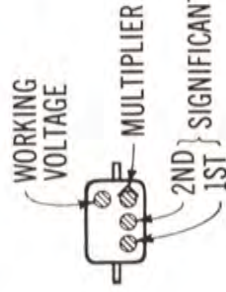

RMA 6-DOT (OBSOLETE)

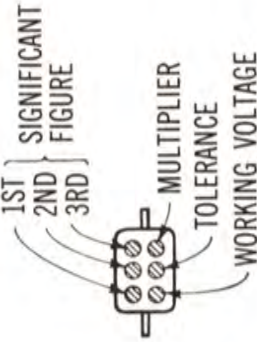

STANDARD COLOR CODE—MOLDED PAPER TYPE CAPACITORS

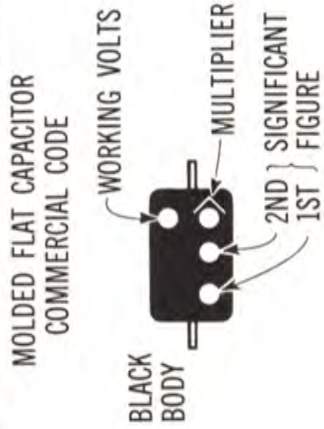

JAN. CODE CAPACITOR

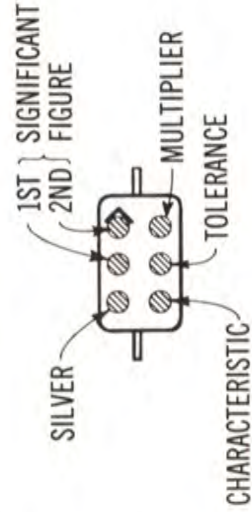

TUBULAR CAPACITOR

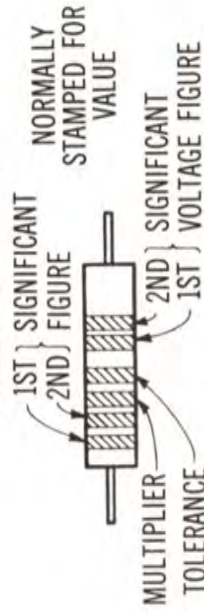

A 2 DIGIT VOLTAGE RATING INDICATES MORE THAN 900 V.
 ADD 2 ZEROS TO END OF 2 DIGIT NUMBER.

STANDARD COLOR CODE—RESISTORS AND CAPACITORS

INSULATED UNINSULATED COLOR	FIRST RING BODY COLOR FIRST FIGURE	SECOND RING END COLOR SECOND FIGURE	THIRD RING DOT COLOR MULTIPLIER
BLACK	0	0	NONE
BROWN	1	0	0
RED	2	00	00
ORANGE	3	,000	,000
YELLOW	4	0,000	0,000
GREEN	5	00,000	00,000
BLUE	6	,000,000	,000,000
VIOLET	7	0,000,000	0,000,000
GRAY	8	00,000,000	00,000,000
WHITE	9	000,000,000	000,000,000

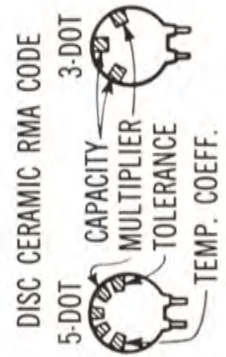
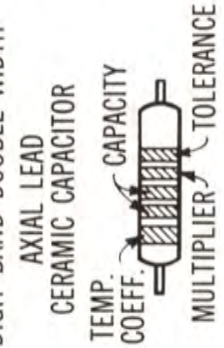
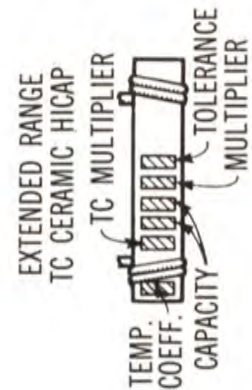
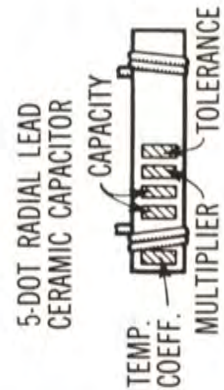
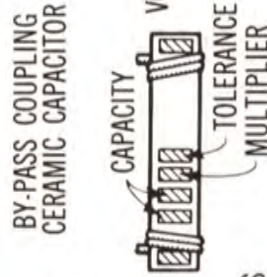
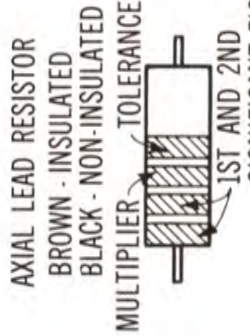

INDEX BY DESCRIPTION

Accessories, Transmission Lines	38-83	FM Towers	35	Recorder Accessories	114
Air Alert	126	FM Transmitters	21, 23, 25, 27, 29	Recorder-Amplifier	116
AM Towers	35	Foam Heliac Transmission Line	38	Recorder/Reproducer	114-116
AM Transmitters	2, 5, 8	Frequency Deviation Monitor	141	Recording Tapes	111, 112
Amplifier, Audio	95	Generator, Stereo Multiplex	18	Rectifiers	20
Amplifier, Auto-Level Limiting	98	Ground Screen	37	Relay Unit, Console	97, 98
Amplifier, Cue	97	Ground Strap	37	Remote Amplifier	130, 131
Amplifier, Limiting	96	Ground Wire	37	Remote Control	120
Amplifier, Limiting Console	100	Headphones	126	Remote Control Accessories	142
Amplifier, Program/Monitor	96	Heating Element, FM Antenna	33	Remote Control Panels	111
Amplifier, Stereo Limiting	101	Intercom, Test	142	Remote Control Recorder	117
Antenna Coupling Unit	11	Isolation Coil	15	Remote Control Tape Recorder	118
Antenna Current Metering Unit	142	Jack Panels	126	Remote Equipment	132
Antenna Current Transformer	12	Jumper Plug, Console	98	Remote Equipment Accessories	133
Assemblies, Cable Heliac	41	Latching Relay	142	Remote Turntable, Console	129
Audio Amplifier	96	Lavalier Microphone Clip	121	Replacement Pressure Pads	112
Audio Clock	120	Level Controls	125	Reproducer	115
Audio Oscillator	140	Loudspeakers	124	RF Amplifier	140
Auto-Level Limiting Amplifier	98	Meter Accessory Unit	141	Rheostat, Motorized Plate	142
Automatic Network Programmer	120	Meter, Distortion	141	Ring Transformer	37
Automatic Program Logger	120	Meter, Intensity	141	Sampling Loop	14
Automation System	119	Metering Unit, Plate Current	142	Shelf, Console	98
Baffles	125	Metering Unit, Plate Voltage	142	Short Wave Conversion	4, 7
Batteries, Remote Amplifier	131	Microphones	121, 122	Speaker	125
Beacon Light Control	37	Microphone Boom	123	Speaker/Amplifier	114
Bracket Assemblies, Console	98	Microphone Boom Stand	123	Splicing Tape	112
Cable Assemblies, Heliac	41	Microphone Cable	127	Spot Locator	120
Cable, Coaxial, Flexible Heliac	40, 41	Microphone Cord & Clip	121	Stereo Head Assembly	118
Cable, Coaxial, Spir-O-Line	48, 49	Microphone Desk Stands	121, 122	Stereo Multiplex Generator	18
Cable Fittings, Foam Heliac	38, 39	Microphone Floor Stands	123	STL Microwave Systems	143
Cable Fittings, Heliac Dielectric	45, 46	Microwave Systems, STL	143	Studio Clock	127
Cable, Heliac, Dielectric	45	Momentary Relay	142	Styli	108
Cable, Power Supply	97	Monitor, Frequency Deviation	141	Tape, Automatic Programming Test	112
Cabinet, Turntable	103	Monitor, Modulation	135, 136, 138, 139	Tape Cartridge Racks	110
Cannon Connectors	128	Oscillator, Audio	140	Tape Cartridge Repair Kit	112
Cartridges, Automatic Programming	111	Pads, Replacement Pressure	112	Tape Cartridge System	108
Cartridges & Styli	108	Pads, Turntable Indentation	103	Tape Erasers	112
Choke, Tower Lighting	11	Patch Cords	126	Tape Recorders	117, 118
Clock, Audio	120	Phase Monitor	141	Tape Recorder Case	117, 118
Clock, Studio	127	Phasing	12	Tape Splicer, Cutter	112
Conalert Speaker	125	Phasor	12	Terminal Board	127
Connectors, Cannon	128	Phono Equalizer Preamp	103	Test Cable, Console	98
Connectors, Heliac	41	Phonograph Cartridge	106, 107	Towers, AM	35
Connectors, Spir-O-Lok	55-58	Phono Reproducer	105	Towers, FM	35
Console, Desk Wing	110	Pick-up Arms	104	Tower Light Current Metering	142
Console, Production Cabinet	110	Plate Current Metering Unit	142	Tower Lighting Choke	11
Console, Speech Input	92, 93	Plate Voltage Metering Unit	142	Transformer, Loudspeaker	124
Contactors	15	Playback Arms	104, 107	Transformer, Speaker	125
Control Panels, Remote	111	Playback Head, Tape Recorder	118	Transformers, Tape Recorder	118
Conversion Kits, Tape Recorder	118	Power Supply, Console	97	Transformer, Turntable	103
Conversion Kit, Transmitter	11	Power Supply, Remote	133	Transistors	20
Crystal, Transmitter	4, 7, 20	Preamplifier	96	Transmission Lines	46, 47
Custom Control Desk	124	Primary Overload Relay	142	Transmission Line Accessories	38-83
Deicer, Antenna	33	Programmer, Automatic Network	120	Transmitter Control Unit	142
Dummy Antenna	11	Rack Cabinet Panels	127	Transmitter, Remote Control Studio Unit	142
Equalizer	103	Recorders	113, 114, 117	Tubes	4, 7, 20, 94, 96, 97, 99, 100, 141
Exciter, FM	20			Turntables	102
Flexo Mikester FM-1	123			Turntable Cabinet	103
FM Antenna	32-34			Wire, Shielded	127

INDEX BY TYPE NUMBER

1H1612 Studio Clock	127	45W Cable Fitting	39	84-875 Adapter	56
2YC Stacking Harness	133	47-150 Needle Valve	63	84-1625 Adapter	56
4G-01D Cartridge & Styli	108	48-150 Pipe Plug	63	85-500 Adapter	56
4G-02D Cartridge & Styli	108	50-150 Assembly	63	85-875 Adapter	56
4G-01S Cartridge & Styli	108	59-150 Assembly	63	85-1625 Adapter	56
4G-02S Cartridge & Styli	108	62-150 Cable Clip	64	87-500 Connector	133
4GD-01D-02D Cartridge & Styli	108	64-150 Cable Clip	64	87N Jack	42
4GD-01D-02S Cartridge & Styli	108	70-150 Gas Inlet Assembly	63	87R Flange	42
4GD-01S-02S Cartridge & Styli	108	71-500 Reducer	68	87S Connector	42
4GS-01D Cartridge & Styli	108	71-875 Reducer	58	87T Terminal	42
4GS-02D Cartridge & Styli	108	71-1625 Reducer	58	87U Jack	42
4GS-01S Cartridge & Styli	108	72-1625 Reducer	58	90-875 Cable Grip	63
4GS-02S Cartridge & Styli	108	73N Jack	42	90-1625 Cable Grip	63
19-150 Wraplock	64	73U Jack	42	91 Tape Recorder	118
20-150 Wraplock	64	75-375 Adapter	55	91-875 Anchor	64
20V3 Transmitter	2	75-500 Adapter	55	91-1625 Anchor	64
21-150 Gas Inlet Valve	63	75-875 Adapter	55	92 Tape Recorder	118
21E/M Transmitter	5	75-1625 Adapter	55	92-875 Anchor	64
22-150 Tee	63	75AN Jack	42	92-1625 Anchor	64
23-150 Manifold	65	75AR Flange	42	93 Tape Recorder	118
24-150 Pressure Gauge	63	75AT Terminal	42	93-4 Tape Recorder	118
25-150 Copper Tube	65	75AU Jack	42	93-500 Mounting Sleeve	63
26-150 Flare Fitting	61	76-375 Adapter	55	93-875 Mounting Sleeve	63
26U-1 Amplifier, Limiting Console	100	76-500 Adapter	55	93-1625 Mounting Sleeve	63
26U-2 Amplifier, Stereo Limiting	101	76-875 Adapter	55	94-875 Anchor	64
27-150 Flare Fitting	61	76-1625 Adapter	55	94-1625 Anchor	64
28-150 Nut	61	77-500 Adapter	55	95-375 End Seal	58
29-150 Elbow	61	77-875 Adapter	55	95-500 End Seal	58
30-150 Dehydrator	61	77-1625 Adapter	55	95-875 End Seal	58
31-150 Regulator	61	78-375 Adapter	56	95-1625 End Seal	58
32-150 Needle Valve	62	78-500 Adapter	56	96-375 Bulkhead	58
33-150 Bleeder Valve	62	78-875 Adapter	56	96-500 Bulkhead	58
34-150 Nipple	62	78-1625 Adapter	56	96-875 Bulkhead	58
35-150 Tube Cutter	62	78R Flange	42	96-1625 Bulkhead	58
36-150 Tube Cutter	62	78S Connector	42	97-375 Bulkhead	58
37M FM Antennas	33	79-375 Coupling	57	97-500 Bulkhead	58
38-150 Polyethylene Tape	62	79-500 Coupling	57	97-875 Bulkhead	58
39-150 Manifold	62	79-875 Coupling	57	97-1625 Bulkhead	58
40-150 Pipe Plug	62	79-1025 Coupling Assembly	78	100-375 Adapter	57
41-150 Nitrogen Cylinder	62	79-1035 Coupling Assembly	79	100-500 Adapter	57
42-150 Grounding Strap	62	79-1625 Coupling	57	100-815 Transmission Line	65
42E-7 Antenna Coupling Unit	11	80-375 Bulkhead	58	100-825 Transmission Line	67
42E-8A Antenna Coupling	11	80-500 Bulkhead	58	100-835 Transmission Line	71
42E-8B Antenna Coupling	11	80-875 Bulkhead	58	100-875 Adapter	57
43-150 Nitrogen Cylinder	63	80-1625 Bulkhead	58	100-925 Transmission Line	75
44-150 Regulator	61	81-875 Adapter	56	100-935 Transmission Line	76
44L Cable Fitting	39	81-1025 Adapter Assembly	79	101-375 Adapter	57
44N Cable Fitting	38	81-1035 Adapter Assembly	79	101-500 Adapter	57
44P Cable Fitting	38	81-1625 Adapter	56	101-875 Adapter	57
44T Cable Fitting	39	81M Phasor	12	101-925 Transmission Line	78
44U Cable Fitting	38	82-375 Adapter	56	101-935 Transmission Line	79
44W Cable Fitting	39	82-500 Adapter	56	102-815 Transmission Line	65
45-150 Flare Fitting	63	82-875 Adapter	56	102-825 Transmission Line	67
45L Cable Fitting	39	82-1025 Adapter Assembly	79	102-835 Transmission Line	71
45M Cable Fitting	39	82-1625 Adapter	56	102-925 Transmission Line	75
45N Cable Fitting	38	83-150 Cutting Wheel	64	102-935 Transmission Line	76
45P Cable Fitting	38	83-1J Adapter	133	103-375 Adapter	56
45R Cable Fitting	39	83-1SP Connector	133	103-500 Adapter	56
45T Cable Fitting	39	84-150 Cutting Wheel	56	103-815 Transmission Line	65
45U Cable Fitting	38	84-500 Adapter	56	103-825 Transmission Line	68

INDEX BY TYPE NUMBER (continued)

103-835 Transmission Line	71	212-825 Hanger	82	340 Tower	35
103-875 Adapter	56	212-835 Hanger	83	350 Recorders	114
103-925 Transmission Line	75, 78	212E-1S Console	92	351 Recorder/Reproducer	114
103-935 Transmission Line	77, 79	212G-1 Console	93	352 Reproducer	115
103-1625 Adapter	56	212H-1 Remote Amplifier	130	352-1 Recorder/Reproducer	115
105-815 Transmission Line	65	212TN Playback Arm	104	352-2 Reproducer	115
105-825 Transmission Line	68	212Z-1 Remote Amplifier	131	354 Recorder/Reproducer	116
105-835 Transmission Line	71	213-825 Hanger	82	356A-1 Preamplifier	96
105-925 Transmission Line	75	213-835 Hanger	83	356B-1 Program/Monitor Amplifier	96
105-935 Transmission Line	77	216C-2 Tape Record	108	356E-1 Limiting Amplifier	96
106-875 Adapter	57	220 Tower	35	356Q-1 Cue Amplifier	97
107-375 Adapter	57	252/U Transmission Line	48	400-RA Transmitter Control	142
107-500 Adapter	57	253/U Transmission Line	48	409X-2 Power Supply	97
107-875 Adapter	57	254/U Transmission Line	48	410 Distortion Meter	141
108 Phase Monitors	141	255/U Transmission Line	48	418 Microphone Desk Stand	122
109-375 Bulkhead	58	256/U Transmission Line	49	419 Microphone Desk Stand	122
109-875 Bulkhead	58	257/U Transmission Line	48	420 Microphone Desk Stand	122
111A-6 Recording Tape	112	258/U Transmission Line	48	420-815 Tee Assembly	66
111A-12 Recording Tape	112	259/U Transmission Line	48	420-825 Tee Assembly	69
113-375 Adapter	56	260/U Transmission Line	48	420-835 Tee Assembly	73
113-500 Adapter	56	274K-1 Relay Unit, Console	97	423-0219-00 Microphone Cable	127
113-875 Adapter	56	274K-2 Relay Unit, Console	98	425 Microphone Floor Stand	123
120 Tower	35	300 Cartridges	111	425-0061-00 Microphone Cable	127
120-835 Breakaway Section	71	300 Transmitter Control	142	425-0151-00 Microphone Cable	127
120-E Intensity Meter	141	300-815 Flange	65	427-6 Terminal Board	127
121 Meter Accessory Unit	141	300-825 Flange	68	439-5900-00 Microphone Cable	127
122-375 Adapter	57	300-835 Flange	71	448-815 Assembly	66
122-500 Adapter	57	300-925 Flange	75	448-825 Assembly	69
122-875 Adapter	57	300-935 Flange	77	448-835 Assembly	73
124-1625 Adapter	56	300C Antenna	34	448-925 Assembly	76
130-835 Transformer	71	302-815 Insulator	66	448-935 Assembly	77
142-875 Adapter	56	302-825 Insulator	68	480 Tower	35
143-375 Nut Assembly	64	302-835 Insulator	72	485-835 Assembly	73
143-500 Nut Assembly	64	303-835 Insulator	72	485-935 Assembly	78
143-875 Nut Assembly	64	304-825 Adapter	68	485-1025 Assembly	79
143-1625 Nut Assembly	64	304-835 Adapter	72	485-1035 Assembly	80
144A-1 Isolation Coil	15	305-825 Coupling	68	490-1035 Assembly	80
145-101-13 Contactor	15	305-835 Coupling	72	493-825 Assembly	69
145-102-13 Contactor	15	305-925 Coupling	75	493-835 Assembly	73
145-201-13 Contactor	15	305-935 Coupling	77	493-925 Assembly	76
145-202-13 Contactor	15	308-375 Ring	64	493-935 Assembly	98
150-18 Recording Tape	112	308-500 Ring	64	494-815 Assembly	67
156 Headphones	126	308-815 Ring	66	494-825 Assembly	69
157 Headphones	126	308-825 Ring	68	494-835 Assembly	73
170KD Tower	35	308-835 Ring	72	494-925 Assembly	76
172G-1 Dummy Antenna	11	308-875 Ring	64	494-935 Assembly	78
172G-2 Dummy Antenna	11	308-1625 Ring	64	499G-1 Console Shelf	98
180 Tower	35	310-825 Connector	68	500-815 Gas Barrier	67
190-18 Recording Tape	112	310-835 Connector	72	500-825 Gas Barrier	69
196-875 Grounding Clamp Assembly	64	312-825 Cover Plate	69	500-835 Gas Barrier	74
196-1625 Grounding Clamp Assembly	64	312-835 Cover Plate	72	500-925 Gas Barrier	76
200C Tape Eraser	112	312-835 Cover Plate	72	500-935 Gas Barrier	78
201-825 Hanger	81	313T Remote Control Panels	111	505-815 Assembly	67
201-835 Hanger	82	315-815 Flange Hardware	66	505-825 Assembly	69
202-825 Hanger	81	315-825 Flange Hardware	69	505-835 Assembly	74
202-835 Hanger	82	315-835 Flange Hardware	72	506B Modulation Monitor	135
203-825 Hanger	81	315-925 Hardware Set	75	516-835 Assembly	74
203-835 Hanger	82	315-935 Hardware Set	77	517-835 Assembly	74
204-825 Hanger	81	322-815 Adapter Assembly	66	521-815 Adapter	67
204-835 Hanger	82	322-825 Adapter Assembly	69	521-825 Adapter	69
205-825 Anchor Plate	81	322-835 Adapter Assembly	72	521-835 Taper	74
205-835 Anchor Plate	83	323-835 Coupling Assembly	73	535-825 Adapter	69
208-825 Lateral Brace	81	324-815 Flange	66	536-815 Adapter	67
208-835 Lateral Brace	83	324-825 Flange	69	536-825 Adapter	69
208-S Playback Arm	104	324-835 Flange	73	560 Transmission Line	47
208-SG Playback Arm	104	324-925 Flange	75	561 Transmission Line	47
209-825 Roller Assembly	81	324-935 Flange	77	562A Transmission Line	47
209-835 Roller Assembly	83	325-815 Adapter Assembly	66	564A-1 Sampling Loop	14
210 Audio Oscillator	140	325-825 Adapter Assembly	69	564A-2 Sampling Loop	14
211-825 Hanger	81	325-835 Adapter Assembly	73	573 Transmission Line	47
211-835 Hanger	83	325-925 Adapter Assembly	76	600 Cartridge	111
		325-935 Adapter Assembly	77		

INDEX BY TYPE NUMBER (continued)

600MA Plate Current Metering Unit	142	700133 Tape Recorder Case	118	PT6-6A Recorder	117
602 Recorders	113	A830-2 FM Exciter	20	PT6-6AX Recorder	117
602 Recorder Accessories	114	A.3818 Speaker Transformer	125	PT6-6J Recorder	117
602C Equalizer	103	AC-100 Antenna Current Metering Unit	142	PT6-6JX Recorder	117
622 Speaker/Amplifier	114	ANP-1 Automatic Network Programmer	120	PV-10 Plate Voltage Metering Unit	142
642A-2 Tape Playback	108	APL-1 Automatic Program Logger	120	RA-2 Antenna	133
665 Microphone	122	ASP-143 Bumper Mount	133	RA-Y Antenna	133
666 Microphone	122	ASP-177 Antenna	133	RC8 Remote Control	117
726 Amplifier Batteries	131	BA-200 Headphones	126	RG17/U Cable Fitting	45
763 Amplifier Batteries	131	BA-206 Headphones	126	RMC-1 Remote Control	133
786-1 Generator	18	BB-1 Microphone Boom	123	S-260 Playback Arm	107
800 Automation System	119	BS-36 Microphone Boom Stand	123	S-320 Playback Arm	107
801-835 Taper	74	BS-36W Microphone Boom Stand	123	SA-100 Remote Control, Shafer	120
808A-1 Remote Turntable, Console	129	BX800 Tape Recorder	117	SA-100 Spot Locator, Shafer	120
810-835 Reducer	74	BX801 Tape Recorder	117	SC-155-B Antenna	133
811-825 Reducer	69	CHA 250 Transmitter	8	SCB-8D Baffle	125
830B-1 FM Transmitter	21	CS-12 Loudspeakers	124	SCB-12D Baffle	125
830D-1A FM Transmitter	23	CS-33 Microphone Floor Stand	123	ST-411 Level Control	125
830E-1A FM Transmitter	25	DS-7 Microphone Desk Stand	122	ST-466 Splicing Tape	112
830F-3054 FM Transmitter	27	FH4 Transmission Line	38	ST-760 Level Control	125
830H-1A/20 FM Transmitter	29	FH5 Transmission Line	38	TBM-2500 RF Amplifier	140
900C-1 Modulation Monitor	136	FHJ4 Transmission Line	38	TBM-3000 Modulation Monitor	138
1060 Elbow	42, 47	FHJ5 Transmission Line	38	TBM-3500 Modulation Monitor	138
1061 Elbow	42, 47	FM-1 Flexo Mikester	123	TBM-4000 Modulation Monitor	139
1062 Elbow	42, 47	GR-6355 Connector	133	TC-25 Tower Light Current Metering	142
1073 Elbow	47	H3-50 Transmission Line	40	TCFW-2 Turntable Cabinet	103
1068 Elbow	47	H5-50 Transmission Line	40	TCFW-4 Turntable Cabinet	103
1181-B Frequency Deviation Monitor	141	H7-50 Transmission Line	40, 41	TI-300 Test Intercom	142
1200 Cartridge	111	H8-50A Transmission Line	40, 41	TI2017 Ring Transformer	37
1200 MA Plate Current Metering Unit	142	HD-11M Tape Eraser	112	TI2035 Ring Transformer	37
1251 Recording Tape	112	HJ3-50 Transmission Line	40	TM-8 Audio Clock	120
1260A Gas Barrier	42, 47	HJ5-50 Transmission Line	40	TPS-1 Remote Power Supply	133
1261B Gas Barrier	43, 47	HJ7-50 Transmission Line	40	TPS-TC Mobile Assemblage	133
1262A Gas Barrier	43, 47	HJ8-50A Transmission Line	40	TS4-DLX Tape Splicer, Cutter	112
1273 Gas Barrier	47	LR-1-C Latching Relay	142	TT-200 Turntable	102
1286 Gas Barrier	47	LT-80A Amplifier	95	TT-200S Turntable	102
1860 Reducer	47	M5D/M6S Phonograph Cartridge	107	TT-250S Turntable	102
1861 Reducer	47	M-20 Microphone	121	TT-400 Turntable	102
1861 Recording Tape	112	M-25C Remote Transmitter	132	TT-400S Turntable	102
1872 Reducer	47	M44-5 Phonograph Cartridge	106	TT-450S Turntable	102
2260 Adapter	47	M44-7 Phonograph Cartridge	106	UA-3-11 Connector	128
2261 Adapter	47	M-70 Microphone	121	UA-3-12 Connector	128
2262 Adapter	47	M-90AC Recorder-Amplifier	116	UA-3-13 Connector	128
2400 MA Plate Current Metering Unit	142	M-90ACX Recorder-Amplifier	116	UA-3-14 Connector	128
3009/3012 Pick-up Arms	104	M-90A Recorder-Amplifier	116	UA-3-31 Connector	128
8412 Microphone Cable	127	M-100 Microphone	121	UA-3-32 Connector	128
8422 Microphone Cable	127	M226/M222/M22 Phono Reproducer	105	UG21D/U Cable Fitting	45
8738 Microphone Cable	127	M232 Playback Arm	107	UG23D/U Cable Fitting	46
8758 Microphone Cable	127	M236 Playback Arm	107	UG29B/U Cable Fitting	45
11662-2 Insulated Hanger	43	MA-1 Antenna	133	UG146/U Cable Fitting	45
12395-1 Wraplock	43	MM-151 Recording Tape	111	UG154/U Cable Fitting	46
15069 Connector	43	MPR-2 Motorized Plate Rheostat	142	UG167A/U Cable Fitting	46
15093 Connector	43	MPR-3 Motorized Plate Rheostat	142	UG215/U Cable Fitting	46
18275 Connector	43	MPR-4 Motorized Plate Rheostat	142	WB-8C Baffle	125
18362 Reducer	47	MR-2-C Momentary Relay	142	WB-12C Baffle	125
19256A Hoisting Kit	43	MR-30/150-170 Remote Receiver	132	WG-52 Dummy Antenna	11
22418 Hanger	43	MS-10C Microphone Floor Stand	123	XLR-3-11C Connector	128
23187 Adapter	43	MS-11C Microphone Floor Stand	123	XLR-3-11SC Connector	128
24312 Hoisting Kit	43	MS-25 Microphone Floor Stand	123	XLR-3-12C Connector	128
24622 Hanger	43	P3-13 Connector	128	XLR-3-12SC Connector	128
24810 Ground Kit	43	P3-14 Connector	128	XLR-3-13 Connector	128
24811 Ground Kit	43	P3-35 Connector	128	XLR-3-13N Connector	128
26445 Transmission Line	45	P3-35-2G Connector	128	XLR-3-14 Connector	128
26459 Transmission Line	45	P3-CG-11S Connector	128	XLR-3-14N Connector	128
26985 Hoisting Kit	43	P3-CG-12S Connector	128	XLR-3-35 Connector	128
700105 Transformer	118	P8-TS Speaker	125	XLR-3-35G Connector	128
700106 Transformer	118	P12-T Speaker	125	XLR-3-36 Connector	128
700107 Transformer	118	PA-1 Antenna	133	XLR-3-36-2G Connector	128
700108 Transformer	118	PL258 Cable Fitting	46	YC Antenna	133
700120 Remote Control, Tape Recorder	118	PL259 Cable Fitting	45	ZY-2003 Loudspeaker Transformer	124
700122 Tape Recorder Case	118	POR-1 Primary Overload Relay	142		

INDEX BY PART NUMBER

013 0020 000	37M-1	33	097 3851 000	4G-01S	108	097 6952 000	PA-1	133
013 0030 000	37M-2	33	097 3852 000	4G-02S	108	097 6953 000	MA-1	133
013 0040 000	37M-3	33	097 3853 000	4G-01D	108	097 7023 000	253/U	48, 133
013 0050 000	37M-4	33	097 3854 000	4G-02D	108	097 7078 000	257/U	48
013 0060 000	37M-5	33	097 3971 000	TT-200	102	097 7079 000	81-1625	56
013 0070 000	37M-6	33	097 4200 000	Panel	126	097 7080 000	85-1625	56
013 0080 000	37M-7	33	097 4491 000	PT6-6AX	117	097 7081 —	100-825	67
013 0090 000	37M-8	33	097 4492 000	PT6-6JX	117	097 7084 000	302-825	68
013 0099 000	Deicer	33	097 5010 000	12395-1	43	097 7085 000	500-825	69
013 0107 000	Screen	37	097 5172 000	200C	112	097 7112 000	150-18	112
015 0519 000	726	131	097 5350 000	Console	110	097 7258 000	308-825	68
015 0520 000	763	131	097 5361 000	XLR-3-36-2G	128	097 7262 000	23187	43
094 2946 000	Pad	112	097 5362 000	XLR-3-36	128	097 7283 000	562A	47
097 0436 000	1860	47	097 5363 000	XLR-3-35G	128	097 7504 000	801-835	74
097 0811 000	Strap	37	097 5364 000	XLR-3-35	128	097 7522 000	Cabinet	110
097 0984 000	BB-1	123	097 5365 000	XLR-3-14N	128	097 7523 000	Transformer	103
097 1119 000	DS-7	122	097 5366 000	XLR-3-14	128	097 7527 000	254/U	48
097 1142 000	8422	127	097 5367 000	XLR-3-13N	128	097 7528 000	82-875	56
097 1267 000	CS-33	123	097 5368 000	XLR-3-13	128	097 7529 000	81-875	56
097 1445 000	Strap	37	097 5369 000	XLR-3-12SC	128	097 7544 000	2261	47
097 1500 000	BS-36	123	097 5370 000	XLR-3-12C	128	097 7559 000	Rack	110
097 1510 000	MS-25	123	097 5371 000	XLR-3-11SC	128	097 7560 000	Rack	110
097 1511 000	MS-11C	123	097 5372 000	XLR-3-11C	128	097 7581 000	AC-100	142
097 1528 000	37M-12	33	097 5423 000	Speaker	125	097 8118 000	M232	107
097 1636 000	425	123	097 5516 000	120-E	141	097 8122 000	M236	107
097 1636 000	FM-1	123	097 5620 000	1061	42, 47	097 8123 000	Pad	103
097 1693 000	37M-10	33	097 5621 000	1062	42, 47	097 8131 000	258/U	48
097 1698 000	Beacon Light Control	37	097 5727 000	Rack	110	099 0005 000	Element	33
097 1724 000	ZY-2003	124	097 5729 000	MS-10C	123	099 0008 —	H3-50	40
097 1735 000	1H1612	127	097 5754 000	1262A	43, 47	099 0040 000	190-18	112
097 1790 000	BS-36W	123	097 5948 —	1181-B	141	099 0066 000	Kit	112
097 2058 000	TS4-DLX	112	097 6006 000	WB-8C	125	099 0078 000	M-100	121
097 2119 000	P12-T	125	097 6007 000	WB-12C	125	099 0116 000	79-875	57
097 2190 000	ST-760	125	097 6008 000	WB-8C	125	099 0124 000	24622	43
097 2207 000	ST-411	125	097 6009 000	WB-12C	125	099 0137 000	Cable	133
097 2211 000	665	122	097 6029 000	8738	127	099 0146 000	Cable	133
097 2309 000	1251	112	097 6030 000	8758	127	099 0158 000	RC8	117
097 2438 000	420	122	097 6039 000	CS-12	124	099 0164 000	208-SG	104
097 2629 000	MM-151	111	097 6076 000	Tape	112	099 0177 000	YC	133
097 2888 000	M-90ACX	116	097 6131 000	TCFW-2	103	099 0910 000	2YC	133
097 2889 000	M-90R	116	097 6225 000	TCFW-4	103	099 0203 000	1260A	42, 47
097 2992 000	1861	112	097 6282 000	427-6	127	099 0204 —	H5-50	40
097 3002 000	87R	42	097 6285 000	TT-250S	102	099 0235 —	H7-50	40, 41
097 3036 000	666	122	097 6286 000	TT-450S	102	099 0238 000	1261B	43, 47
097 3132 000	418	122	097 6627 000	Clip	121	099 0241 000	S-320	107
097 3192 000	Alert	126	097 6631 —	100-835	71	099 0242 000	S-260	107
097 3561 000	Panel	126	097 6633 000	448-835	73	099 0281 000	75AT	42
097 3736 000	TT-400	102	097 6635 000	310-835	72	099 0283 000	75AR	42
097 3737 000	TT-400S	102	097 6653 000	TPS-1	133	099 0365 000	TI 2035	37
097 3806 000	PT6-6A	117	097 6663 000	2400MA	142	099 0366 000	108	141
097 3807 000	PT6-6J	117	097 6664 000	PV-10	142	099 0367 000	108	141
097 3811 000	TT-200S	102	097 6725 000	500-835	74	099 0368 000	108	141
097 3835 000	419	122	097 6739 000	494-825	69	099 0369 000	108	141
097 3844 000	4GS-01D	108	097 6742 000	308-835	72	099 0370 000	121	141
097 3845 000	4GS-02D	108	097 6781 000	MR-2-C	142	099 0371 000	HD-11M	112
097 3846 000	4GS-01S	108	097 6880 000	ASP-143	133	099 0373 000	91	118
097 3847 000	4GS-02S	108	097 6901 000	21-150	63	099 0374 000	92	118
097 3848 000	4GD-01D-02S	108	097 6920 000	T12017	37	099 0374 000	92	118
097 3849 000	4GD-01D-02D	108	097 6944 000	300-835	71	099 0375 000	93	118
097 3850 000	4GD-01S-02S	108	097 6950 000	RA-Y	133	099 0376 000	93-4	118

INDEX BY PART NUMBER (continued)

099 0377 000	Head	118	099 1399 000	300	111	370 2081 000	UA-3-12	128
099 0378 000	Head	118	099 1500 000	300	111	370 2082 000	UA-3-11	128
099 0379 000	700105	118	099 1518 000	400-RA	142	370 2083 000	UA-3-14	128
099 0380 000	700106	118	099 1519 000	400-RA	142	370 2090 000	P3-14	128
099 0381 000	700107	118	099 1520 000	LR-1-C	142	370 2150 000	P3-35	128
099 0382 000	700108	118	099 1521 000	TC-25	142	370 2170 000	P3-35-2G	128
099 0383 000	700122	118	099 1538 000	300 MA	142	370 2180 000	P3-CG-11S	128
099 0384 000	700133	118	099 1539 000	600 MA	142	370 2190 000	P3-CG-12S	128
099 0385 000	700120	118	099 1540 000	1200 MA	142	410 0209 000	145-101-13	15
099 0386 000	212TN	104	099 1544 000	MPR-2	142	410 0210 000	145-102-13	15
099 0387 000	208-S	104	099 1545 000	MPR-3	142	410 0211 000	145-201-13	15
099 0396 000	73N	42	099 1592 000	300	111	410 0212 000	145-202-13	15
099 0397 000	73U	42	099 1598 000	300	111	421 1010 001	Wire	37
099 0400 000	75AN	42	099 1900 000	1200	111	423 0219 000	Wire	127
099 0401 000	75AU	42	099 1950 —	FH5	38	425 0061 000	425-0061-00	127
099 0404 000	1060	42,47	099 1953 000	300	111	425 0151 000	425-0151-00	127
099 0406 000	18275	43	099 1993 000	300	111	425 0250 000	8412	127
099 0408 000	19256A	43	099 1994 000	300	111	439 5900 000	439-5900-00	127
099 0409 000	24810	43	099 1995 000	300	111	502 8389 123	Panel	127
099 0410 000	11662-2	43	099 1996 000	600	111	502 8393 113	Panel	127
099 0419 000	24811	43	099 1997 000	600	111	502 8397 123	Panel	127
099 0420 000	24312	43	099 1998 000	600	111	502 8401 113	Panel	127
099 0445 000	2262	47	099 1999 000	600	111	502 8405 113	Panel	127
099 0448 —	259/U	48	099 2302 000	600	111	502 8409 123	Panel	127
099 0449 —	252/U	48	099 2308 000	TBM-3500	138	502 8413 113	Panel	127
099 0450 000	255/U	48	099 2309 000	TBM-3000	138	502 8417 113	Panel	127
099 0451 —	260/U	48	099 2311 —	H8-50A	40,41	505 9578 000	21E/M	5
099 0458 000	300-825	68	099 2312 —	HJ8-50A	40	522 0330 003	212Z-1	131
099 0459 000	310-825	68	099 2314 000	78R	42	522 0389 005	356A-1	96
099 0460 000	505-825	69	099 2316 000	26985	43	522 0390 005	356B-1	96
099 0461 000	505-835	74	099 2374 000	SCB-8D	125	522 0394 005	356E-1	96
099 0462 000	M-90AC	116	099 2375 000	SCB-8D	125	522 0391 005	274K-1	97
099-0463 000	UA-3-31	128	099 2376 000	SCB-12D	125	522 0774 000	499G-1	98
099 0464 000	UA-3-32	128	099 2377 000	SCB-12D	125	522 0966 000	26U-1	100
099 0479 000	BX801	117	099 2454 000	FH4	38	522 1028 000	42E-7	11
099 0480 000	BX800	117	099 2455 000	44U	38	522 1029 000	42E-8A	11
099 0481 000	Case	117	099 2500 —	TBM-2500	140	522 1410 014	172G-1	11
099 0482 000	Case	117	099 2517 000	44T	39	522 1411 014	172G-2	11
099 0484 000	82-500	56	099 2518 000	44W	39	522 1518 004	564A-1	14
099 0485 000	82-1625	56	099 2519 000	45T	39	522 1519 004	564A-2	14
099 0486 000	85-500	56	099 2527 000	HJ3-50	40	522 1520 000	144A-1	15
099 0487 000	85-875	56	099 2553 000	45U	38	522 1605 000	212G-1	93
099 0488 000	124-1625	56	099 2557 000	44P	38	522 1606 000	274G-2	98
099 0489 000	79-375	57	099 2625 000	FHJ5	38	522 1607 000	356Q-1	97
099 0490 000	79-500	57	099 2642 000	FHJ4	38	522 1691 000	409X-2	97
099 0491 000	79-1625	57	099 2644 000	A-3818	125	522 2419 000	212H-1	130
099 0492 000	95-375	58	099 2814 000	Amplifier	98	522 2468 000	Preamp	103
099 0493 000	95-500	58	099 3000 000	506B	135	522 2480 000	20V3	2
099 0494 000	95-875	58	099 3003 000	87N	42	522 2550 000	313T-1	111
099 0495 000	BA-206	126	099 3004 000	87U	42	522 2551 000	313T-3	111
099 0496 000	ST-466	112	099 3005 000	87T	42	522 2552 000	313T-4	111
099 0501 000	20-150	64	099 3006 000	87S	42	522 2609 000	808A-1	129
099 0517 000	30-150	61	099 5464 000	M-20	121	522 2714 000	A&30-2	20
099 0541 000	TPS-TC	133	099 5826 000	Stand	121,121	522 2871 000	830B-1	21
099 0542 000	RMC-1	133	099 6723 000	24-150	63	522 2872 000	830E-1A	25
099 0543 000	RA-2	133	099 7096 000	561	47	522 2914 000	78E-1	18
099 0544 000	SC-155-B	133	099 8123 000	95-1625	58	522 2969 000	830D-1A	23
099 0545 000	ASP-177	133	272 1407 000	111A-12	112	522 3054 000	830F-3054	27
099 0546 000	83-1SP	133	272 1408 000	111A-6	112	522 3237 000	26U-2	101
099 0547 000	83-1J	133	272 1438 000	602C	103	522 3275 000	900C-1	136
099 0548 000	GR-6355	133	273 0002 000	BA-200	126	522 3496 000	216C-2	108
099 0549 000	87-500	133	273 0003 000	156	126	522 3497 000	642A-2	108
099 0569 000	410	141	273 0004 000	157	126	522 3592 000	830H-1A/20	29
099 0824 —	TBM-4000	139	289 2743 000	Crystal	20	541 6459 002	Plug	98
099 0827 000	210	140	361 0010 000	Patch Cord	126	541 6473 003	Cable	98
099 0870 000	Clip	121	361 0011 000	Patch Cord	126	542 3024 004	409X-2	97
099 0890 —	HJ7-50	40	361 0012 000	Patch Cord	126	542 3038 002	Assembly	98
099 1188 —	HJ5-50	40	361 0013 000	Patch Cord	126	542 3039 002	Assembly	98
099 1393 000	300	111	361 0014 000	Patch Cord	126	542 3040 003	Assembly	98
099 1394 000	300	111	361 0015 000	Patch Cord	126	542 3041 004	Assembly	98
099 1395 000	300	111	361 0016 000	Patch Cord	126	543 3917 000	Transformer	12
099 1396 000	300	111	370 2060 000	P3-13	128	543 3926 000	Choke	11
099 1397 000	300	111	370 2079 000	UA-3-13	128	543 3927 000	Choke	11
						553 2652 005	212E-1S	92

***COLLINS BROADCAST
COMMUNICATION
SALES POLICY***

HOW TO ORDER

This catalog has been prepared to make it possible for you to order directly from the Collins Broadcast Communication Division or your Collins Broadcast Sales Engineer with a minimum of effort and maximum assurance that you will receive the best equipment available. Collins type numbers and part numbers are listed so that you may order by mail, if you wish, and receive the same fast, personal service that is available from your Collins Broadcast Sales Engineer.

PRICES

Prices in the price book inside the back cover replace all previous prices and are subject to change without notice. Orders are filled at prices in effect at the time of shipment. If prices are reduced, you receive the advantage of the lower price. Collins customers outside the 50 United States should contact Collins Radio Company, International Division, Dallas, Texas, or Collins Radio Company of Canada, Ltd., Toronto 16, Ontario.

SIGNED ORDERS

All orders must be signed by an officer of the purchasing corporation, partnership or company. All orders, down payment agreements and terms are subject to final acceptance at the Collins Broadcast Sales Division office in Dallas, Texas.

SUBSTITUTION AND MODIFICATION

Collins reserves the right to modify, without notice, the design and specifications of equipment designed by Collins.

TERMS OF SALE

Terms of payment for all Collins Radio Company broadcast equipment sales fall into the following categories:

1. Cash in advance or C.O.D.
2. Net 30 days.
3. 30-60-90 days (no interest or carrying charge).
4. Conditional Sales Contract.

DOWN PAYMENT

On all firm orders applicable to Conditional Sales Contracts, a minimum down payment of 25% is required, with the balance spread equally. In the case of contingent orders, a minimum of 3% down is required.

SHIPMENT

In the absence of specific instructions Collins will select the carrier to whom delivery will be made for shipment to the purchaser.

DAMAGES IN SHIPPING

Usually, shipments from Collins Radio Company or one of its vendors on a drop ship basis are made "Shipping Charges Collect." As such, the equipment automatically becomes the property of the purchaser when picked up by the carrier. Should damage occur during shipment, the request for inspection and claims for damage must be made by the purchaser with reimbursement paid directly to him. Collins will gladly assist the purchaser with any necessary information he may require to successfully negotiate a claim.

DELIVERY

Unless otherwise specified, delivery will be made f.o.b. from one of Collins' various shipping points or from the shipping point of a supplier of Collins. Although Collins makes every effort to expedite shipments, the Company cannot guarantee nor be held responsible for delays in shipments caused by a supplier of Collins or by the carrier.

FIELD SERVICE

Fast field service is assured owners of Collins broadcast equipment by the Collins Service Division. A staff of selected specialists is maintained to provide Collins customers a level of service consistent with high performance equipment. For service on Collins equipment which is essential to continued on-the-air operations of the station, contact your Collins Broadcast Sales Engineer. For emergency, after-hours service, Call Dallas, Texas, 214 AD 5-9511. Collins field service engineers are stationed at key points throughout the world. Overseas customers contact your nearest International office.

RETURNING GOODS

All returned goods, whether for repair, replacement or credit, must be authorized by Collins Radio Company. A

return material tag and service report will be enclosed with your authorization for the return of the goods. An accurately completed report will assure prompt handling of repairs, necessary parts, replacements and adjustments of accounts where required. Address material as follows:

Collins Radio Company

Dallas, Texas 75207

Attention: CRG/Re (Sales Order Number)

Contingent on Collins' agreement to accept such returned goods, a restocking charge of 15% will be made on all items returned due to customer requested changes or deletions from original orders after shipment is made. All returns must be sent prepaid and properly insured by the customer. If warranted, Collins will adjust and/or issue credit for these shipping expenses.

GUARANTEE

Collins' faith in its equipment — as well as its record of quality and reliability — allows the Company to maintain a formal guarantee that Collins will repair or replace, without charge, any equipment, parts or accessories which are defective as to design, workmanship or material, and which are returned to Collins with transportation prepaid. To be eligible for the Collins guarantee, several conditions must be met:

1. Notice of the claimed defect in equipment manufactured by Collins is given Collins within two years from date of delivery and goods are returned in accordance with Collins' instructions to you.
2. Equipment, accessories, tubes and batteries not manufactured by Collins or from a Collins design are subject to only such warranties and adjustments as Collins may obtain from the supplier.
3. Equipment or accessories will not be considered defective if the equipment has been exposed to improper treatment, excessive moisture or if it has been altered or repaired by persons other than Collins authorized representatives.

In no event does Collins have any liability for consequential damages or for the loss, damage or expense directly or indirectly arising from the use of the products or any inability to use them either separately or in combination with other equipment or materials or from any other cause. Collins further guarantees that any Collins radio transmitter will deliver full radio frequency power output at the antenna terminal when connected to a suitable load, but Collins does not guarantee any definite coverage or range.

UNITED STATES BROADCAST OFFICES

Collins Radio Company
Broadcast Communication Division
Dallas 7, Texas
Telephone: Area Code 214 ADams 5-9511

K. A. Blake
Collins Radio Company
P. O. Box 57087
Los Angeles 57, California
Telephone: DUnkirk 5-6421

California, Nevada, Oregon, Washington

B. E. Dobbins
2662 Elm Avenue
Boulder, Colorado
Telephone: 442-6163

Arizona, Colorado, Idaho, Montana, Utah, Wyoming

R. C. Evans
P. O. Box 8026
Jackson 4, Mississippi
Telephone: 939-4220

Arkansas, Western Half of Kentucky, Louisiana, Mississippi, Western Half of Tennessee

R. J. Henry
Route 2
Roanoke, Indiana
Telephone: 672-2906

Indiana, Michigan (East of Lake Michigan), Ohio

L. H. Leggett
Collins Radio Company
1271 Avenue of the Americas
New York 20, New York
Telephone: JUdson 6-5678

Connecticut, Delaware, District of Columbia, Maine, Maryland, Massachusetts, New Hampshire, New Jersey, New York, Pennsylvania, Rhode Island, Vermont

J. L. Littlejohn
12708 Myrtle Circle
Hopkins, Minnesota
Telephone: 935-7011

Michigan (West of Lake Michigan), Minnesota, Nebraska, North Dakota, South Dakota, Wisconsin

E. G. Randolph
Collins Radio Company
Cedar Rapids, Iowa
Telephone: EMpire 5-8411

Illinois, Iowa, Kansas, Missouri

J. H. Speck
Collins Radio Company
Dallas, Texas
Telephone: ADams 5-9511

New Mexico, Oklahoma, Texas

J. F. Stanbery
P. O. Box 325
Gatlinburg, Tennessee
Telephone: 436-5497

Eastern Half of Kentucky, North Carolina, South Carolina, Eastern Half of Tennessee, Virginia, West Virginia

C. W. Walters
3658 Colebrook Drive
Jacksonville, Florida
Telephone: SPring 1-2978

Alabama, Florida, Georgia

Special Consultant
George Wetmore
Collins Radio Company
Universal Building
Washington, D.C.

INTERNATIONAL

Collins Radio Company
International Division
Dallas 7, Texas, U.S.A.



Why is this trademark important to you?

For 30 years one principle has guided us in meeting our responsibility to provide you with equipment of the highest performance standards. That principle is *integrity*.

<i>integrity in design</i>	25% of our people are in Research and Development.
<i>integrity in manufacturing</i>	The best facilities, the best materials, the industry's finest craftsmen.
<i>integrity in sales</i>	Honest claims, backed up by a seldom-used but always dependable guarantee.
<i>integrity in service</i>	Around the world, around the clock to <i>insure</i> Collins performance.

Our trademark is a symbol of Collins integrity. You can depend on it.



COLLINS RADIO COMPANY • Broadcast Communication Division, Dallas • International Division, Dallas

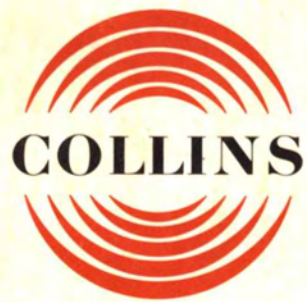

If You Didn't Get This From My Site,
Then It Was Stolen From...

www.SteamPoweredRadio.Com